

Halsey Taylor Owners Manual

HRFSBP - FR HRFEBP - FR HRFSEBP - FR HRFESBP - FR
 Freeze Resistant Fountains

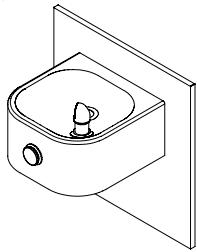

HRFSBP - FR

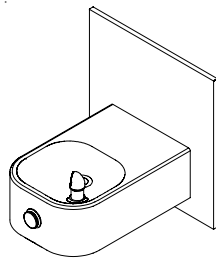

HRFEBP - FR

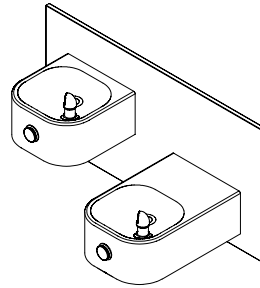

HRFSEBP - FR

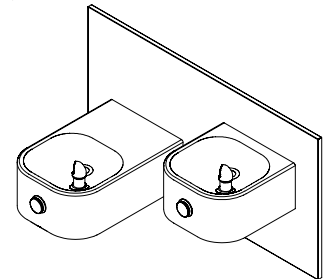

HRFESBP - FR

Installer

To assure you install this model easily and correctly, PLEASE READ THESE SIMPLE INSTRUCTIONS BEFORE STARTING THE INSTALLATION. CHECK YOUR INSTALLATION FOR COMPLIANCE WITH PLUMBING, ELECTRICAL AND OTHER APPLICABLE CODES. After installation, leave these instructions inside the fountain for future reference. This Freeze Resistant Fountain is shipped in two separate cartons. The second carton(s) contains the Freeze Resistant Package(s) **HTFRB1** that are installed on an interior heated wall. The interior space must maintain a minimum temperature of 50° F (10° C). Refer to the Freeze Resistant Package for the rough-in dimensions for installation.

IMPORTANT

ALL SERVICE TO BE PERFORMED BY AN AUTHORIZED SERVICE PERSON

IMPORTANT! INSTALLER PLEASE NOTE.

THE GROUNDING OF ELECTRICAL EQUIPMENT SUCH AS TELEPHONE, COMPUTERS, ETC. TO WATER LINES IS A COMMON PROCEDURE. THIS GROUNDING MAY BE IN THE BUILDING OR MAY OCCUR AWAY FROM THE BUILDING. THIS GROUNDING CAN CAUSE ELECTRICAL FEEDBACK INTO A FOUNTAIN, CREATING AN ELECTROLYSIS WHICH CAUSES A METALLIC TASTE OR AN INCREASE IN THE METAL CONTENT OF THE WATER. THIS CONDITION IS AVOIDABLE BY USING THE PROPER MATERIALS AS INDICATED. ANY DRAIN FITTINGS PROVIDED BY THE INSTALLER SHOULD BE MADE OF PLASTIC TO ELECTRICALLY ISOLATE THE FOUNTAIN FROM THE BUILDING PLUMBING SYSTEM.

The freeze resistant package must be mounted on an interior wall in a heated area. The room temperature of the interior heated area must be 50° F (10° C) or higher. The freeze resistant package may be surface or recessed mounted. If recess mounted the surface of the cover must be flush with the interior wall surface. The package is furnished with screws for mounting the cover to the box. If the box is recess mounted, do not fasten the top and bottom of the cover to the box. Use the holes on the front only.

1. Fountains using the MPW Mounting Plate refer to Fig's. 7, 11, or 15 for hanger bracket location and rough-in dimensions.
NOTE: Review separate installation instructions for details of the MPW Mounting Plate.
Fountains using the Wall Plate Assy. refer to Fig's. 3, 5, 9, or 13 for rough-in dimensions.
2. Shown dimensions pertain to installation location (framing must support up to 150 lbs. weight for single fountain and 300 lbs. for dual fountains). These dimensions are required for compliance with ANSI Standard A117.0.
3. Installing back panel.
Ftn. w/MPW Mounting Plate: Refer to Fig. 24 for placement of braces onto back panel. Place the upper edge of the panel above hanger bracket. Slide the panel down until it engages the hanger bracket. Be sure back panel is firmly engaged before releasing it.
Ftn. w/Wall Plate Assy.: Place the upper edge of the panel above mounting plate on the wall. Slide the panel down until it engages the hanger. Be sure back panel is firmly engaged before releasing it.
4. Remove bottom access panel from fountain basin and save the screws.
Ftn. w/Back Panel: Install fountain to back panel and wall using (4) 5/16" x 2.00" long lag bolts and washers (NOT PROVIDED).
Ftn. w/MPW Mounting Plate: Install the fountain to the back panel and wall using (4) 5/16" x 6" long threaded rods, washers, and nuts (provided). Tighten securely.
Ftn. w/Wall Plate Assy.: Install the fountain to the back panel and wall using (4) 5/16" x 3/4" long bolts and washers (provided) thru holes in back panel. A washer is used on the bottom two (2) holes only. Tighten securely.
5. Assemble the operating cable to the fountain bracket. (Fountain should be mounted to exterior wall) Create a loop in the cable and thread the free end of the cable through the wall into the freeze resistant box. The adjustment nuts should be in the middle of threaded area on the operating cable. See Figure 18.
6. Connect free end of operating cable to the valve-operating bracket. The end of the cables must be recessed into the indents on the pivot brackets. Remove cable free play by adjusting the jam nuts on the ends of the operating cable. See Figure 18.
7. Connect water line from fountain bubbler into freeze resistant box. The connection to the box uses a quick connect water fitting. Position the water line, in the fountain, to drain back into interior mounted box. Any water left standing, in the exterior line, can freeze . See Fig. 21.

To insert tubing, push tube straight into fitting until it reaches a positive stop. To remove tubing from the fittings, relieve water pressure, push in on dark gray collar while pulling out on the tubing. See Figure 2.
8. Connect drain and water supply lines to the freeze resistant fountain. Refer to Figure's 3 thru 16 for component positions.
Inline strainer must be used on the inlet water line. See Fig. 1.

Start-up

1. Turn on building water supply and check all connections for leaks. Repair as required.
2. Stream height is factory set at 35 PSI. If stream height needs to be changed adjust the regulator in the freeze resistant package. Clockwise adjustment raises stream height, counter clockwise adjustment will lower stream.
3. Adjust operating cable as required. Cable system should have a minimal amount of free play to allow for proper valve operation. If the system is too tight the valve will stay in the on position creating constant water flow. Too much free play will result in non-operation of the valve with the push-buttons.
4. Note: Water from the drain back tube in the freeze resistant package, will continue to run while the valve is actuated.
5. After cable system is adjusted properly stuff flexible insulation into any openings between the outside wall and the interior box.
6. Recheck all connections. If all connections are leak free replace cover(s) on the freeze resistant box(es) and fountain(s).

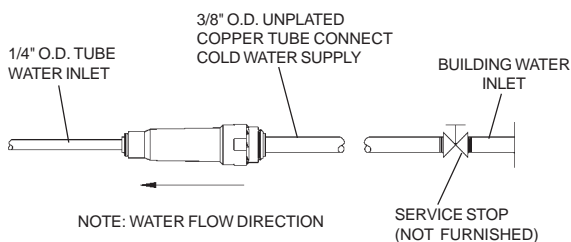

FIG. 1

OPERATION OF QUICK CONNECT FITTINGS

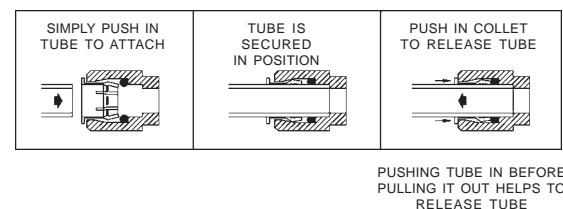
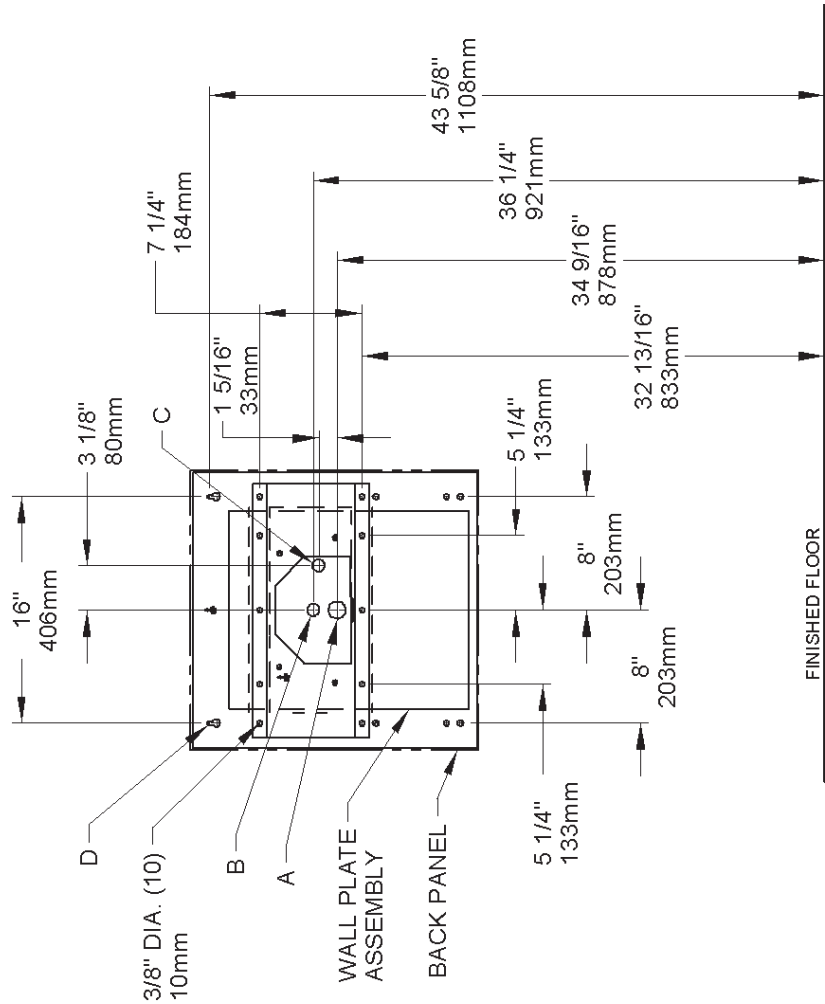
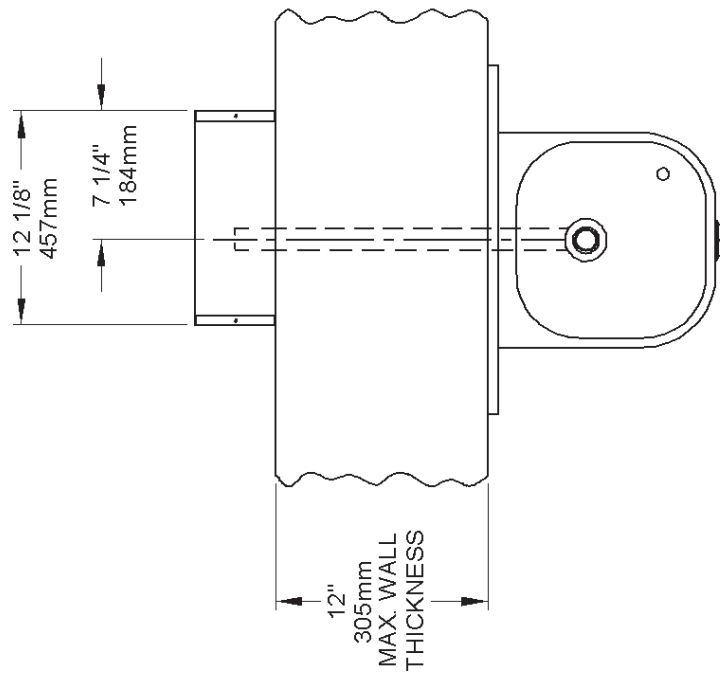

FIG. 2

**HRFSBP - FR WITH WALL PLATE ASSY.
MOUNTING BOLT AND ACCESS HOLE LAYOUT**

FIG. 3



- LEGEND**
- A = 1-3/4" DIA. (44mm) HOLE FOR WASTE LINE
 - B = 7/8" DIA. (22mm) HOLE FOR WATER SUPPLY TUBE
 - C = 7/8" DIA. (22mm) HOLE FOR OPERATING CABLE
 - D = 1/4" DIA. (6mm) HOLES FOR MOUNTING PLATE TO WALL

**HRFSBP - FR WITH WALL PLATE ASSY.
ROUGH-IN DRAWINGS**

FIG. 4

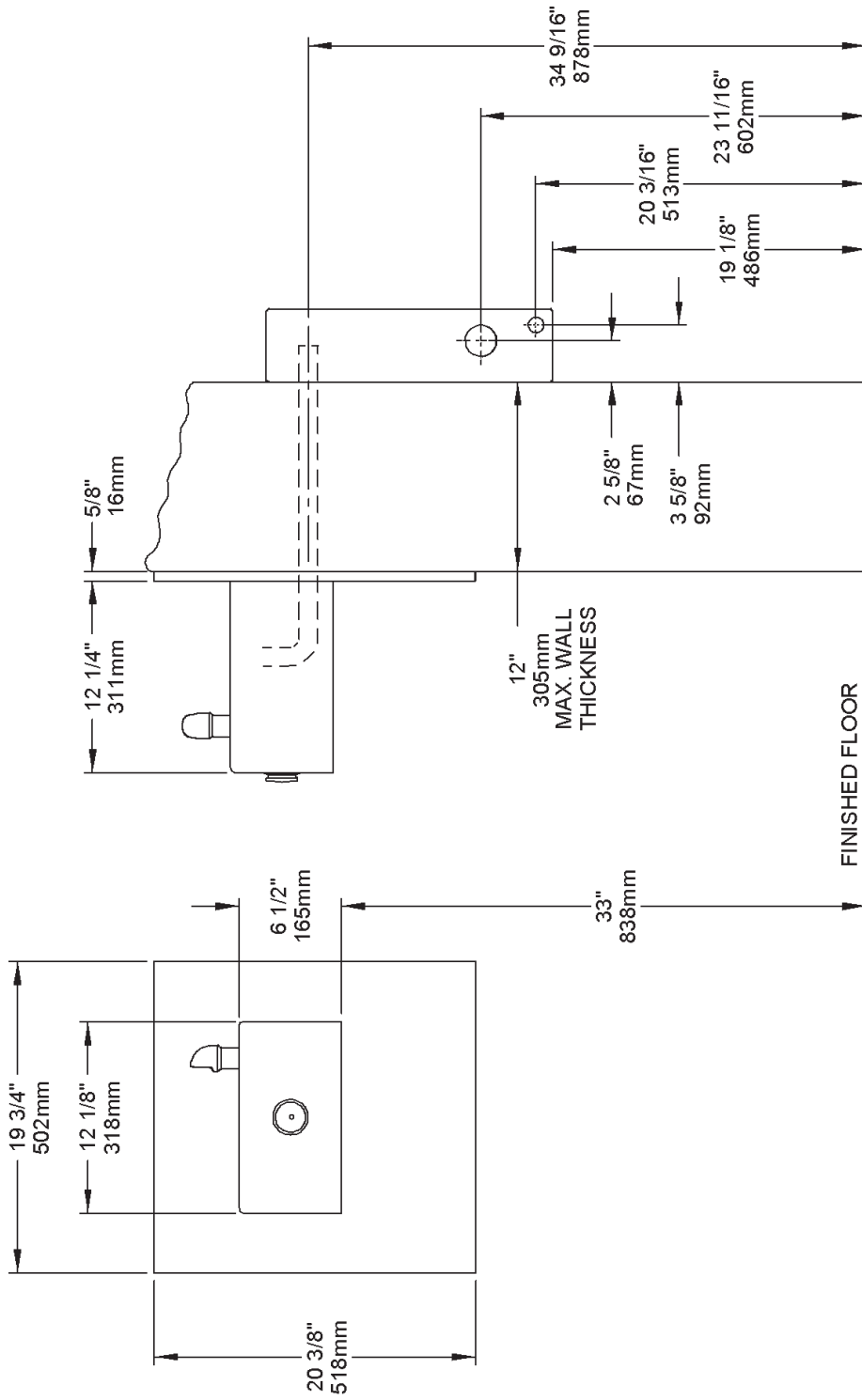

1. Wall should already be framed for the fountain using dimensions shown in Fig. 3. Shown dimensions pertain to installation location. These dimensions are required for compliance with ANSI Standard A117.1. and ADA (Framing shown for reference only).
2. Remove bottom cover from fountain and save the screws.
3. Install the fountain using bolts and washers (not provided). Tighten securely.
4. Attach drain tube to fountain and cut to required length using the freeze resistant box as a guide.
5. Install freeze-resistant box - see box instructions.
6. Replace bottom cover.

**HRFEBP - FR WITH WALL PLATE ASSY.
MOUNTING BOLT AND ACCESS HOLE LAYOUT**

FIG. 5

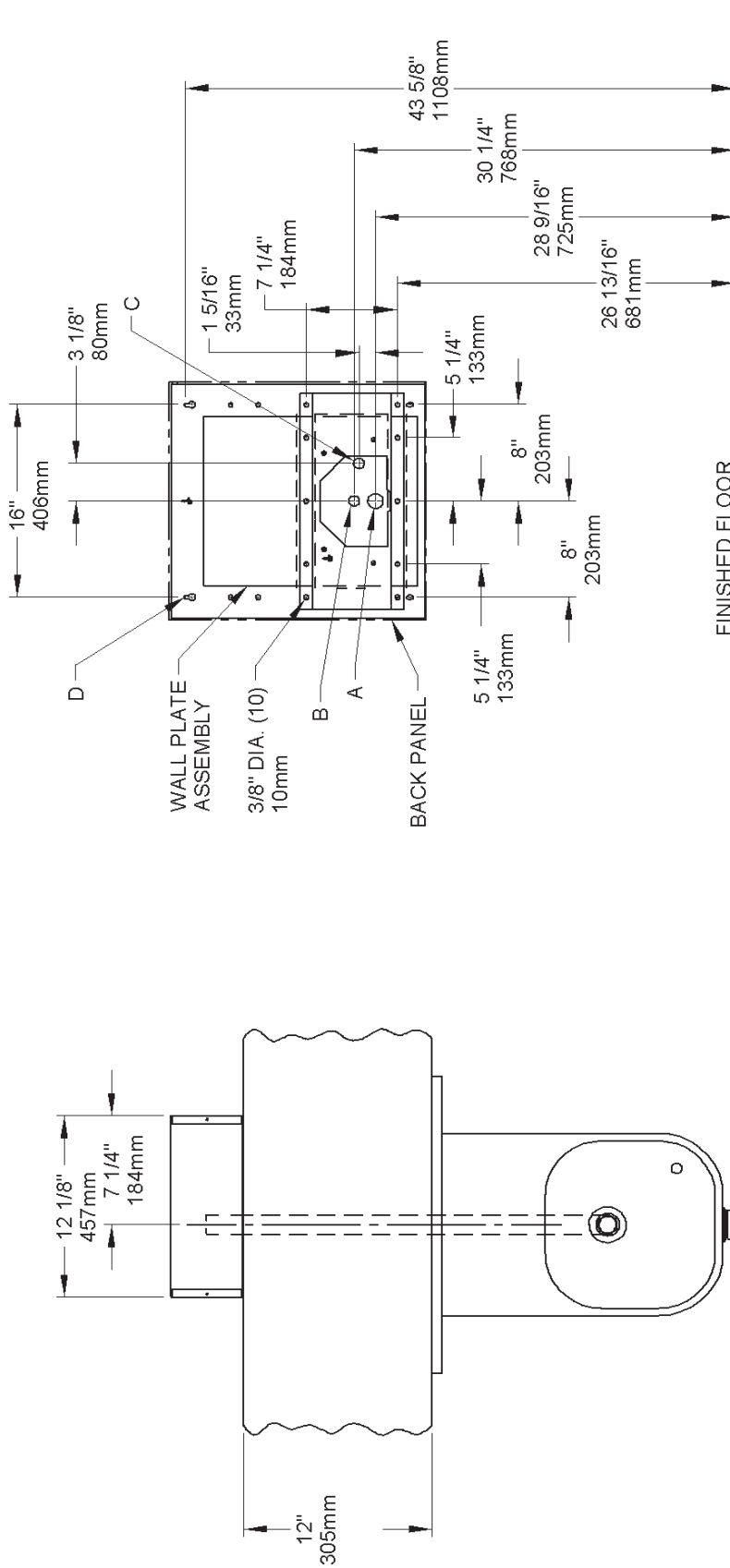

- LEGEND**
- A = 1-3/4" DIA. (44mm) HOLE FOR WASTE LINE
 - B = 7/8" DIA. (22mm) HOLE FOR WATER SUPPLY TUBE
 - C = 7/8" DIA. (22mm) HOLE FOR OPERATING CABLE
 - D = 1/4" DIA. (6mm) HOLES FOR MOUNTING PLATE TO WALL

**HRFEBP - FR WITH WALL PLATE ASSY.
ROUGH-IN DRAWINGS**

FIG. 6

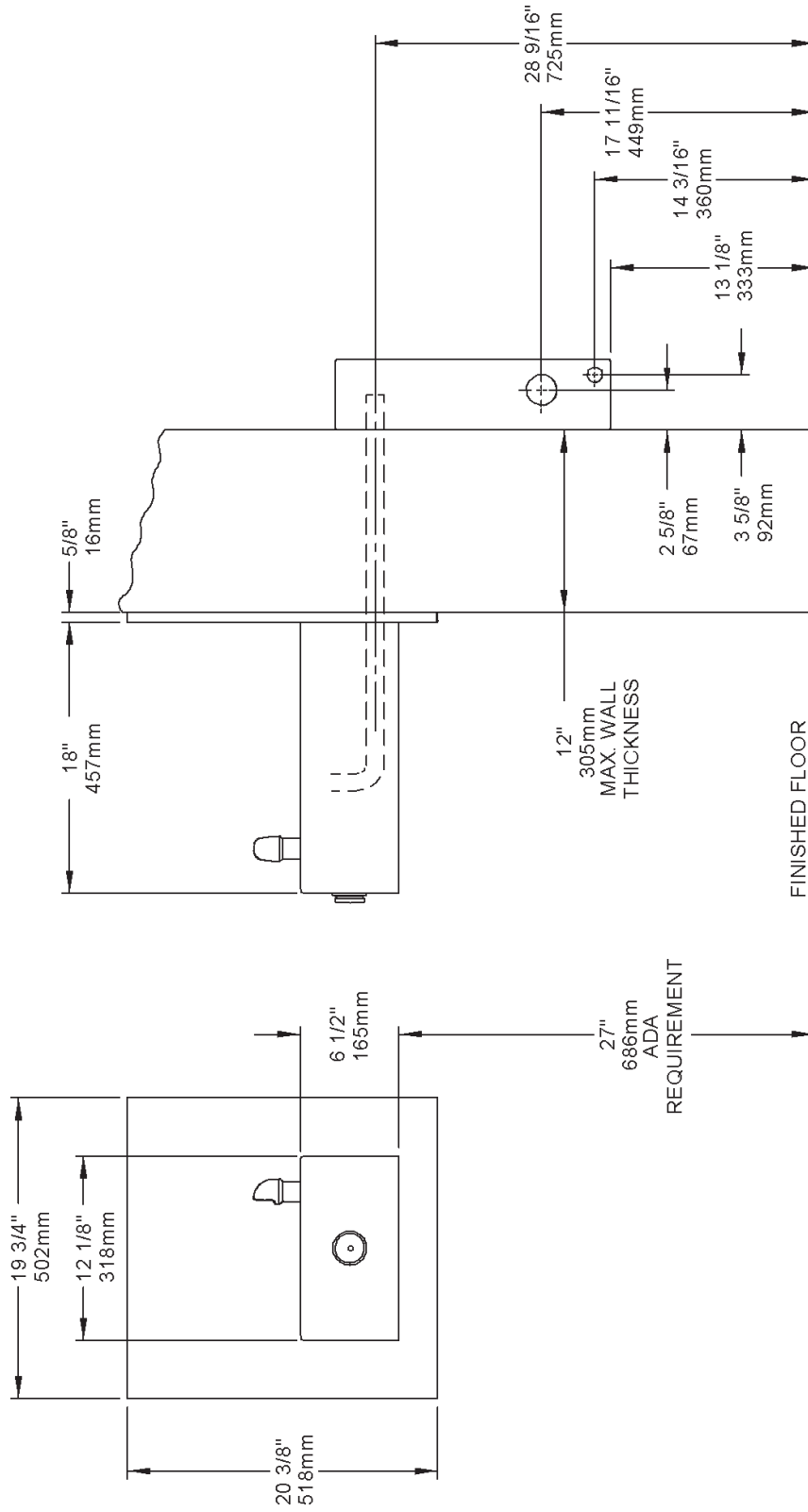

1. Wall should already be framed for the fountain using dimensions shown in Fig. 5. Shown dimensions pertain to installation location. These dimensions are required for compliance with ANSI Standard A117.1. and ADA (Framing shown for reference only).

2. Remove bottom cover from fountain and save the screws.

3. Install the fountain using bolts and washers (not provided). Tighten securely.

4. Attach drain tube to fountain and cut to required length using the freeze resistant box as a guide.

5. Install freeze-resistant box - see box instructions.

6. Replace bottom cover.

**HRFEBP - FR WITH MPW101 MOUNTING PLATE
MOUNTING BOLT AND ACCESS HOLE LAYOUT**

FIG. 7

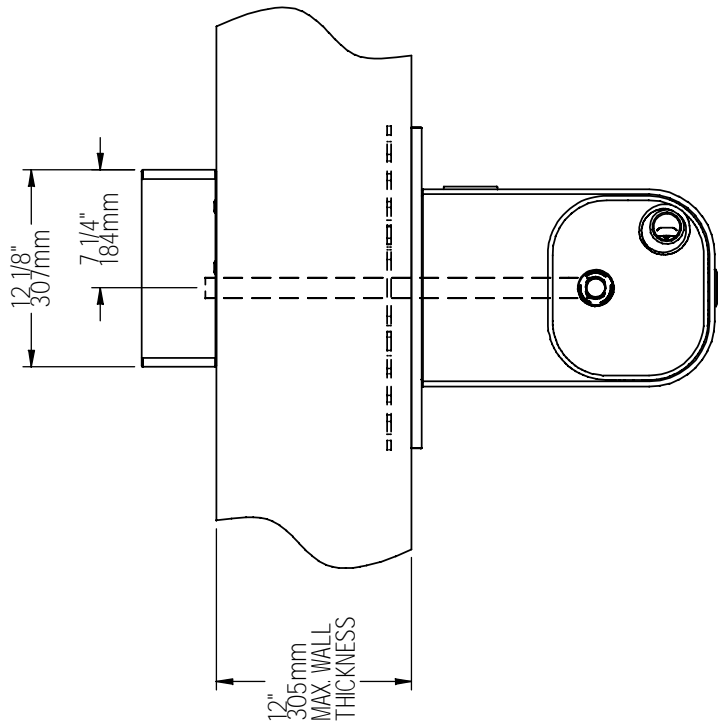
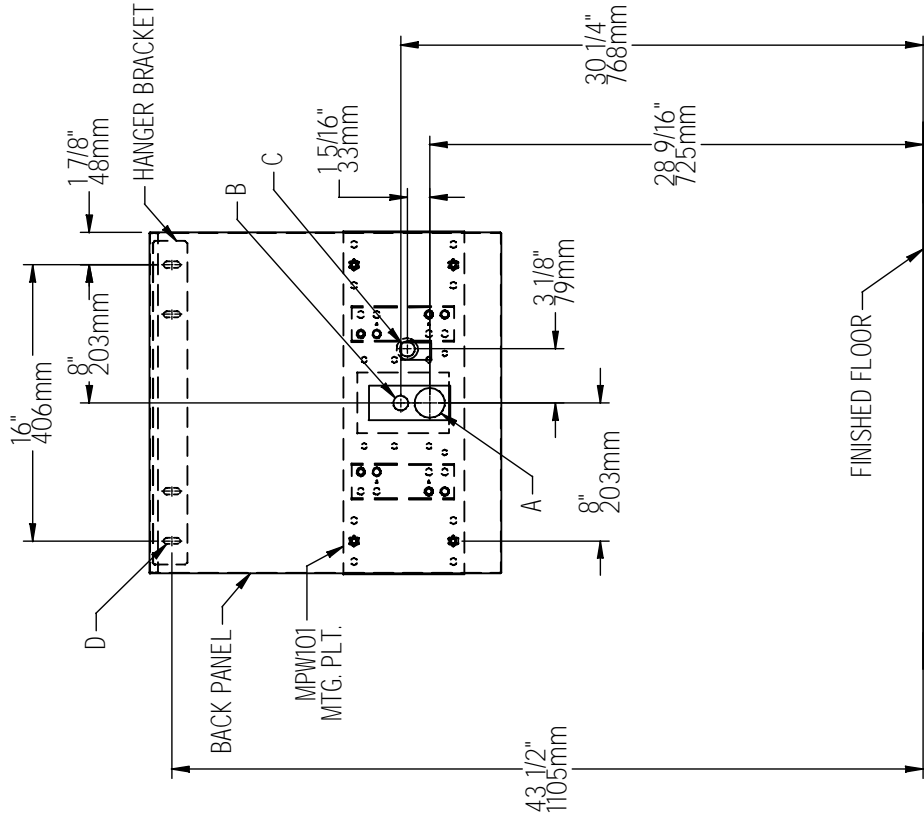

- LEGEND**
- A = 1-3/4" DIA. (44mm) HOLE FOR WASTE LINE
 - B = 7/8" DIA. (22mm) HOLE FOR WATER SUPPLY TUBE
 - C = 7/8" DIA. (22mm) HOLE FOR OPERATING CABLE
 - D = 3/8" DIA. (10mm) SLOTS FOR MOUNTING HANGER BRACKET TO WALL

**HRFEBP - FR WITH MPW101 MOUNTING PLATE
ROUGH-IN DRAWINGS**

FIG. 8

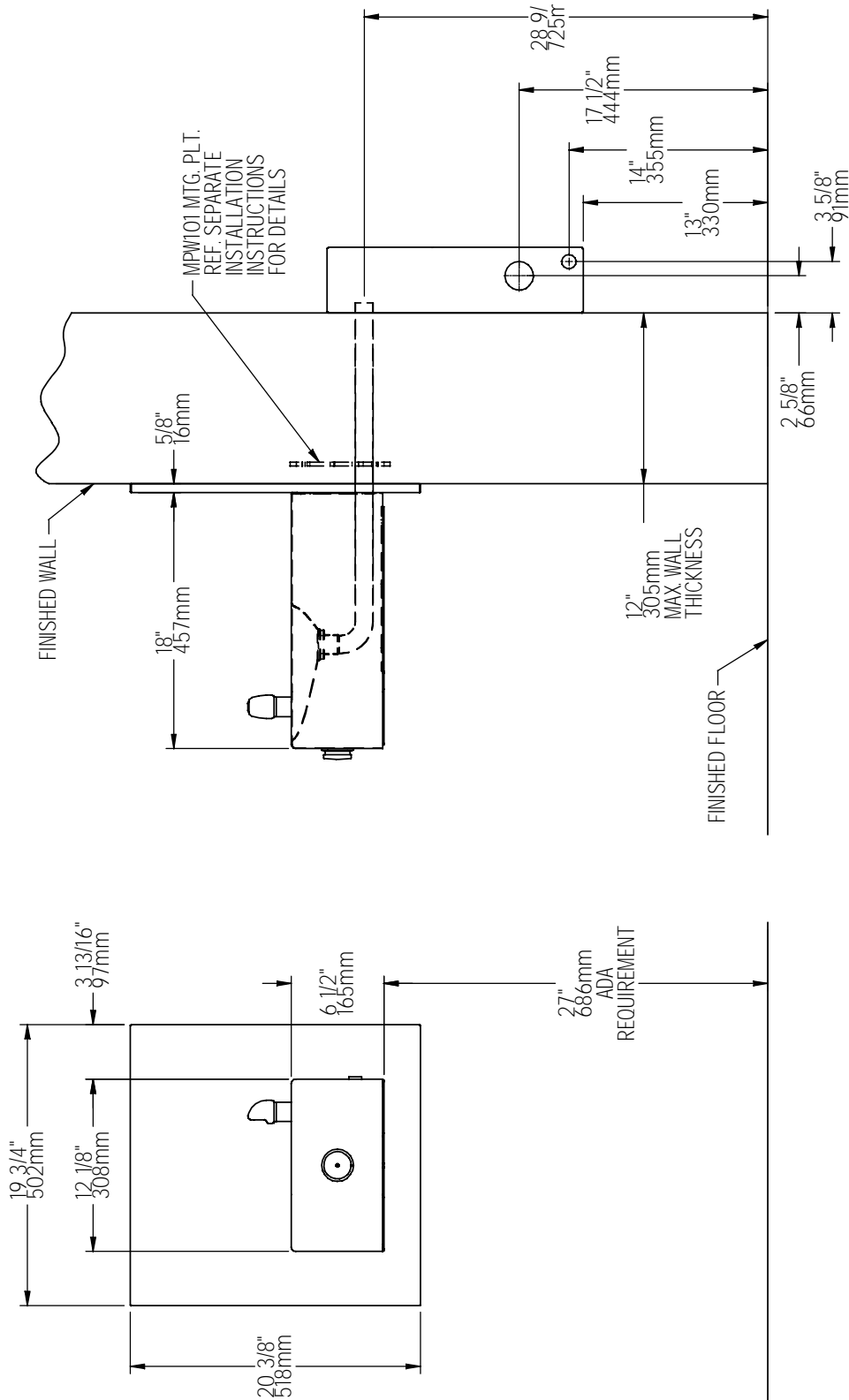

1. Wall should already be framed for the fountains using dimensions shown in Fig. 7. Shown dimensions pertain to installation location. These dimensions are required for compliance with ANSI Standard A117.1. and ADA (Framing shown for reference only).

2. Remove bottom covers from fountains and save the screws.

3. Install the fountains using bolts and washers (provided). Tighten securely.

4. Attach drain tubes to fountains and cut to required length using the freeze resistant boxes as guides.

5. Install freeze-resistant boxes - see box instructions.

6. Replace bottom covers.

**HRFSEBP - FR WITH WALL PLATE ASSY.
MOUNTING BOLT AND ACCESS HOLE LAYOUT**

FIG. 9

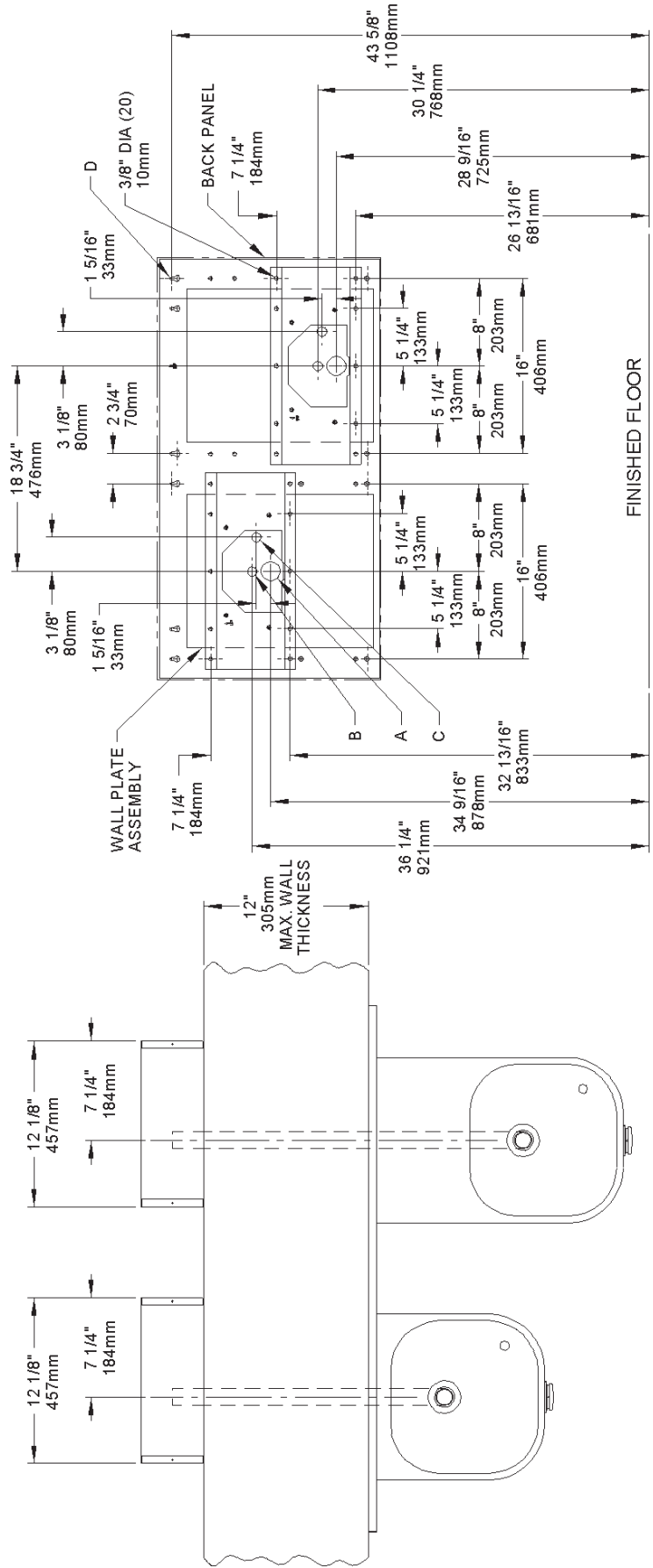

- LEGEND**
- A = 1-3/4" DIA. (44mm) HOLE FOR WASTE LINE
 - B = 7/8" DIA. (22mm) HOLE FOR WATER SUPPLY TUBE
 - C = 7/8" DIA. (22mm) HOLE FOR OPERATING CABLE
 - D = 1/4" DIA. (6mm) HOLES FOR MOUNTING PLATE TO WALL

**HRFSEBP - FR WITH WALL PLATE ASSY.
ROUGH-IN DRAWINGS**

FIG. 10

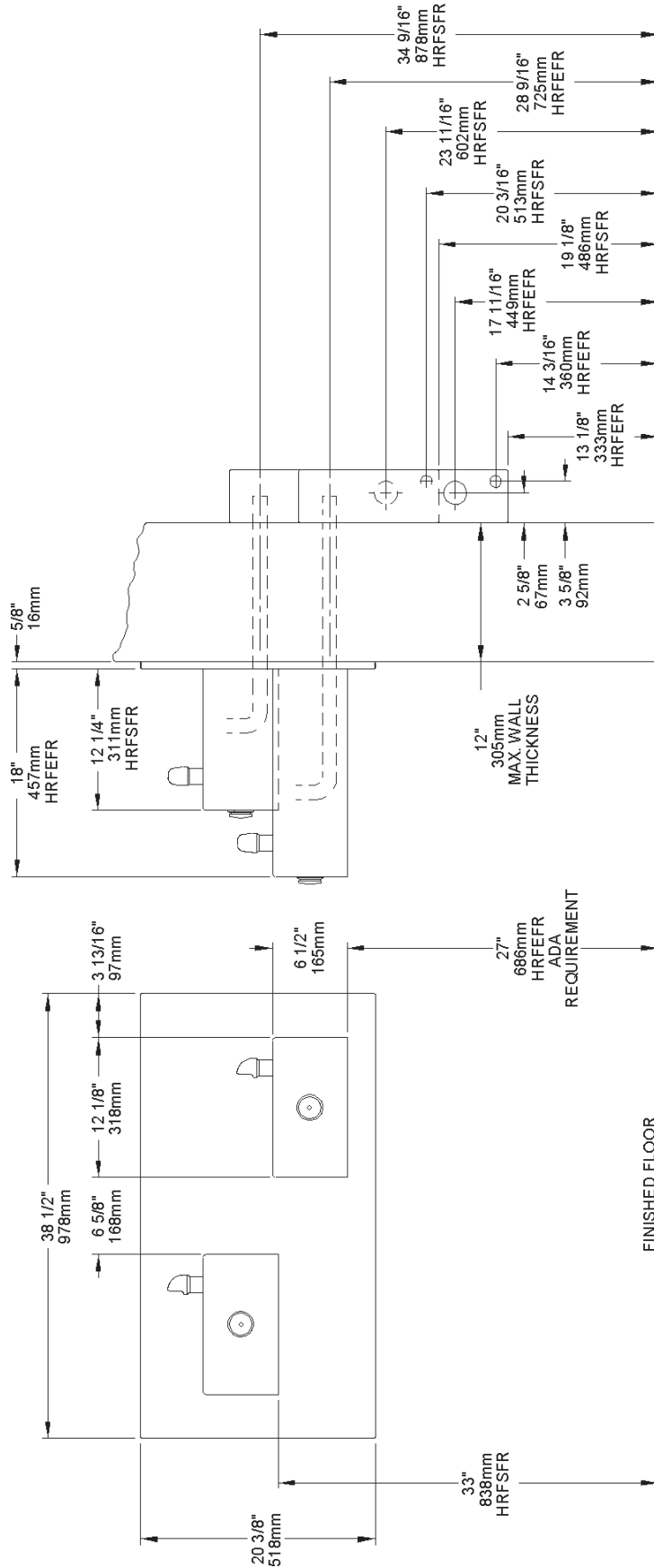

- 1. Wall should already be framed for the fountains using dimensions shown in Fig. 9.** Shown dimensions pertain to installation location. These dimensions are required for compliance with ANSI Standard A117.1. and ADA (Framing shown for reference only).
- 2. Remove bottom covers from fountains and save the screws.**
- 3. Install the fountains** using bolts and washers (provided). Tighten securely.
- 4. Attach drain tubes** to fountains and cut to required length using the freeze resistant boxes as guides.
- 5. Install freeze-resistant boxes** - see box instructions.
- 6. Replace** bottom covers.

**HRFSEBP - FR WITH MPW200 MOUNTING PLATE
MOUNTING BOLT AND ACCESS HOLE LAYOUT**

FIG. 11

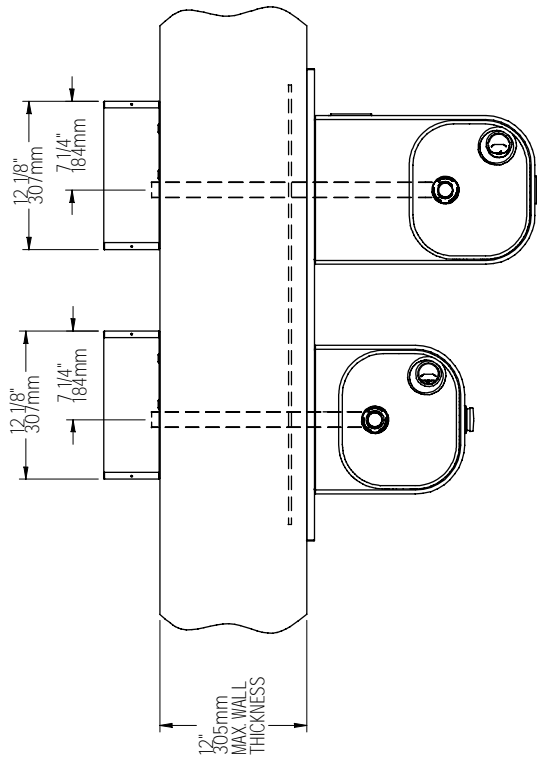
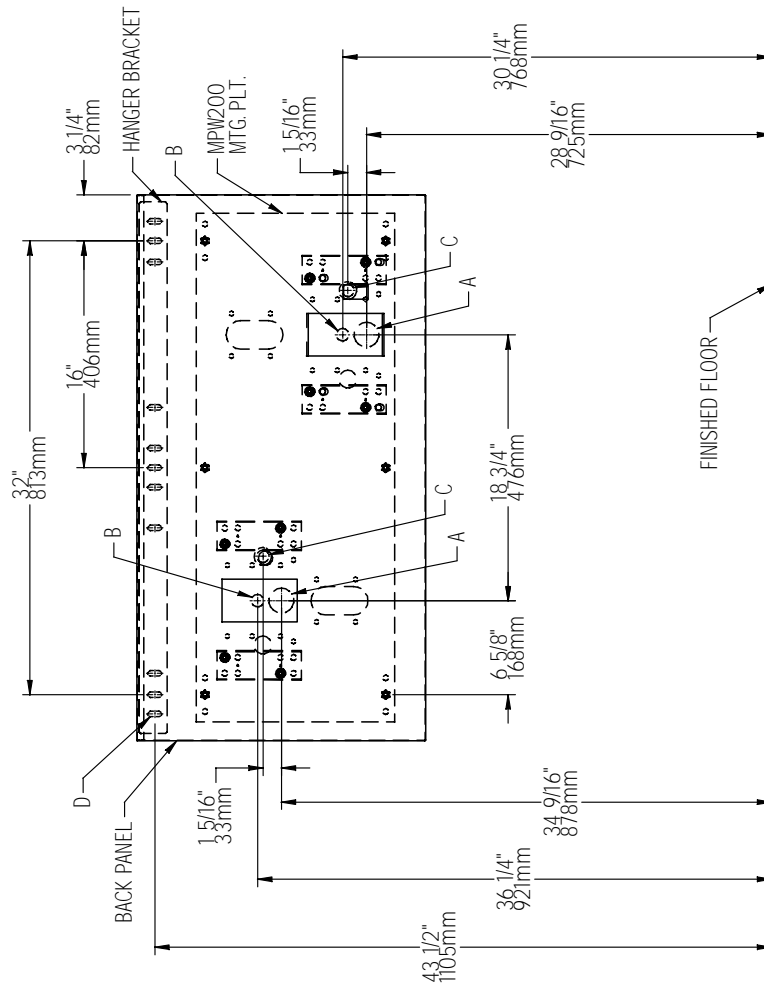

- LEGEND**
- A = 1-3/4" DIA. (44mm) HOLE FOR WASTE LINE
 - B = 7/8" DIA. (22mm) HOLE FOR WATER SUPPLY TUBE
 - C = 7/8" DIA. (22mm) HOLE FOR OPERATING CABLE
 - D = 3/8" DIA. (10mm) SLOTS FOR MOUNTING HANGER BRACKET TO WALL

**HRFSEBP - FR WITH MPW200 MOUNTING PLATE
ROUGH-IN DRAWINGS**

FIG. 12

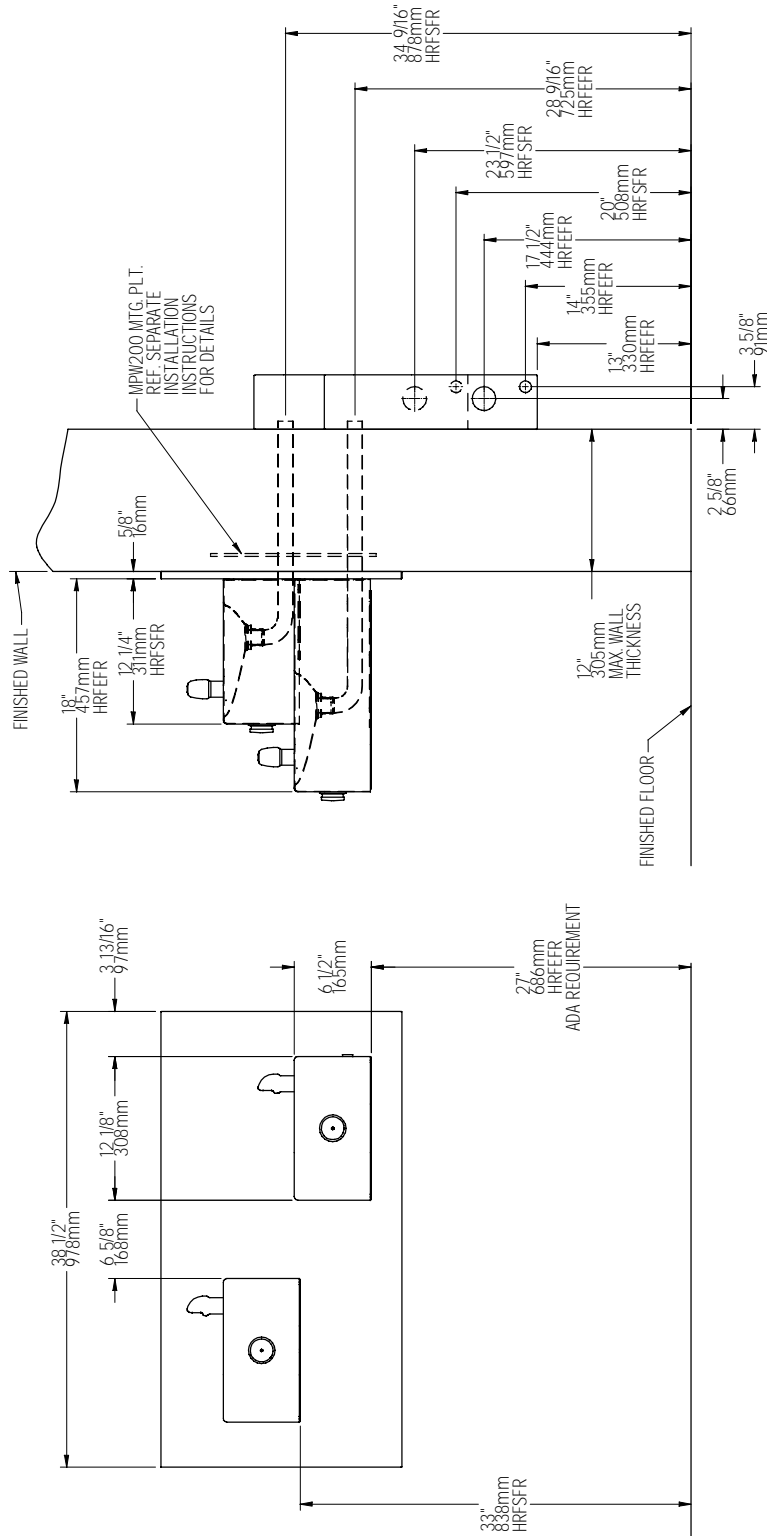

1. **Wall should already be framed for the fountains using dimensions shown in Fig. 11.** Shown dimensions pertain to installation location. These dimensions are required for compliance with ANSI Standard A117.1. and ADA (Framing shown for reference only).
2. **Remove bottom covers from fountains and save the screws.**
3. **Install the fountains** using bolts and washers (provided). Tighten securely.
4. **Attach drain tubes** to fountains and cut to required length using the freeze resistant boxes as guides.
5. **Install freeze-resistant boxes** - see box instructions.
6. **Replace** bottom covers.

**HRFESBP - FR WITH WALL PLATE ASSY.
MOUNTING BOLT AND ACCESS HOLE LAYOUT**

FIG. 13

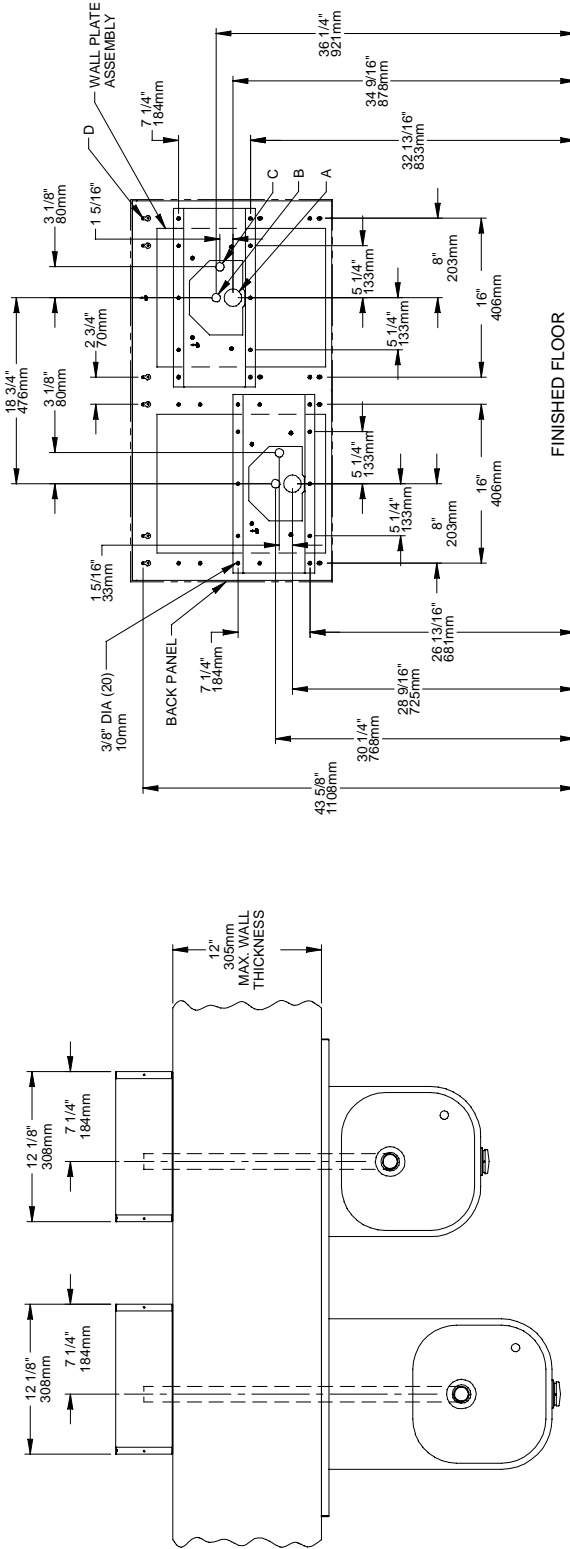

- LEGEND**
- A = 1-3/4" DIA. (44mm) HOLE FOR WASTE LINE**
 - B = 7/8" DIA. (22mm) HOLE FOR WATER SUPPLY TUBE**
 - C = 7/8" DIA. (22mm) HOLE FOR OPERATING CABLE**
 - D = 1/4" DIA. (6mm) HOLES FOR MOUNTING PLATE TO WALL**

**HRFESBP - FR WITH WALL PLATE ASSY
ROUGH-IN DRAWINGS**

FIG. 14

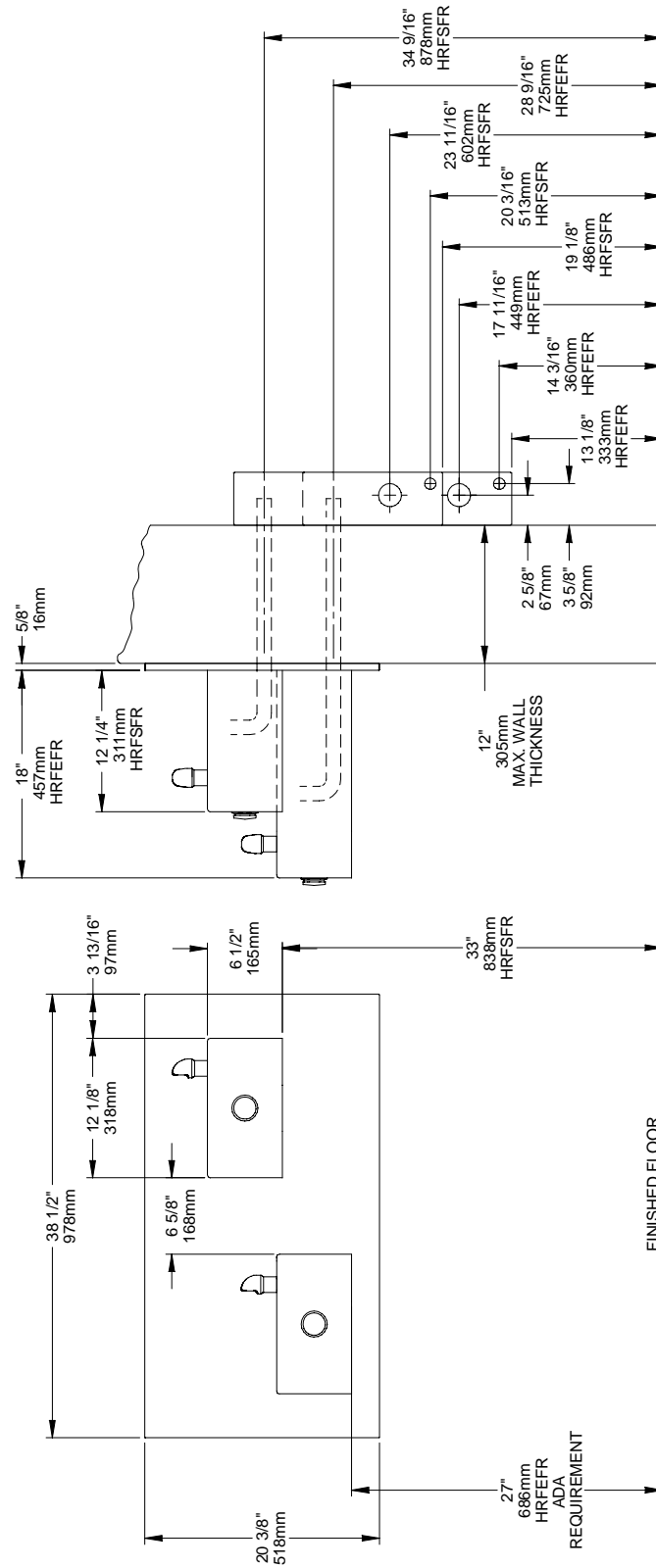

1. Wall should already be framed for the fountains using dimensions shown in Fig.13. Shown dimensions pertain to installation location. These dimensions are required for compliance with ANSI Standard A117.1. and ADA (Framing shown for reference only).

2. Remove bottom covers from fountains and save the screws.

3. Install the fountains using bolts and washers (provided). Tighten securely.

4. Attach drain tubes to fountains and cut to required length using the freeze resistant boxes as guides.

5. Install freeze-resistant boxes - see box instructions.

6. Replace bottom covers.

**HRFESBP - FR WITH MPW200 MOUNTING PLATE
MOUNTING BOLT AND ACCESS HOLE LAYOUT**

FIG. 15

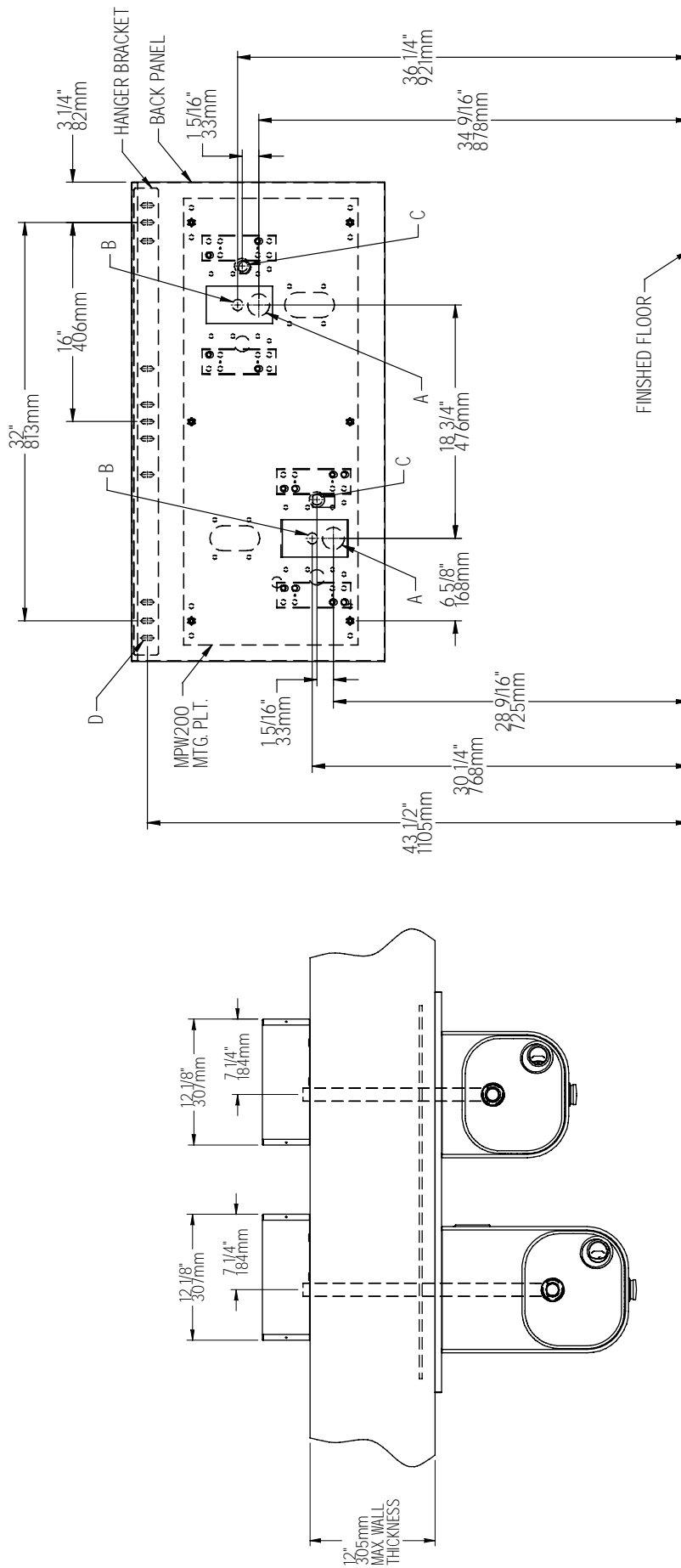

- LEGEND**
- A = 1-3/4" DIA. (44mm) HOLE FOR WASTE LINE
 - B = 7/8" DIA. (22mm) HOLE FOR WATER SUPPLY TUBE
 - C = 7/8" DIA. (22mm) HOLE FOR OPERATING CABLE
 - D = 3/8" DIA. (10mm) SLOTS FOR MOUNTING HANGER BRACKET TO WALL

**HRFESBP - FR WITH MPW200 MOUNTING PLATE
ROUGH-IN DRAWINGS**

FIG. 16

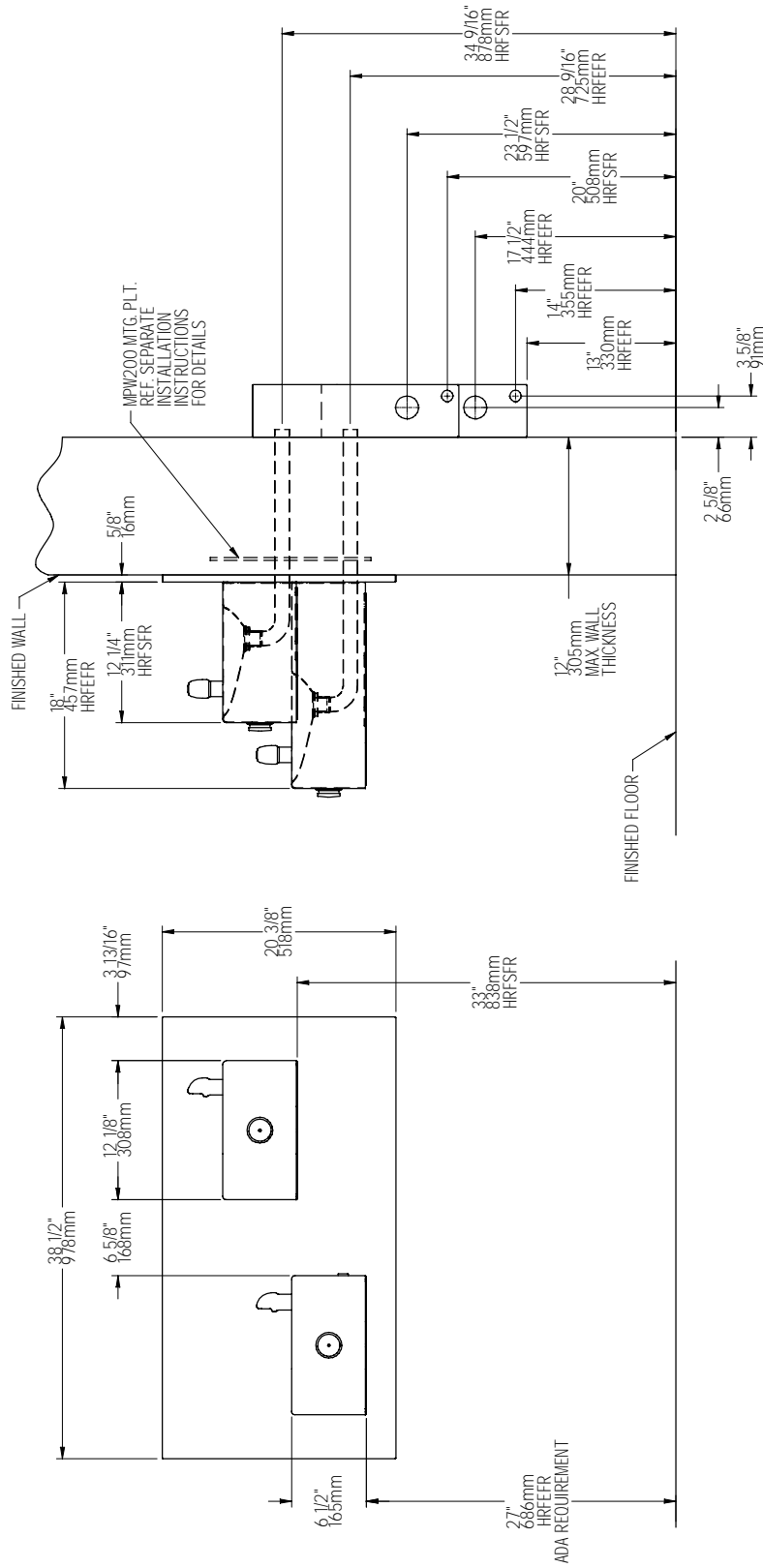

1. Wall should already be framed for the fountains using dimensions shown in Fig. 15. Shown dimensions pertain to installation location. These dimensions are required for compliance with ANSI Standard A117.1. and ADA (Framing shown for reference only).

2. Remove bottom covers from fountains and save the screws.

3. Install the fountains using bolts and washers (provided). Tighten securely.

4. Attach drain tubes to fountains and cut to required length using the freeze resistant boxes as guides.

5. Install freeze-resistant boxes - see box instructions.

6. Replace bottom covers.

CABLE SHEATH ADJUSTMENT

To Increase Free Play



To Reduce Free Play

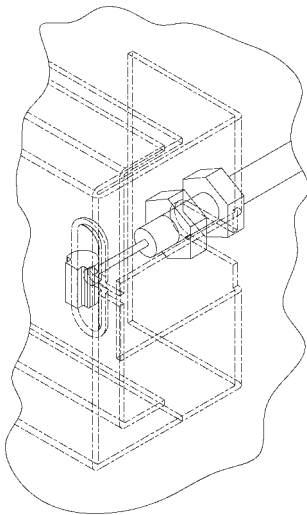

FIG. 17

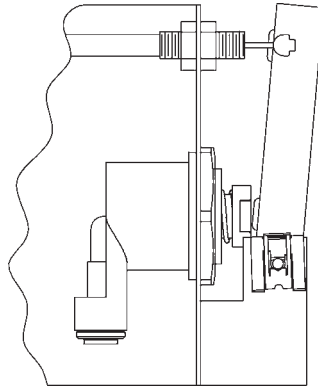

FIG. 18

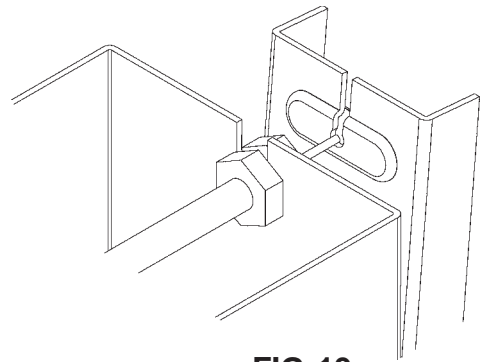

FIG. 19

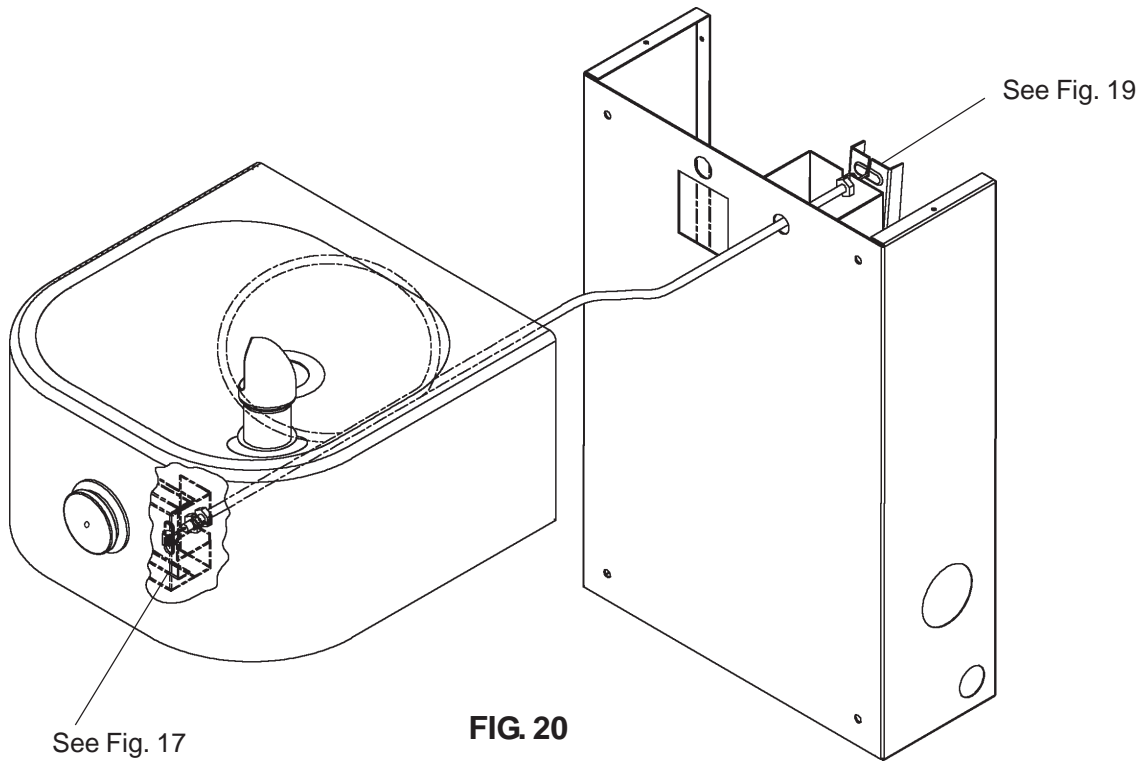

FIG. 20

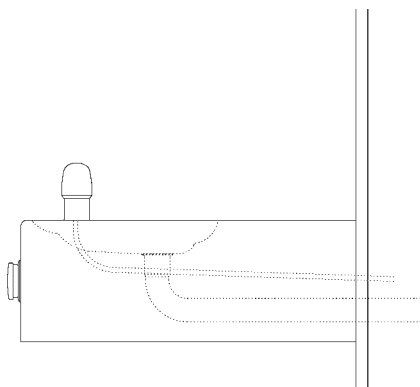

FIG. 21

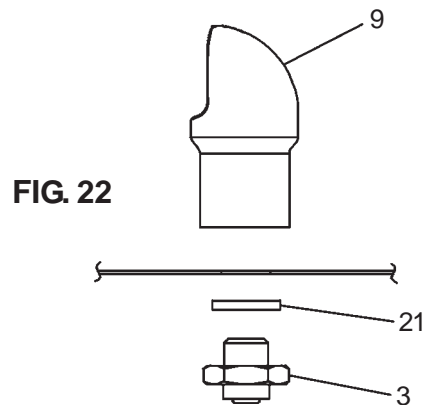

FIG. 22

PARTS LIST

ITEM NO.	PART NO.	DESCRIPTION
1	56092C	POLY TUBING (CUT TO LENGTH)
2	112627543890	SCREW - #10 - 24 X .50 PHTC
3	15009C	NIPPLE ASSY
4	28823C	BRACKET-REGULATOR MOUNTING
5	27945C	BRACKET-BASIN
6	27946C	BRACKET-BASIN PIVOT
7	40045C	HEX NUT 1-5/16
8	40206000	RETAINER
9	98118C	BUBBLER ASSEMBLY
10	45662C	PUSH BUTTON
11	45663C	SLEEVE-PUSH BUTTON GUIDE
12	50198C	SNAP BUSHING
13	51667C	BUMPER-REG. VALVE ASSY
14	55919C	PUSH BUTTON (EXTENSION)
15	70425C	PIVOT ROD
16	28782C	FOUNTAIN ARM - SHORT
	28783C	FOUNTAIN ARM - LONG
17	55000661	BOTTOM COVER PLATE - SHORT
	55000665	BOTTOM COVER PLATE - LONG
18	23187C	BACK PANEL - HRFSBP
	23189C	BACK PANEL - HRFEBP
	27043C	BACK PANEL - HRFSEBP
	27261C	BACK PANEL - HRFESBP
19	75672C	CAP SCREW
20	72000833	WASTE ARM ASSY
21	100322740560	WASHER
22	28158C	WALL PLATE ASSEMBLY - HRFSBP
	28170C	WALL PLATE ASSEMBLY - HRFEBP
	28159C	WALL PLATE ASSEMBLY - HRFSEBP
	28178C	WALL PLATE ASSEMBLY - HRFESBP
23	56280C	EDGE TRIM
24	28846C	BACK PANEL ASSEMBLY-HRFEBP
	28848C	BACK PANEL ASSEMBLY-HRFSEBP
	28849C	BACK PANEL ASSEMBLY-HRFESBP
NS	27089C	HANGER BRACKET-HRFEBP
NS	27090C	HANGER BRACKET-HRFSEBP/ESBP

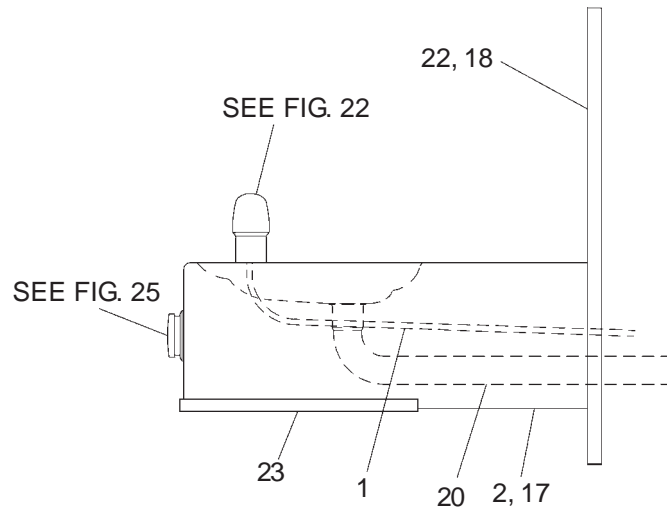
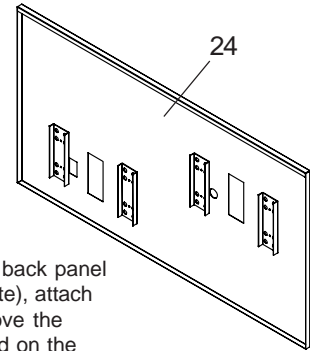

FIG. 23

FIG. 24



Installing Back Panel: When installing back panel assy. (Item 24) with MPW (Mounting Plate), attach channel braces as shown above. Remove the protective backing from the tape installed on the braces. Line up the corresponding holes in the braces and back panel and press firmly in place.

FIG. 25

