

FLEXSTEEL®
OUTDOOR LIVING

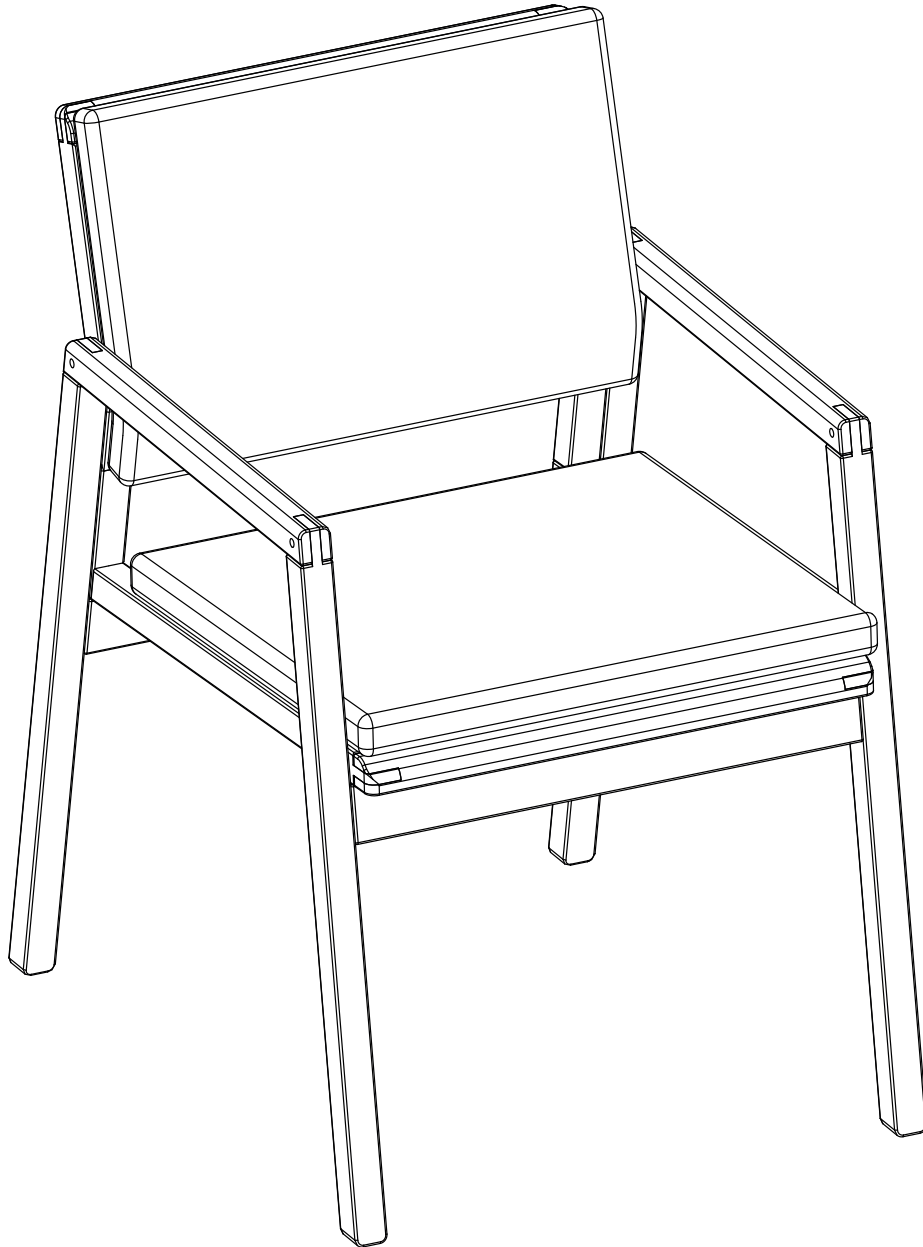

G6300-841

Dining chair

Assembly instructions

Thank you for bringing Flexsteel furniture to your home.

Below are the step-by-step instructions to assemble your new product. Additionally, we have provided an assembly video that you can access through the QR code to the right.

All the parts and tools are included. Let's get started!



PART LIST:

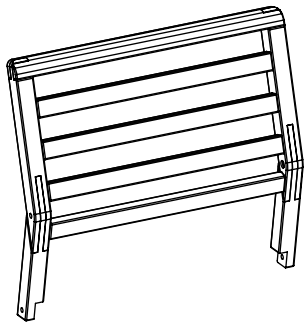

1x backrest

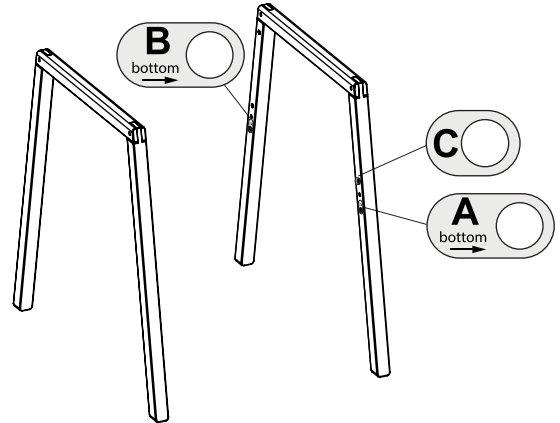

1x left leg (with **A** **B** **C** stickers)

1x right leg (without stickers)

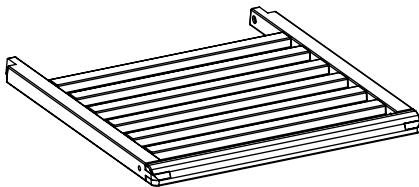

1x seat

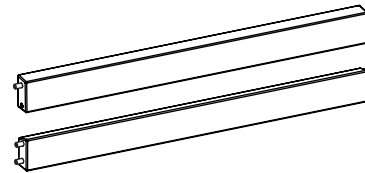

1x front slat - with **A** sticker

1x rear slat - with **B** sticker

FITTINGS AND TOOLS:

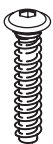

6x screws



2x cam fitting bolts



2x blocking screw

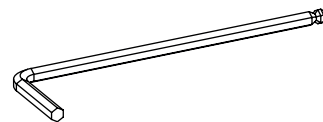

1x hex key with ball ending

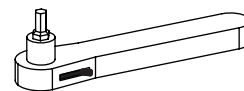

1x ratchet screwdriver

Important Notice: Solid wood furniture is susceptible to natural contractions with changes in humidity and temperature. For smooth assembly, **avoid fully tightening screws initially**; position them first, then gradually tighten all screws evenly once assembly is near completion.

For your convenience, we've implemented a system of stickers to help you determine the correct orientation of each component. Parts marked with stickers are intended for the left-hand side, assuming you are facing the front of your furniture. Letters **(A)**, **(B)** and **(C)** have been assigned to assist you in identifying the precise location for each part.

Step 1

Lay the left leg on its side, ensuring that the pre-drilled holes and the stickers saying **(A)**, **(B)** and **(C)** are facing up. Place it on a secure and stable floor.

Screw the cam fitting bolt into the hole with a metal insert, marked with **(A)** sticker.

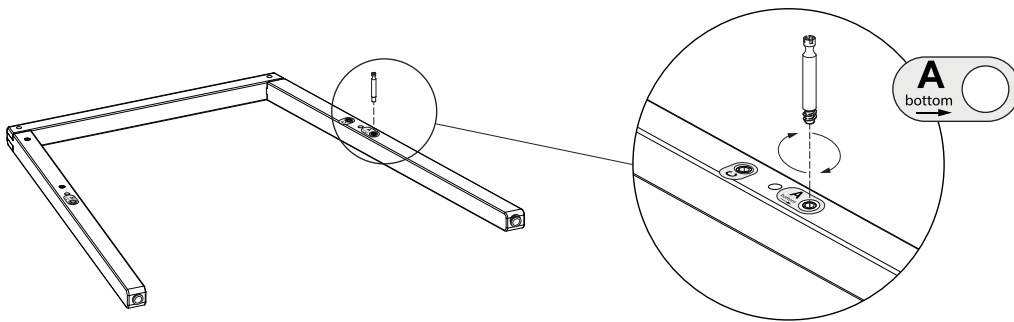

Step 2

Place the front slat, equipped with one dowel, onto the bolt that you just installed. Ensure that you attach it with the side marked with **(A)** sticker, and position the cam fittings facing downwards, as indicated by the arrow on the sticker.

Following that, position the rear slat, equipped with two dowels and marked with **(B)** sticker. The arrows on **(A)** and **(B)** stickers should point toward the bottom of the chair.

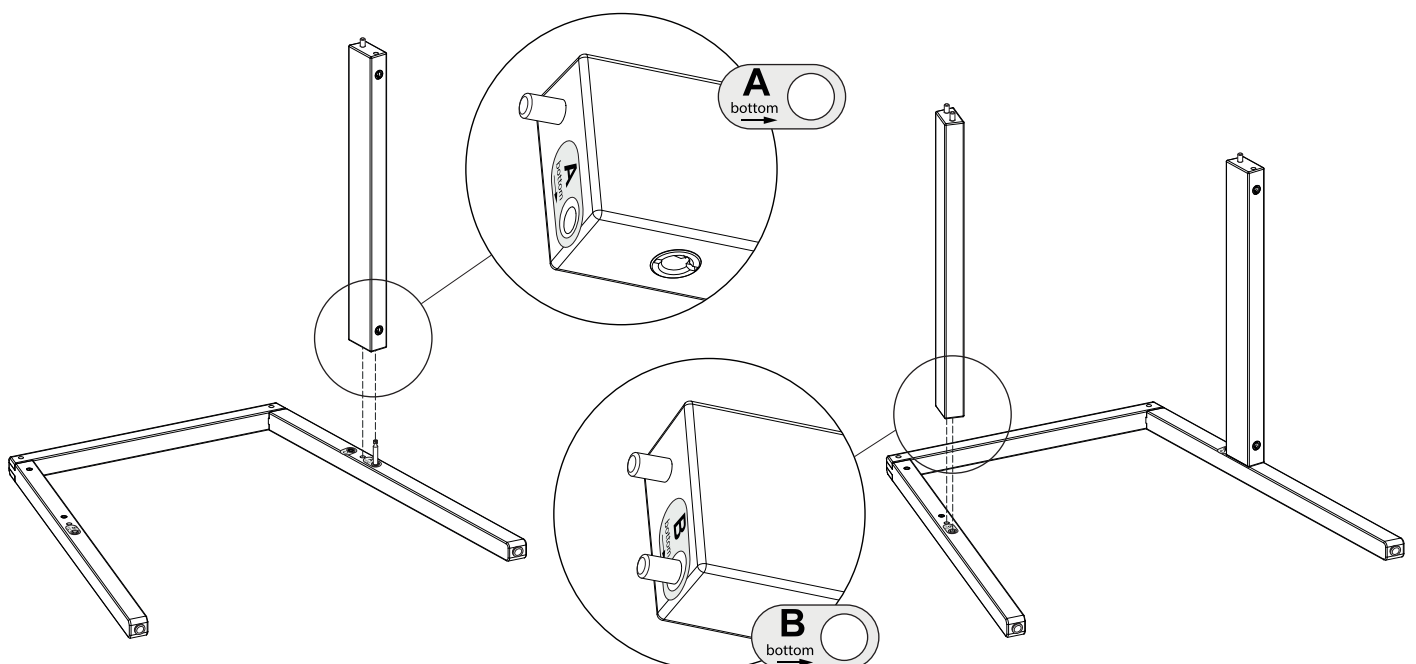

Step 3

Align the seat part on the left leg, ensuring that you match **C** stickers to each other. Attach it with one flathead screw, in the front of the seat. However, refrain from tightening it fully at this point; a few turns are sufficient.

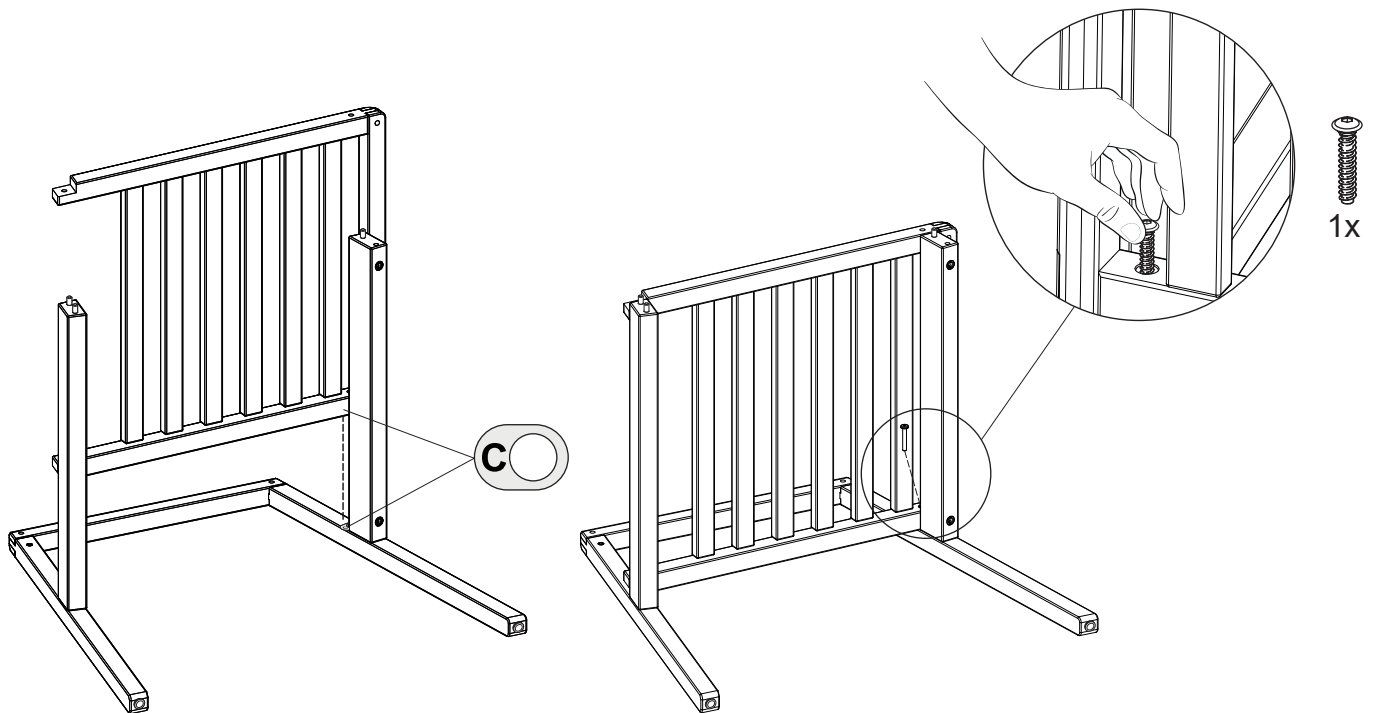

Step 4

Take the backrest part and position it on the left leg. It should fit snugly into the seat part. Attach it to the leg using two flathead screws, but refrain from tightening them immediately.

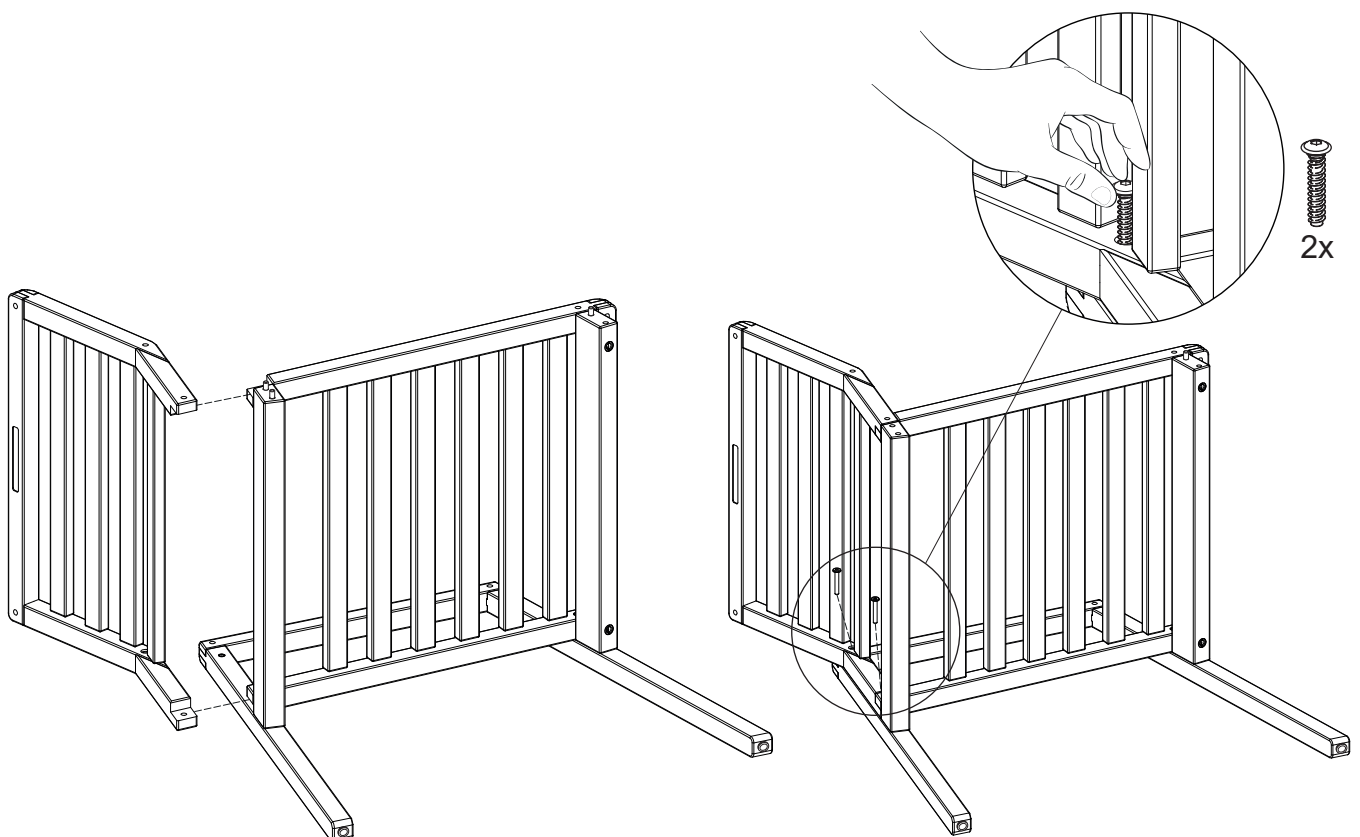

Step 5

Take the right leg and screw the bolt into the metal bottom-most insert, just like you did with the other leg. Position the right leg on the parts you have already assembled.

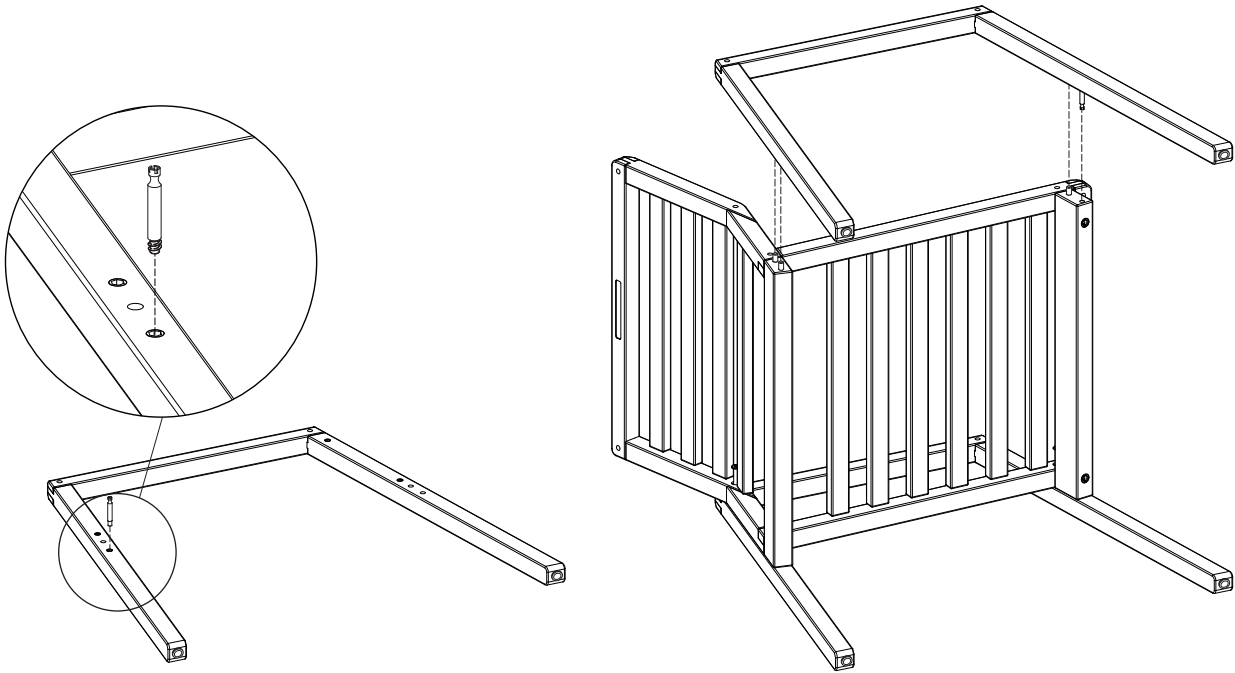

Step 6

Ensure all the parts fit snugly.

Next, take two blocking screws and install them into the cam fittings of the front slat. Tighten them securely using the hex key provided.

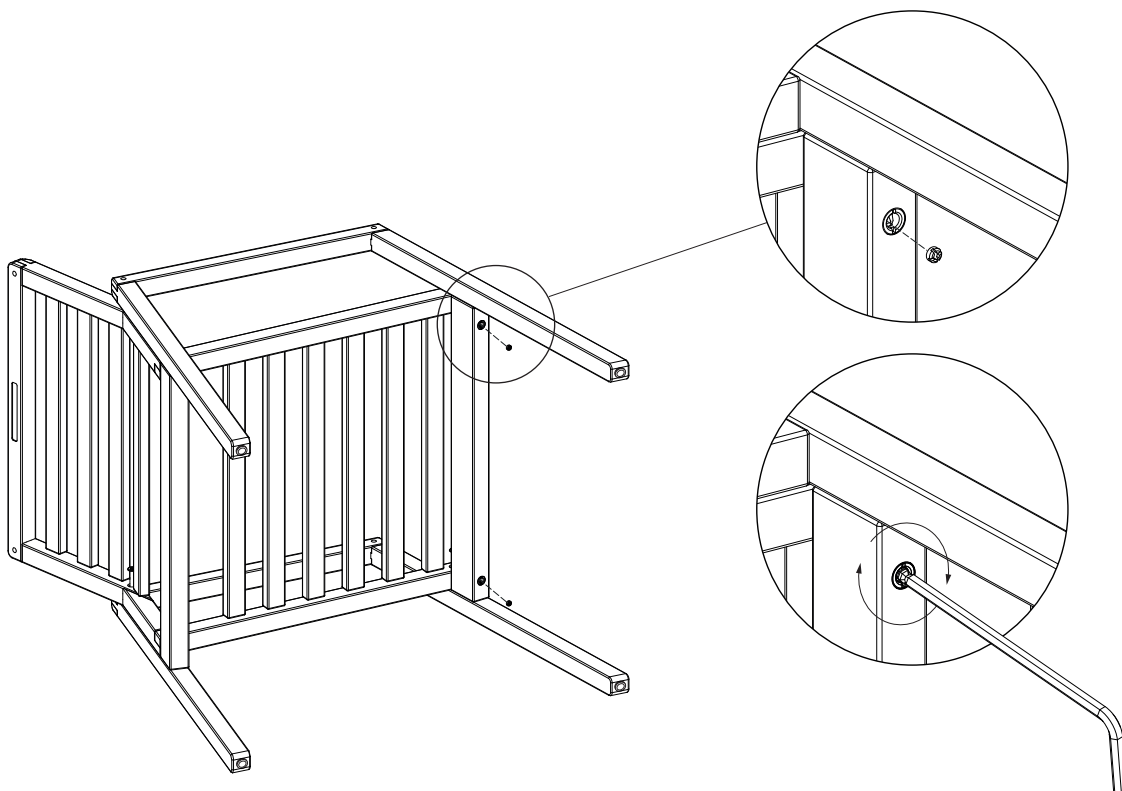

Step 7

Carefully raise the chair into an upright position. Add remaining 3 screws to the right leg, to connect the seat and the backrest to it. Now, tighten all the flathead screws using the tool of your choice.

Important: Add a few turns to each screw until they are evenly tightened; avoid tightening them fully one by one.

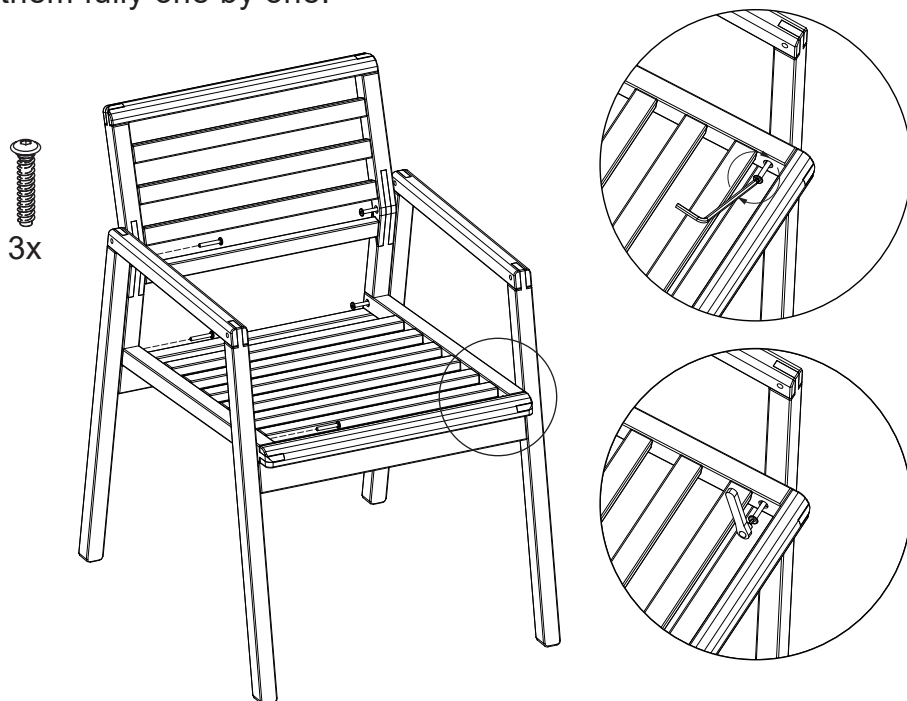

Ball-ended hex key allows you to reach the slot in the screw head at an angle, facilitating the assembly.



Alternatively, you can also use the provided ratchet screwdriver. Make sure to switch it to the correct position.

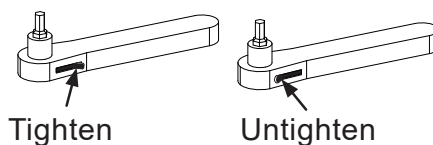

Step 8

Attach the cushions (boxed separately) to the frame by fastening the velcro straps to the slats in the locations shown below. The zipper of the back cushion should be facing down, towards the seat cushion. The zipper of the seat cushion should face the back of the chair.

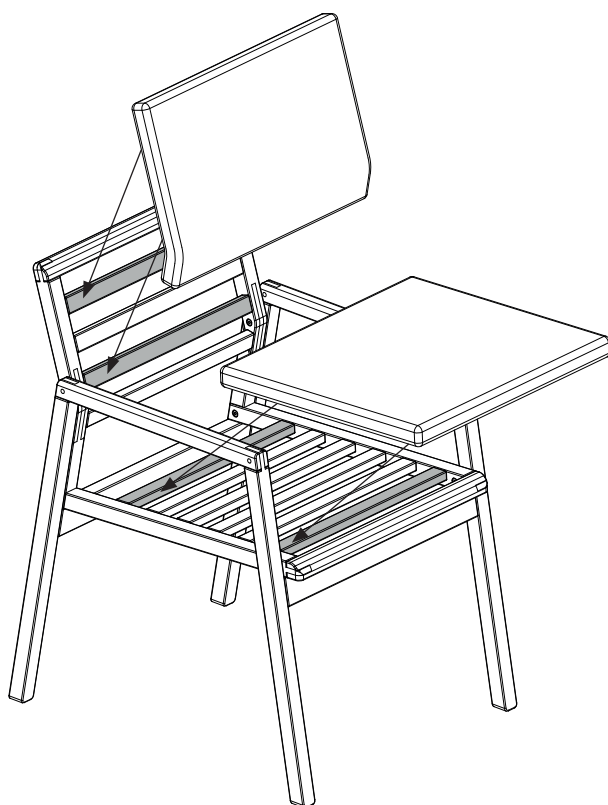

Product care tips

Cleaning and Maintenance:

- **Regular Cleaning:** Using a damp cloth or sponge, wipe down the chair regularly to remove dirt, dust, and other debris.
- **Gentle Cleaning Agents:** For deeper cleaning, use mild soapy water on the wood and a fabric-friendly cleaner for the removable cushions. Avoid harsh chemicals that may harm the wood or fabric.
- **Wipe dry** if exposed to chlorine-rich water.
- **Spot Test:** Before cleaning the entire chair, perform a spot test on an inconspicuous area to ensure the cleaning agents do not cause any adverse effects.
- **Avoid Sharp Objects:** Steer clear of using sharp objects or abrasive materials on the wood to prevent scratches.
- **Cushion Care:** Remove or cover cushions during heavy rain or when not in use to prevent them from getting soaked. If the cushions do get wet, allow them to air dry thoroughly.

Storage:

- **Avoid direct sunlight exposure** to prevent fading or change in color.
- To prolong the life of your outdoor furniture, we recommend using furniture covers when not in use.
- **During winter and inclement weather:** If possible, store the furniture indoors during the winter or when the weather is unfavorable. If indoor storage is not available, we recommend using furniture covers to protect them from weather conditions.
- The furniture is equipped with feet to protect against moisture from the ground. If possible, place them on a hardened surface, avoiding direct contact with the ground. During extended periods of non-use or inclement weather, it is advisable to store the chair on a solid and level surface to minimize prolonged exposure to uneven or damp ground.

Usage:

- **Distribute weight evenly** on the chair to avoid unnecessary stress on specific areas. Do not step on the seats.
- **Avoid Extreme Temperatures:** Protect the chair from prolonged exposure to extreme temperatures to prevent potential damage.
- **Periodically check** for any loosening of the structure - tighten screws if necessary.

F L E X S T E E L[®]

CUSTOMER SERVICE

Call toll-free: 1-888-415-3979

Monday-Friday | 8:00 a.m.-5:00 p.m. (Central Time)

(Phone number is not valid in Mexico; toll-free in the
U.S.A and Canada only)

Email: customersolutions@flexsteel.com