

# FLEXSTEEL®

## Flexsteel Power Recliner with Power Headrest







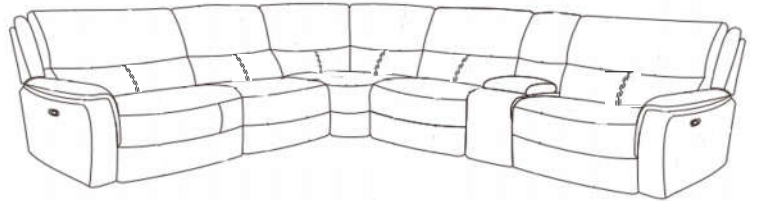

### IMPORTANT NOTE

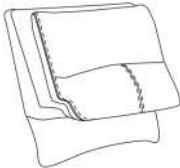
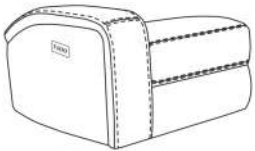
Read these instructions carefully, and familiarize yourself with each procedure before assembling the furniture. Check that you have all the component parts, and familiarize yourself with each part before proceeding.

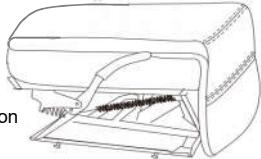
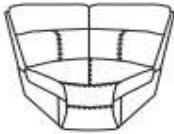
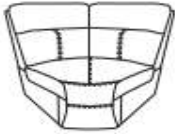
Take all the fittings out of the plastic bag and separate them into groups. Ensure you have enough space to lay out all the parts before assembly. To prevent damage to the parts, we recommend that you assemble the unit on a soft, level surface.

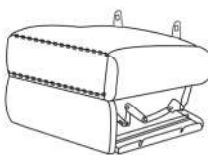

### Part List

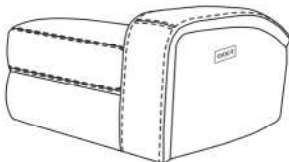
Part	Description	Model	Part	
A	LSF Dual power recliner		 A1 Back cushion 1 piece	 A2 Seat cushion 1 piece
B	Manual power armless chair		 B1 Back cushion 1 piece	 B2 Seat cushion 1 piece
C	Wedge			
D	Armless chair		 D1 Back cushion 1 piece	 D2 Seat cushion 1 piece
E	Console			
F	RSF Dual power recliner		 F1 Back cushion 1 piece	 F2 Seat cushion 1 piece

# Assembly Instructions

## STEP 1

Detach the wall plug transformer from the bottom of Seat of LSF/RSF recliner (A2, F2). (See Figure 1.) , release Power core from the middle rear of armless (B2, D2) and console (E) (See Figure 2.).

Figure 1

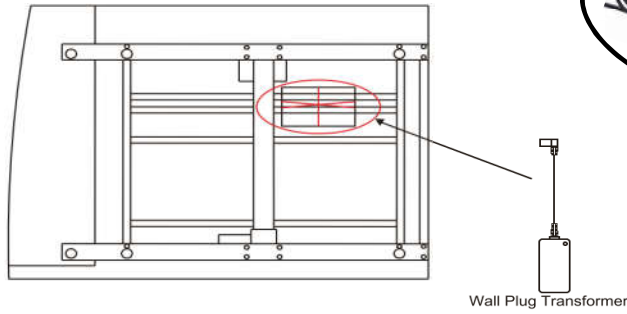
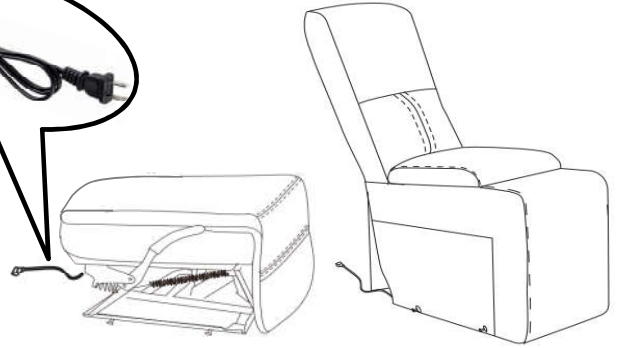

Figure 2



## STEP 2

Attach the Back to the Seat. Ensure the latches fit well. (See Figure 3.)



Figure 3

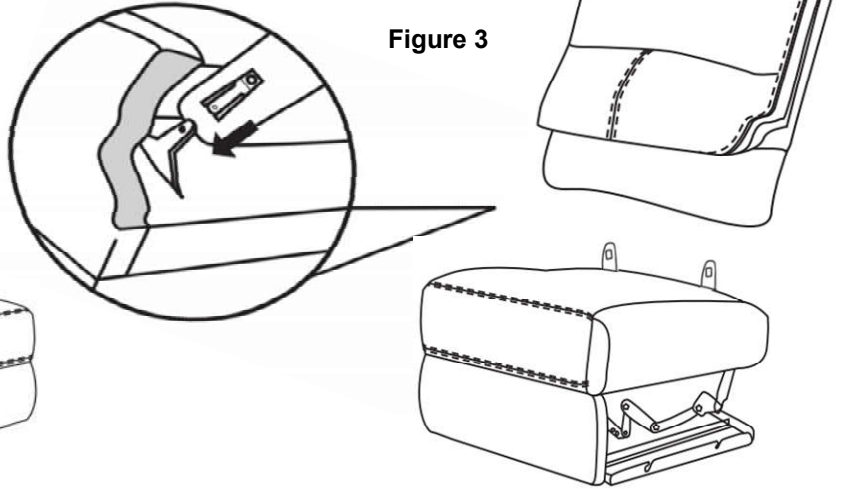

## STEP 3

Position your product in the area of its intended use and connect together using the sectional connectors. (See Figure 4.)

Figure 4

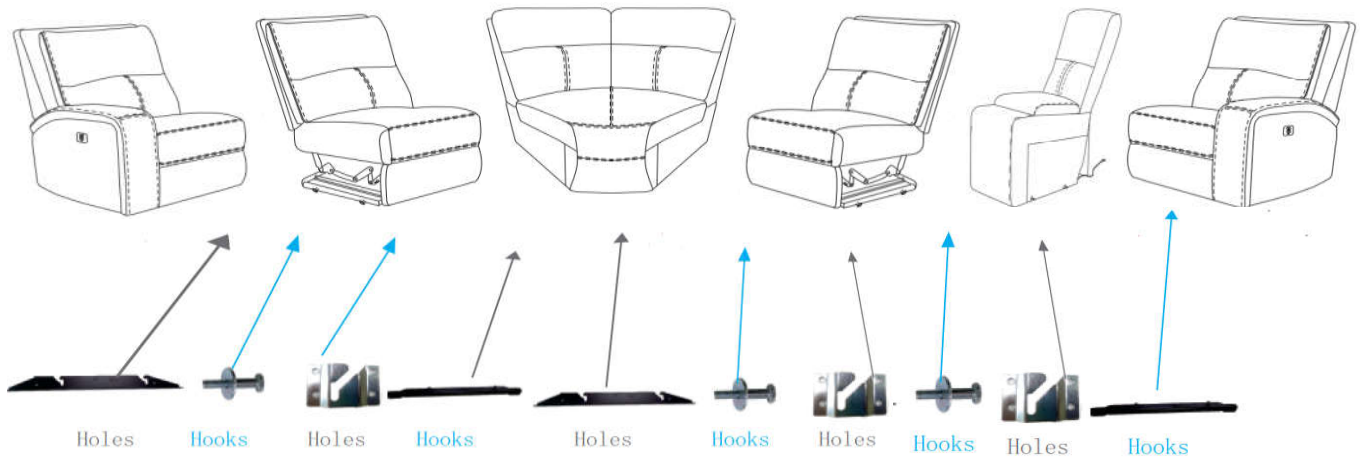

#### STEP 4

Flip up the back flaps, and remove the headrest cables at the middle bottom from the Backs (A1, F1). Plug the Headrest connectors (if applicable). (See the Figure 5.)

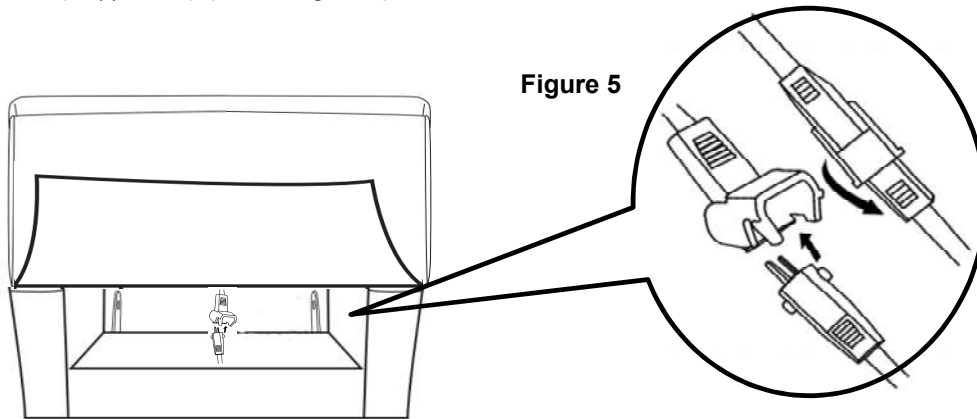

#### STEP 5

Attach the power transformer cord found in **STEP 1** to the matching Plug found at the bottom rear of The dual Left and Right power recliner as seen below . Make sure to close the clip lock to prevent the connection from coming loose. See the Figure 6.)

Figure 6

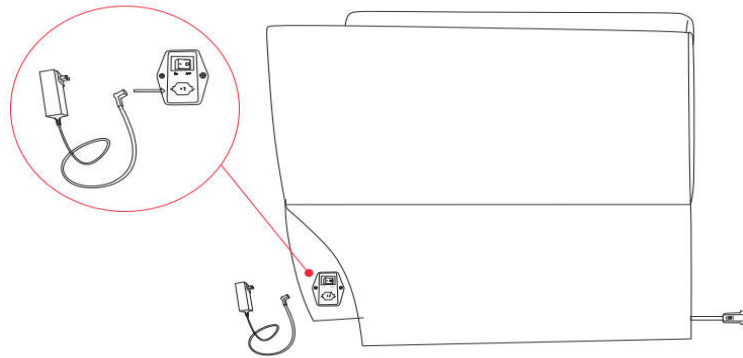

#### STEP 6

Fasten the back flap to the bottom of the furniture. (See Figure 7.)

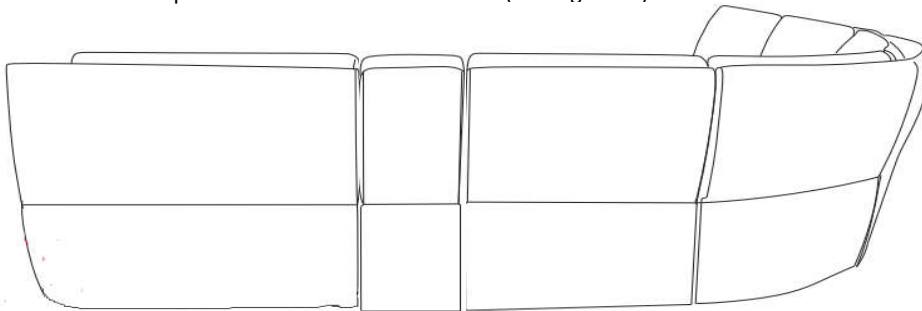

Figure 7

#### STEP 7

Plug the transformer into a nearby outlet, still making sure it is clear of the metal base.

## Care and Maintenance

- To avoid any risk of suffocation to children or pets, dispose of all plastic bags immediately.
- To ensure proper performance, occasionally check for loose screws and tighten as needed.
- If the reclining functions are not working properly, check for loose cable connections before