

WT151M & WT152M

DuoFit™ In Wall Tank System
 For 2x6 & 2x4 Wall Stud Installation
 Dual-Max®, 1.6gpf/6.0Lpf & 0.9gpf/3.4Lpf
 Adjustable Height 15" - 19"

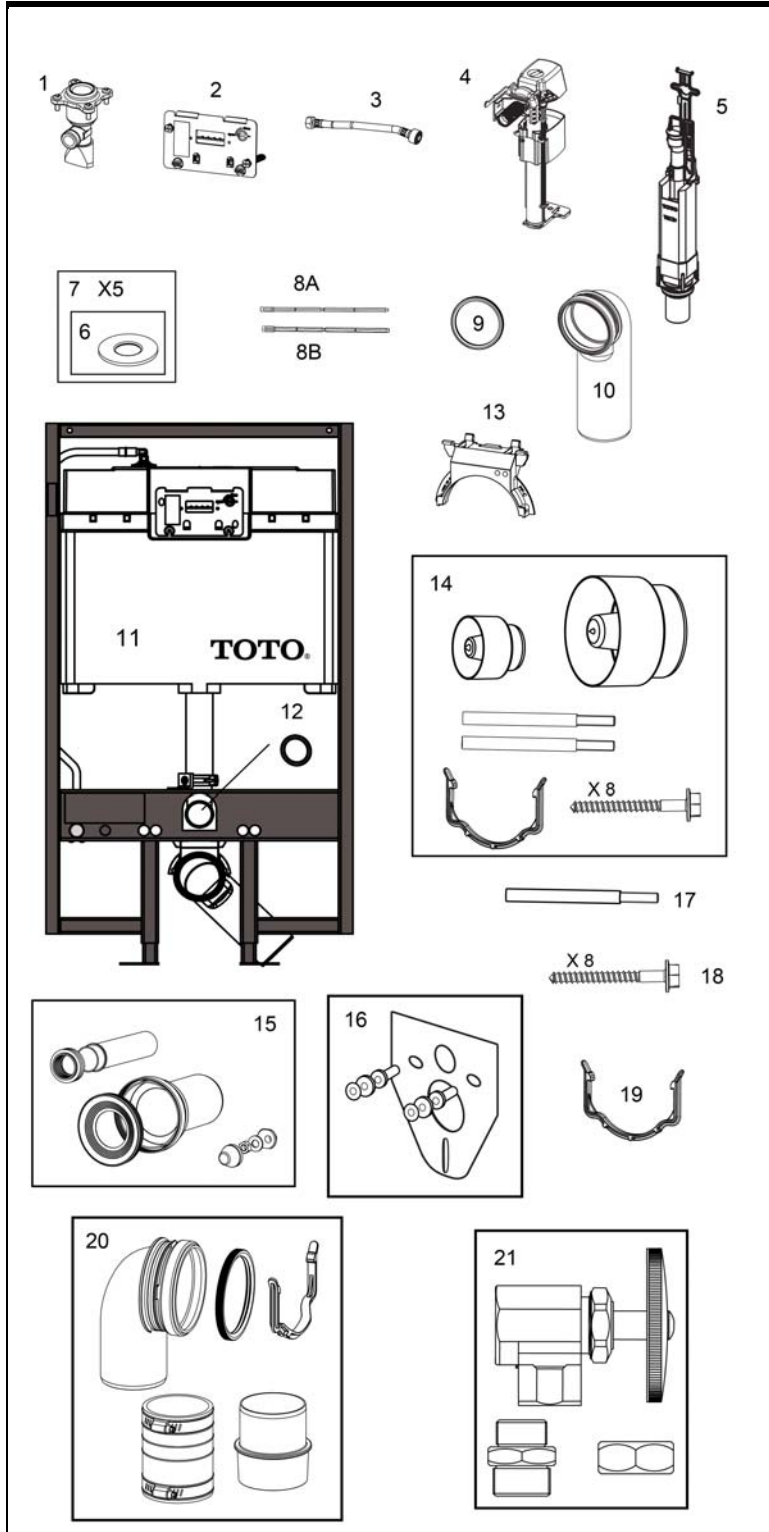

Items	Part No	Description
1	THU329	Stop Valve
2	THU321	Actuator
3	THU323 THU294	Fill Valve Hose (Braided Nylon) Fill Valve Hose (Stainless Steel)
4	THU134	Fill Valve Assembly w/ bracket & filter
5	THU322	Flush Valve Assembly w/ hold down bracket
6	9BU076	Seal Gasket for Flush Valve (1 piece)
7	THU367	Seal Gasket for Flush Valve (5 pieces)
8A	9AU283	Red Push Rod (Partial Flush)
8B	9AU270	Blue Push Rod (Full Flush)
9	9BU086	Gasket for Outlet Pipe Elbow
10	THU327 THU335	Outlet Pipe Elbow for 2x6 wall - HDPE Outlet Pipe Elbow for 2x6 wall - Cast Iron
11	THU313	HD Plastic Tank w/ O-Ring & Foam
12	9BU087	O-Ring for Inlet Pipe
13	9AU282	Bracket for Outlet Pipe Elbow
14	THU320	Mounting Hardware Parts Bag
15	THU334#01	Toilet Connection Assembly Parts
16	THU316	Sound Damper Pad Set
17	6BU033	Threaded Rod Screw M12 x 180
18	6BU035	Lag Screws (x8)
19	9AU273	Lower Bracket for Outlet Pipe Elbow
20	THU343	2x4 Outlet Drain Kit
21	THU383	Washlet Connection Kit

Note:

Product Number Explanations

(WT) In Wall Tank
 (151) Model w/ Pex Supply line
 (152) Model w/ Copper Supply Line
 (M) Dual-Max®

Actual Product may vary slightly from illustration.