

2122BK

NAPLES 3-LIGHT WALL LANTERN

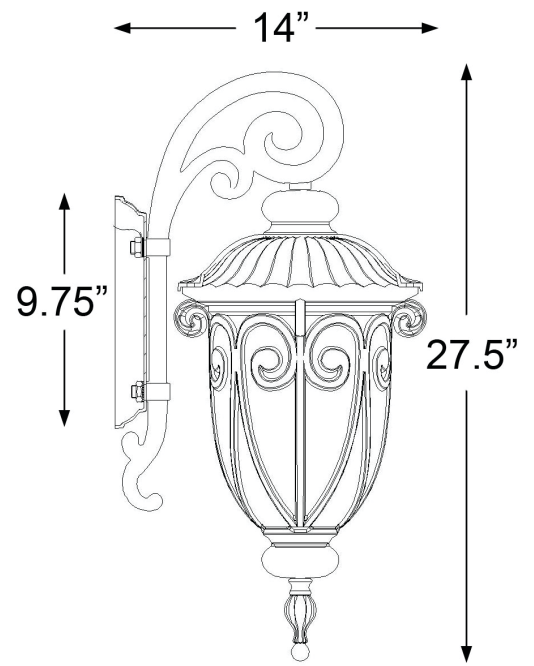
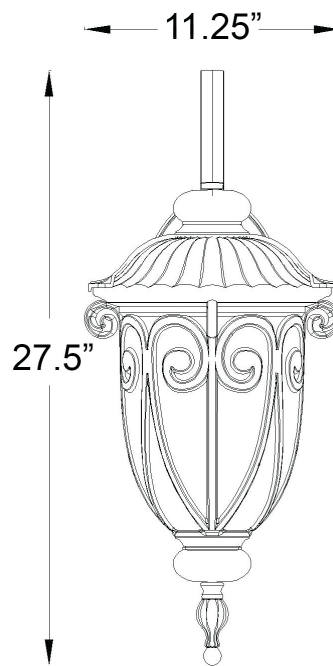

Description:	Naples 3-light wall lantern
Finish:	Matte black
Dimensions:	11-1/4" W x 27-1/2" H x 14" ext. Height on center: 11-1/2"
Bulbs:	3-60w cand.
Installed Weight:	11 lbs.
Certification:	Wet location

Material:	Cast aluminum
Shade:	Glass
Glass:	Clear seeded
Back Plate Dimensions:	6" x 9-3/4"
Chain/Wire:	NA
Additional Finishes:	Marbleized mahogany