

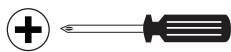

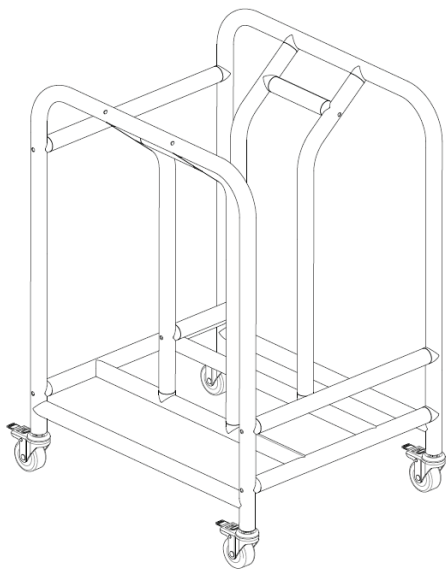

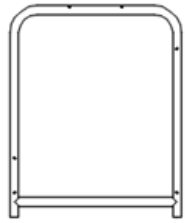





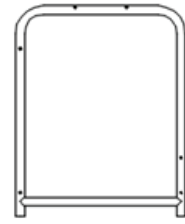
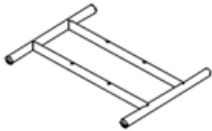

San Diego, CA 92117
www.ecr4kids.com

10 Piece Surf Storage Rack ELR-15832



A  1x	D  3x	G  2x	J  4x
B  1x	E  1x	H  22x	K  4x
C  2x	F  2x	I  22x	L  1x

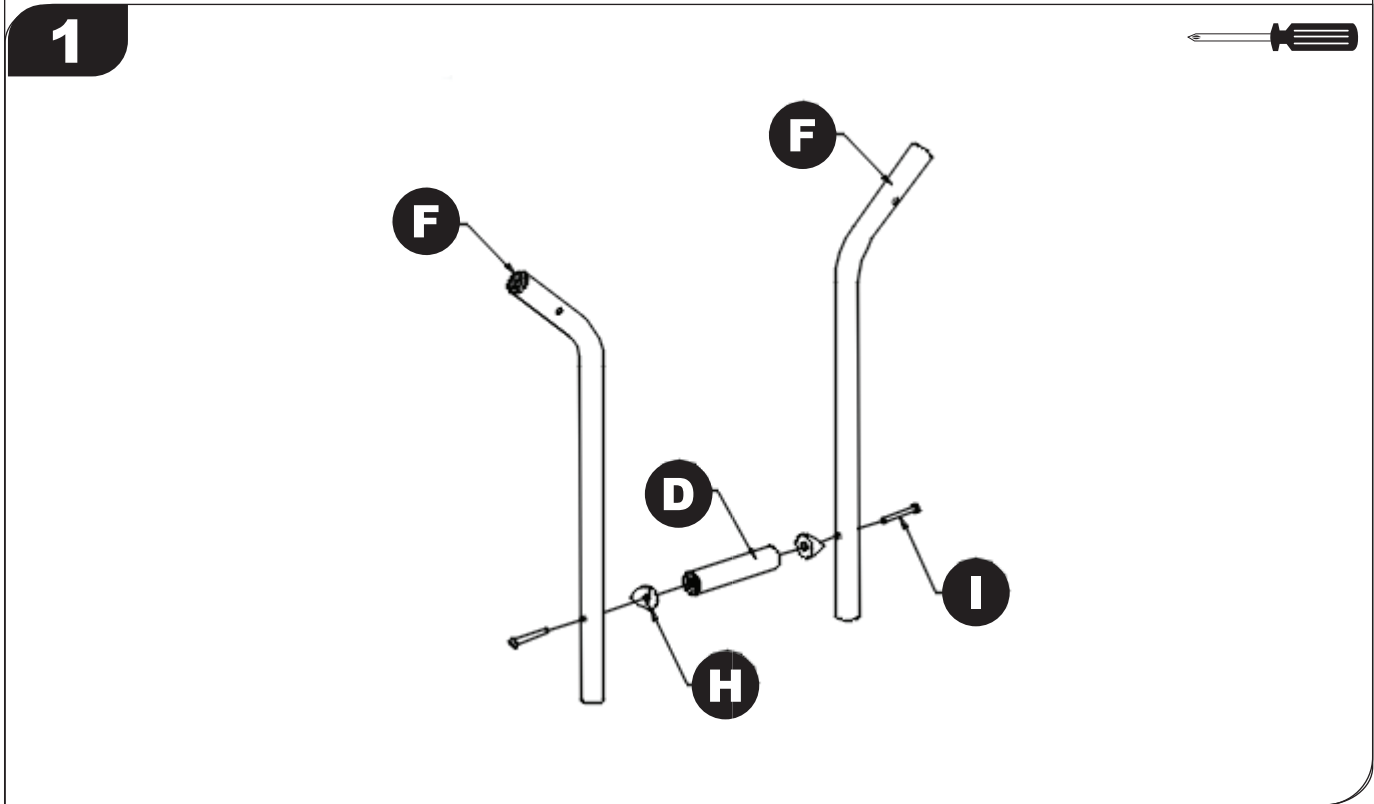

2

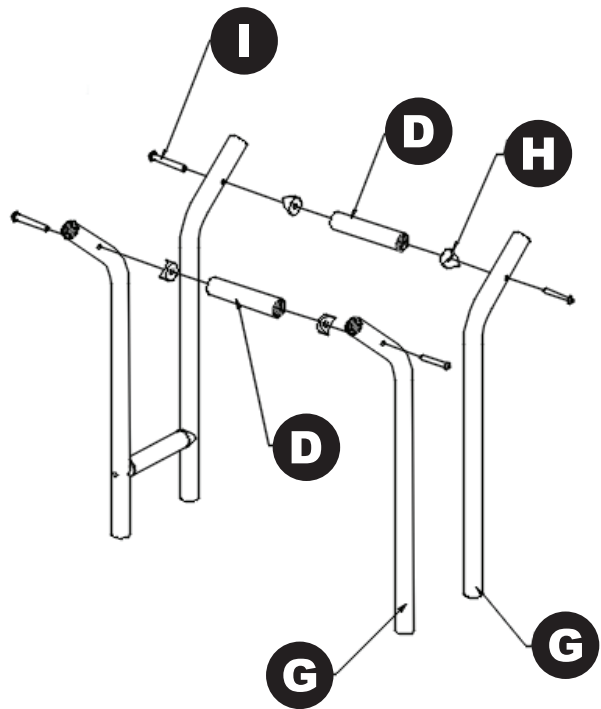

4

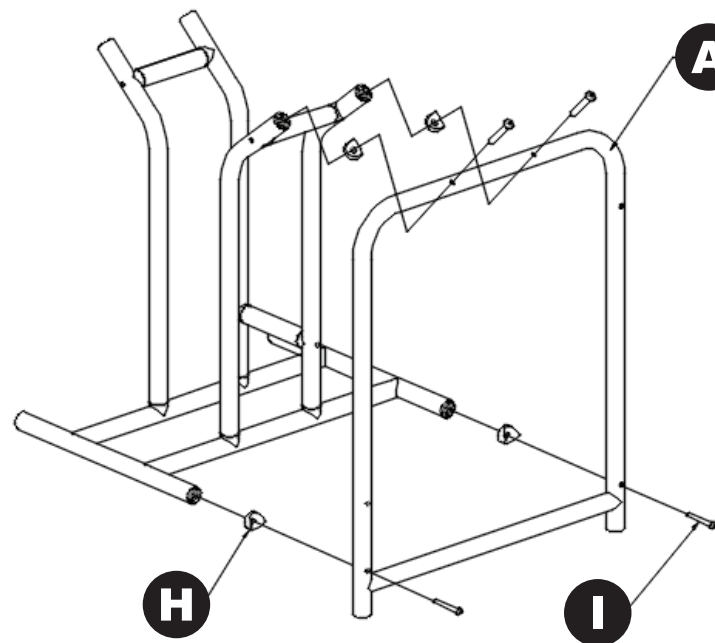

3

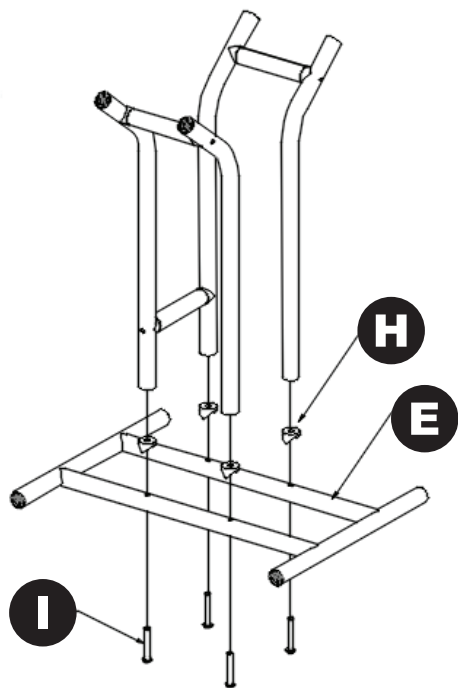

5

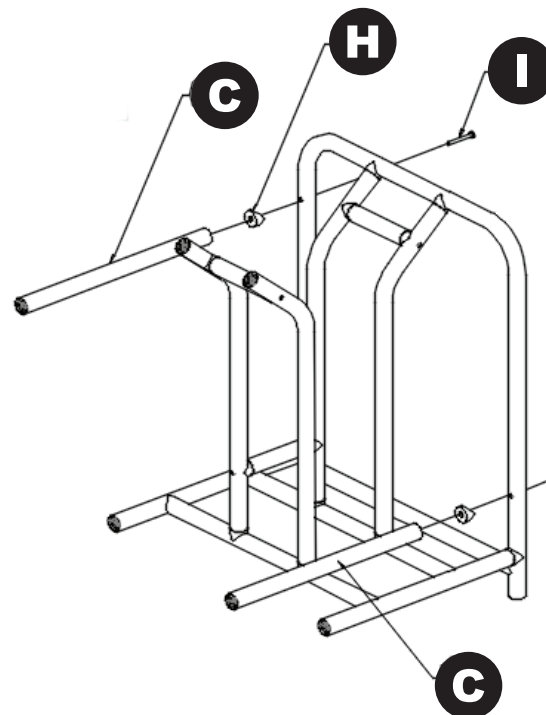

6

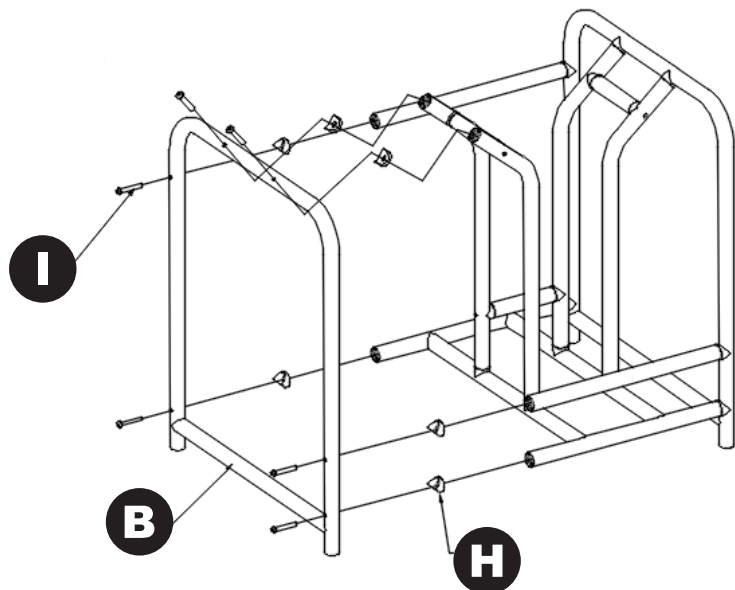

7

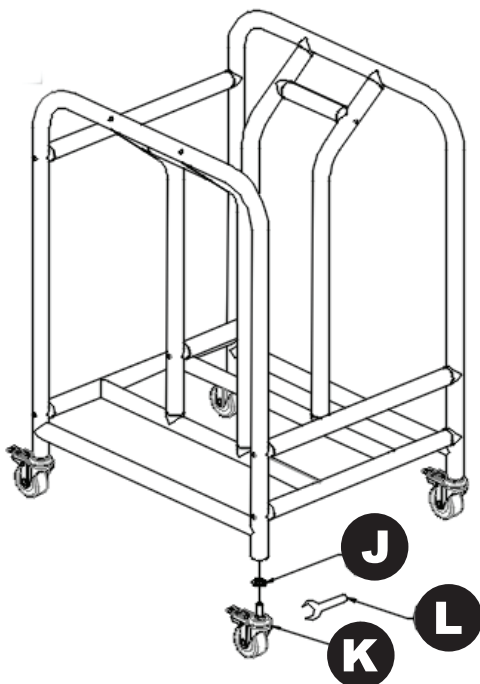

▲ WARNING:

Adult Assembly Required.

Two adults recommended.

- ▲ Contains small parts, sharp points and edges.
- ▲ Do not stand, sit, kneel, climb, lean or pull on unit for support.
- ▲ Never leave children unattended.
- ▲ Do not place unit near high heat or moisture.
- ▲ Adult supervision recommended.

▲ AVERTISSEMENT :

L'assemblage nécessite un adulte.

Deux adultes recommandés.

- ▲ Contient des petites pièces, des parties pointues et des bords tranchants.
- ▲ Ne pas se mettre debout, s'asseoir, s'agenouiller, monter, s'appuyer ou pousser sur l'unité pour se soutenir.
- ▲ Ne jamais laisser les enfants sans surveillance.
- ▲ Ne pas installer l'unité à côté d'une source de chaleur ou d'humidité.
- ▲ La surveillance par un adulte est recommandée.

▲ AVVERTENZA:

Il montaggio deve essere effettuato da persone adulte.

Si consiglia che venga effettuato da due adulti.

- ▲ Contiene componenti di piccole dimensioni, punti e bordi affilati.
- ▲ Non stare in piedi, sedersi, inginocchiarsi, arrampicarsi appoggiarsi sul gruppo di supporto oppure tirarlo.
- ▲ Non lasciare mai i bambini incustoditi.
- ▲ Non collocare l'unità vicino a fonti di calore elevato o umidità.
- ▲ È consigliata la supervisione di un adulto.

▲ ADVERTENCIA:

Se requiere un adulto para su ensamblaje.

Se recomienda que lo hagan dos adultos.

- ▲ Contiene partes pequeñas, puntas y bordes filosos.
- ▲ No se pare, siente, arrodille, trepe, recline o jale la unidad como apoyo.
- ▲ Nunca deje a los niños sin atención.
- ▲ No coloque la unidad cerca de donde haya calor o humedad.
- ▲ Se recomienda que lo supervise un adulto.

▲ WARNUNG:

Montage durch Erwachsene erforderlich.

Es werden hierfür zwei Erwachsene empfohlen.

- ▲ Enthält Kleinteile, scharfe Ecken und Kanten.
- ▲ Stehen, sitzen, knien, klettern, lehnen oder ziehen Sie nicht am Gerät, um sich zu behelfen.
- ▲ Lassen Sie Kinder niemals unbeaufsichtigt.
- ▲ Platzieren Sie das Gerät nicht in einer Umgebung an der hohe Hitze oder Feuchtigkeit herrschen.
- ▲ Eine Aufsicht durch Erwachsene wird empfohlen.

▲ 警告：

大人が組み立てるようにしてください。大人二人で作業することを推奨します。

- ▲ 小さい部品、鋭利な先端、刃先が含まれます。
- ▲ キャビネットを支えに上に立ったり、座ったり、ひざまずいたりしないでください。また、もたれかかったり、引っ張ったりしないでください。
- ▲ 子供だけで使用しないでください。
- ▲ キャビネットは高温、多湿の場所に設置しないでください。
- ▲ 大人による監督の下使用することを推奨します。