

**AXOR Starck**  
**Pressure Balance Trim**  
Finishes : **brushed nickel**    Part no. : **10407821**



## Description

### Features

- Flow: 5.44 GPM (20.6 L/Min)
- Integrated bypass for use with diverter tub spouts
- Temperature and on/off control for 1 outlet

## Product image



## Scale drawing

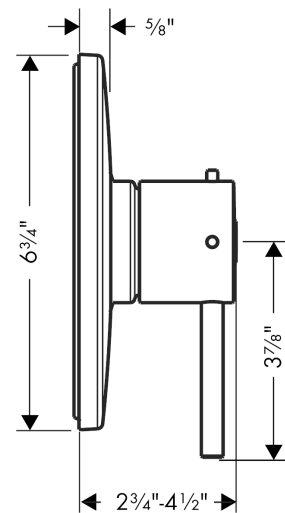

**AXOR Starck**  
**Pressure Balance Trim**  
Finishes : **brushed nickel**    Part no. : **10407821**



## Exploded drawing

Year of production: >07/09

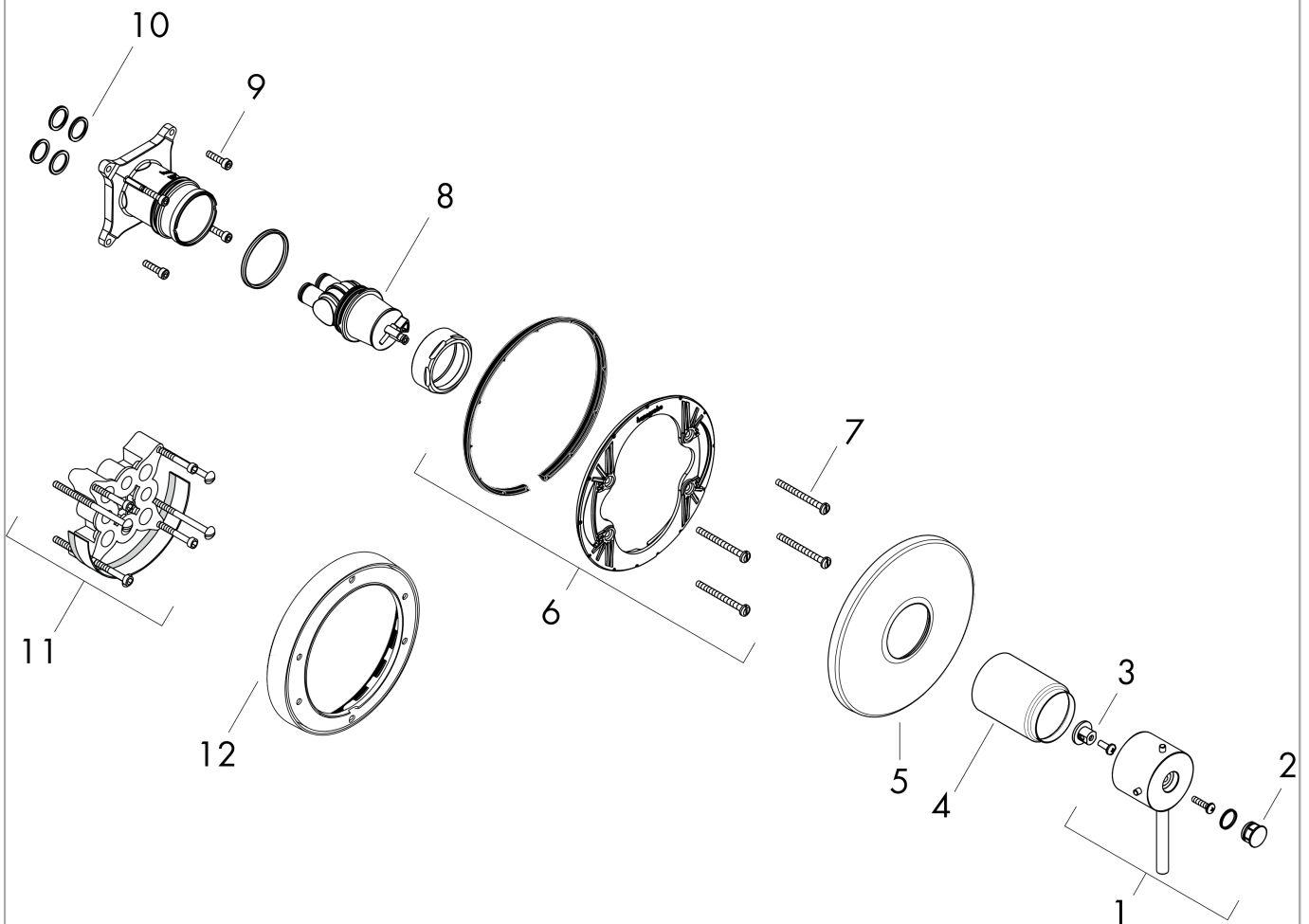

**AXOR Starck**  
**Pressure Balance Trim**  
 Finishes : **brushed nickel**    Part no. : **10407821**



## Spare parts list

Year of production: >07/09

Pos.	Description	Part no.	PC	PU
1	handle	88778820	0	1
2	screw cover	96540821	0	1
3	adapter for handle	92756000	0	1
4	sleeve	88765820	0	1
5	escutcheon	88760820	0	1
6	sub plate	96447000	0	1
7	set of fixing screws	96454000	0	1
8	cartridge, assy	88727000	0	1
9	set of screws	96525000	0	1
10	O-ring 16x2	98133000	0	1
11	extension 22 mm (Ø 170 mm)	13596820	0	1
12	extension 25 mm	13595000	0	1
a	base body	01850181	0	1