

SIDES	BOTTOM
4 3/4" KNOCKOUTS	2 1/2" KNOCKOUTS
4 1" KNOCKOUTS	2 3/4" KNOCKOUTS
	1 Ground Hump
2 PCS #8-32×1/2 Screws Installed	
Material: Steel-0.0625"-G60 Galvanized	

12 PLACES SPOT WELDING

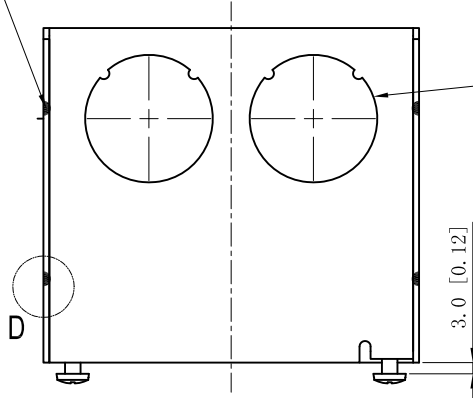

4 1" KNOCKOUT $\phi = 35.00$ ($\phi = 1.378$)

#8-32 UNC, ×2

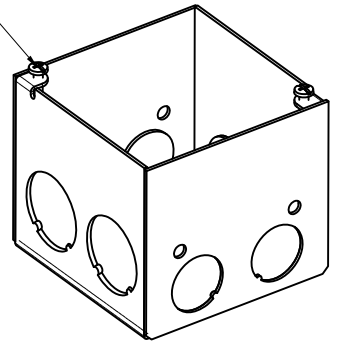

4 3/4" KNOCKOUTS $\phi = 28.50$ [$\phi = 1.122$] MORROR

2 3/4" KNOCKOUTS $\phi = 28.50$ [$\phi = 1.122$]

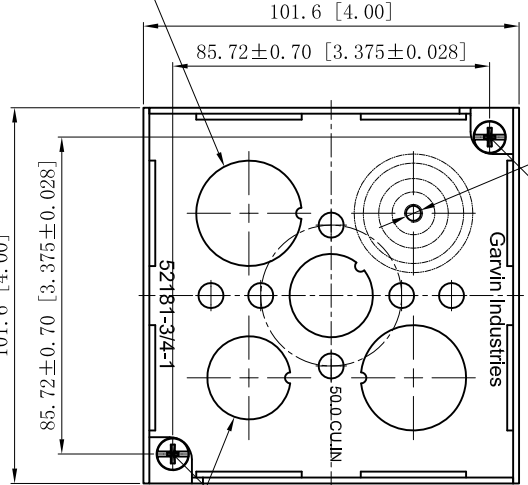
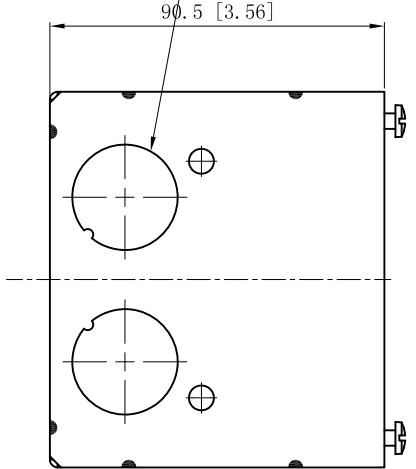

#10-32 UNF

2 1/2" KNOCKOUTS $\phi = 22.5$ [$\phi = 0.89$]

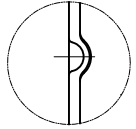

WELDING STYLE DETAIL VIEW D

This data sheet is for reference only .GARVIN INDUSTRIES reserves the right to make changes to the design without prior notice.

DESCRIPTION
TRADE REFERENCE TERMS

STANDARD PACKING
10 PCS

GARVIN INDUSTRIES		
TITLE 4" SQUARE BOXES 3-1/2" DEEP		
SIZE A4	DWG NO. 52181-3/4-1	REV
DATA SHEET		