

# JACK & JUNE

CIRCULAR REDWOOD PICNIC TABLE  
PG-PIC-CIR-RW

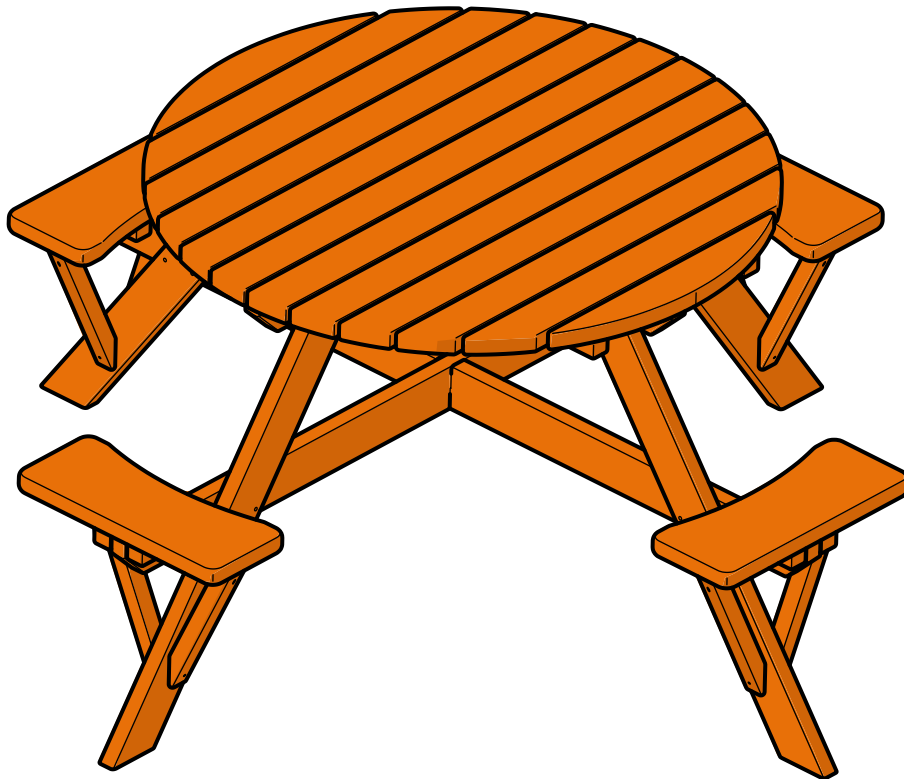

## ASSEMBLY INSTRUCTIONS

**Assembly requires 1 adult  
(approx. 30 minutes assembly time)**

Warning! Choke Hazard - not suitable for children  
under 36 months until fully assembled

**2L-7995-00**

## Advisory Section

To ensure the safety of you, the installer and your children, it is important that these instructions are read fully before commencing the positioning and assembly of this product. Assemble table on a clean flat area.

Assembly to be carried out by a competent adult only.

During assembly children should be kept away from the product due to possible risk of injury.

Do not use this item if any components are missing or damaged.

The maximum weight or load for which the product is suitable is 250lbs for each seat.

**NOTE:** Never stand or sit on the tabletop. Sit only on the seat, one person per seat.

## Timber Advice

This product has been made from premium timber. Great care has been taken in selecting, and machining the timber before it is presented to you. Timber is a natural product and as such may experience changes throughout the course of its life. This means it may:

- Develop openings (gaps, slits, apertures, cracks, splits) along the line of the grain. These openings are due to the difference in moisture content between the internal and outer surfaces of the timber. This is to be expected, is totally acceptable and will not affect the integral strength, life or guarantee of the product.
- Warp and distort its shape. Any distortion will be slight and will not affect the safety or enjoyment of this product.
- Fade as the timber reacts with sunlight. The timber should be treated with a proprietary product to act as a protective barrier, i.e. a water repellent, upon completion of assembly and on an annual basis.
- Upon completion of assembly and after the first year of service, treat product with a good quality treatment/wood preservative safe for children's use.

## Routine Maintenance

It is advised that on a regular basis (i.e. at the beginning of the season and monthly thereafter) all main parts/ fixings are checked as secure, have no sharp points/edges and are intact. Replace, and/or tighten when necessary. Failure to do so may result in an injury or hazard.

Important: Retain these instructions for future reference

# STANDARD PARTS LIST

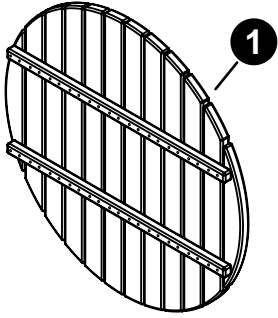

Picnic Table Top  
JJ-PIC-ROUND-TOP-RW  
QTY. 1

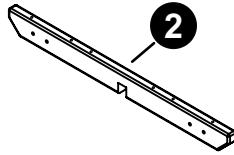

2X4 TABLE BRACE  
PG-24-0105  
QTY. 1

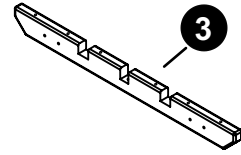

2X4 TABLE BRACE 2  
PG-24-0106  
QTY.1

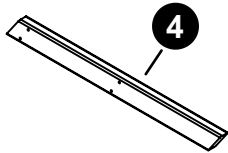

2x4 Table Leg  
PG-24-0107  
QTY. 4

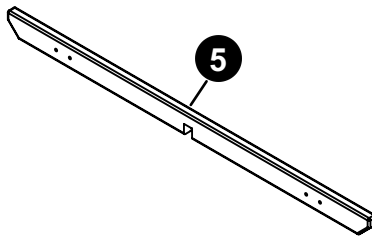

2x4 Bottom Brace  
PG-24-0108  
QTY. 1

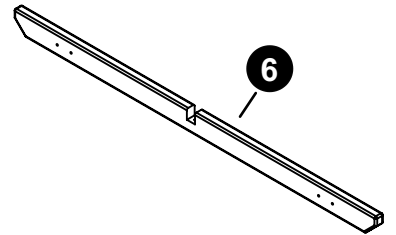

2X4 BOTTOM BRACE 2  
PG-24-0109  
QTY. 1

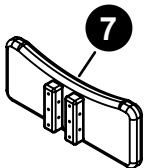
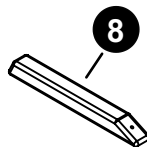
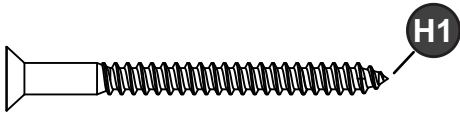

Table Seat Assembly  
JJ-PIC-ROUND-SEAT-RW  
QTY. 4



2x2 Seat Support Brace  
PG-22-0005  
QTY. 8

# HARDWARE



M4 X 50MM PHILLIPS FLAT HEAD SCREW  
QTY. **32**

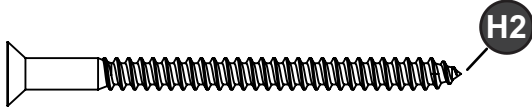

M4 X 60MM PHILLIPS FLAT HEAD SCREW  
QTY. **2**

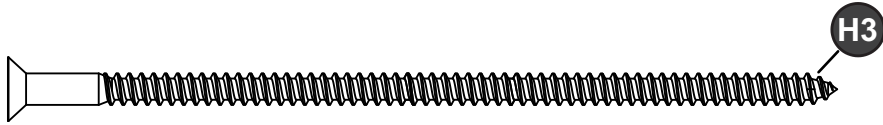

M4 X 110MM PHILLIPS FLAT HEAD SCREW  
QTY. **12**

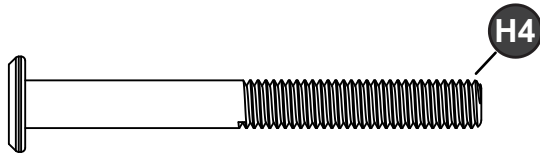

ALLEN BOLT M6X60MM  
QTY. **16**

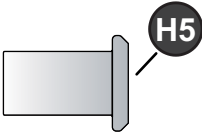

M6X15MM ALLEN NUT  
QTY. **16**

# TOOLS NEEDED



PHILLIPS SCREW DRIVER

**NOTE:**

An electric screwdriver is helpful in assembly. However, please set at low torque and use extreme caution with an electric screwdriver because you could over-tighten the hardware & strip out the screws.



ALLEN KEY (Included)

## HARDWARE NEEDED (ACTUAL SIZE)

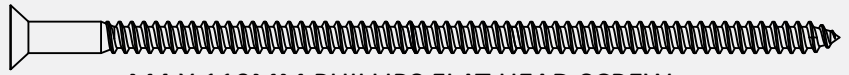

H3

M4 X 110MM PHILLIPS FLAT HEAD SCREW

QTY. 6

**NOTE:** Place the Table top assembly (#1) on a clean flat surface before starting the assembly process.

### STEP 1

Assemble Table Brace (#2) to Table Top Assembly (#1) to using H3 Screws as shown . Make sure Table Brace is **Centered** on Table Top Assembly. See illustrations below.

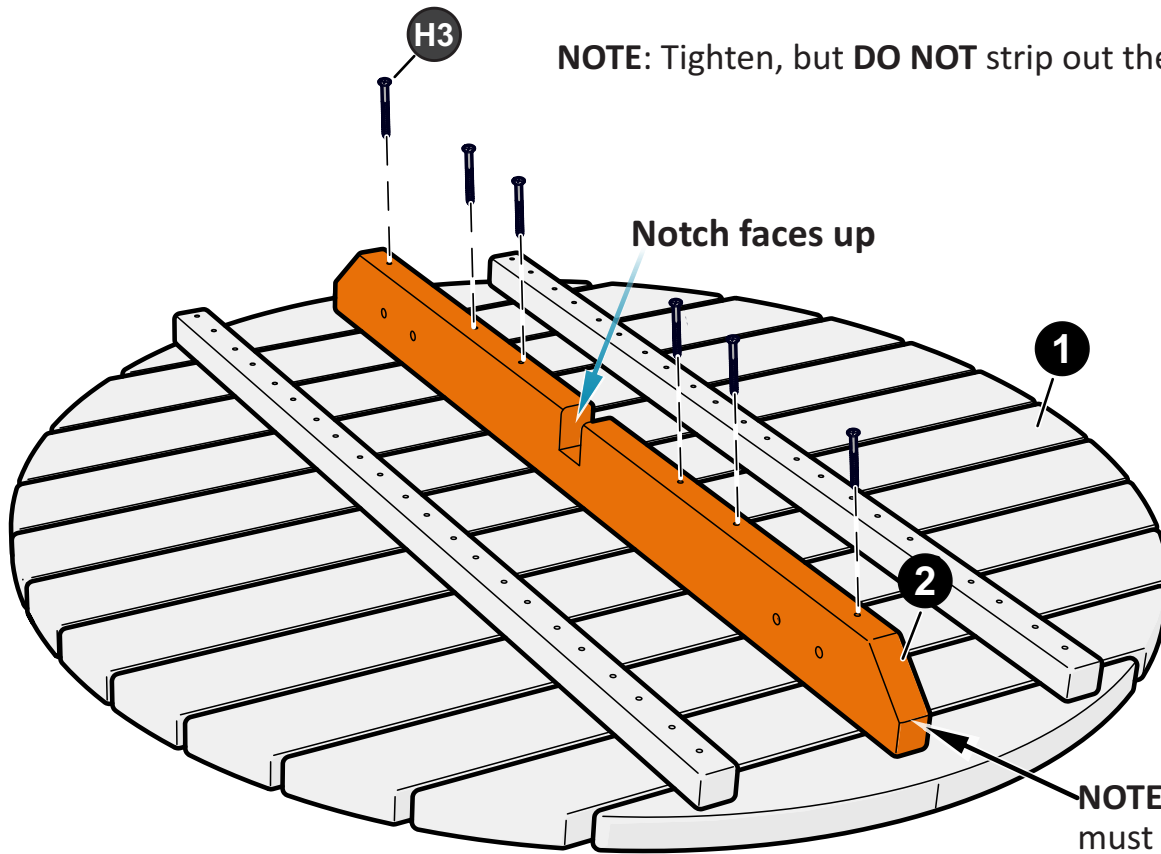

**NOTE:** Tighten, but **DO NOT** strip out the H3 screws.

**NOTE:** All H3 screws must be **centered** on Table Brace (#2).

### SIDE VIEW

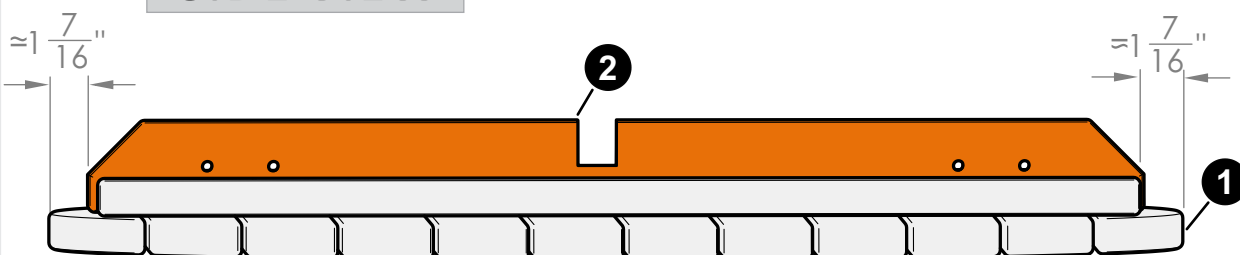

## STEP 2

Attach Table Brace (#3) to Table Brace (#2) from Step 1 assembly. Use a H2 Screw in the center, then the H3 screws for the remaining holes. See illustrations below.

### HARDWARE NEEDED (ACTUAL SIZE)



M4 X 110MM PHILLIPS FLAT HEAD SCREW  
QTY. 6

H3



M4 X 60MM PHILLIPS FLAT HEAD SCREW  
QTY. 1

H2

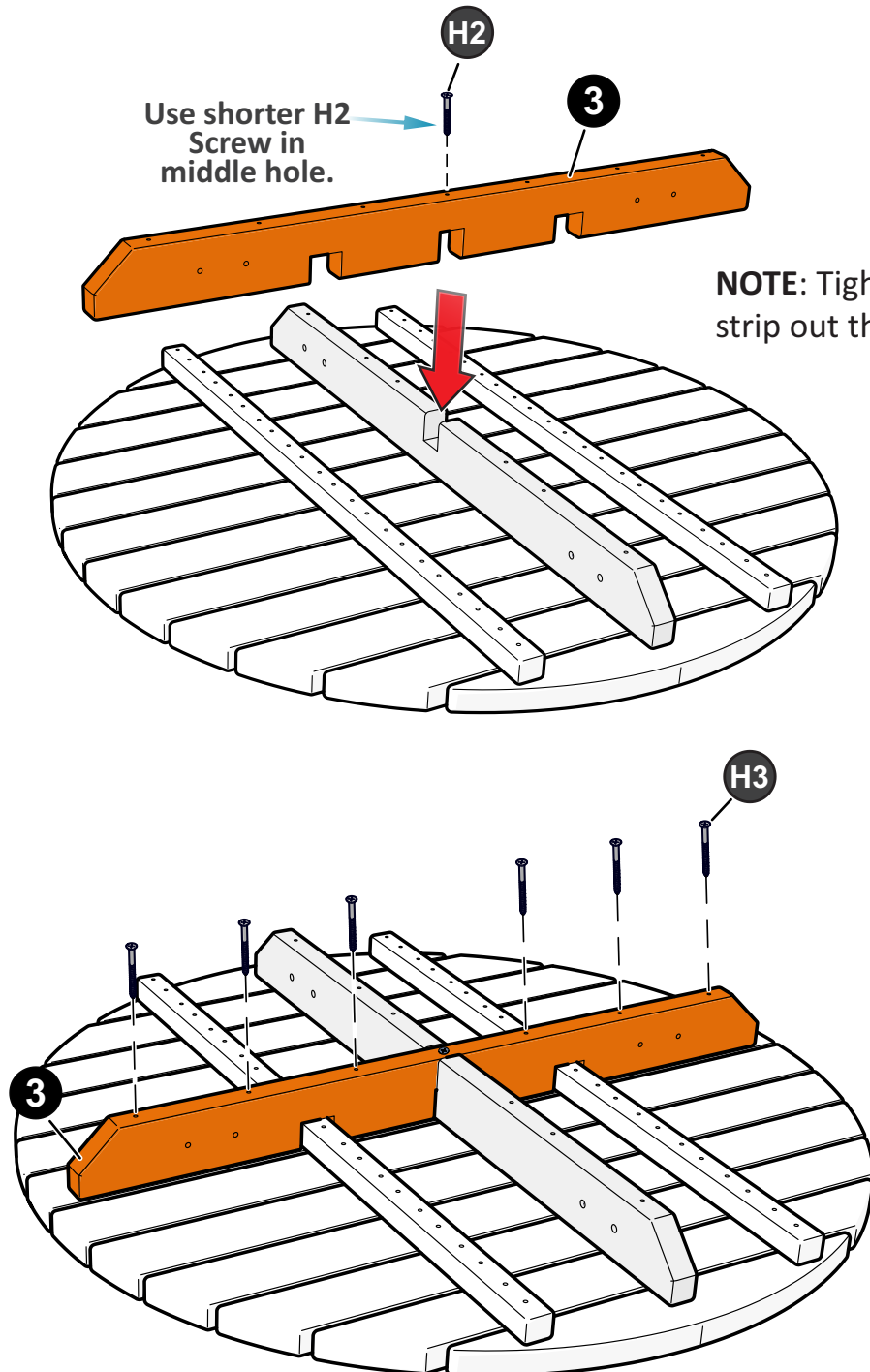

Use shorter H2  
Screw in  
middle hole.

**NOTE:** Tighten, but **DO NOT**  
strip out the screws.

## STEP 3

Attach two Base Legs (#4) using H4 & H5 hardware as shown. Use provided Allen key to tighten.

### HARDWARE NEEDED (ACTUAL SIZE)

H4

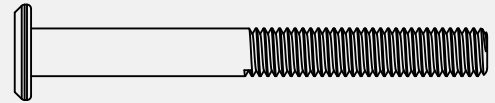

M6X60MM ALLEN BOLT  
QTY. 4

H5

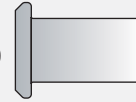

M6x15MM ALLEN NUT  
QTY. 4

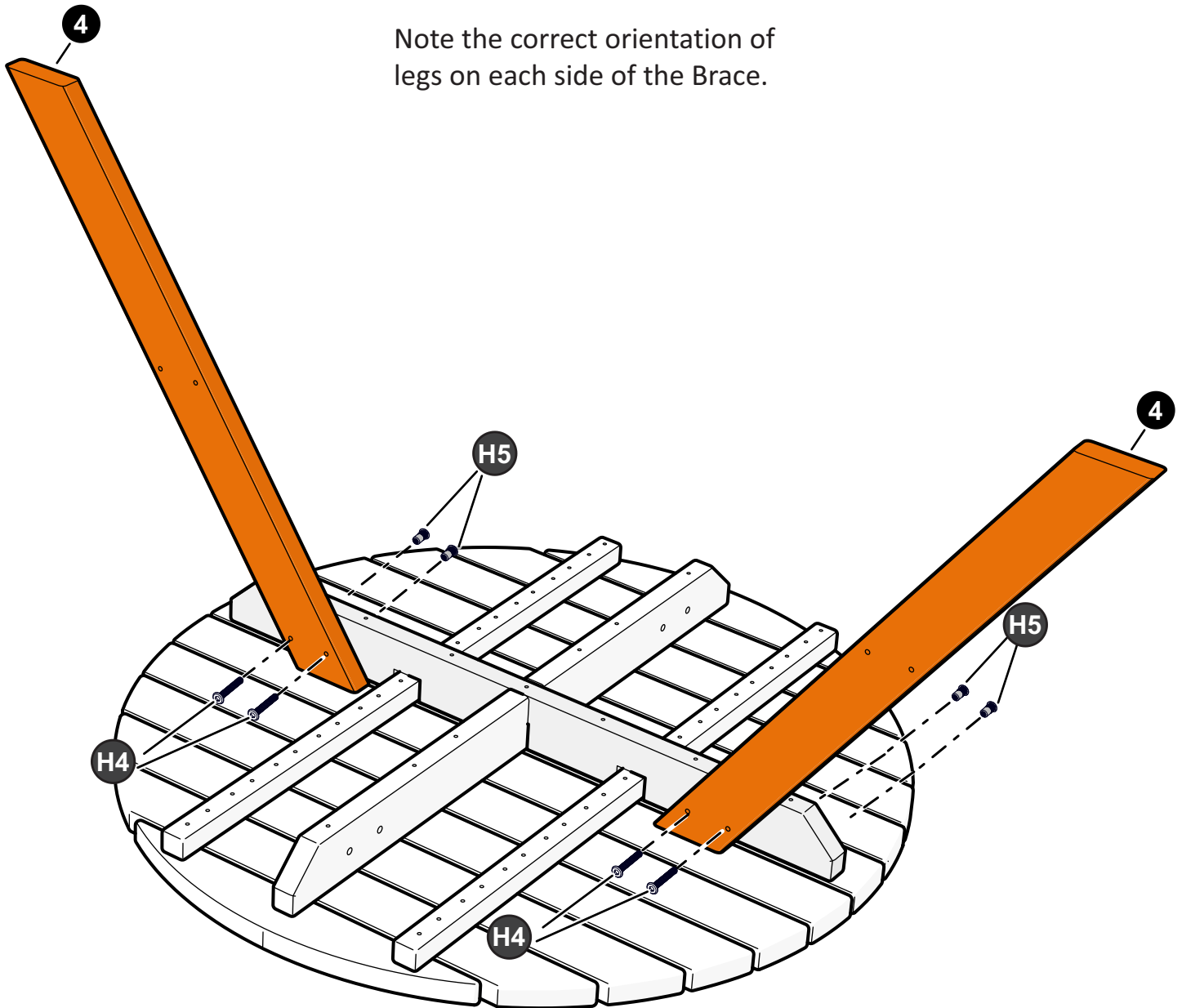

Note the correct orientation of legs on each side of the Base.

## STEP 4

Attach two Base Legs (#4) using H4 & H5 hardware as shown. Use provided Allen key to tighten.

### HARDWARE NEEDED (ACTUAL SIZE)

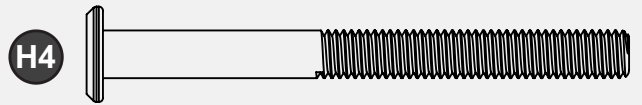

M6X60MM ALLEN BOLT  
QTY. 4

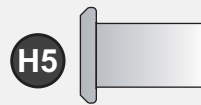

M6x15MM ALLEN NUT  
QTY. 4

Note the correct orientation of legs on each side of the Brace.

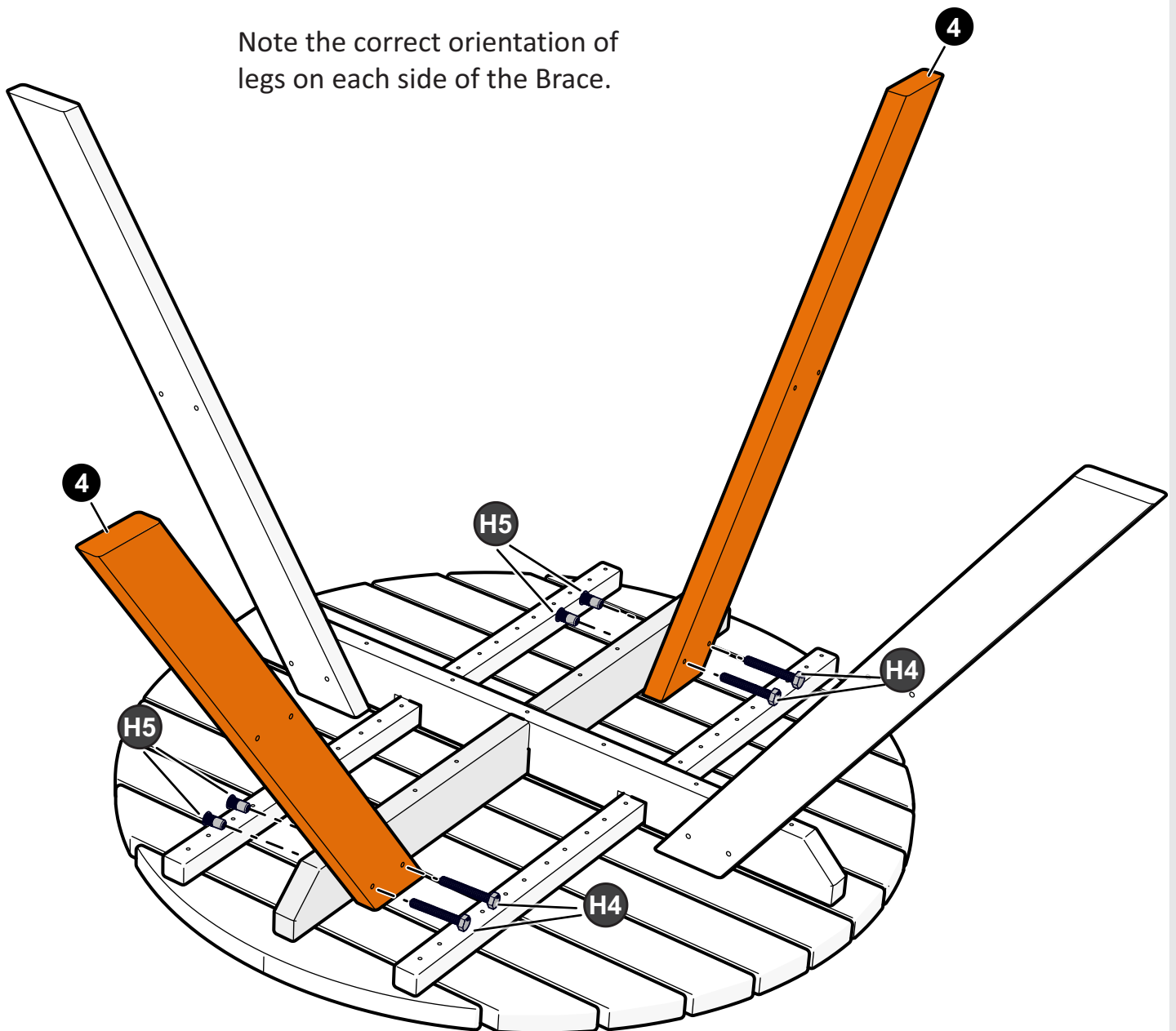



## STEP 5

Attach Cross Beam (#5) using hardware H4 & H5 as shown.

**NOTE:** Place Crossbeams to the right of Base Legs as shown. Use provided Allen key to tighten H4 Bolts & H5 Nuts.

### HARDWARE NEEDED (ACTUAL SIZE)

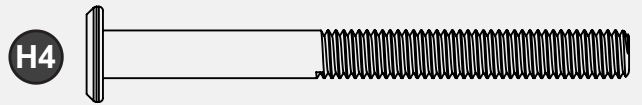

M6X60MM ALLEN BOLT  
QTY. 4



M6x15MM ALLEN NUT  
QTY. 4

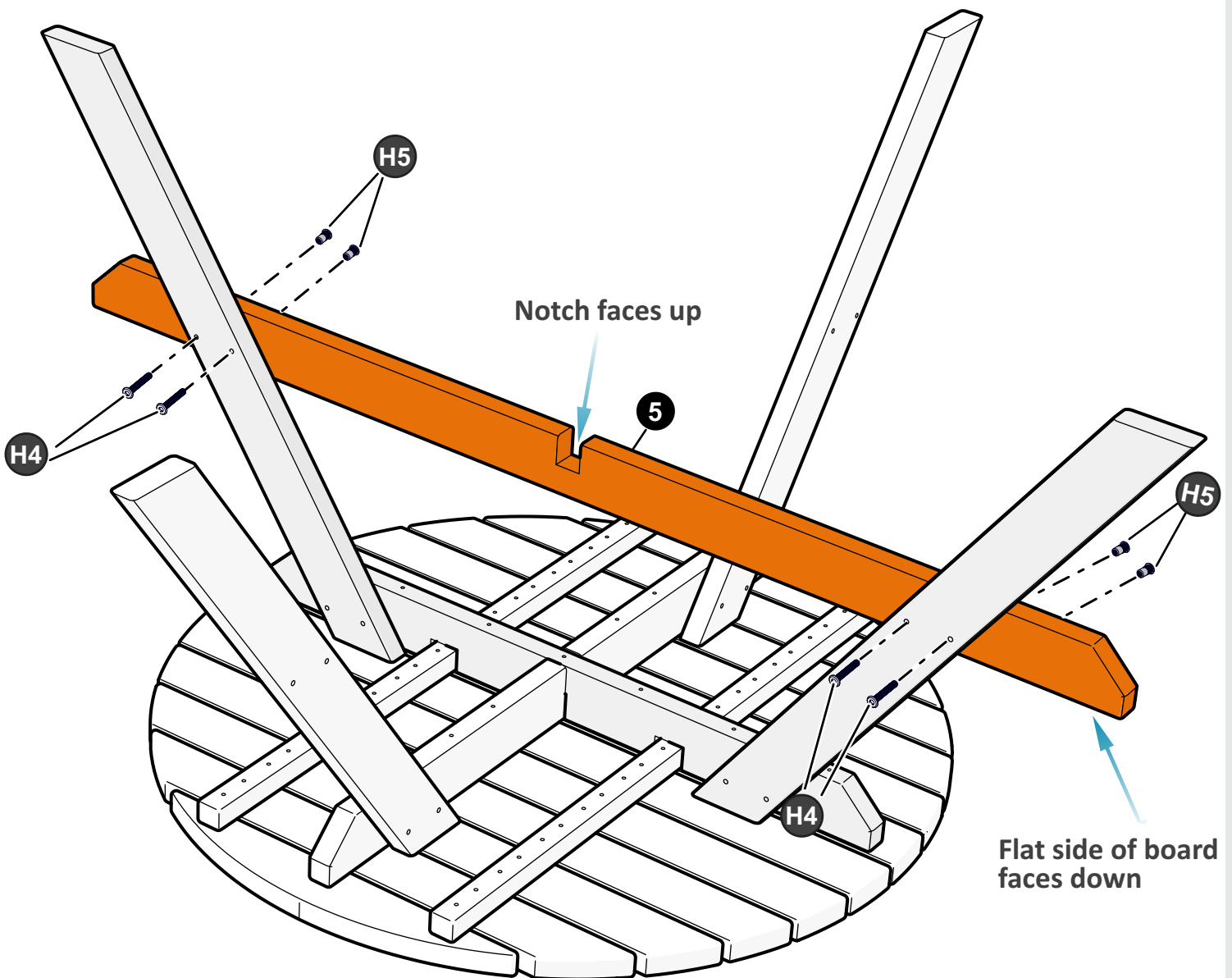

## STEP 6

Attach Cross Beam (#6) using hardware H2, H4 & H5 as shown.

**NOTE:** Place Crossbeams as shown. Install H2 screw as shown in diagram. Use provided Allen key to tighten ALL H4 Bolts & H5 Nuts.

### HARDWARE NEEDED (ACTUAL SIZE)

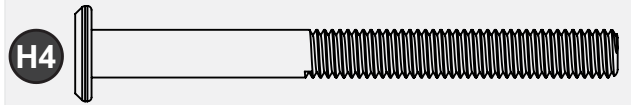

M6X60MM ALLEN BOLT  
QTY. 4

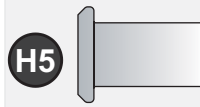

M6x15MM ALLEN NUT  
QTY. 4



M4 X 60MM WOOD SCREW  
QTY. 1

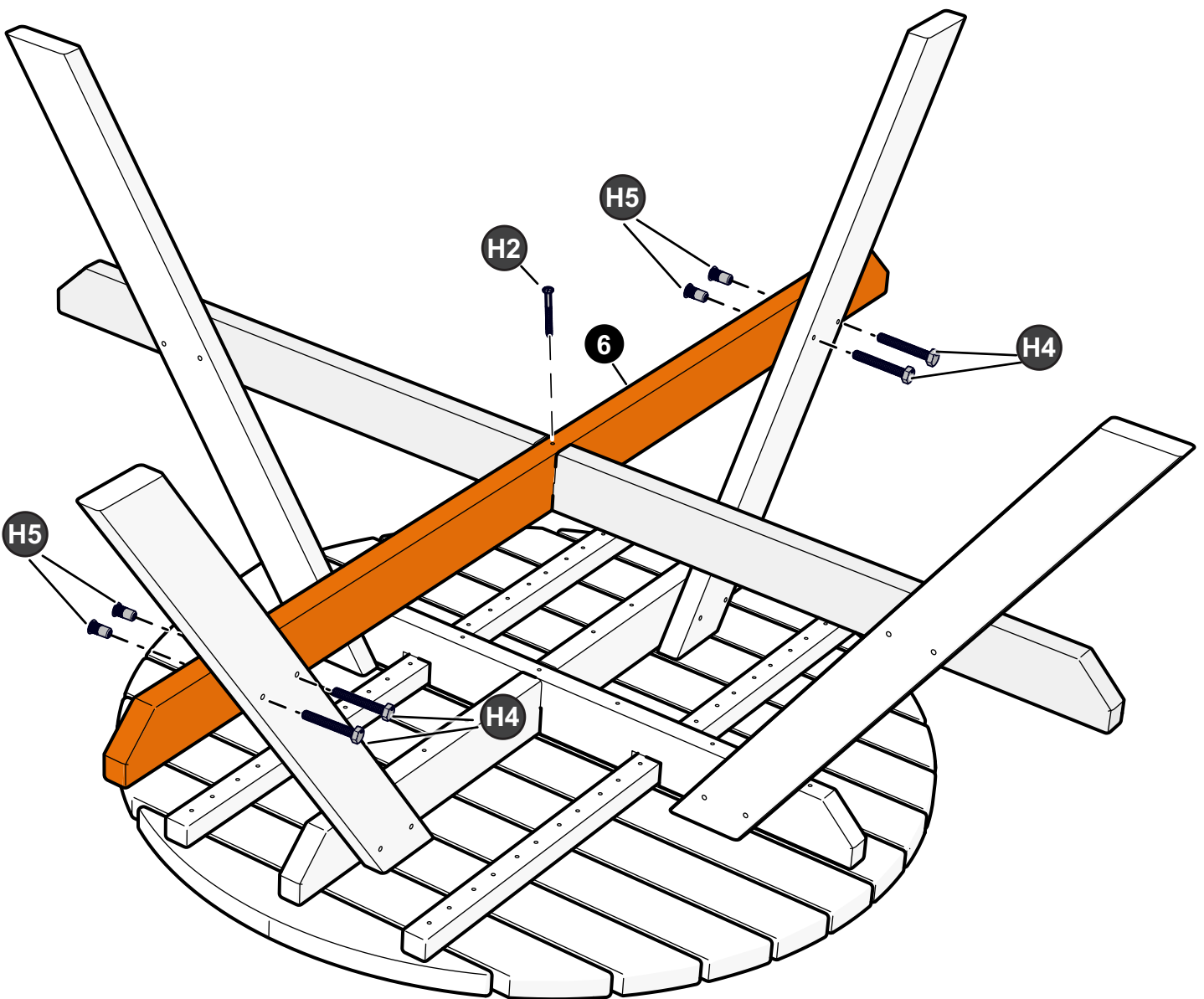

## STEP 7

Attach Seat Assemblies (#7) using H1 screws as shown in the picture below and on the **Side View**.

**NOTE:** Tighten, but **DO NOT** strip out H1 screws.

### HARDWARE NEEDED (ACTUAL SIZE)



M4 X 50MM WOOD SCREW  
QTY. 16

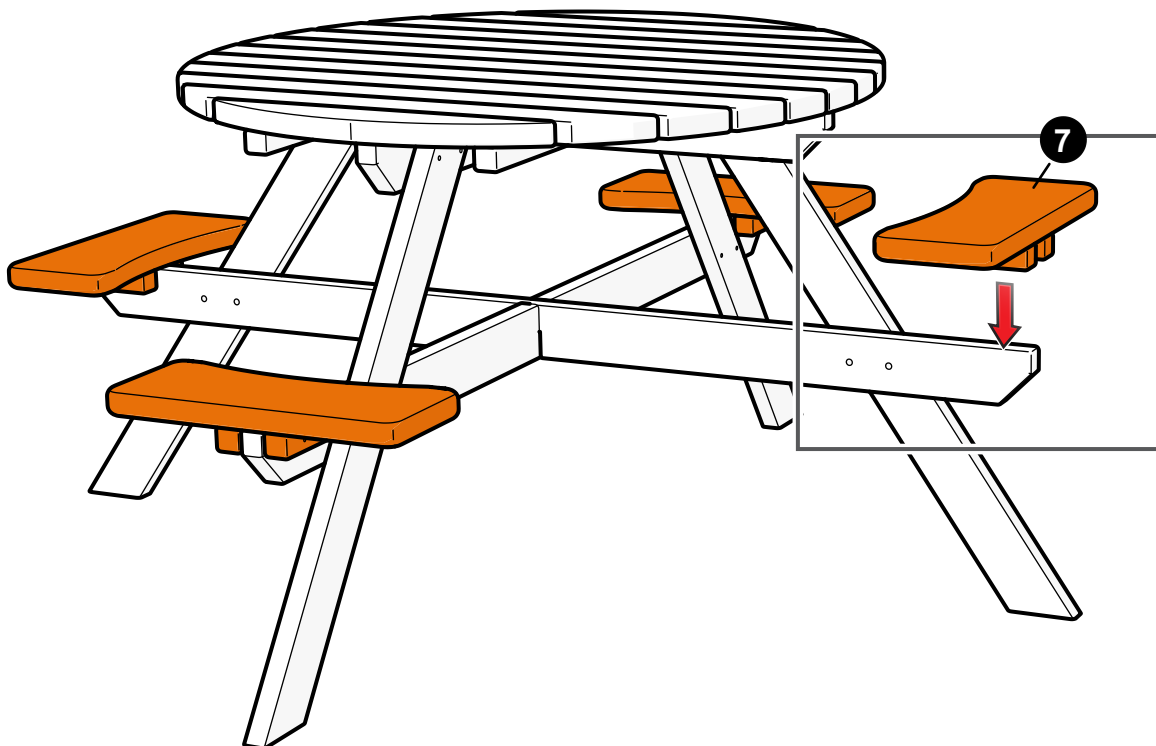

### SIDE VIEW

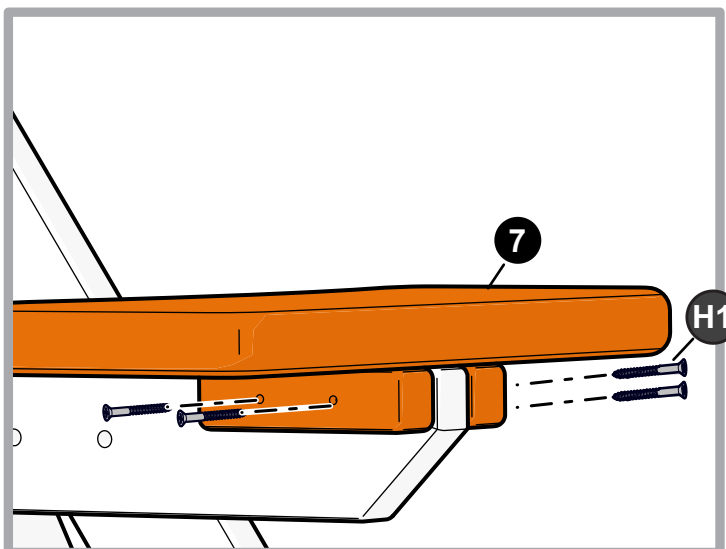
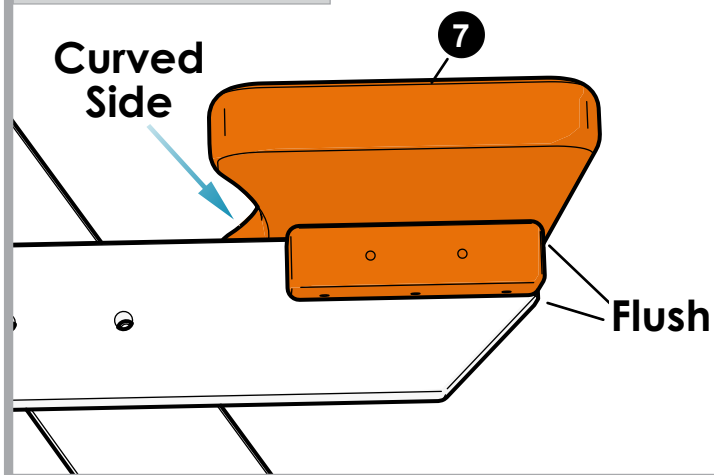

## STEP 8

Attach Seat Support Brace (#8) to each Seat Assembly as shown in the **Side View** below.

### HARDWARE NEEDED (ACTUAL SIZE)



M4 X 50MM WOOD SCREW  
QTY. 16

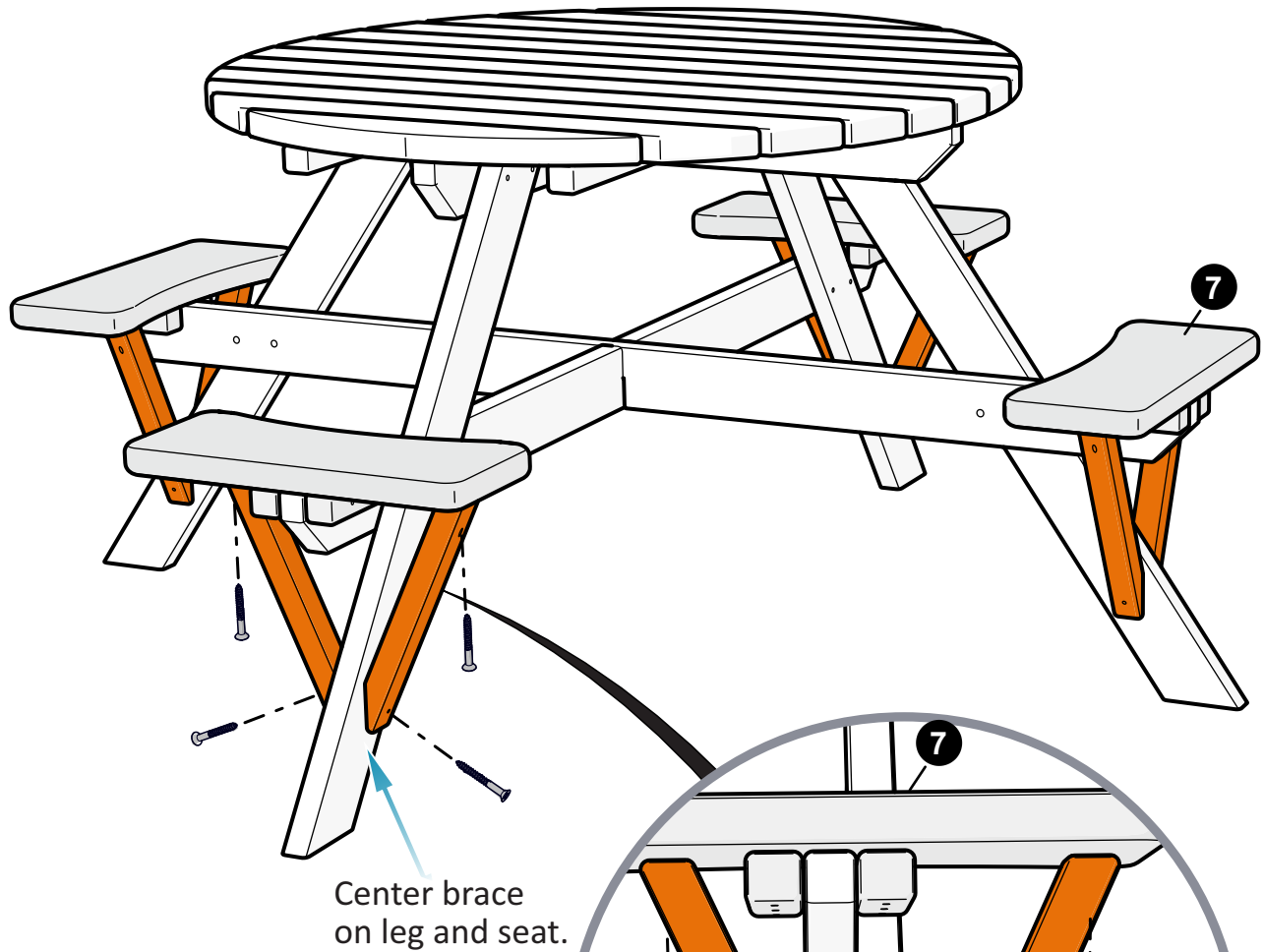

### FRONT VIEW

**NOTE:** Tighten the **H1** screws, but be careful not to split the (**#8**) Seat Support Braces. Should the brace split, re-enforce with wood glue.

# JACK & JUNE WARRANTY

## **90 Day Warranty**

Subject to proper installation and normal residential use, Jack & June warrants, subject to the limitations stated below, to the original retail purchaser, parts to be free from defects in material and workmanship for a period of **90-days** from date of purchase. Merchandise covered under this limited **90-day** warranty will, at our option, be repaired or replaced, excluding any freight or labor fees.

For **90-days** after the original purchase date of our **products**, Jack & June warrants, to the original retail purchaser, all wooden components against structural failure due to corrosion, wood rot, or insect infestation. Seasonal checks, surface cracks, knotholes and knots, not resulting in structural failure, are natural characteristics of all wooden play equipment, are not covered under this warranty and will not affect the integrity of your playset.

Jack & June warrants to the original retail customer that we will replace any hardware that fail due to rust or breakage (excludes surface rust).

Timber is a natural material which can absorb and release moisture. Although this product is designed to minimize this effect, in certain circumstances some movement or distortion is unavoidable. During dry hot weather timber may shrink and check - this is a normal process of weathering. After the first year of service it is advisable to clean and apply a non-toxic stain or sealant to the wood, safe for children's use.

Components covered under this **90 Day** warranty will be replaced free of charge excluding freight and labor fees.

Non-residential use of the playset is prohibited and voids the warranty as the playsets are designed for residential use only.

Escalade Sports reserves the right to examine photographs and/or physical evidence of merchandise claimed to be defective, and to recover said merchandise, prior to disposition of warranty claims. Merchandise returned to our factory for examination or recovery must be shipped freight prepaid, unless a Return Authorization Number is issued.

This warranty program does not cover normal wear and tear, color fading, or damages resulting from misuse, abuse, vandalism, alteration, acts of God, or assembly and maintenance contrary to our instructions. Escalade Sports assumes no responsibility for incidental or consequential damages which may arise from the purchase or use of our equipment. Please supervise your children's play activity and maintain your play equipment periodically.

This warranty is expressly in lieu of all other warranties, expressed or implied, including warranties of merchantability or fitness for use. Jack & June does not assume or authorize any person to assume for us, any other liability in connection with the sale of our products.

Special Note: Jack & June reserves the right to make changes in materials, design, and pricing without notice. See your instruction manual for maintenance requirements. Your child's safety is your responsibility; therefore, you should inspect this equipment regularly for wear and safety.

**For warranty service, contact:**

**Escalade Sports**

**P.O. Box 889**

**Evansville, IN 47706**

**1-800-GO-SWING**

**Or E-Mail us at: [playgroundcs@escaladesports.com](mailto:playgroundcs@escaladesports.com)**