

# INSTRUCTION MANUAL

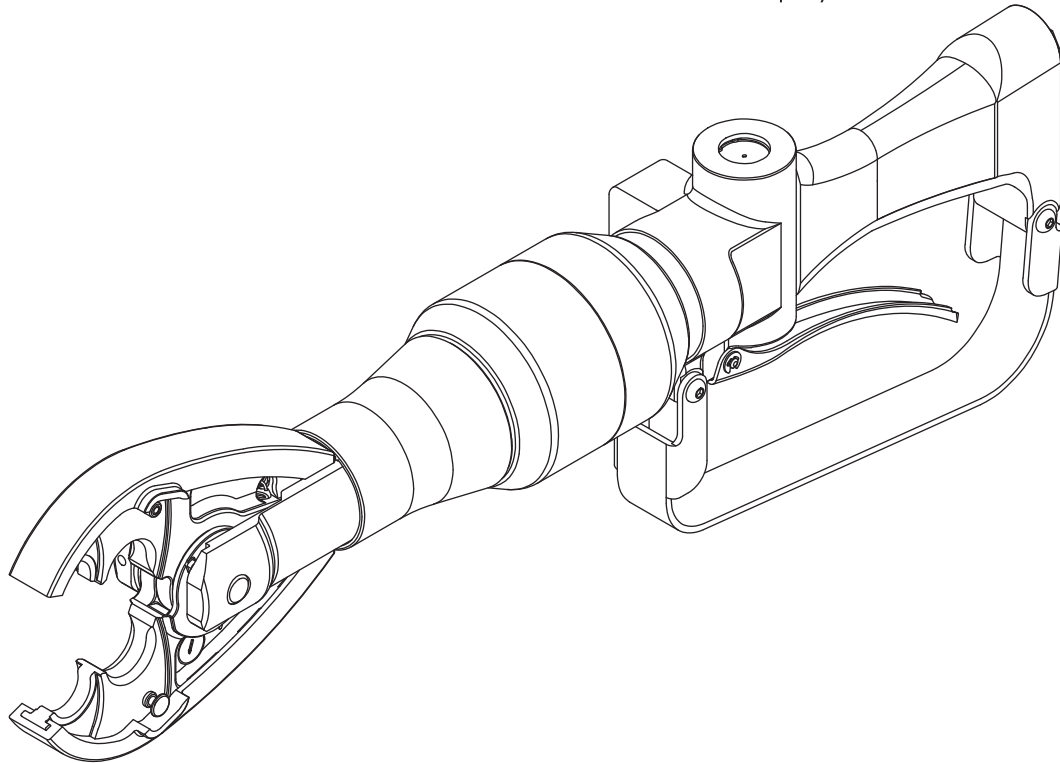

**GREENLEE**<sup>®</sup>  
**UTILITY**  
A Textron Company



## **LP6**

# **Hydraulic Crimping Tool**

Serial Codes GMA, GMB, GMD, and GME



**Read and understand** all of the instructions and safety information in this manual before operating or servicing this tool.

Register this product at [www.greenlee.com](http://www.greenlee.com)

## Table of Contents

Description .....	2
Safety .....	2
Purpose of this Manual .....	2
Other Publications .....	2
Important Safety Information .....	3-5
Identification .....	6
Specifications .....	7
Hoses and Fittings .....	8
Hose Connections .....	8
Typical Setup .....	8
Operation .....	9-10
Maintenance .....	11
Periodic Pressure Relief Valve Check .....	11
Troubleshooting .....	12
Illustrations and Parts Lists .....	13-16

## Description

The LP6 Hydraulic Crimping Tool is a hand-held crimping tool with removable crimping jaws that is intended to crimp connectors onto electrical cable.

This tool is factory set for operation on an open-center or closed-center hydraulic system.

## Safety

Safety is essential in the use and maintenance of Greenlee Utility tools and equipment. This manual and any markings on the tool provide information for avoiding hazards and unsafe practices related to the use of this tool. Observe all of the safety information provided.

## Purpose of this Manual

This manual is intended to familiarize all personnel with the safe operation and maintenance procedures for the following Greenlee Utility tools:

- LP6-01 Serial Code GMB
- LP6-02 Serial Code GMA
- LP6-03 Serial Code GMD
- LP6-04 Serial Code GME

Keep this manual available to all personnel.

Replacement manuals are available upon request at no charge at [www.greenlee.com](http://www.greenlee.com).

## Other Publications

### Tool Owners/Users

SAE Standard J1273 (Hose and Hose Assemblies):  
Publication 99930323

All specifications are nominal and may change as design improvements occur. Greenlee Textron Inc. shall not be liable for damages resulting from misapplication or misuse of its products.

# **KEEP THIS MANUAL**

## IMPORTANT SAFETY INFORMATION



### SAFETY ALERT SYMBOL

This symbol is used to call your attention to hazards or unsafe practices which could result in an injury or property damage. The signal word, defined below, indicates the severity of the hazard. The message after the signal word provides information for preventing or avoiding the hazard.

#### **⚠ DANGER**

Immediate hazards which, if not avoided, **WILL** result in severe injury or death.

#### **⚠ WARNING**

Hazards which, if not avoided, **COULD** result in severe injury or death.

#### **⚠ CAUTION**

Hazards or unsafe practices which, if not avoided, **MAY** result in injury or property damage.



#### **⚠ WARNING**

**Electric shock hazard:**  
This tool is not insulated. When using this unit near energized electrical lines, use only certified non-conductive hoses and proper personal protective equipment.  
Failure to observe this warning could result in severe injury or death.



#### **⚠ WARNING**

**Skin injection hazard:**

- Do not use hands to check for leaks.
- Do not hold hose or couplers while the hydraulic system is pressurized.
- Depressurize the hydraulic system before servicing.

Oil under pressure easily punctures skin, causing serious injury, gangrene, or death. If you are injured by escaping oil, seek medical attention immediately.



#### **⚠ WARNING**

Read and understand all of the instructions and safety information in this manual before operating or servicing this tool.  
Failure to observe this warning could result in severe injury or death.



#### **⚠ WARNING**

Wear eye protection when operating or servicing this tool.  
Failure to wear eye protection could result in serious eye injury from flying debris or hydraulic oil.



#### **⚠ WARNING**

Wear hearing protection when using this tool.  
Long-term exposure to high noise levels could result in hearing damage.

## IMPORTANT SAFETY INFORMATION

	<p><b>⚠ WARNING</b></p> <p>The hydraulic cylinder may be hot during and after operation. Hot surfaces can cause serious burns.</p>
---	--

<p><b>⚠ WARNING</b></p> <p>Do not disconnect tool, hoses, or fittings while the power source is running or if the hydraulic fluid is hot. Hot hydraulic fluid can cause serious burns.</p>
--

	<p><b>⚠ WARNING</b></p> <p>Keep hands away from the crimping tool head when crimping.</p> <p>Failure to observe this warning could result in severe injury or death.</p>
---	--

<p><b>⚠ WARNING</b></p> <p>Do not reverse hydraulic flow. Operation with hydraulic flow reversed can cause tool malfunction. Connect the pressure (supply) hose and tank (return) hose to the proper tool ports.</p> <p>Failure to observe this warning could result in severe injury or death.</p>
---

<p><b>⚠ WARNING</b></p> <p>An incomplete crimp can cause a fire.</p> <ul style="list-style-type: none"> <li>• Use proper die, connector, and cable combinations. Improper combinations can result in an incomplete crimp.</li> <li>• The relief valve sounds to indicate a completed crimp. If you do not hear the sound of the relief valve, the crimp is not complete.</li> </ul> <p>Failure to observe this warning could result in severe injury or death.</p>
--

<p><b>⚠ WARNING</b></p> <p>Do not change accessories, inspect, adjust, or clean tool when it is connected to a power source. Accidental start-up can result in serious injury.</p> <p>Failure to observe this warning could result in severe injury or death.</p>
---

<p><b>⚠ WARNING</b></p> <p>Do not exceed the following hydraulic power source maximums:</p> <ul style="list-style-type: none"> <li>• Hydraulic flow: 34.1 l/min (9 gpm).</li> <li>• Pressure relief setting: 172 bar (2500 psi).</li> <li>• Back pressure: 13.8 bar (200 psi)</li> </ul> <p>Failure to observe this warning could result in severe injury or death.</p>
---

<p><b>⚠ WARNING</b></p> <ul style="list-style-type: none"> <li>• Inspect tool before use. Replace any worn or damaged parts. A damaged or improperly assembled tool can break and strike nearby personnel.</li> <li>• Inspect the hydraulic hoses and couplings every operating day. Repair or replace if leakage, cracking, wear, or damage is evident. Damaged hoses or couplings can fail, resulting in injury or property damage.</li> <li>• Use this tool for manufacturer's intended use only. Use other than that which is described in this manual could result in injury or property damage.</li> </ul> <p>Failure to observe these warnings could result in severe injury or death.</p>
---

## **IMPORTANT SAFETY INFORMATION**

### **⚠ CAUTION**

- Do not operate the tool without a set of dies in place. Damage to the ram or crimping tool head can result.
- Maintain proper footing to prevent loss of balance in case of unexpected movement of the crimping tool.
- Do not perform any service or maintenance other than as described in this manual. Injury or damage to the tool may result.

Failure to observe these precautions may result in injury and property damage.

### **⚠ CAUTION**

Hydraulic oil can cause skin irritation.

- Handle the tool and hoses with care to prevent skin contact with hydraulic oil.
- In case of accidental skin contact with hydraulic oil, wash the affected area immediately to remove the oil.

Failure to observe these precautions may result in injury.

### **IMPORTANT**

Procedure for connecting or disconnecting hydraulic hoses, fittings, or components:

1. Move the flow lever on the hydraulic power source to the OFF position.
2. Stop the hydraulic power source.
3. Follow the sequence under “Hose Connections” to prevent pressure buildup. In case some pressure has built up, loosen hoses, fittings, or components slowly.

### **IMPORTANT**

Emergency stop procedure:

1. Release the trigger.
2. Shut off the hydraulic power source.

*Note: Keep all decals clean and legible, and replace when necessary.*

## Identification

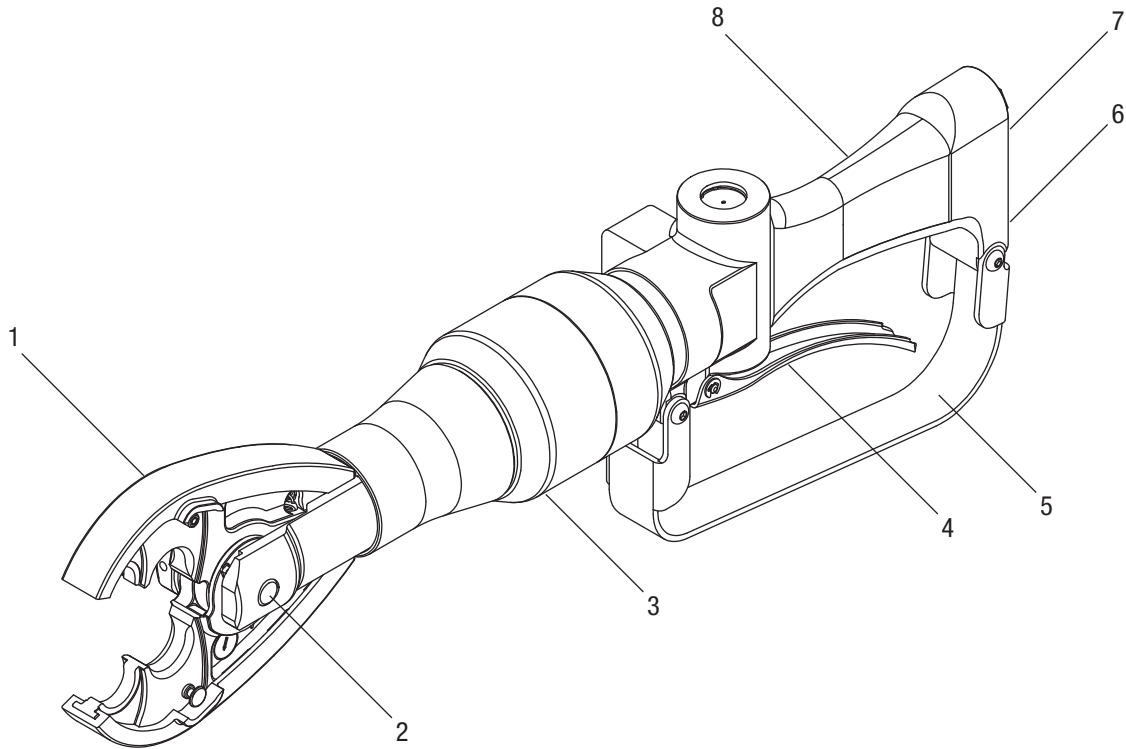

- |                  |                           |
|------------------|---------------------------|
| 1. Crimping Head | 5. Trigger Strap          |
| 2. Lock Pin      | 6. Pressure (supply) Port |
| 3. Cylinder      | 7. Tank (return) Port     |
| 4. Trigger       | 8. Handle                 |

## Specifications

### LP6 Crimping Tool

Type of Hydraulic System: Open-center or closed-center

Hydraulic Ports:

Pressure (supply): 3/4-16 UNF SAE O-ring Boss

Tank (return): 3/4-16 UNF SAE O-ring Boss

Noise Levels

$L_{WA}$  (Sound Power Level): 55.5 dB

$L_{pCpeak}$  (Peak Emission Sound Pressure Level): 68.8 dB

Vibration: 3.15 ms<sup>2</sup>

Crimping Force: 53 kN (6 tons)

Length:

With Couplers: 597 mm (23.50")

Without Couplers: 527 mm (20.75")

Width: 76 mm (3.00")

Depth: 165 mm (6.50")

Mass/Weight: 4.2 kg (9.25 lb)

### Hydraulic Power Source

#### ⚠ WARNING

Do not exceed the following hydraulic power source maximums:

- Hydraulic flow: 34.1 l/min (9 gpm).
- Pressure relief setting: 172 bar (2500 psi).
- Back pressure: 13.8 bar (200 psi)

Failure to observe this warning could result in severe injury or death.

Type of Hydraulic System: Open-center or closed-center

Flow:

Minimum: 11.4 l/min (3 gpm)

Recommended: 22.7 l/min (6 gpm)

Maximum: 34.1 l/min (9 gpm)

Pressure Relief Setting:

Minimum: 103 bar (1500 psi)

Maximum: 172 bar (2500 psi)

Filtration: 10 micron (nominal)

Back Pressure (maximum\*): 13.8 bar (200 psi)

\* 13.8 bar (200 psi) is the maximum agreed standard back pressure for the HTMA (Hydraulic Tool Manufacturers Association). Greenlee Utility tools will operate satisfactorily at this standard.

1. Maximum hydraulic fluid temperature must not exceed 60 °C (140 °F). A sufficient oil cooling capacity is needed to limit the hydraulic fluid temperature.
2. Hydraulic flow must not exceed 34.1 l/min (9 gpm). Install a flow meter in the return line to measure the rate of hydraulic flow before using the tool.
3. Pressure relief valve setting must not exceed 172 bar (2500 psi) at your tool's maximum flow. Locate the pressure relief valve in the supply circuit to limit excessive hydraulic pressure to the tool.

### Hydraulic Schematic

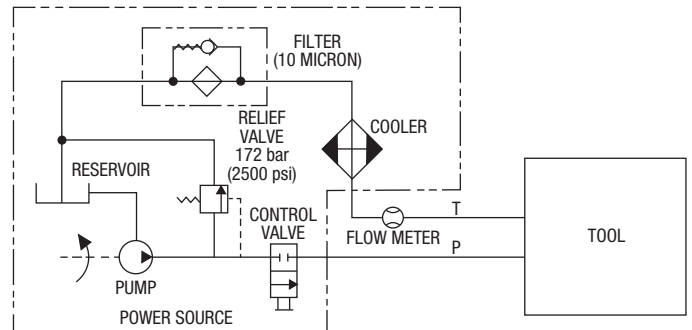

### Recommended Hydraulic Fluids

Use any nondetergent, petroleum-based hydraulic fluid which meets the following specifications or HTMA specifications.

S.U.S. @:

38 °C (100 °F): 140 to 225

99 °C (210 °F): 40 minimum

Flash Point: 170 °C (340 °F) minimum

Pour Point: -34 °C (-30 °F) minimum

## Hoses and Fittings

### Installation and Maintenance

Refer to publication 99930323, SAE J1273 (Hose and Hose Assemblies).

### Replacement

Refer to a Greenlee Utility catalog or publication 99910322, Low Pressure Quick Couplers, Adapters and Hoses.

## ⚠ WARNING

Do not disconnect tool, hoses, or fittings while the power source is running or if the hydraulic fluid is hot. Hot hydraulic fluid can cause serious burns.

## Hose Connections

### Tool Port Identification

Three methods are used to identify the pressure and return ports of Greenlee Utility tools. Match the markings on your tool to this table.

Pressure Port	Return Port
P	T
or	
In	Out
or	
3/4-16 O-ring Boss	

### Connecting Hoses

1. Move the flow control lever on the hydraulic power source to the OFF position.
2. Stop the hydraulic power source.
3. Connect the return hose to the return port on the power source, and then to the return port on the tool.
4. Connect the pressure hose to the pressure port on the tool, and then to the pressure port on the power source.

### Disconnecting Hoses

1. Move the flow control lever on the hydraulic power source to the OFF position.
2. Stop the hydraulic power source.
3. Disconnect the pressure hose from the power source, and then from the tool.
4. Disconnect the return hose from the tool, and then from the power source.

## Typical Setup

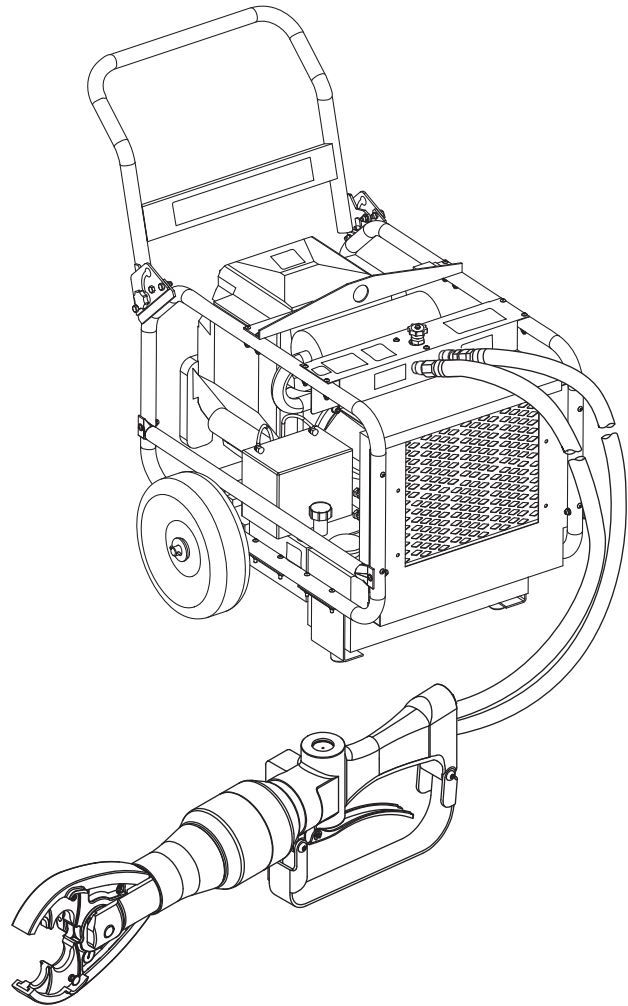



## Operation

	<b>⚠ WARNING</b>
	<p>Electric shock hazard:</p> <p>This tool is not insulated. When using this unit near energized electrical lines, use only certified non-conductive hoses and proper personal protective equipment.</p> <p>Failure to observe this warning could result in severe injury or death.</p>

<b>⚠ WARNING</b>
<p>An incomplete crimp can cause a fire.</p> <ul style="list-style-type: none"> <li>• Use proper die, connector, and cable combinations. Improper combinations can result in an incomplete crimp.</li> <li>• The relief valve sounds to indicate a completed crimp. If you do not hear the sound of the relief valve, the crimp is not complete.</li> </ul> <p>Failure to observe these warnings could result in severe injury or death.</p>

	<b>⚠ WARNING</b>
	<p>Skin injection hazard:</p> <ul style="list-style-type: none"> <li>• Do not use hands to check for leaks.</li> <li>• Do not hold hose or couplers while the hydraulic system is pressurized.</li> <li>• Depressurize the hydraulic system before servicing.</li> </ul> <p>Oil under pressure easily punctures skin, causing serious injury, gangrene, or death. If you are injured by escaping oil, seek medical attention immediately.</p>

1. Refer to the connector manufacturer's instructions for cable preparation and the crimping procedure.
2. Center the connector between the dies or nibs.
3. Press the trigger to advance the dies or nibs.
  - Press the trigger down completely for fast advance.
  - Press the trigger down partially for slow advance.
4. Continue crimping until the pressure relief valve activates.
 

*Note: Pressure relief is indicated by a change in the sound from the crimping tool and a sudden stiffening of the hydraulic hoses.*
5. After achieving pressure relief, release the trigger. The dies retract.
6. Complete the number of crimps specified by the connector manufacturer.
7. When the tool is not in use, stop the power source to reduce heat and wear on tool components.

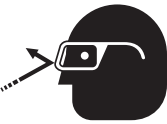
	<b>⚠ WARNING</b>
	<p>Wear eye protection when operating or servicing this tool.</p> <p>Failure to wear eye protection could result in serious eye injury from flying debris or hydraulic oil.</p>

	<b>⚠ WARNING</b>
	<p>Keep hands away from the crimping tool head when crimping.</p> <p>Failure to observe this warning could result in severe injury or death.</p>

## Operation (cont'd)

### Die Selection

Interchangeable dies may be used in the standard die opening. Dies that may be used include:

- Greenlee KD6 series
- Burndy W and X series
- ILSCO ND series
- Huskie HT58 series
- Panduit CD-2001 series
- Other industry W-type dies

### Installing Dies

1. Select the proper dies for the connector to be crimped.
2. Install dies in jaws making certain that they are properly secured by the spring-loaded, positive lock, die buttons.

### Preparing Cable

Follow the lug manufacturer's instructions for appropriate cable strip length.

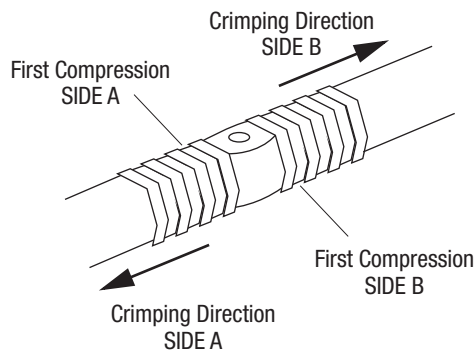
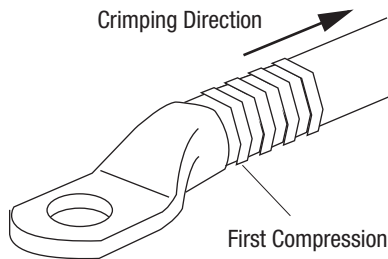

### Crimping Procedure

1. Insert conductor into the connector and align the tool and die on the connector. Start in the center for splices and "H" frames; and on the end, nearest the pad, for terminals.
2. Activate the tool by pulling the trigger.
3. Continue crimping the connector until the correct number of crimps has been completed. Work from the center to the outer edges for splices and "H" frame connectors, alternating sides if possible, for the best compression connections.

## WARNING

An incomplete crimp can cause a fire.

- Use proper die, connector, and cable combinations. Improper combinations can result in an incomplete crimp.
- The relief valve sounds to indicate a completed crimp. If you do not hear the sound of the relief valve, the crimp is not complete.

Failure to observe this warning could result in severe injury or death.

## Maintenance

	<b>⚠ WARNING</b>
	<p>Skin injection hazard:</p> <ul style="list-style-type: none"> <li>Do not use hands to check for leaks.</li> <li>Do not hold hose or couplers while the hydraulic system is pressurized.</li> <li>Depressurize the hydraulic system before servicing.</li> </ul> <p>Oil under pressure easily punctures skin, causing serious injury, gangrene, or death. If you are injured by escaping oil, seek medical attention immediately.</p>

	<b>⚠ WARNING</b>
	<p>Wear eye protection when operating or servicing this tool.</p> <p>Failure to wear eye protection could result in serious eye injury from flying debris or hydraulic oil.</p>

### Notes:

- Keep all decals clean and legible. Replace decals when necessary.
- When disposing of any components (hydraulic hoses, hydraulic fluid, worn parts, etc.), do so in accordance with federal, state and local laws or ordinances.

### Daily

- Thoroughly wipe all tool surfaces clean. Remove any oxide inhibitor, connector contact compound, and grit from the die seat areas, dies and die holders.
- Inspect the hydraulic hoses and fittings for signs of leaks, cracks, wear or damage. Replace if necessary.
- Install dust caps over the hydraulic ports when the tool is disconnected.

### Monthly

- Perform a thorough inspection of the hydraulic hoses and fittings as described in publication 99930323, SAE J1273 (Hose and Hose Assemblies).
- Apply a light oil to all moving parts.

### Quarterly or Every 500 Crimps

Perform the "Periodic Pressure Relief Valve Check."

### Annually

If required by your organization's regulations, send the tool to a Greenlee Utility Authorized Service Center.

## Periodic Pressure Relief Valve Check

Test the crimping tool periodically to ensure that the pressure relief valve activates at the proper pressure.

- Test the crimping tool with an in-line pressure gauge.  
Install an in-line pressure gauge on the input side of the tool. With dies in place, perform a test crimp.
- Pressure relief should occur at 103 to 107 bar (1500 to 1550 psi).
- If pressure relief occurs outside of the specified range, send the crimping tool to a Greenlee Utility Authorized Service Center.

## Troubleshooting

Before troubleshooting, determine whether the problem is in the tool, the hoses, or the power source. Substitute a tool, hoses, or power source known to be in good working order to eliminate the item that is not operating.

If the problem is in the tool, see the troubleshooting table in this manual. If the problem is in the power source, see the troubleshooting section of the power source instruction manual.

Problem	Probable Cause	Probable Remedy
Tool does not operate.	Improper power source.	Verify that the power source meets the specifications. Refer to the “Specifications” section.
	Hydraulic fluid level low.	Check the fluid level. Check system for leaks.
	Incorrect hydraulic fluid viscosity.	Use hydraulic fluid with the correct viscosity. Refer to the “Specifications” section.
Tool operates slowly or erratically.	Hydraulic fluid cold.	Allow fluid to warm to the operating temperature. Actuate the tool intermittently to reduce the warming time.
	Power source not adjusted correctly.	Refer to the power source operator’s manual. Set the flow and pressure to correspond with the tool.
	Hydraulic fluid level low.	Check the fluid level. Check system for leaks.
	Air in the hydraulic system.	Refer to the power source manufacturer’s instructions for removing air from the system.
	Incorrect hydraulic fluid viscosity.	Use hydraulic fluid with the correct viscosity. Refer to the “Specifications” section.
Tool feels hot.	Hydraulic fluid level low.	Check the fluid level. Check for leaks.
	Incorrect hydraulic fluid viscosity.	Use hydraulic fluid with the correct viscosity. Refer to the “Specifications” section.
	Hydraulic fluid dirty.	Refer to the power source owner’s manual for procedure to replace hydraulic oil and filter.
Tool operates backward.	Hose connections at tool are reversed.	Depressurize the hydraulic system. Switch the hose connections.
Crimping tool does not achieve pressure relief.	Improper power source.	Verify that the power source meets the specifications. Refer to the “Specifications” section.
Dies do not retract.	Dies caught on crimped connector.	Twist crimping tool from side to side to free it from the connector.
	Excessive system back pressure.	Troubleshoot the hydraulic system.

**Illustration**

**Main**

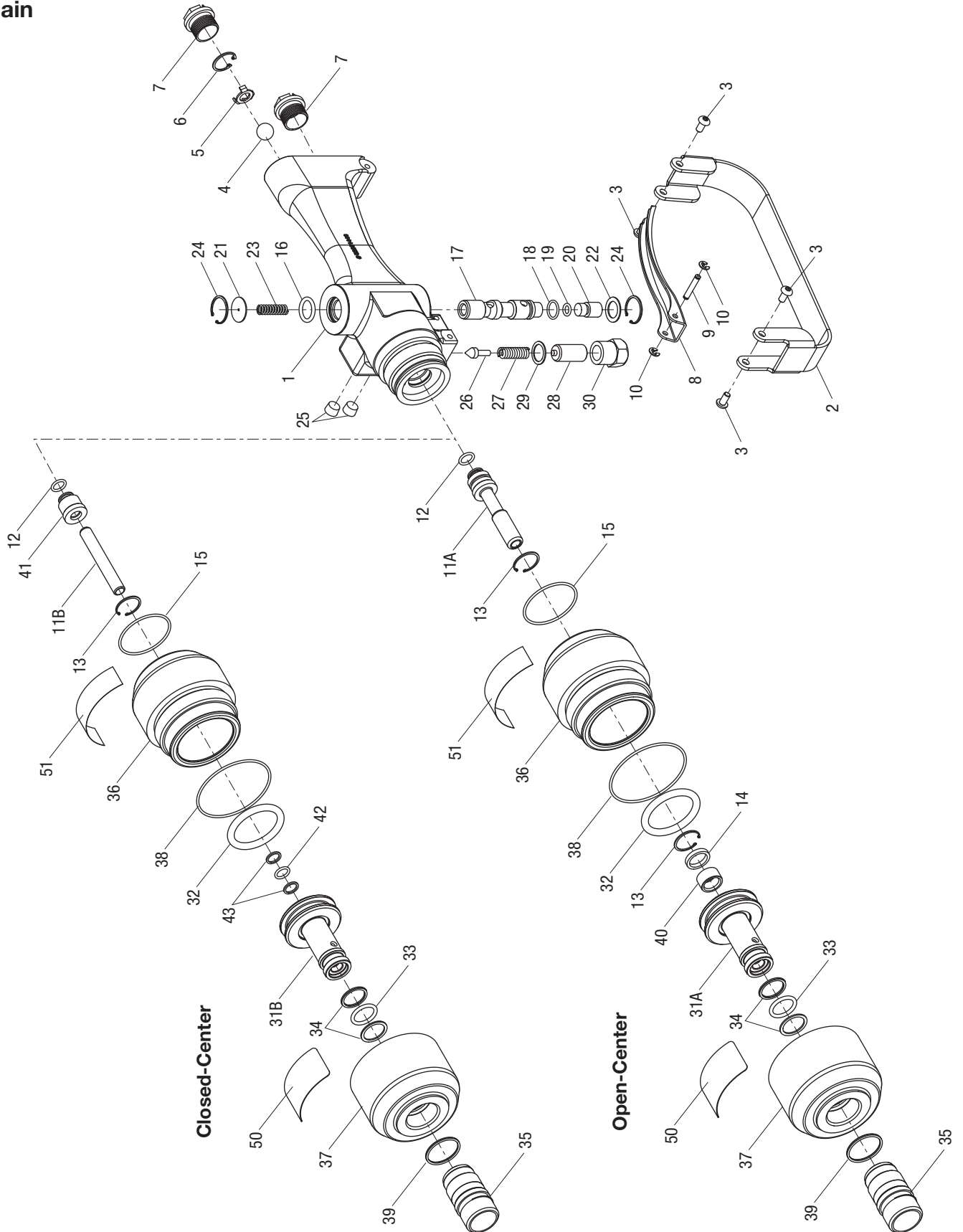

## Illustration

### Ram Unit

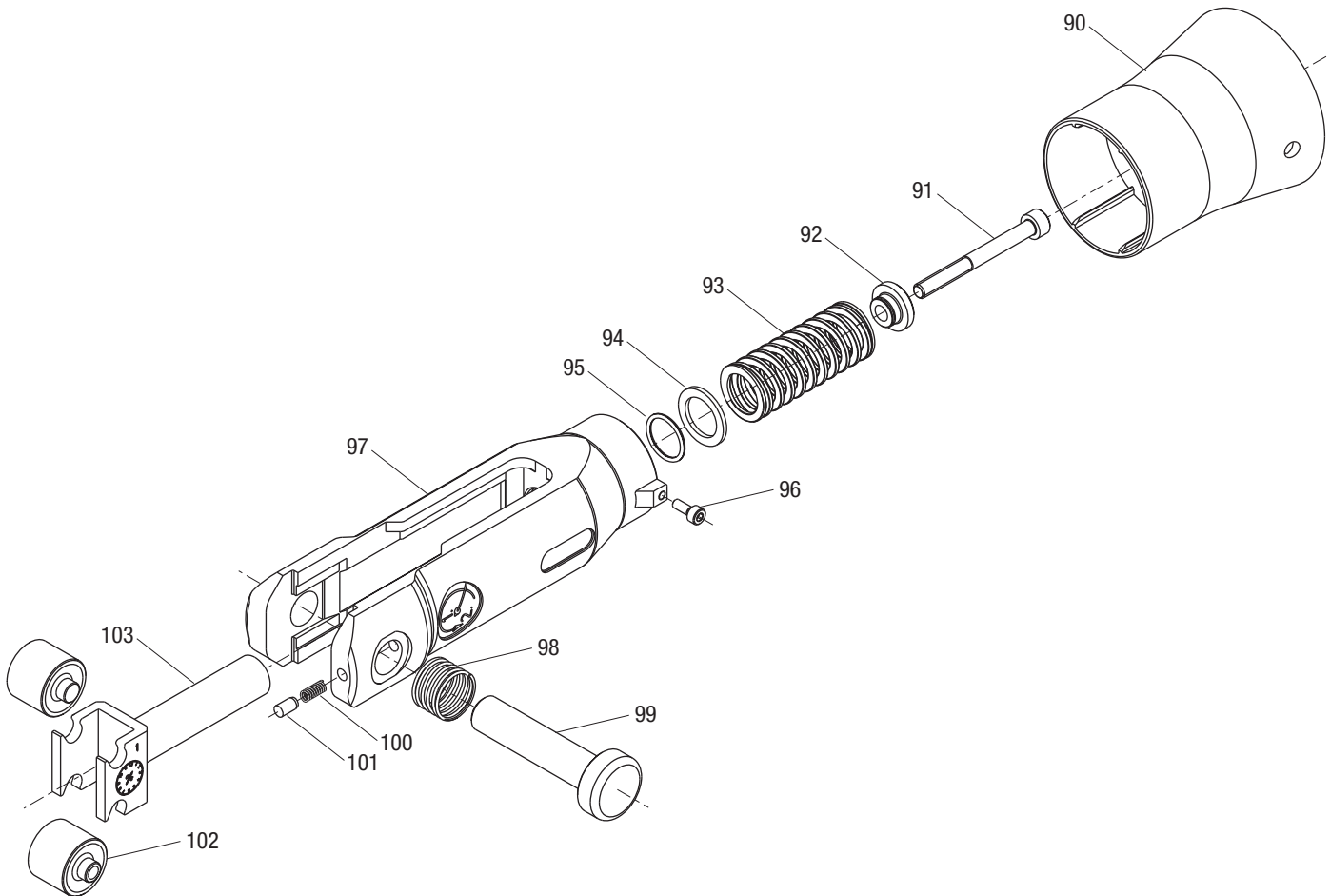

**Illustration**

**Crimping Jaw Units**

**CJD3BG**

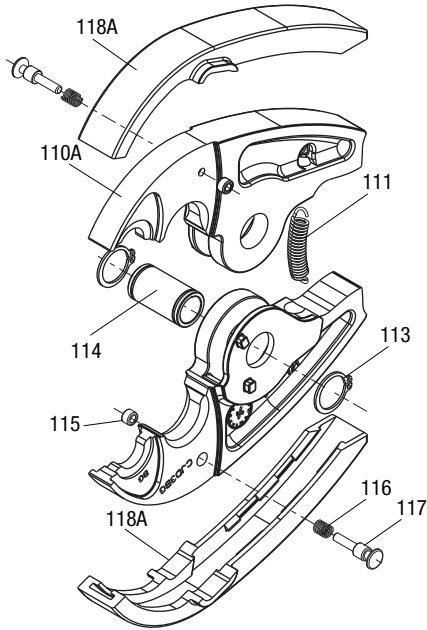

**CJD30**

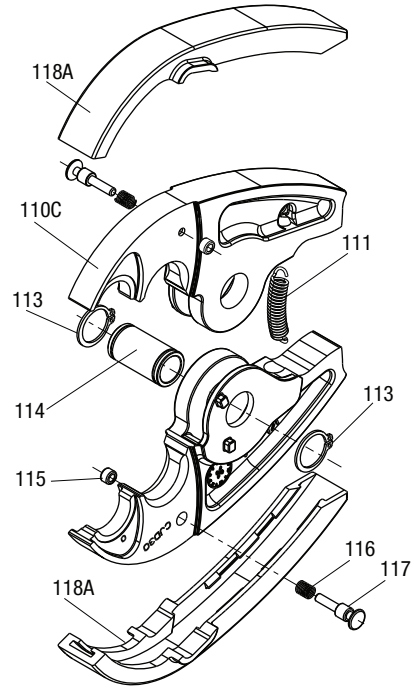

**CJD3**

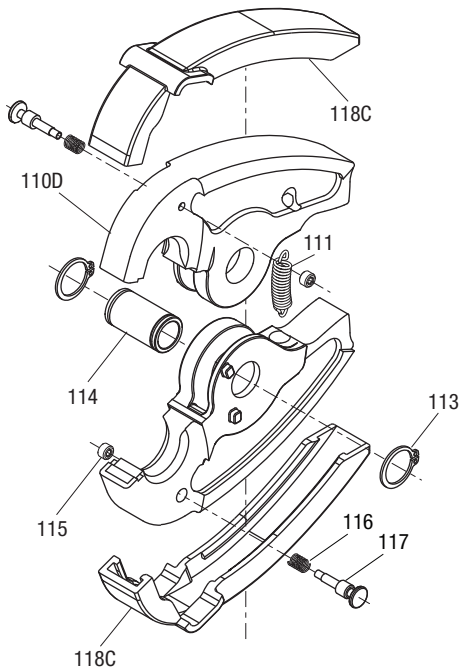

**CJK Kearney**

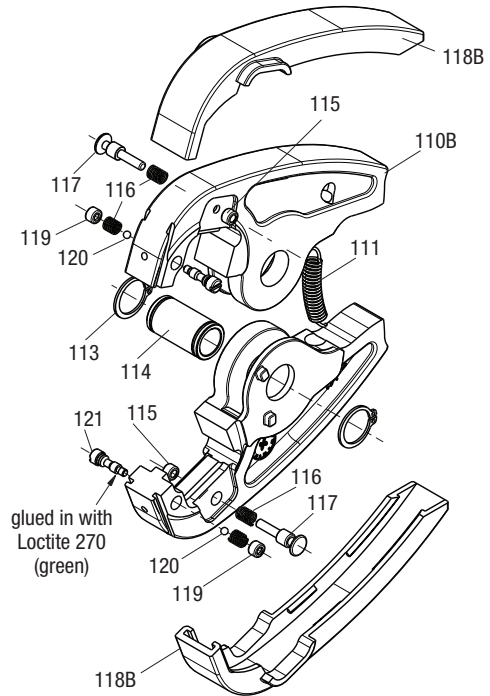

## Parts List

Key	Part No.	Description	Qty	Key	Part No.	Description	Qty
1	52062991	Handle, machined .....	1		52048133	<b>Ram unit</b> (includes 90–103) .....	1
2	50436996	Strap, trigger .....	1	90	52049292	Sheath .....	1
3		Screw, cap-skt btn hd (#10-32 x .375) .....	4		52049399	Spring kit (includes 91–95)	
4	50418730	Ball.....	1	91		Bolt, shoulder .....	1
5	50492349	Stop, ball .....	1	92		Disc.....	1
6		Ring, retaining .....	1	93		Compression spring .....	1
7	50414323	Plug, plastic.....	2	94		Washer.....	1
8	50425760	Trigger.....	1	95		O-ring .....	1
9		Pivot, trigger .....	1		52057497	Jaw holder kit (includes 90, 96, 97).....	1
10		Ring, retaining .....	2	96	52057496	Screw.....	1
11A	52065313	Tube, return (O-C only) .....	1	97		Jaw holder.....	1
11B	52062719	Tube, center (C-C only).....	1		52049400	Latch kit (includes 98–101)	
12*		O-ring .....	1	98		Compression spring .....	1
13*		Ring, retaining (qty 2 for O-C) .....	1	99		Locking pin.....	1
14	50425441	Retainer, seal (O-C only) .....	1	100		Compression spring .....	1
15*		O-ring .....	1	101		Pin .....	1
16*		O-ring .....	1		52049401	Roller kit (includes 102 and 103)	
17	52063245	Spool .....	1	102		Roller .....	2
18*		O-ring .....	1	103		Ram .....	1
19*		O-ring, packing.....	1		52027121	<b>CJD3BG crimping jaw unit</b> (includes 110–118)	
20	50435566	Plug .....	1		52027122	<b>CJD3O crimping jaw unit</b> (includes 110–118)	
21	50410952	Cap.....	1		52024068	<b>CJD3 crimping jaw unit</b> (includes 110–118)	
22	50434012	Washer.....	1		52020114	<b>CJK Kearney crimping jaw unit</b> (includes 110–118, 119-121)	
23	50428651	Spring, valve-plunger .....	1	110A		Jaw, CJD3BG .....	2
24		Ring, retaining .....	2	110B		Jaw, CJK .....	2
25		Plug, pipe-coated.....	2	110C		Jaw, CJD3O .....	2
26	50301462	Pin, valve .....	1	110D		Jaw, CJD3 .....	2
27	50406921	Spring, valve-unloading.....	1	111	52022544	Extension spring.....	1
28	50482610	Screw, set-adjusting (1/2-20 x 1.00) .....	1		52049402	Jaw pivot kit (includes 113 and 114)	
29	50406461	Washer, copper .....	1	113		Retaining ring .....	2
30	50482602	Cap.....	1	114		Pin pivot.....	1
31A	52064083	Piston (O-C only) .....	1	115		Bushing .....	2
31B	52062762	Piston (C-C only) .....	1	116		Compression spring .....	2
32*		O-ring (1-1/2 x 1-7/8 x 3/16 nitrile).....	1	117		Lock adapter .....	2
33*		O-ring (11/16 x 7/8 x 3/32 nitrile).....	1	118A	52025125	Jaw covers, CJD3O/CJD3BG (set of 2) ....	1
34*		Ring, backup .....	2	118B	52022386	Jaw covers, CJK (set of 2).....	1
35	52062768	Cylinder sleeve .....	1	118C	52021086	Jaw covers, CJD3 (set of 2) .....	1
36	52062763	Cylinder .....	1	119		Bushing .....	2
37	52062764	Cap.....	1	120		Ball, 3 mm .....	2
38*		O-ring (2-3/8 x 2-1/2 x 1/16) .....	1	121		Locking pin.....	1
39*		O-ring (26 x 30 x 2).....	1		50103750	Die pin kit, "W"-style dies (includes 115–117)	
40	50425431	Seal, bypass (O-C only).....	1		50105108	Die pin kit, Kearney-style dies (includes 116, 119–121)	
41	50426851	Carrier, seal (C-C only) .....	1		52064102	Hardware kit (includes 3, 6, 9, 10, 13, 24, and 25)	
42	50413313	O-ring (3/8 x 1/2 x 1/16) (C-C only) .....	1	*	52064103	Seal kit (includes items marked with an asterisk)	
43	50435450	Ring, backup (C-C only) .....	2				
	52064101	Decal kit (includes 50–52)					
50		Decal, Greenlee Utility .....	1				
51		Decal, warning.....	1				
52		Decal, pinch hazard warning (not shown).....	1				