

a sound relationship
Russound

MIXAMP-60

70W Mixer Amplifier with Media Player

Built-in FM Tuner, Bluetooth, USB/SD Audio

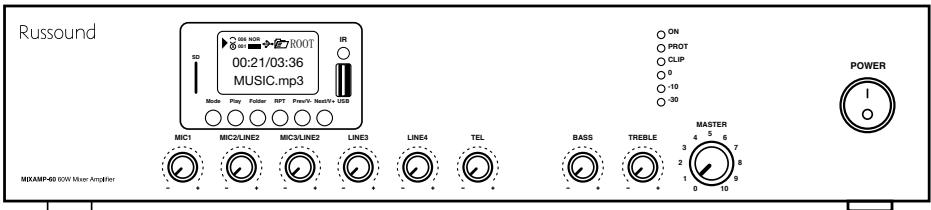

SAFETY WARNINGS

SAFETY WARNINGS

1. Read and keep these instructions.
2. Heed all warnings and follow all instructions.
3. Do not use this apparatus near water.
4. Do not block any ventilation openings. Install in accordance with the manufacturer's instructions.
5. Do not install near any heat sources such as radiators, heat registers, stoves, or other apparatus that produce heat.
6. Do not defeat the safety purpose of the polarized or grounding-type plug. A polarized plug has two blades with one wider than the other. A grounding type plug has two blades and a third grounding prong. The wide blade or the third prong is provided for your safety. If the provided plug does not fit into your outlet, consult an electrician for replacement of the obsolete outlet.
7. Protect the power cord from being walked on or pinched particularly at plugs, convenience receptacles, and the point where they exit from the apparatus.
8. Only use attachments/accessories specified by the manufacturer.
9. Use only with the cart, stand, tripod, bracket, or table specified by the manufacturer, or sold with the apparatus. When a cart is used, use caution when moving the cart/apparatus combination to avoid injury from tip-over.
10. Unplug this apparatus during lightning storms or when unused for long periods of time.
11. Refer all servicing to qualified service personnel. Servicing is required when the apparatus has been damaged in any way, such as power-supply cord or plug is damaged, liquid has been spilled or objects have fallen into the apparatus, the apparatus has been exposed to rain or moisture, does not operate normally, or has been dropped.
12. This appliance shall not be exposed to dripping or splashing water and no object filled with liquid such as vases shall be placed on the apparatus.
13. Plug this apparatus into the proper wall outlet and make the plug can be easily disconnected.
14. Main plug is used as the disconnect device and it should remain readily operable during intended use. In order to disconnect the apparatus from the mains completely, the mains plug should be disconnected from the mains socket outlet completely.
15. **WARNING:** To reduce the risk of fire or electric shock, do not expose this apparatus to rain or moisture.
16. An appliance with a protective earth terminal should be connected to a mains outlet with a protective earth connection.

WARNING!

TO PREVENT FIRE OR SHOCK HAZARD, DO NOT USE THE PLUG WITH AN EXTENSION CORD, RECEPTACLE OR OTHER OUTLET UNLESS THE BLADES CAN BE FULLY INSERTED TO PREVENT BLADE EXPOSURE.

TO REDUCE THE RISK OF FIRE OR ELECTRIC SHOCK, DO NOT EXPOSE THIS APPLIANCE TO RAIN OR MOISTURE.

TO PREVENT ELECTRICAL SHOCK, MATCH WIDE BLADE PLUG TO WIDE SLOT, FULLY INSERT.



The lightning flash with arrowhead symbols, within an equilateral triangle, is intended to alert the user to the presence of uninsulated "dangerous voltage" within the products enclosure that may be of sufficient magnitude to constitute a risk of electric shock to persons.

CAUTION

**RISK OF ELECTRIC SHOCK
DO NOT OPEN**

WARNING: TO REDUCE THE RISK OF ELECTRIC SHOCK DO NOT REMOVE COVER (OR BACK) NO USER SERVICEABLE PARTS INSIDE REFER SERVICING TO QUALIFIED SERVICE PERSONAL



The exclamation point within an equilateral triangle is intended to alert the user to the presence of important operating and maintenance (servicing) instructions in the literature accompanying the appliance

CAUTION: Touching uninsulated terminals or wiring may result in electric shock

Ventilation Requirements

Important: The MixAmp-60 should be situated so that its location or position does not interfere with its proper ventilation. Do not block vents above or to the sides of the unit, as it requires ventilation for proper operation. Do not expose to excessive dust, and do not allow dust to build up on the unit and block ventholes. Do not place the MixAmp-60 directly above or below a heat-generating component such as an audio amplifier.

Be sure to leave at least 2 inches of space to the sides of the unit with open airflow above. A single-space rack mount vent or about 1.75 inches must be kept clear above and below the unit.

Installation

The MixAmp-60 can be rack mounted or placed on a shelf in an equipment rack. It occupies two rack spaces with feet removed. Use only the included rack mount ears and hardware to rack mount the MixAmp-60.

Electrical Power

The MixAmp-60 operates at 110-230VAC at 50/60 Hz. It is recommended that the MixAmp-60 and any connected source equipment be plugged into a dedicated 20-amp circuit. A power line conditioner can reduce interference problems caused by noise found in some electrical systems. The power switch for the unit is on the front panel.

Important Considerations

- This product is to be operated by trained personnel only.
- Disconnect the power cord before making any wiring connections to the device.
- Verify that all connections and wiring polarity are correct.
- Keep all power cords away from all signal cables to prevent humming from induced noise.
- Choose reliable signal cables and patch cords.
- Label all wires with the room location at both ends of the wire.
- Avoid running speaker wires or signal cables close to electrical wiring for any distance. If you have to run them parallel, make sure to space the wires at least two feet from the AC line. If you need to cross an AC line it should be at a 90° angle.
- Do not connect the main power cord until all other connections have been made and verified. Live connection or removal of source or speaker wiring or other wiring when the system is powered can result in erratic operation or system damage. Touching live terminals or wiring can result in shock.
- Double-check terminations during each phase of the installation to prevent accidental damage. Incorrect wiring is the number one cause for non-warranty product damage.

Overview

Description

The MixAmp-60 Mixer Amplifier with MP3, FM tuner & **Bluetooth**, is ideal for schools, supermarkets, convenience stores, banks, retail stores and similar environments. It is an all-in-one solution with built-in audio sources, pre-amp mixing, audio amplification, expandability to external sources, microphones, etc., in one small, rack-mountable chassis.

The MixAmp-60 integrates combinations of up to 3 microphones and 4 external audio sources in addition to its built-in FM Tuner, Bluetooth receiver, USB, and SD card MP3 player. Convenient front panel controls allow for precise volume level of all connected sources as well as an integrated LCD display showing currently selected audio from the built-in sources. Background Music (BGM) and Music On Hold (MOH) integration are available as well as a Telephone Paging Input. Phantom Power is available for the primary microphone as well as adjustable ducking levels.

Features

- Compact Design
- Built-in 70V/100V transformer technology
- Tabletop amplifier with MP3 player, FM radio & Bluetooth
- 60W Power Output
- Speaker outputs of 70V, 100V, 4 Ohms, 8 Ohms, and 16 Ohms
- MP3 player with USB/SD input on front panel, IR remote control for MP3 player, FM radio and Bluetooth
- LED indicators for power, clipping, protection and signal
- Mic 1 is a balanced XLR input with configurable phantom power support. Mics 2 & 3 are switchable, unbalanced, removable screw-down Phoenix connectors types and can alternate between microphones or line inputs.
- Includes a built-in telephone input with VOX priority and MOH (Music on Hold) output.
- Convenient Front-Panel Volume Controls for all physical inputs, MP3/FM, master volume as well as bass/treble
- Line out for use with an optional external amplifier if more power is needed
- Built-in short-circuit, clipping, overload and over-temperature protection

FRONT PANEL

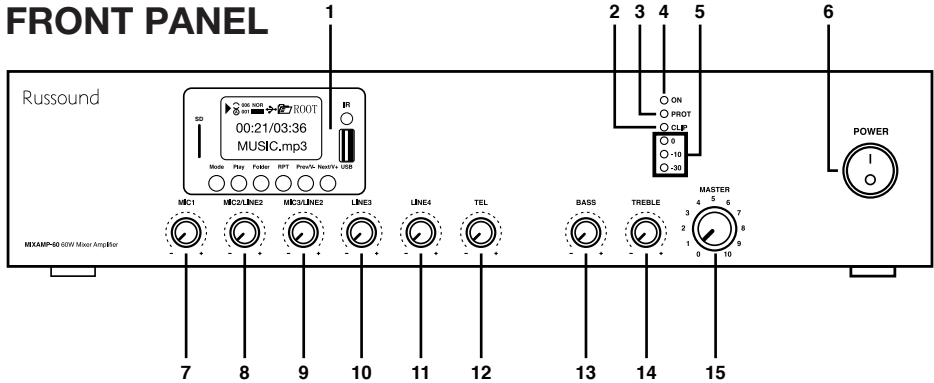

- | | | |
|----------------------------------|--------------------------|---------------------------|
| 1. MP3/FM/Bluetooth Media Player | 7. Mic 1 Level | 13. Bass |
| 2. Power Status | 8. Mic 2 / Input 1 Level | 14. Treble |
| 3. Protection Status | 9. Mic 3 / Input 2 Level | 15. Master Volume Control |
| 4. Clipping Status | 10. Input 3 Level | |
| 5. Output Level | 11. Input 4 Level | |
| 6. Main Power Switch | 12. Tel Input Level | |

BACK PANEL

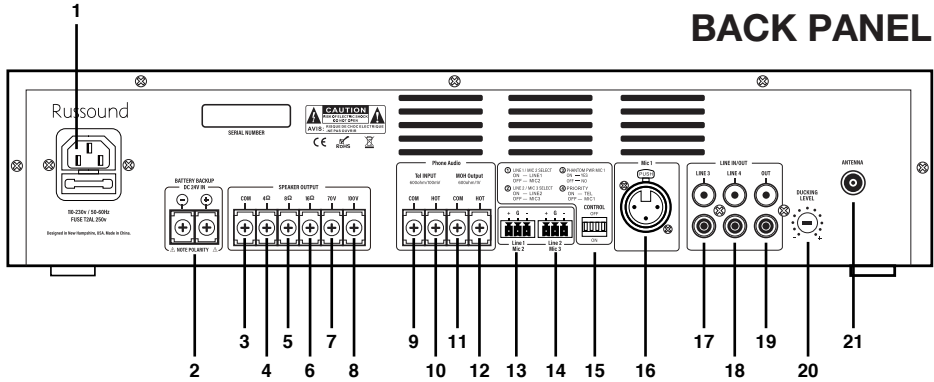

- | | | |
|------------------------------------|--|------------------------------------|
| 1. AC Power In | 9. Telephone Input COM (-) | 16. Microphone 1 Input |
| 2. Optional 24V DC Battery Input | 10. Telephone Input HOT (+), 600 Ohms, 1 Volt | 17. Line 3 Input |
| 3. Common Speaker Output (COM (-)) | 11. Music on Hold (MOH) Output COM (-) | 18. Line 4 Input |
| 4. Speaker Output 4 Ohms (+) | 12. Music on Hold (MOH) Output HOT (+) | 19. Line Output |
| 5. Speaker Output - 8 Ohms (+) | 13. Input 2 Mic/Line Selector | 20. Ducking Audio Level Adjustment |
| 6. Speaker Output - 16 Ohms (+) | 14. Input 3 Mic/Line Selector | 21. Antenna |
| 7. Speaker Output - 70V (+) | 15. Dipswitch for Mic/Line Selector, Phantom Power and Microphone Priority | |
| 8. Speaker Output - 100V (+) | | |



Male XLR-3P:
 Pin1-Ground
 Pin2-Positive signal
 Pin3- Negative signal

Basic Wiring Overview

70V/100V Line Systems

For 70V/100V line systems, connect the amplifier to the first speaker in the system using double-insulated speaker wire rated to handle the total output of the amplifier.

Connect the “70V” or “100V” output terminal to the positive (+) connection of the speaker and “COM” output to the negative (-) connection of the speaker. Connect further speakers in parallel to the first speaker with all positive terminals connected together and all negative terminals connected together as shown below.

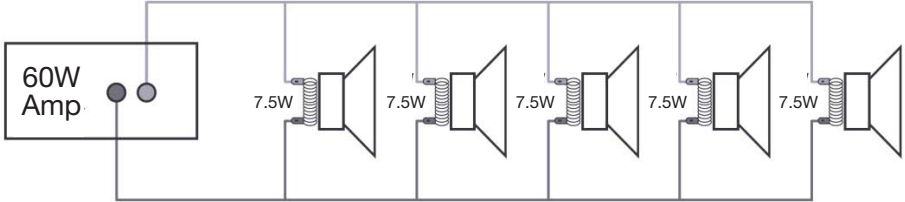

A 70V/100V line speaker system can comprise of many speakers connected together. The determining factor for how many speakers can be used on a single amplifier is the power rating. For most purposes, it is advised to connect as many speakers as needed with a combined wattage of no more than 80% of the amplifier’s output power rating.

The terminals of a 70V/100V speaker are connected to a transformer and in some cases, this transformer may be “tapped” for different power ratings. These tap settings can be used to adjust the wattage (and output volume) of each speaker in the system to help achieve the ideal total power of the system for the amplifier.

Low Impedance Speaker Terminals

The MixAmp-60 offers three low impedance options of 4Ω, 8Ω, 16Ω depending on the speaker load. Please note that one wire only should be connected to the speaker output COM screw and one wire to the selected speaker output. Low Impedance (4/8/16 ohms) and high impedance (70V/100V) cannot be used simultaneously.

Speaker Connections

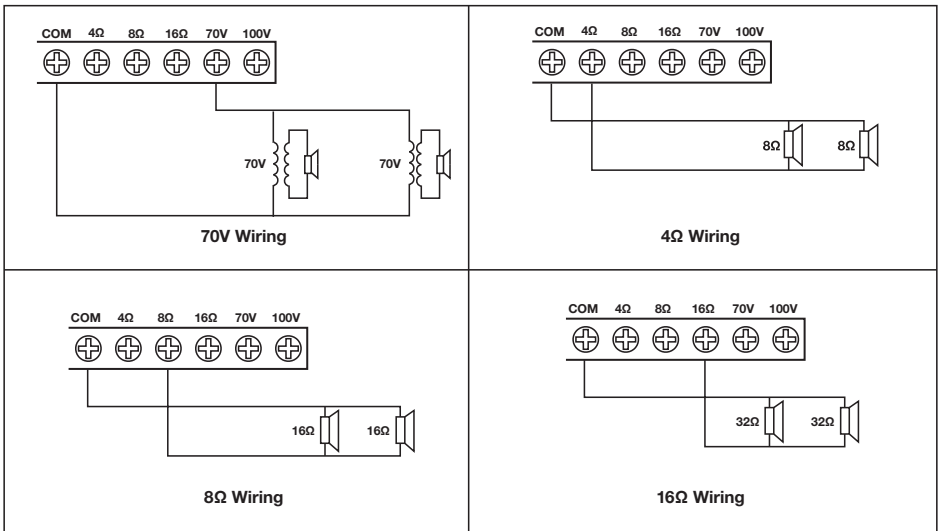

Configuration and Setup

- When all connections to the amplifier are made, turn all rotary controls down and switch on the power and the power “ON” LED will illuminate. Turn BASS and TREBLE controls to the 12 o’clock position (pointing straight up) and turn MASTER rotary control up part way for testing.
- Ensure a signal is being fed to one of the line inputs 1, 2, 3, 4 or 5 and gradually increase the volume control for that channel until the output is heard through the speakers. Turn up the MASTER to the maximum required volume level and reduce the channel volume control if necessary.
- Note: The initial test can be made using the built-in USB/SD/FM audio player. The output of the amplifier is represented on the level meter LEDs and care should be taken that the Red “0” LED is only lit momentarily during use. Anything longer than a short flash of this LED may be indicating distortion or clipping of the output signal and the MASTER should be turned down.
- If a microphone is connected to MIC1 input, make sure it is switched on and if it requires phantom power, make sure this feature is enabled. Gradually increase its volume control while speaking into the microphone until the required volume level is reached. The microphone should not be able to “hear” the speakers, which can cause feedback (squealing or howling noise).
- If the ducking feature is enabled, audio playback through channels 2-5 will be reduced in volume automatically when speaking into MIC 1, use its rear panel attenuator to increase or decrease the ducking mute level.
- In addition to channel and MASTER volume controls, there are BASS and TREBLE EQ controls to adjust the tone of the overall output. At the 12 o’clock position, these controls are neutral to the signal (no boost or cut). Moving the BASS control clockwise boosts the low frequencies in the audio, while moving it counter-clockwise will cut these low frequencies. Likewise, moving the TREBLE control clockwise boosts the high frequencies in the audio, while moving it counter-clockwise will cut these high frequencies. Adjust these EQ controls to suit the type of audio signal or compensate for the room acoustics.

Using the Front Panel Media Player Controls

- Mode – Use this button to toggle among Bluetooth, USB/SD, and the built-in FM Tuner
- Volume Control – Press and hold the “Prev/V-” button to decrease the media player module’s volume and press and hold “Next/V+” to increase the media player module’s volume (Max=30). For most applications we recommend setting the volume to the maximum level and leaving it at that setting. The exception to this is when you would like to use the included remote control to adjust the volume of the media player module remotely.

Using the Remote Control

The included remote control can be used for controlling the front panel media player. The remote control can adjust the volume levels of any media player source but can NOT adjust the overall amplifier master volume settings or adjust any sources other than those available on the built-in media player: Bluetooth, USB/SD, and FM Tuner.

- Power – Toggles the front panel media player On/Off
- Mode - Use this button to toggle among Bluetooth, USB/SD, and the built-in FM Tuner
- EQ - Toggles among the preset EQ settings: Normal, Rock, Pop, Classical, Jazz, Country. The current setting appears at the top of the display
- Mute - Toggles the volume mute On/Off. The current mute state will be visible in the top left of the built-in display.
- Vol-/Vol+ - Adjusts the volume level of the built-in media player. Using the remote control allows precise volume adjustments from levels 0 to 30. Pressing and holding a volume button will ramp the volume faster.

Bluetooth

Press the Mode button until seeing “BT” appear on the display.

If no phone/tablet is currently connected, the message “BT Not Link” will appear. To pair a device, go to your device’s Bluetooth settings and select “Pair a New Device” or similar to search for available devices. The Rurround MixAmp-60 uses the default Bluetooth name of ULISSE. Select this from your phone/tablet and complete the pairing process.

Your phone/tablet is now ready to send its audio output to the MixAmp-60. Play any audio content on your phone/tablet and it will play on the MixAmp-60.

For Bluetooth operation, you can use your phone/tablet’s volume control to adjust the volume levels. There will be three volume controls in operation that can each be adjusted: your phone/tablet volume, the MixAmp-60 media

player volume, and the MixAmp-60 master volume.

Front Panel Controls for Bluetooth

- Play – Toggles between Play/Pause
- Folder – Toggles among the preset EQ settings: Normal, Rock, Pop, Classical, Jazz, Country. The current setting appears at the top of the display
- Repeat – Toggles the track repeat function On/Off
- Prev – Restarts the current track. Pressing this repeatedly will cycle through previously played tracks
- Next – Skips to the next track. Pressing this repeatedly will cycle through upcoming tracks

Remote Control Commands for Bluetooth

- Power – Toggles the front panel media player On/Off
- Mute - Toggles the volume mute On/Off. The current mute state will be visible in the top left of the built-in display.
- Play/Pause – Toggles between Play/Pause
- EQ - Toggles among the preset EQ settings: Normal, Rock, Pop, Classical, Jazz, Country. The current setting appears at the top of the display
- Prev – Restarts the current track. Pressing this repeatedly will cycle through previously played tracks
- Next – Skips to the next track. Pressing this repeatedly will cycle through upcoming tracks
- Repeat – Toggles the track repeat function On/Off
- U/SD – No function during Bluetooth operation
- Numeric Buttons – No function during Bluetooth operation

FM Tuner

The built-in FM Tuner can be used as a media source. Make sure to connect the supplied antenna or suitable 3rd party 75-ohm antenna to the Antenna connection on the rear of the MixAmp-60.

Press the Mode button to cycle between Bluetooth, USB/SD, and the FM Tuner. When on the FM Tuner, you will see a frequency band display and a channel (station) indicator.

Front Panel Controls for the FM Tuner

- Play – Toggles between volume mute On/Off
- Folder – No function during FM Tuner operation
- Repeat – Initiates the auto-scan and store function to detect and store all tunable stations
- Prev – Press this button to cycle backwards through all stored stations
- Next – Press this button to cycle forwards through all stored stations

Remote Control Commands for the FM Tuner

- Power – Toggles the front panel media player On/Off
- Mute - Toggles the volume mute On/Off. The current mute state will be visible in the top left of the built-in display.
- Play/Pause – Toggles the volume mute On/Off. The current mute state will be visible in the top left of the built-in display.
- EQ - No function during FM Tuner operation
- Prev – Press this button to cycle backwards through all stored stations
- Next – Press this button to cycle forwards through all stored stations
- Repeat – Initiates the auto-scan and store function to detect and store all tunable stations
- U/SD – No function during FM Tuner operation
- Numeric Buttons – No function during FM Tuner operation. There is no direct entry feature to tune to a station.

USB/SD Media Player

The media player on the MixAmp-60 can be used to play audio files stored on a FAT32 thumb drive or on a microSD card.

Playback is initiated automatically when a new USB or microSD card is inserted. Playback can be controlled through either the front panel buttons or by using the included remote control.

The front panel display will show the name of the currently playing track.

If a USB or microSD card is already inserted, press the Mode button to cycle between Bluetooth, USB/SD, and the FM Tuner.

Front Panel Controls for the USB/SD Player

- Play – Toggles between Play/Pause
- Folder – Restarts the first track on the USB/SD Player
- Repeat – Toggles the track repeat function through various positions – repeat all, repeat track, random (shuffle)
- Prev – Restarts the current track. Pressing this repeatedly will cycle through previously played tracks. (Pressing and holding this button will lower the media player volume level)
- Next – Skips to the next track. Pressing this repeatedly will cycle through upcoming tracks. (Pressing and holding this button will raise the media player volume level)

Remote Control Commands for the USB/SD Player

- Power – Toggles the front panel media player On/Off
- Mute - Toggles the volume mute On/Off. The current mute state will be visible in the top left of the built-in display.
- Play/Pause – Toggles between Play/Pause
- EQ - Toggles among the preset EQ settings: Normal, Rock, Pop, Classical, Jazz, Country. The current setting appears at the top of the display
- Prev – Restarts the current track. Pressing this repeatedly will cycle through previously played tracks. Pressing and holding this button will fast forward the audio within the currently playing track.
- Next – Skips to the next track. Pressing this repeatedly will cycle through upcoming tracks. Pressing and holding this button will rewind the audio within the currently playing track.
- Repeat – Toggles the track repeat function through various positions – repeat all, repeat track, random (shuffle)
- U/SD – Toggles between USB and microSD cards when both are present in the media player
- Numeric Buttons – Entering a number will directly select a track by number. No enter key is necessary. To select track 17, enter 17 and wait and track 17 will start to play. If random (shuffle) is enabled, numeric entry will select random tracks.

Music on Hold

This output will feed music on your telephone system or PBX for people waiting to be answered. A dedicated input should be available on your telephone system. Please refer to a qualified technician if you can't identify this input.

Telephone Paging Input

This special TEL input will allow you to page in your PA system using your own telephone set or PBX system. At the end of the announcement, the system will return to its normal operation.

Remote Control Battery

The Remote Control uses a CR2025 button-cell battery. See the illustration below for the steps to remove the battery holder.

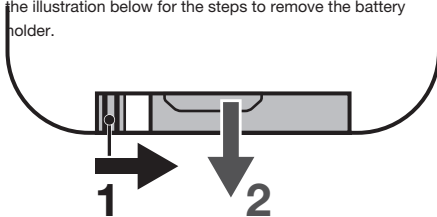

Connection Diagrams

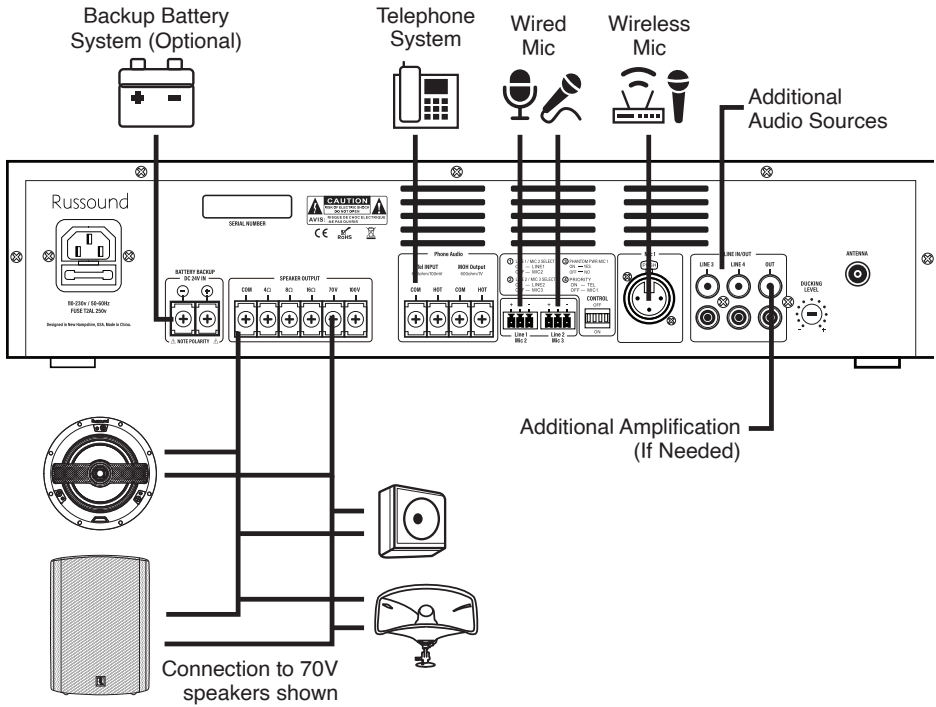

MixAmp-60 Specifications:

Rated Power Output	60W
Speaker Outputs	70V/100V/4Ω/8Ω/16Ω, RCA Line Out
Connectors:	Mic1 - Balanced XLR with phantom power Inputs 2-3: Mic/Line Switchable with Unbalanced 3-conductor Phoenix Connector Line Inputs 1-2: Stereo RCA
Frequency Response	60Hz-15kHz(±3dB)
S/N Ratio	Line ≥ 85dB, Mic≥ 72dB
THD	Less than 0.5%
Protection	short-circuit, clip, overload and high temp protection
Power Consumption	100W
Power Supply	110-230VAC, 50-60Hz
Dimension	320(W)×210(D)×90(H)mm
Weight	4.3kg

COMPLIANCE INFORMATION AND WARRANTY

COMPLIANCE INFORMATION

Warning: Changes or modifications to this unit not expressly approved by the party responsible for compliance could void the user's authority to operate the equipment.

NOTE: This equipment has been tested and found to comply with the limits for a Class B digital device, pursuant to Part 15 of the FCC Rules. These limits are designed to provide reasonable protection against harmful interference in a residential installation. This equipment generates, uses and can radiate radio frequency energy and, if not installed and used in accordance with the instructions, may cause harmful interference to radio communications.

However, there is no guarantee that interference will not occur in a particular installation. If this equipment does cause harmful interference to radio or television reception, which can be determined by turning the equipment off and on, the user is encouraged to try to correct the interference by one or more of the following measures:

Reorient or relocate the receiving antenna.

Increase the separation between the equipment and receiver.

Connect the equipment into an outlet on a circuit different from that to which the receiver is connected.

Consult the dealer or an experienced radio/TV technician for help.

FCC RF Radiation Exposure Statement Caution: To maintain compliance with the FCC's RF exposure guidelines, place the product at least 20cm from nearby persons.

To maintain compliance with the RF exposure guidelines, place the product at least 20cm from nearby persons.

Pour rester en conformité avec les consignes d'exposition aux RF, placez le produit à au moins 20 cm des personnes proches.

This device contains licence-exempt transmitter(s)/receiver(s) that comply with Innovation, Science and Economic Development Canada's licence-exempt RSS(S). Operation is subject to the following two conditions:

1. This device may not cause interference.
2. This device must accept any interference, including interference that may cause undesired operation of the device.

L'émetteur/récepteur exempt de licence contenu dans le présent appareil est conforme aux CNR d'Innovation, Sciences et Développement économique Canada applicables aux appareils radio exempts de licence. L'exploitation est autorisée aux deux conditions suivantes:

1. L'appareil ne doit pas produire de brouillage;
2. L'appareil doit accepter tout brouillage radioélectrique subi, même si le brouillage est susceptible d'en compromettre le fonctionnement.

LIMITED WARRANTY

Russound/FMP, Inc. warrants to the original retail purchaser that this product will be free of manufacturing defects in material and workmanship for the following periods ("Warranty Period") and subject to the limitations and exclusions set forth below:

Lifetime

Volume controls, in-wall and in-ceiling speakers, Flexbox speaker back boxes

Ten years from the date of purchase

Speaker selectors and impedance matching devices

Five years from the date of purchase

Landscape speakers, Outback™ speakers

Two years from the date of purchase

Multiroom controllers, keypads, source equipment, A-BUS devices, ComPoint devices, D-Series amplifiers, infrared products, 70V/100V amplifiers

One year from the date of purchase

P-Series amplifiers, touchscreens

Ninety days from the date of purchase

All B-Stock or factory-refurbished items

This Warranty is not transferable to subsequent purchasers/owners of the product.

This Warranty does not include service or parts to repair damage caused by improper use or handling, including but not limited to damage caused by accident, mishandling, improper installation, shipping damage, power surges,

lightning strikes, abuse, negligence, or normal wear and tear, or any defect caused by repair to the product by anyone other than Russound or Russound's authorized repair facility.

Certain Russound products may permit access to third-party content providers and/or may support third-party technologies such as specific codecs or file formats. Russound reserves the right to discontinue support and/or access to such third-party content or technologies at any time and for any reason. Russound makes no representations or warranties whatsoever regarding ongoing support for any such third-party content or technologies.

This Warranty does not cover reimbursement for the costs of removing and transporting the product for warranty service evaluation, re-installation, or installation of any replacement product provided under this Warranty.

To obtain warranty service, contact the authorized Russound dealer/installer where you purchased your product or take the unit to the nearest authorized Russound dealer. Proof of purchase must be provided – claims made without proof of purchase will not be covered under this Warranty. The authorized Russound dealer/installer will test the product and if necessary, make arrangements with Russound for service. If there are no authorized Russound dealers in your area, you must contact Russound to receive a factory Return Authorization Number and shipping instructions. Purchaser is responsible for any shipping and handling charges for shipping the product to Russound. DO NOT RETURN ANY UNIT WITHOUT FIRST RECEIVING WRITTEN AUTHORIZATION AND SHIPPING INSTRUCTIONS FROM RUSSOUND. ANY PRODUCTS RECEIVED WITHOUT FOLLOWING THIS PROCEDURE WILL BE REFUSED AND RETURNED UNOPENED.

Upon examination, Russound will, at its sole option and expense, repair or replace any product found to be defective. Russound will return the repaired or replaced unit to you via its usual shipping method from the Russound repair center to your address in the United States of America or Canada only. Any shipping costs for addresses outside of the United States or Canada or any expedited shipping charges requested by the purchaser shall be the responsibility of the purchaser. In the event that a particular product is no longer available and cannot be repaired effectively, Russound, at its sole option, may replace it with a different model of equal or greater value, or refund the original purchase price paid.

THE FOREGOING ARE YOUR EXCLUSIVE REMEDIES FOR BREACH OF WARRANTY.

This Warranty will be void if:

- the serial number on the product has been removed, tampered with, or defaced.
- the product was not purchased from an authorized dealer or reseller.

THE FOREGOING WARRANTIES ARE EXCLUSIVE AND IN LIEU OF ALL OTHER EXPRESSED AND IMPLIED WARRANTIES. RUSSOUND EXPRESSLY DISCLAIMS ALL SUCH OTHER WARRANTIES, INCLUDING BUT NOT LIMITED TO IMPLIED WARRANTIES OF MERCHANTABILITY, FITNESS FOR A PARTICULAR PURPOSE AND NON-INFRINGEMENT, WITH RESPECT TO THE PRODUCT. TO THE MAXIMUM EXTENT PERMITTED BY LAW, RUSSOUND SHALL NOT BE RESPONSIBLE FOR ANY INCIDENTAL OR CONSEQUENTIAL DAMAGES EXCEPT TO THE EXTENT PROVIDED (OR PROHIBITED) BY APPLICABLE LAW, EVEN IF IT HAS BEEN ADVISED OF THE POSSIBILITY OF SUCH DAMAGES.

Not with standing the above, if you qualify as a "consumer" under the Magnuson-Moss Warranty Act, or applicable state laws, then you may be entitled to any implied warranties allowed by law for the Warranty Period. Further, some states do not allow limitations on how long an implied warranty lasts or allow the exclusion or limitation of consequential damages, so such limitations may not apply to you. This warranty gives you specific legal rights, and you may also have other rights which vary from state to state.

For the name of your nearest authorized Russound dealer, contact: Russound, 1 Forbes Road, Newmarket, NH 03857, or call 1 (603) 659-5170. Please be advised that Russound products are only sold via the Internet through a select group of authorized Internet dealers. These are listed at www.russound.com. Products offered on the Internet through unauthorized Internet dealers are not covered by this warranty and may be either:

- 1) goods acquired on a secondary or grey market
- 2) counterfeit or stolen goods
- 3) damaged, or defective goods

Please fill in your product information and retain this for your records. You may also submit your warranty registration information online on www.russound.com/warranty-registration, but you must still retain all proof of purchase information should warranty service ever be required.

Model _____

Serial No. _____

Purchase Date _____

ATTENTION: TO OUR VALUED CUSTOMERS:

To ensure that consumers obtain quality pre-sale and after-sale support and service, Russound products are sold exclusively through authorized dealers. This Warranty is **VOID** if the products have been purchased from an unauthorized dealer.

a sound relationship
Russound

MIXAMP-60

70V Mixer Amplifier with Media Player

Built-in FM Tuner, Bluetooth, USB/SD Audio

©2021 Russound/FMP, Inc. All rights reserved.
All trademarks are the property of their respective owners.
Specifications are subject to change without notice.

Russound
1 Forbes Road, Newmarket, NH 03857
Telephone: 603.659.5170
Email: tech@russound.com www.russound.com

5.26.21 Rev. 8