

This drawing is the property of Rev-A-Shelf (RAS) and is disclosed in confidence to the extent its subject matter is original to RAS. Any vendor receiving this drawing from RAS shall hold and use this drawing for the sole benefit of RAS and shall not disclose it to, or use or reproduce it for any third party, or perform any act adverse to the interest of RAS with respect to this drawing without the express written permission of RAS. Vendors shall not revise any physical, dimensional or performance characteristic unless authorized by Rev-A-Shelf Engineering.

REV.	DATE	BY	DESCRIPTION OF CHANGE

AMERICAN PROJECTION		BY	DATE	REV-A-SHELF, INC.	
INCH [MM]		DRAWN	JOE	21.04.26	
				SIZE	TWO-TIER 15° BLIND CORNER
				B	OPTIMIZER W/ SOFT CLOSE
TOLERANCES MAT. (WOOD) .XX ± .03 [.8mm] (OTHER) .XX ± .02 [.5mm] (ALL) .XXX ± .005 [.13mm] FRACTIONS ± 1/32 [.8mm]		MATERIAL	DRAWING NO.	SCALE	
		FINISH	PART NO.	1:10	
			53PSP-15SC-GR	SHEET OF	
				1 2	

CUSTOMER DRAWING

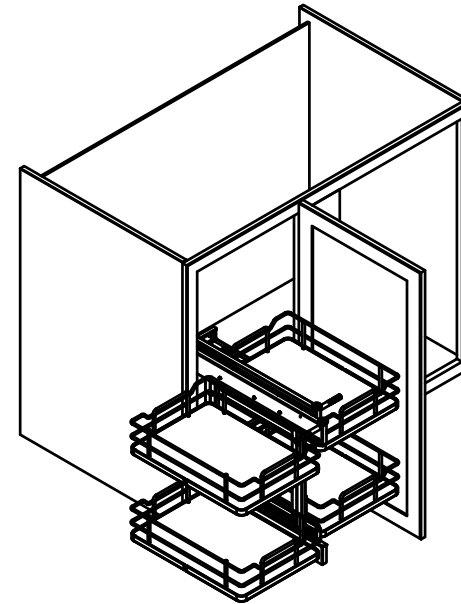
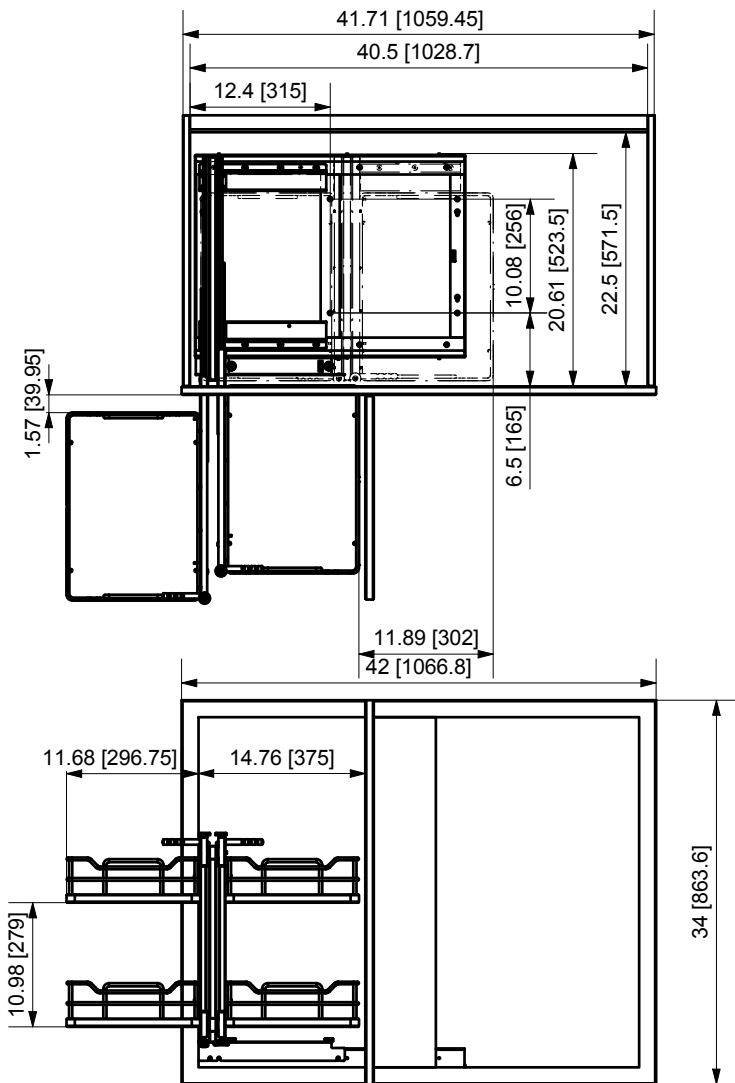

PART DIMENSIONS		
	MIN	MAX
WIDTH	26.4[670.5]	37.76[959]
DEPTH	20.40[518.2]	39.92[1014]
HEIGHT	21[533]	21[533]
WEIGHT		
DIAMETER		
RADIUS		
CONTAINER		
CAPACITY		
CONTAINER UOM		

MIN CABINET OPENING	
WIDTH	15.00[381]
DEPTH	21.66[550]
HEIGHT	22.00[559]

PRODUCT MAX WEIGHT RATING

SLIDE SPECIFICATIONS				
SLIDE TYPE	BALL BEARING	SLIDE EXTENSION	19.69 [500]	MAX WEIGHT RATING
SLIDE CLOSING	SOFT CLOSE	SLIDE LENGTH	19.76 [502]	
SLIDE MOUNTING	FLOOR	SLIDE FINISH	ZINC	100LB

CUSTOMER DRAWING

This drawing is the property of Rev-A-Shelf (RAS) and is disclosed in confidence to the extent its subject matter is original to RAS. Any vendor receiving this drawing from RAS shall hold and use this drawing for the sole benefit of RAS and shall not disclose it to, or use or reproduce it for any third party, or perform any act adverse to the interest of RAS with respect to this drawing without the express written permission of RAS. Vendors shall not revise any physical, dimensional or performance characteristic unless authorized by Rev-A-Shelf Engineering.

REV.	DATE	BY	DESCRIPTION OF CHANGE

AMERICAN PROJECTION		BY	DATE		
		DRAWN	JOE 21.04.26		
TOLERANCES MAT. (WOOD) .XX ± .03 [.8mm] (OTHER) .XX ± .02 [.5mm] (ALL) .XXX ± .005 [.13 mm] FRACTIONS ± 1/32 [.8 mm]		MATERIAL FINISH		SCALE 1:17	SHEET OF 2 2
SIZE TWO-TIER 15" BLIND CORNER B OPTIMIZER W/ SOFT CLOSE		DRAWING NO. PART NO. 53PSP-15SC-GR			