

SIDES	BOTTOM
Material: Steel- $\varnothing 0.205''$ -(C1008-C1018) Zinc Plated	

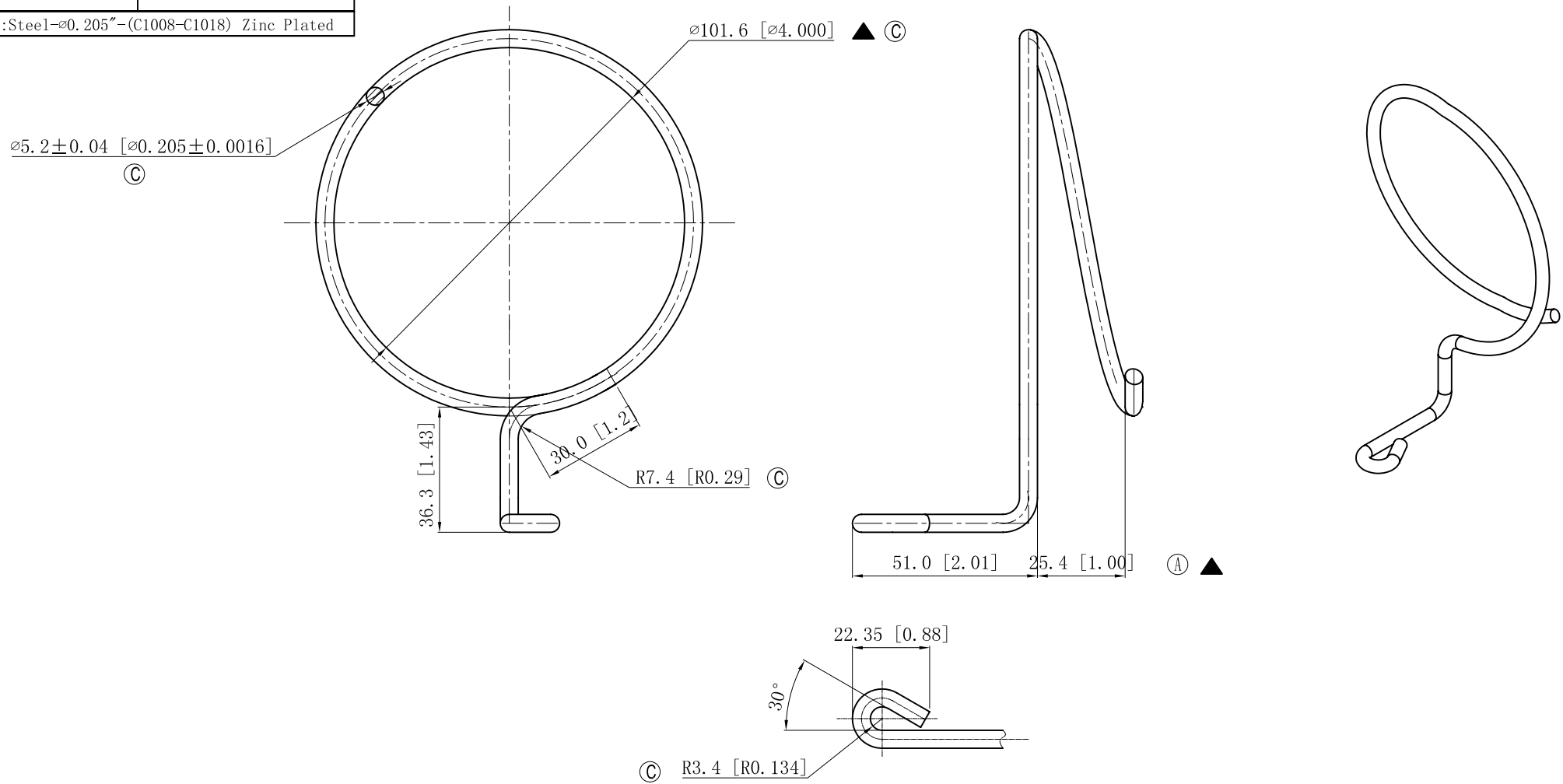

This data sheet is for reference only .GARVIN INDUSTRIES reserves the right to make changes to the design without prior notice.

DESCRIPTION
Patent #: Pat. US 6,364,266 B1
TRADE REFERENCE TERMS

STANDARD PACKING
100 PCS

TITLE			REV
QUICK-SCREW BRIDLE RINGS			
SIZE	DWG NO.	BR-400NP	D
A4		DATA SHEET	