

SIDES	BOTTOM

Material: Steel- $\varnothing 0.204$ "-(C1008-C1018) Zinc Plated

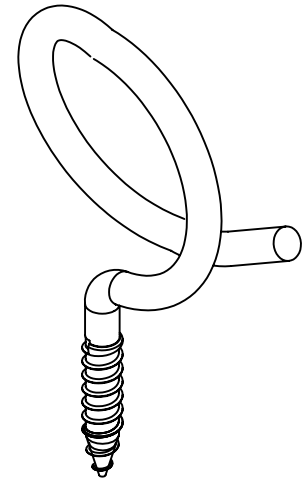
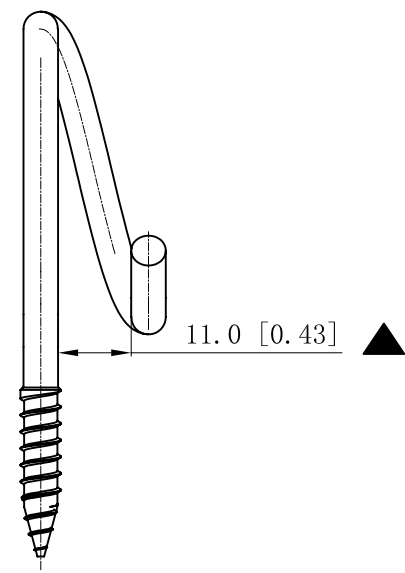
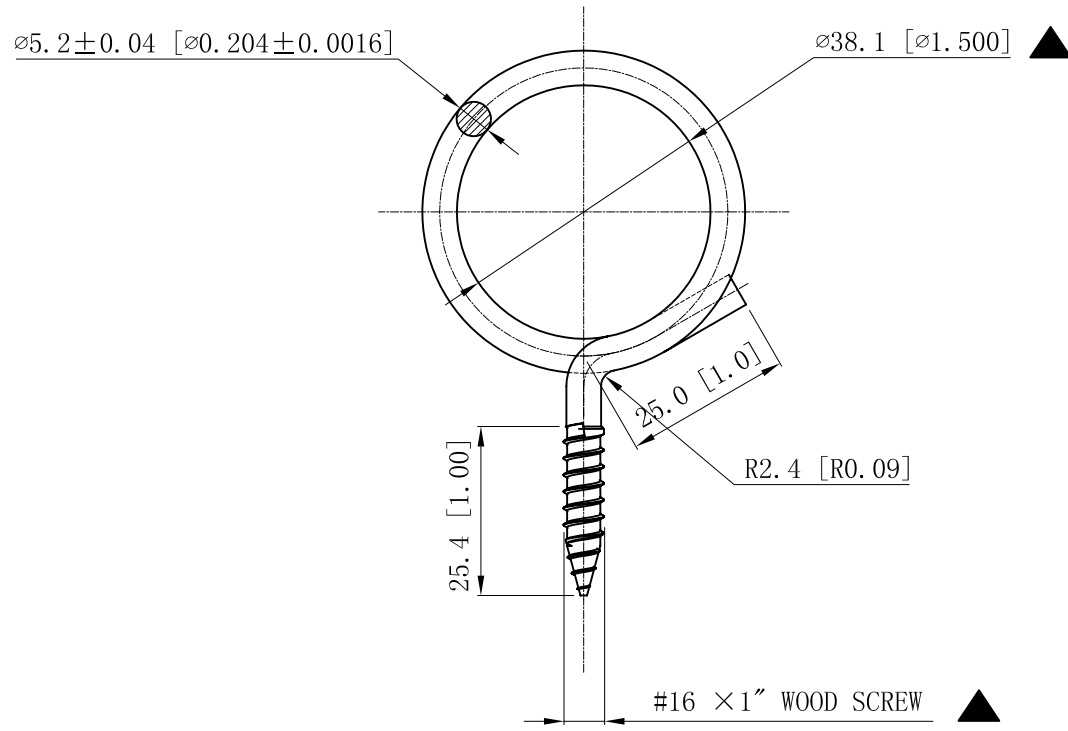

DESCRIPTION
TRADE REFERENCE TERMS

STANDARD PACKING
100 PCS

This data sheet is for reference only .GARVIN INDUSTRIES reserves the right to make changes to the design without prior notice.

<b>GARVIN INDUSTRIES</b>		
WOOD-SCREW BRIDLE RINGS		
SIZE A4	DWG NO. BR-150-WS	REV B
DATA SHEET		