

# GLASS DOOR MERCHANDISER FREEZERS

MODEL:  MVMF12B



MVMF12B

Maxx Cold V-Series Glass Door Merchandisers are designed for durability and visual appeal to display your product. The glass door merchandisers are energy efficient and effective at displaying product at the right temperature to preserve freshness and prolong shelf life. Simple-to-use, programmable solid-state digital controls deliver accurate temperature regulation.

## FEATURES AND CONSTRUCTION

- Constructed of a powder coated steel exterior and powder coated aluminum interior
- Triple pane heated & insulated glass door
- Interior LED lighting
- Bottom mounted compressor
- Three (3) adjustable heavy-duty PE-coated wire shelves
- Four (4) rollers (2 with leveling feet)
- Digital controls with LED temperature display
- Automatic defrost system
- Provided with lock and key set for security
- Illuminated top panel for advertising/promoting products
- Equipped with integrated condensate evaporator therefore no drain line connection is needed

## ELECTRIC

115V / 60Hz / 1Ph  
 (230V / 50-60Hz / 1Ph is available as an option)  
 6' (2m) NEMA 5-15P cord set included

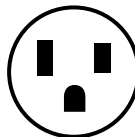

NEMA 5-15P

## 3RD PARTY APPROVALS



Intertek

Certified to ANSI NSF 7



Intertek

Certified to ANSI UL 471



Zero Ozone Depletion Potential

## NOMINAL STORAGE CAPACITY

MVMF12B ..... 12 Cu Ft (340 L)

## TEMPERATURE

Holding temperature ..... 0°F to 10°F (-18°C to -12°C)

- Oversized refrigeration system delivers optimum storage temperature and rapid temperature recovery

## MAXX COLD WARRANTY (USA / CANADA)

1 Year Compressor Only Warranty; 6 Months Parts & Labor

For more information, contact:

TechnicalServices@TheLegacyCompanies.com or 877.368.2797

MVMF12B

FRONT VIEW

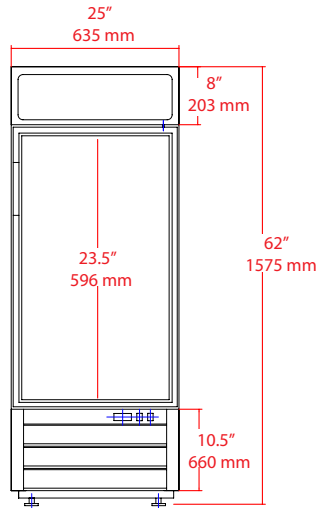

TOP VIEW

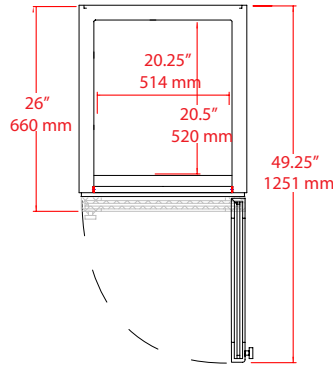

BACKLIT DISPLAY PANEL

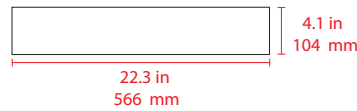

MODEL	EXTERNAL DIMENSIONS	INTERNAL DIMENSIONS	NOMINAL CAPACITY	HOLDING TEMPERATURE RANGE	AMP DRAW	UNIT WEIGHT	REFRIGERANT AND CHARGE SIZE	DOORS / SHELVES	ELECTRICAL
MVMF12B	25" x 26" x 62" (635 x 660 x 1575 mm)	20.25" x 20.5" x 23.5" (514 x 520 x 596 mm)	12 Cu Ft (340 L)	0°F to 10°F (-18°C to -12°C)	5.0A	221 lbs (100 kg)	R-290A 3.7 oz (105 g)	1 / 3	115V / 60Hz / 1Ph

**INSTALLATION**

- Units are equipped with roller wheels and leveling feet. Swivel caster wheels are an available option for increased mobility.