

Assembly Instructions

Swivel Chair

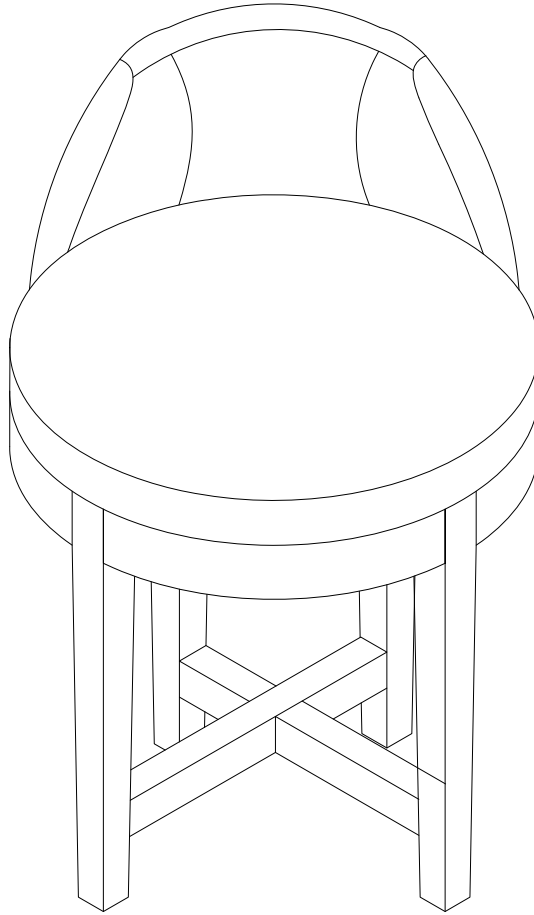

Please provide the following information when contacting for parts or questions: the name of the company you purchased from, the tracking number of the original package, and the original order date.

We offer free replacements for 1 year (purchase verification required). This replacement policy does not cover used/previously returned product or products sold by unauthorized third party vendors.

ASSEMBLY INSTRUCTIONS - IMPORTANT

Carefully unpack & identify each component before attempting to assemble. Refer to parts list. Please take care when assembling the unit and always set the parts on a clean, soft surface. If you require any assistance with assembly, parts, please call the company you place order with or please email to: service@eleganthf.net.

INSTRUCCIONES PARA ARMAR - IMPORTANTE :

Desempaque cuidadosamente e identifique cada componente antes de tratar de empezar su ensambladura. Verifique la lista de partes. Por favor tenga cuidado cuando arme la unidad y siempre coloque las piezas sobre una superficie plana, suave y limpia. Si necesita ayuda con el armado, envíe un correo electrónico a service@eleganthf.net.

DIRECTIVES DE MONTAGE-IMPORTANT:

Avant de commencer l'assemblage, déballez délicatement toutes les pièces et repérez-les sur la liste des pièces. Procédez avec soins durant l'assemblage et posez toujours les pièces sur une surface propre, douce et lisse. Si vous plait e-mail à service@eleganthf.net.

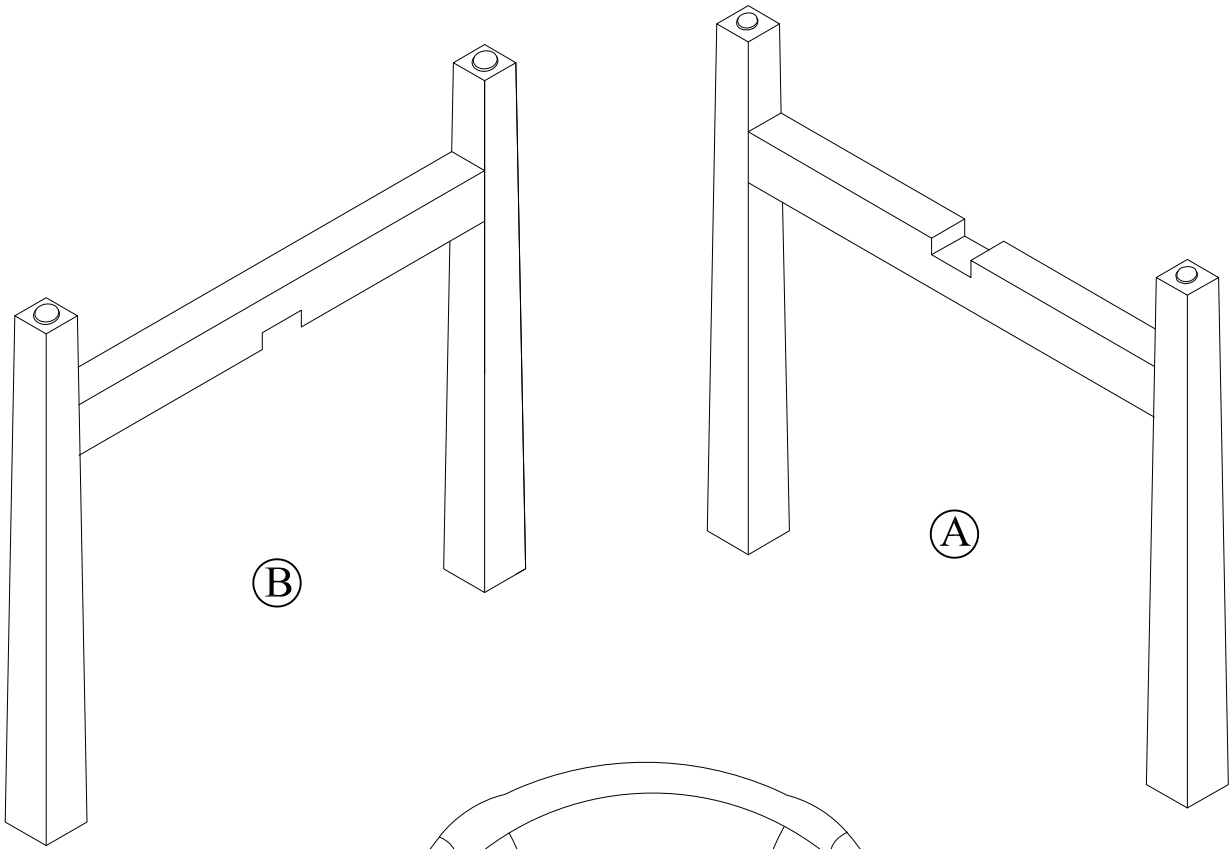

Ⓑ

Ⓐ

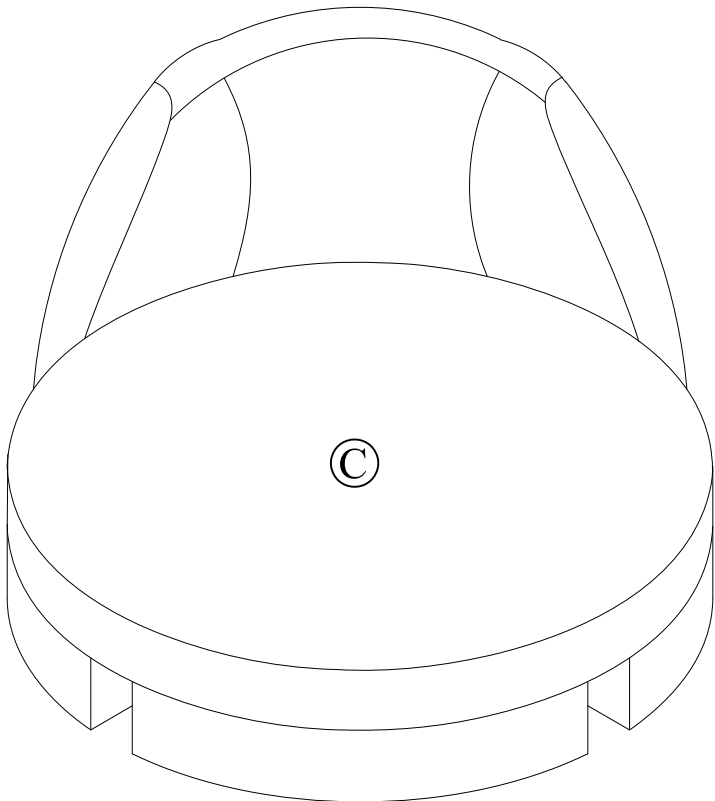



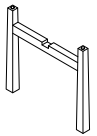
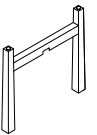
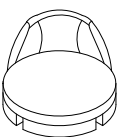

Ⓒ

COMPONENTS

| PART | FIGURE | DESCRIPTION | QTY | PART | FIGURE | DESCRIPTION | QTY |
|------|---|-------------|-----|------|--------|-------------|-----|
| A |  | UPPER LEG | 1PC | | | | |
| B |  | LOWER LEG | 1PC | | | | |
| C |  | CUSHION | 1PC | | | | |
| | | | | | | | |
| | | | | | | | |
| | | | | | | | |
| | | | | | | | |
| | | | | | | | |
| | | | | | | | |
| | | | | | | | |
| | | | | | | | |
| | | | | | | | |
| | | | | | | | |
| | | | | | | | |
| | | | | | | | |
| | | | | | | | |
| | | | | | | | |
| | | | | | | | |
| | | | | | | | |
| | | | | | | | |

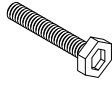
HARDWARE & TOOLS

| PART | FIGURE | DESCRIPTION | QTY | PART | FIGURE | DESCRIPTION | QTY |
|------|---|--------------------|------|------|--------|-------------|-----|
| 1 |  | WASHER | 8PCS | | | | |
| 2 |  | SPRING LOCK WASHER | 8PCS | | | | |
| 3 |  | ALLEN BOLT | 8PCS | | | | |
| 4 |  | ALLEN WRENCH | 1 PC | | | | |
| | | | | | | | |
| | | | | | | | |
| | | | | | | | |
| | | | | | | | |

TOOL NEEDED:

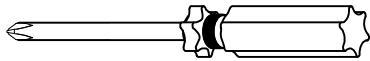

**PHILIPS SCREWDRIVER REQUIRED
- NOT INCLUDED**

SUGGESTION:

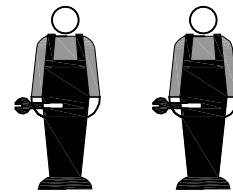

TWO PEOPLE FOR ASSEMBLING



WARNINGS:

1. DO NOT LET ANY SHARP OBJECTS TOUCH OR RUB THE SURFACE OF THE PRODUCT.
2. WHEN ASSEMBLING, DO NOT LET CHILDREN PLAY AROUND THE WORKING AREA.
3. PLEASE CONFIRM ALL PARTS ARE CORRECT BEFORE STARTING THE ASSEMBLY PROCESS.
4. DO NOT TIGHTEN ALL BOLTS AND SCREWS COMPLETELY UNTIL THE ENTIRE UNIT HAS BEEN ASSEMBLED AND SET UP.

1

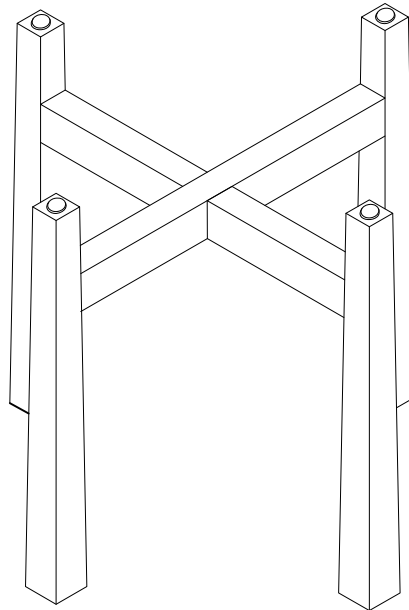
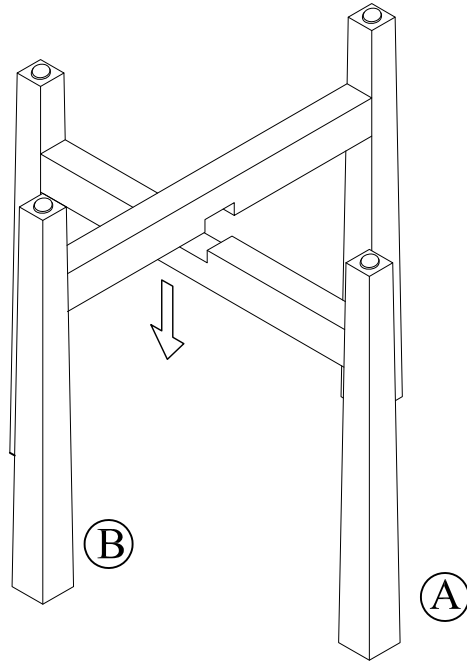

STEP 1:

1. Connect the Upper Leg A and the Lower Leg B, and aimed the groove on the Upper Leg A and Lower Leg B.

2

1

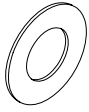

8pcs

2



8pcs

3

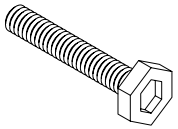

8pcs

4

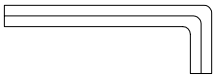

1 pc

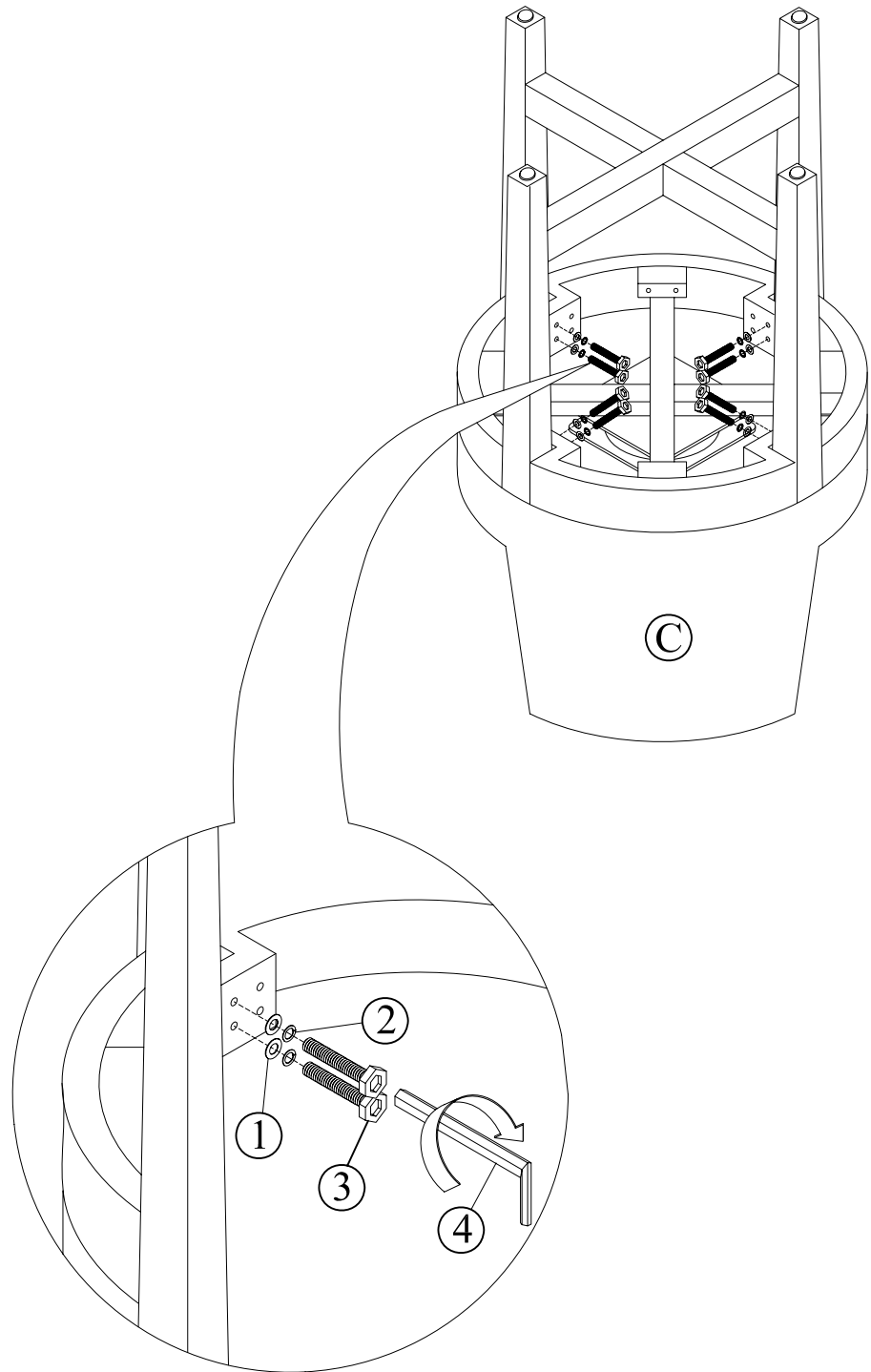

STEP 2:

1. Insert the Upper Leg A and the Lower Leg B into the groove of the Cushion C.
2. Insert the Allen Bolt #3 into the hole on the Cushion C, and by order to pass through the Spring Lock Washer #2 and the Washer #1.
3. Tighten the Allen Bolt #3 with the Allen Wrench #4.

California Proposition 65 Warning

WARNING: This product may contain chemicals known to the state of California to cause cancer, and birth defects or other reproductive harm.

ADVERTENCIA: Este producto puede contener sustancias químicas conocidas en el estado de California como causantes de cáncer, defectos de nacimiento u otros daños reproductivos.

For more information:
<https://oehha.ca.gov/proposition-65>