

This document, including the design, configuration and mechanical features revealed herein are the sole, confidential and proprietary property of TRU Corporation. Reproduction or use thereof, in whole or part, is prohibited without the prior written consent of TRU Corporation.

REV.	DESCRIPTION	DATE	APPROVED
-	ORIGINAL ISSUE	06/01/11	TRC

ENGINEERING DATA

**ELECTRICAL:**

IMPEDANCE- 50 OHMS NOMINAL  
 FREQUENCY RANGE- DC TO 18 GHZ  
 VSWR MAX- 1.10 :1

**MECHANICAL:**

INTERFACE- PER MIL-STD-348

**MATERIAL:**

CONTACTS- BRASS & BERYLLIUM COPPER  
 BODIES- STAINLESS STEEL & BRASS  
 INSULATOR- NORYL

**FINISH:**

CONTACTS- GOLD PLATED  
 BODIES- GOLD PLATED

**ENVIROMENTAL:**

TEMPERATURE: 0° C to +85° C

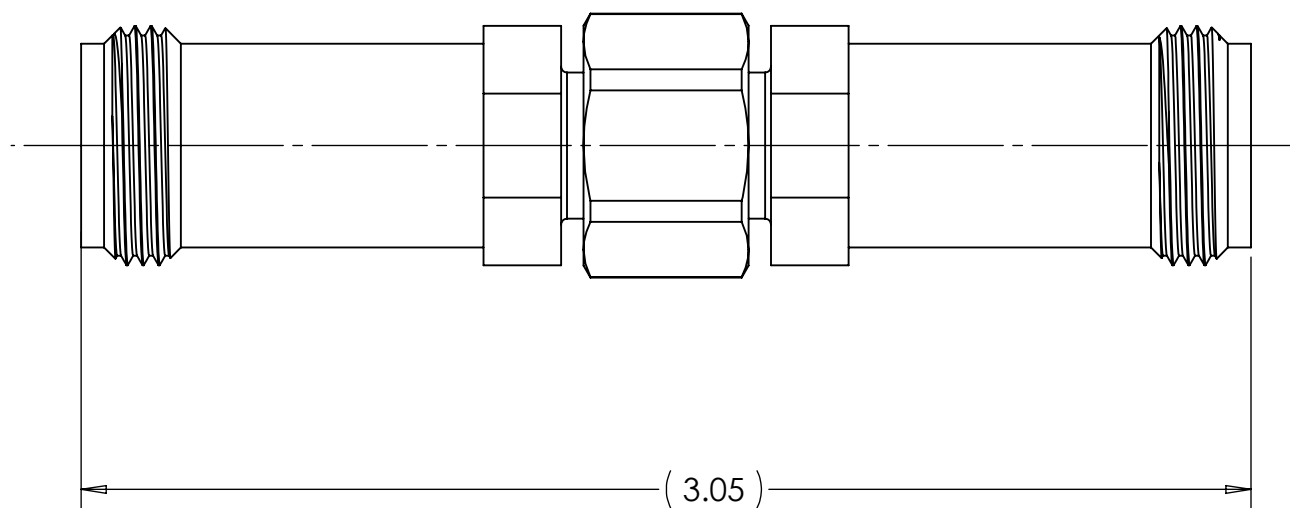
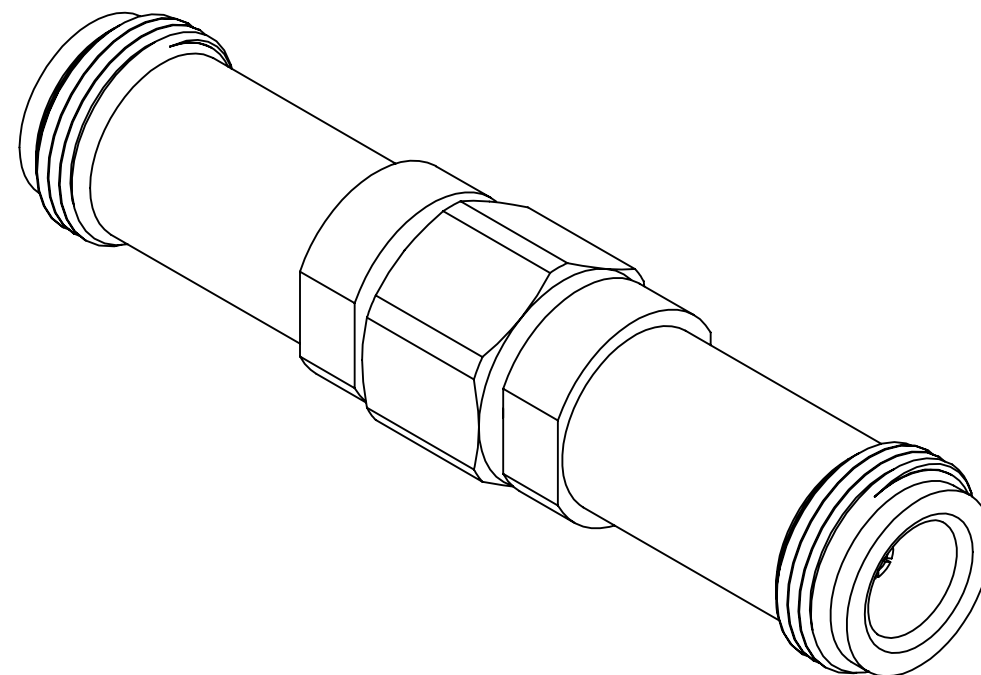

**NOTES:**

- UNLESS OTHERWISE SPECIFIED; ALL DIMENSIONS ARE REFERENCE ONLY.

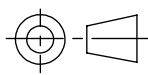
MATERIAL	DO NOT SCALE DRAWING	DRAWN JEF	DATE 5-10-11	 <b>TRU CORPORATION</b> 245 LYNNFIELD STREET, PEABODY, MA 01960 The Custom Interconnect Leader™
	UNLESS OTHERWISE SPECIFIED: DIMENSIONS ARE IN INCHES	ENG APPR. TRC	DATE 06/01/11	
COMMENTS:	TOLERANCES: FRACTIONS: ±1/64 .XX : ±.01 .XXX: ±.005 ANGLES: ±1/2° MACHINED SURFACES: 63/√	MFG APPR.	DATE	TITLE: CONNECTOR, CO-AXIAL N(f) to N(f) ADAPTER
		OTHER APPR. AM	DATE 05/17/11	
surface area: sq inch	weight: lbs	THIRD ANGLE PROJECTION 		SIZE <b>B</b> DWG. NO. TRU-11100-GGX REV - CAGE CODE: 92180 SCALE: 2:1 SHEET 1 OF 1