



Project Name: _____

Location: _____

Item #: _____ Qty: _____

Model: _____

NARROW DEPTH BEER DISPENSERS

MODEL: USBD-4824/2 USBD-6024/2 USBD-7224/2



USBD-4824/2



USBD-6024/2



USBD-7224/2

U-Star's 24" Narrow Depth Beer Dispensers are an easy way to offer up cold and refreshing draft beers to your patrons for work areas with limited space. These units feature stainless steel tap tower(s) that allow you to fill pint glasses and pitchers straight from the keg. Available in a wide range of sizes that can hold a number of different sized keg barrels both for use and storage. Adjustable shelves are also included for optional bottle or can storage. These units have solid black vinyl locking doors that conceal the contents inside and keep them secure after hours. The thick stainless steel top and built-in drip trays allow for easy clean-up. These models are ETL Listed, ETL Sanitation and backed by a 2 year warranty on parts and labor and a 5 year warranty on the compressor.

FEATURES AND CONSTRUCTION

- Heavy duty, wear resistant laminated black vinyl front and sides
- All stainless steel countertop, tap towers and drip trays
- Narrow 24" depth is great for work areas with limited space
- Interior is all stainless steel floor and inner walls
- 3" diameter stainless steel insulated beer columns
- Environmentally-friendly R290 refrigerant
- Side mounted compressor optimizes interior space
- Foamed-in-place polyurethane high density cell insulation throughout the entire cabinet

ELECTRIC

115V / 60Hz / 1Ph
7' (2.1m) NEMA 5-15P cord set included

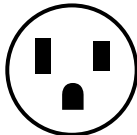

NEMA 5-15P

3RD PARTY APPROVALS



Intertek



Intertek



U-STAR WARRANTY

U-Star beer dispensers are warrantied for 2 years on parts & labor, 5 year warranty on the compressor.

For warranty service on these products please call National Service America (NSA) at 1-877-672-7740.

NOMINAL STORAGE CAPACITY

USB-4824/2	11.8 Cu Ft (334 L)
USB-6024/2	15.8 Cu Ft (447 L)
USB-7224/2	19.6 Cu Ft (555 L)

TEMPERATURE

Holding Temperature..... 33°F to 38°F (1°C to 3.3°C)

- These models are designed to operate in an environment where temperature and humidity do not exceed 75°F (24°C) and 55% relative humidity

USBD-4824/2

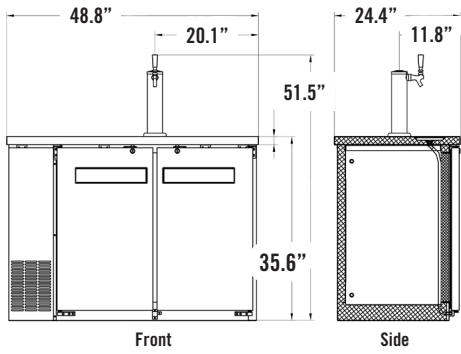

USBD-6024/2

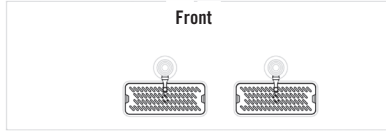
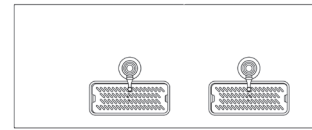
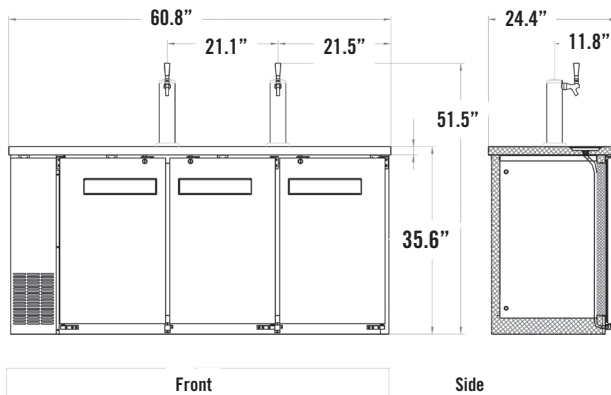
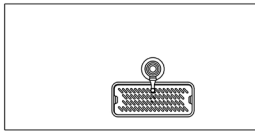
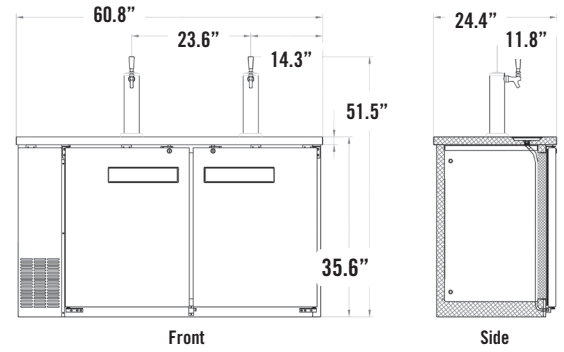

USBD-7224/2

Model	USBD-4824/2	USBD-6024/2	USBD-7224/2
Doors	2	2	3
Taps Towers	1	2	2
Kegs (Half Barrels)	2	2	3
Net Volume (Cu. Ft.)	11.8 Cu. Ft.	15.8 Cu. Ft.	19.6 Cu. Ft.
Overall Dimensions (in)	48.75" × 24.5" × 36.25"	60.75" × 24.5" × 36.25"	72.75" × 24.5" × 36.25"
Interior Dimensions (in)	36" × 18.5" × 29"	48" × 18.5" × 29"	60" × 18.5" × 29"
Refrigerant	R290	R290	R290
Horsepower	1/5	1/5	1/4
Voltage/Hertz/Phase	115/60/1	115/60/1	115/60/1
Amps	3	3	4
Net Weight (lbs)	187 lbs	247 lbs	309 lbs
Gross Weight (lbs)	231 lbs	291 lbs	353 lbs
Shipping Dimensions (in)	51" × 27.5" × 41.7"	62" × 27.5" × 41.7"	75" × 27.5" × 41.7"