

Dimensional Data (inches and [ mm ]) are Subject to Manufacturing Tolerances and Change Without Notice

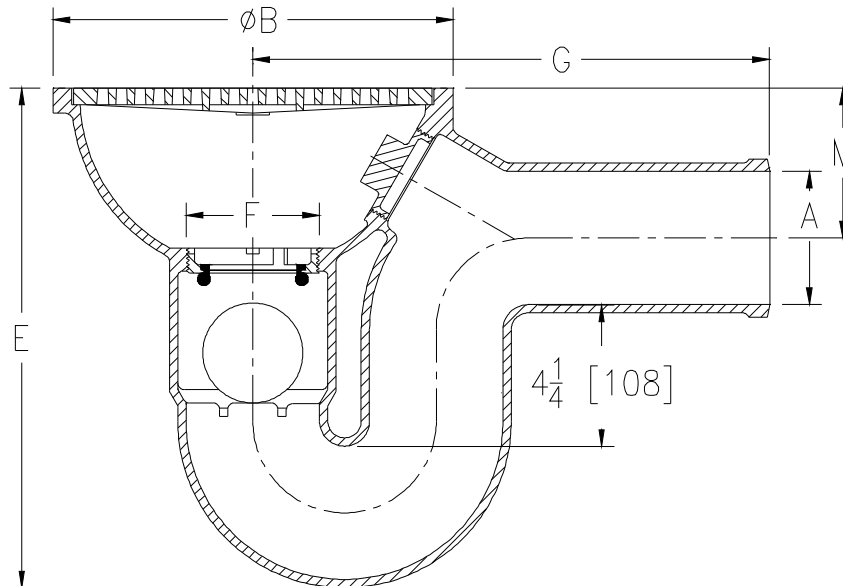

Dimensions In Inches [mm]					Approx. Wt. Lbs. [kg]	Grate Open Area Sq. In. [cm <sup>2</sup> ]
A Pipe Size	F N.P.T.	B	G	M		
2 [51]	2 [51]	8-1/4 [210]	10-1/8 [257]	3-1/2 [89]	17 [7]	13 [84]
3 [76]	3-1/2 [89]	10-1/2 [267]	12-1/2 [318]	4 [102]	36 [16]	19 [123]
4 [102]	3-1/2 [89]	12 [305]	15-1/2 [394]	4-1/2 [114]	54 [24]	40 [258]

**ENGINEERING SPECIFICATION ZURN Z742**

8", 10" or 12" [203mm, 254mm or 305mm] Diameter top drain, Dura-Coated cast iron body with integral double wall trap and side outlet, with ball float type backwater valve, internal bronze cleanout and light-duty loose slotted grate.

**OPTIONS** (Check/specify appropriate options)

PIPE SIZE	(Specify size/type) OUTLET	'E' BODY HT. DIM.
2 [51]	_____ SP Spigot	10-3/4 [273]
3 [76]	_____ SP Spigot	12-3/4 [324]
4 [102]	_____ SP Spigot	15 [381]

**PREFIXES**

- \_\_\_\_\_ Z D.C.C.I. Body and Top\*
- \_\_\_\_\_ ZB D.C.C.I. Body with Polished Bronze Top (Add 3/16 [5] to 'E' Dim.)
- \_\_\_\_\_ ZN D.C.C.I. Body with Polished Nickel Bronze Top (Add 3/16 [5] to 'E' Dim.)

**SUFFIXES**

- \_\_\_\_\_ -DG Duresist Grate
- \_\_\_\_\_ -G Galvanized Cast Iron
- \_\_\_\_\_ -LV (Less) Backwater Valve
- \_\_\_\_\_ -TS Top Secured with Slotted Screws
- \_\_\_\_\_ -VP Vandal-Proof Secured Top

\* Regularly furnished unless otherwise specified.