

INSTALLATION INSTRUCTIONS FOR CONCEALED CLOSET AND URINAL FLUSHOMETERS



Model 140



Model 195

Concealed Closet Flushometer – 1-1/2" Exposed Back Spud

MODEL 140
MODEL 154

Concealed Closet Flushometer – 1-1/2" Exposed Top Spud

MODEL 142
MODEL 153

Concealed Closet Flushometer – 1-1/2" Back Spud

MODEL 143
MODEL 144
MODEL 150
MODEL 152

Concealed Urinal Flushometer – Back Spud

MODEL 190
MODEL 195

Concealed Urinal Flushometer – Exposed Top Spud

MODEL 192
MODEL 197

LIMITED WARRANTY

Unless otherwise noted, Sloan Valve Company warrants this product, manufactured and sold for commercial or industrial uses, to be free from defects in material and workmanship for a period of three (3) years (one (1) year for special finishes, SF faucets, PWT electronics and 30 days for PWT software) from date of first purchase. During this period, Sloan Valve Company will, at its option, repair, replace, or refund the purchase price of any product which fails to conform with this warranty under normal use and service. This shall be the sole and exclusive remedy under this warranty. Products must be returned to Sloan Valve Company, at customer's cost. No claims will be allowed for labor, transportation or other costs. This warranty extends only to persons or organizations who purchase Sloan Valve Company's products directly from Sloan Valve Company for purpose of resale. This warranty does not cover the life of the batteries.

THERE ARE NO WARRANTIES WHICH EXTEND BEYOND THE DESCRIPTION ON THE FACE HEREOF. IN NO EVENT IS SLOAN VALVE COMPANY RESPONSIBLE FOR ANY CONSEQUENTIAL DAMAGES OF ANY MEASURE WHATSOEVER.

PRIOR TO INSTALLATION

Check to make certain that the "L" dimension shown on the flushometer package is correct for your application. Determine the "L" dimension for your application by using the following formula:

"L" dimension = Wall Thickness (To Nearest Whole Inch) + 2-3/4"

Prior to installing a concealed flushometer, perform the following functions as illustrated in the Rough-in Diagrams on Pages 2 and 3.

- Bore a 1-1/2" (38 mm) hole in wall for Actuator.
- Bore a 2" (51 mm) [1" (25 mm) for Model 197 only] hole in wall for piping, if required.
- Install closet or urinal fixture.
- Install 1-1/2" (38 mm) drain line (NOT supplied by Sloan).
- Install water supply line. Note: Concealed valves are supplied with double handle opening to allow for installation of Control Stop on either the left or right side of the valve (refer to illustration in Step 4).

IMPORTANT:

- **INSTALL ALL PLUMBING IN ACCORDANCE WITH APPLICABLE CODES AND REGULATIONS.**
- **WATER SUPPLY LINES MUST BE SIZED TO PROVIDE AN ADEQUATE VOLUME OF WATER FOR EACH FIXTURE.**
- **FLUSH ALL WATER LINES PRIOR TO MAKING CONNECTIONS.**

Sloan's flushometers are designed to operate with 10 to 100 psi (69 to 689 kPa) of water pressure. **THE MINIMUM PRESSURE REQUIRED TO THE VALVE IS DETERMINED BY THE TYPE OF FIXTURE SELECTED.** Consult fixture manufacturer for minimum pressure requirements.

Most Low Consumption water closets (1.6 gpf/6.0 Lpf) require a minimum flowing pressure of 25 psi (172 kPa).

!!! IMPORTANT !!!

WITH THE EXCEPTION OF CONTROL STOP INLET, DO NOT USE PIPE THREAD SEALANT OR PLUMBING GREASE ON VALVE COMPONENTS OR COUPLINGS!

TOOLS REQUIRED FOR INSTALLATION

- Sloan A-50 Super-Wrench™, Sloan A-109 Plier Wrench or smooth jawed spud wrench
- Drill to bore 1½" (38 mm) and/or 2" (51 mm) hole(s) in wall (see rough-in)

ROUGH-IN

MODEL 140

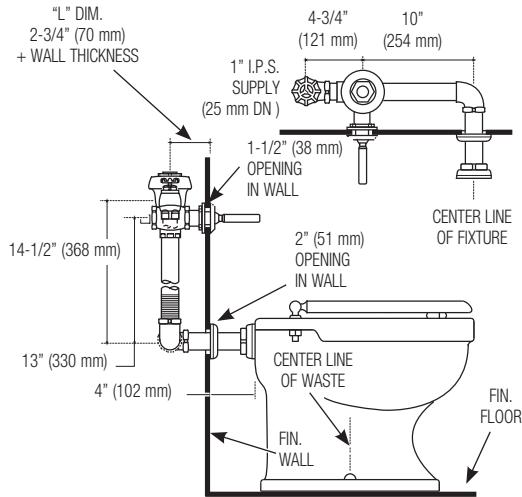

MODEL 142

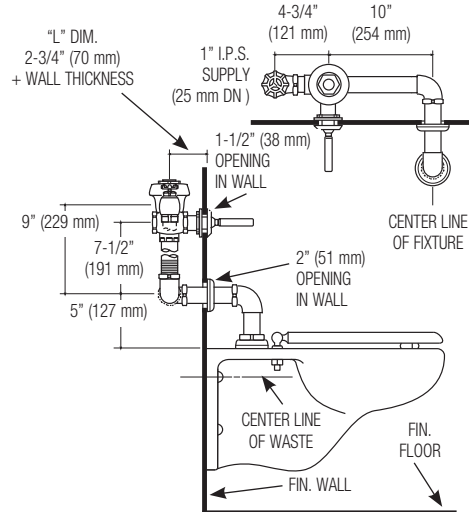

MODELS 143/144

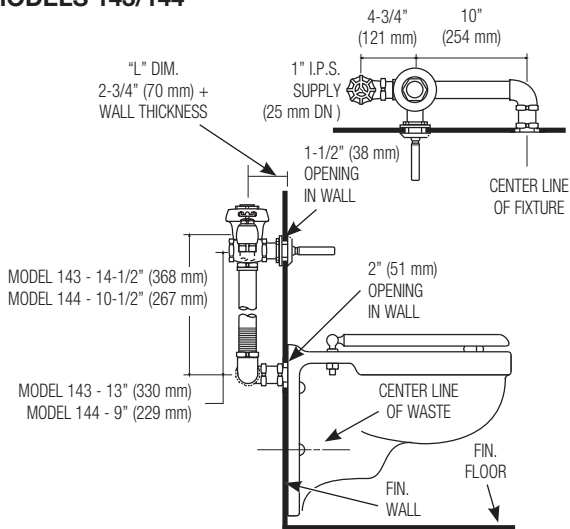

MODEL 152

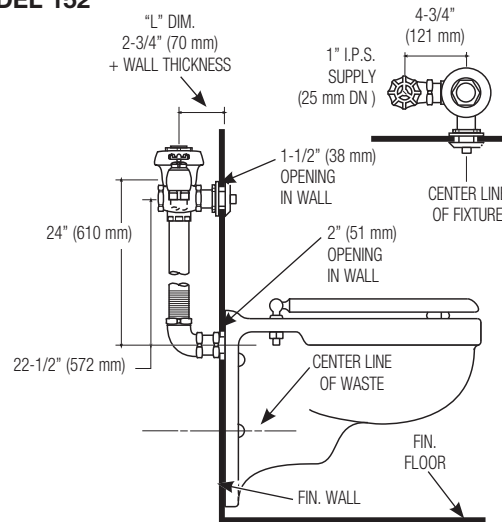

MODEL 153

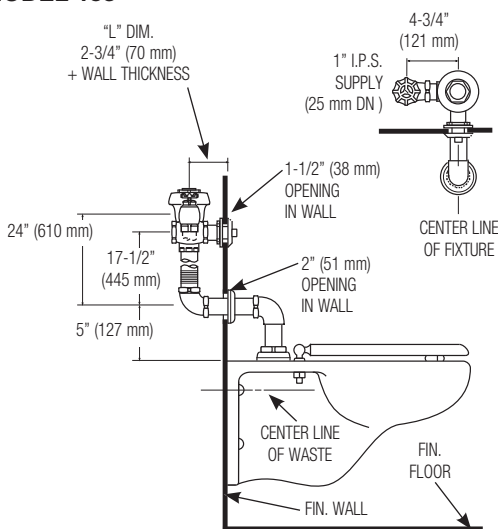

MODEL 154

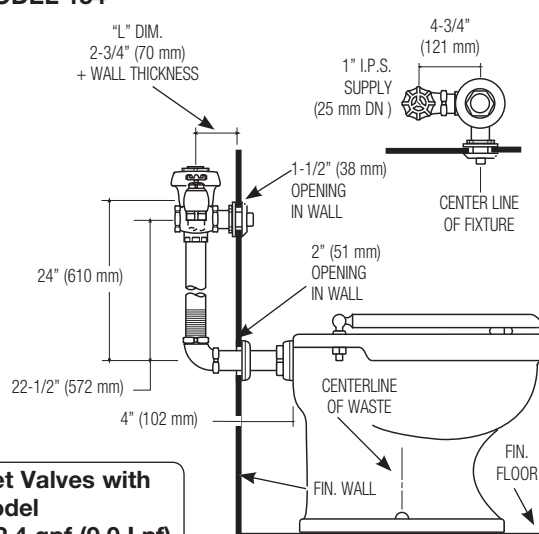

**NOTE: Water Closet Valves with
"-2.4" Model
Designation Deliver 2.4 gpf (9.0 Lpf)**

!!! IMPORTANT !!!

WITH THE EXCEPTION OF THE CONTROL STOP INLET, DO NOT USE PIPE THREAD SEALANT OR PLUMBING GREASE ON VALVE COMPONENTS OR COUPLINGS.



!!! IMPORTANT !!!

THIS PRODUCT CONTAINS MECHANICAL AND/OR ELECTRICAL COMPONENTS THAT ARE SUBJECT TO NORMAL WEAR. THESE COMPONENTS SHOULD BE CHECKED ON A REGULAR BASIS AND REPLACED AS NEEDED TO MAINTAIN THE VALVE'S PERFORMANCE.

ROUGH-IN (CONTINUED)

MODEL 190

NOTE: Requires 1" I.P.S. (25 mm DN) SUPPLY

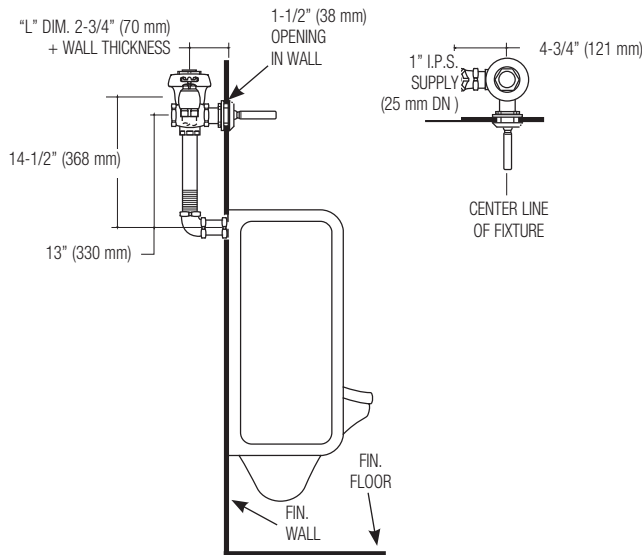

MODEL 192

NOTE: Requires 1" I.P.S. (25 mm DN) SUPPLY

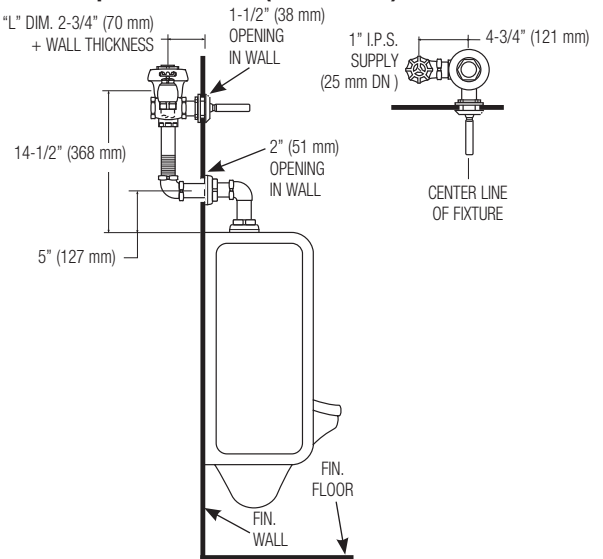

MODEL 195

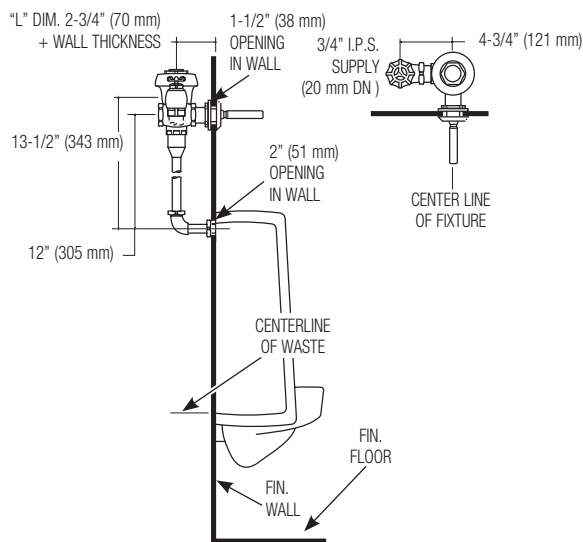

MODEL 197

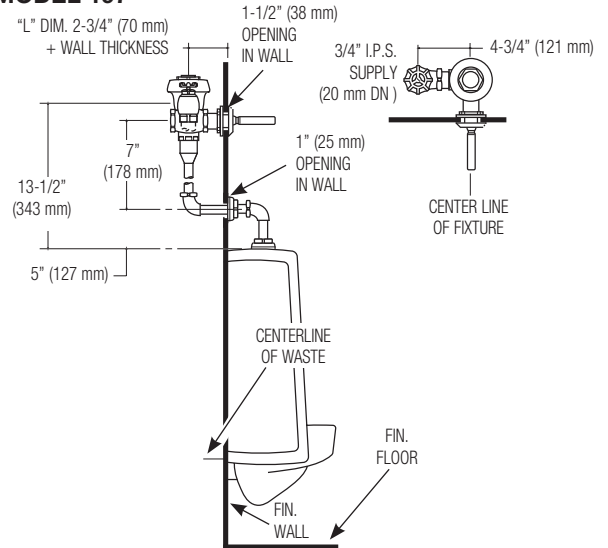

1 - INSTALL OPTIONAL SWEAT SOLDER ADAPTER (ONLY IF YOUR SUPPLY PIPE DOES NOT HAVE A MALE THREAD) AND INSTALL CONTROL STOP

A For Sweat Solder applications, slide Threaded Adapter onto water supply pipe until end of pipe rests against shoulder of Adapter. Sweat solder the Adapter to water supply pipe.

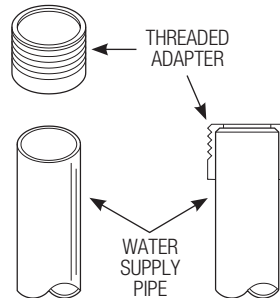

B Install the Sloan Bak-Chek® Control Stop to the water supply line with the outlet positioned as required.

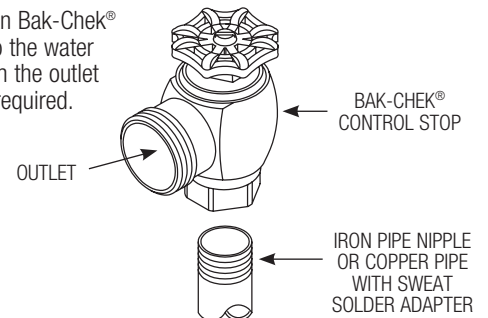

NOTE

CONCEALED VALVES ARE SUPPLIED WITH DOUBLE HANDLE OPENING TO ALLOW FOR INSTALLATION OF CONTROL STOP ON EITHER THE LEFT OR RIGHT SIDE OF THE VALVE (REFER TO ILLUSTRATION IN STEP 4).

2 - INSTALL VACUUM BREAKER AND FLUSH CONNECTION

!!! IMPORTANT !!!

DUE TO THE HIGH BACK PRESSURES THAT CAN BE CREATED BY STAINLESS WATER CLOSETS AND COMBINATION FIXTURES, THE FOLLOWING PROCEDURES MUST BE FOLLOWED WHEN INSTALLING THE FLUSH CONNECTION. FAILURE TO FOLLOW THESE PROCEDURES CAN RESULT IN SEPARATIONS. FOR SECURE CONNECTIONS IN HIGHER PRESSURE AND OTHER SEVERE CONDITION APPLICATIONS, THE FLUSH CONNECTIONS CAN BE SWEAT SOLDERED. REMOVE ALL PLASTIC AND RUBBER GASKETS BEFORE BEGINNING SOLDERING PROCESS.

When cutting Vacuum breaker and F-100/F-102 Flush Connection tubes to fit, always keep at least 1 1/4" (32 mm) of scoring to assure proper engagement with compression coupling (see Figure 2).

A

Install Flush Connection (Figure 1)

A 1 1/2" pipe connection (NOT supplied by Sloan) must be used to connect the fixture inlet from the wall to the flush connection. Secure flanged end of the F-100/F-102 Flush Connection to the 1 1/2" pipe using a 1 1/2" F-2-A Coupling with S-21 Gasket and Coupling nut. Tighten securely.

Items shown by dashed lines are not supplied by Sloan

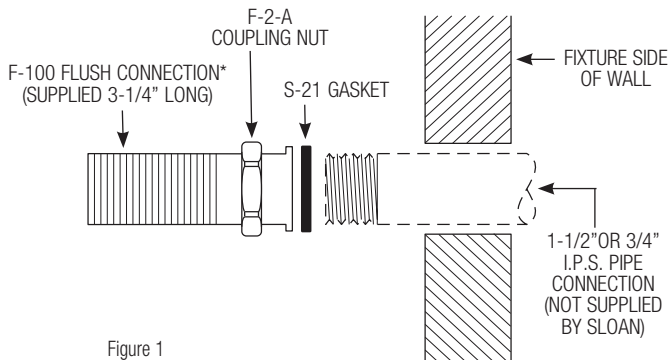

B

Install Slip Elbow (Figure 2)

Connect scored ends of vacuum breaker tube and F-100/F-102 flush connection to the elbow using coupling, slip gasket and rubber compression gasket. After applying Loctite® to scored ends, tighten securely.

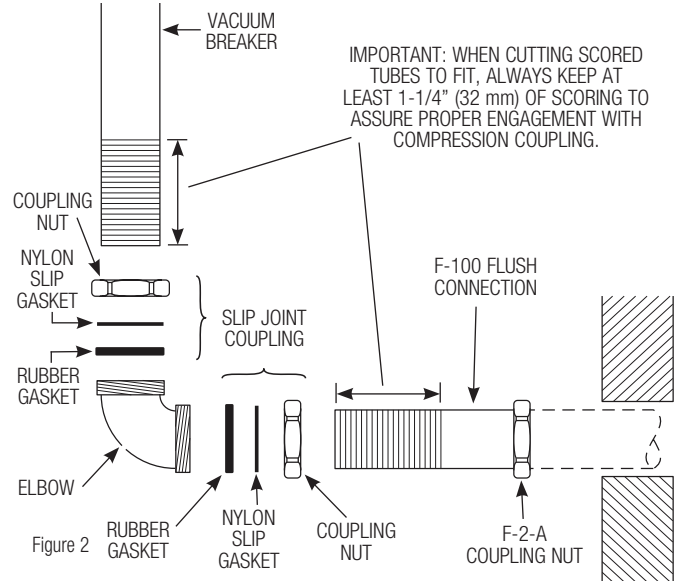

!!! IMPORTANT !!!

IMPORTANT: BEFORE INSERTING THE SCORED ENDS INTO THE ELBOW, APPLY SEVERAL DROPS OF LOCTITE (SUPPLIED BY SLOAN) TO THE SCORED ENDS OF THE TUBES (FIGURE 3). THIS SEALANT HELPS PREVENT SEPARATION UNDER HIGH-PRESSURE CONDITIONS. DO NOT USE ANY OTHER PIPE SEALANT OR LUBRICANT ON THIS CONNECTION.

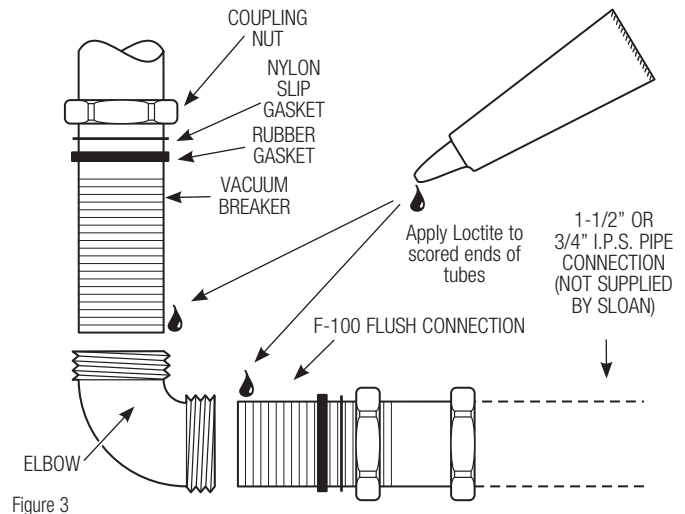

Loctite can also be used to secure Push Button Flange. See Sealant package for details.

3 - MOUNT ACTUATOR ASSEMBLY TO WALL

- A** Remove Actuator Shaft End, Coupling and Mounting Nut from Actuator Assembly.
- B** Insert Shaft of Actuator Assembly through the 1-1/2" (38 mm) wall opening from fixture side of wall.
- C** Install Mounting Nut, Coupling and Actuator Shaft End to Actuator Assembly. Hand tighten Mounting Nut to wall. Securely tighten Actuator Shaft End to Actuator assembly.

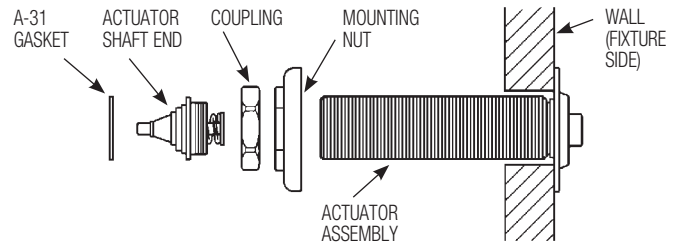

4 - INSTALL FLUSHOMETER

- A** Lubricate tailpiece O-ring with water. Insert Adjustable Tailpiece into Control Stop while mounting Flushometer to Actuator Assembly. Tighten Actuator and Tailpiece Couplings by hand.
- B** Align Flushometer directly above the Vacuum Breaker Flush Connection. Assemble Vacuum Breaker Flush Connection to Flushometer. Tighten Vacuum Breaker Coupling by hand.

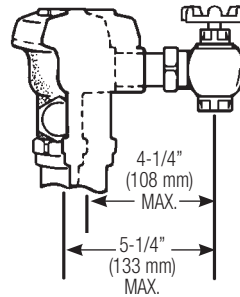

!!! IMPORTANT !!!

USE A SLOAN A-50 "SUPER-WRENCH™", SLOAN A-109 PLIER WRENCH OR SMOOTH JAWED SPUD WRENCH TO SECURE ALL COUPLINGS. THIS WILL ELIMINATE DAMAGE TO CHROME OR SPECIAL FINISH THAT NORMALLY OCCURS WHEN SLIP-JOINT PLIERS, PIPE WRENCHES OR OTHER "TOOTHED" TOOLS ARE USED.

- C** Use a wrench to tighten the following couplings in the order shown. Align Flushometer Body and securely tighten first the Tailpiece Coupling **(1)**, then the Actuator Coupling **(2)**, then the Vacuum Breaker Coupling **(3)**, then all Flush Connection Couplings **(4)** and finally the Spud Coupling **(5)**.
- D** Using a wrench, securely tighten Actuator Mounting Nut to wall.

NOTE

MAXIMUM ADJUSTMENT OF THE SLOAN ADJUSTABLE TAILPIECE IS 1/2" (13 MM) IN OR OUT FROM THE STANDARD 4-3/4" (121 MM) (CENTERLINE OF FLUSHOMETER TO CENTERLINE OF CONTROL STOP).

IF ROUGHING-IN MEASUREMENT EXCEEDS 5-1/4" (133 MM), CONSULT FACTORY FOR LONGER TAILPIECE.

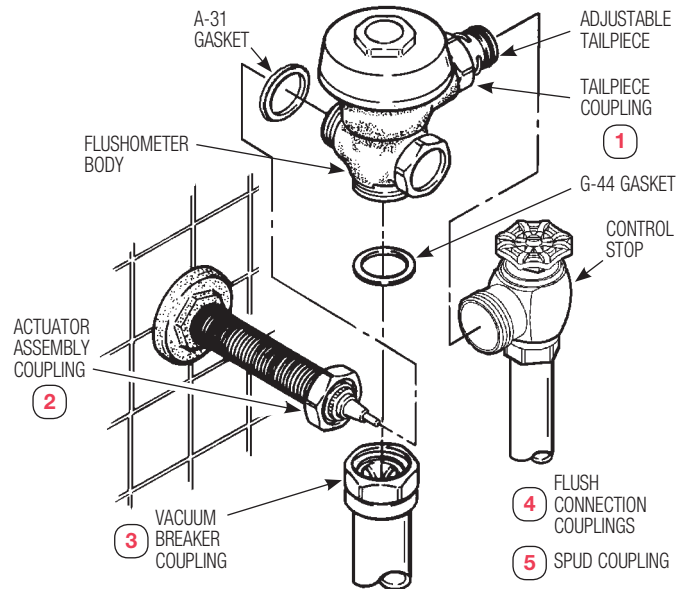

5 - FLUSH OUT SUPPLY LINE AND ADJUST CONTROL STOP

- A** Shut off Control Stop by turning handle **CLOCKWISE**. Then remove Flushometer Cover.
- B** Lift out the inside Parts Assembly as a complete unit. Reinstall Flushometer Cover and tighten with wrench. Open Control Stop. Turn on water supply to flush line of any debris or sediment.
- C** Shut off Control Stop and remove Flushometer Cover. Reinstall Inside Parts Assembly and Flushometer Cover. Tighten Cover with wrench. Open Control Stop and activate Flushometer Valve.
- D** Adjust Control Stop to meet flow rate required for proper cleansing of fixture. Open Control Stop **COUNTERCLOCKWISE ONE FULL** turn from closed position. Activate Flushometer. Adjust Control Stop after each flush until the rate of flow delivered properly cleanses the fixture.

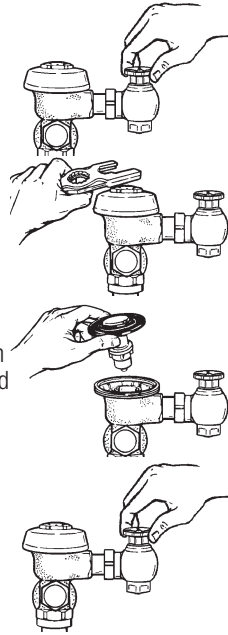

!!! IMPORTANT !!!

SLOAN FLUSHOMETERS ARE ENGINEERED FOR QUIET OPERATION. EXCESSIVE WATER FLOW CREATES NOISE, WHILE TOO LITTLE WATER FLOW MAY NOT SATISFY THE NEEDS OF THE FIXTURE. PROPER ADJUSTMENT IS MADE WHEN THE PLUMBING FIXTURE IS CLEANSSED AFTER EACH FLUSH WITHOUT SPLASHING WATER OUT FROM THE LIP AND A QUIET FLUSHING CYCLE IS ACHIEVED.

!!! IMPORTANT !!!

NEVER OPEN THE CONTROL STOP TO WHERE THE FLOW FROM THE VALVE EXCEEDS THE FLOW CAPABILITY OF THE FIXTURE. IN THE EVENT OF A VALVE FAILURE, THE FIXTURE MUST BE ABLE TO ACCOMMODATE A CONTINUOUS FLOW FROM THE VALVE.

TROUBLESHOOTING GUIDE

1. Flushometer does not function (no flush).

- Control Stop or Main Valve is Closed. Open Control Stop or Main Valve.
- Handle or Push Button Assembly is worn. Install Sloan Handle Repair Kit (C-70-A) or replace handle or push button.
- Relief Valve is worn. Replace Royal Performance Kit (Royal) or Inside Parts Kit (Regal).

2. Volume of water is not sufficient to siphon fixture.

- Control Stop is not open wide enough. Adjust Control Stop for desired delivery of water volume.
- Urinal flushometer parts installed in a Closet flushometer. Replace inside Urinal Flushometer parts with proper Closet Flushometer parts.
- Incorrect Dual Filtered Diaphragm Assembly (Royal Flushometers) or Inside Parts Kit (Regal Flushometers) is installed in flushometer; for instance, Urinal assembly inside a Closet flushometer, or Low Consumption assembly inside a higher consumption fixture. Determine the flush volume required by the fixture and replace Royal Performance Kit or Inside Parts Kit. Use valve label and markings on fixture for reference.
- Water supply volume or pressure is inadequate. If no gauges are available to properly measure supply pressure or volume of water at the Flushometer, then remove the Relief Valve from the Dual Filtered Diaphragm Assembly (Royal) or Inside Parts Kit (Regal), reassemble the flushometer and completely open the Control Stop. If the fixture siphons, more water volume is required.

IMPORTANT — LAWS AND REGULATIONS PROHIBIT THE USE OF HIGHER FLUSHING VOLUMES THAN LISTED ON FIXTURE OR FLUSHOMETER.

If the fixture does not siphon or if a Low Consumption flush is required, steps must be taken to increase the water supply pressure and/or volume. Contact the fixture manufacturer for minimum water supply requirements of the fixture.

3. Flushometer closes off immediately.

- Ruptured or damaged diaphragm. Replace Royal Performance Kit (Royal) or Inside Parts Kit (Regal).
- For Regal Flushometers** — An enlarged bypass orifice from corrosion or damage. Replace Inside Parts Kit.

4. Length of flush is too short (Short Flush).

- For Regal Flushometers** — The Diaphragm Assembly and Guide Assembly are not hand tight. Screw the two assemblies hand tight.
- For Regal Flushometers** — An enlarged bypass orifice from corrosion or damage. Replace Inside Parts Kit.
- Dual Filtered Diaphragm Assembly (Royal) or Inside Parts Kit (Regal) is damaged. Replace Royal Performance Kit or Inside Parts Kit.
- Incorrect Dual Filtered Diaphragm Assembly (Royal) or Inside Parts Kit (Regal) is installed in Flushometer; for instance, Urinal assembly inside a Closet Flushometer, or Low Consumption assembly inside a higher consumption fixture. Determine the flush volume required by the fixture and replace Royal Performance Kit or Inside Parts Kit. Use valve label and markings on fixture for reference.
- Handle or Push Button Assembly is worn. Install Sloan Handle Repair Kit (C-70-A) or replace handle or push button.

5. Length of flush is too long (Long Flush) or continuous.

- For Royal Flushometers** — Metering bypass hole in Diaphragm is clogged. Remove the Dual Filtered Diaphragm Assembly. Remove the Primary and Secondary Filter Rings from the Diaphragm and wash under running water. Replace Royal Performance Kit if cleaning does not correct the problem.
- For Regal Flushometers** — Relief Valve (A-19-A) is not seating properly or bypass orifice is clogged. Disassemble the working parts and wash thoroughly.

NOTE: SIZE OF THE ORIFICE IN THE BYPASS IS OF UTMOST IMPORTANCE FOR THE PROPER METERING OF WATER INTO THE UPPER CHAMBER OF THE FLUSHOMETER. DO NOT ENLARGE OR DAMAGE THIS ORIFICE. REPLACE INSIDE PARTS KIT IF CLEANING DOES NOT CORRECT PROBLEM.

- Supply line water pressure has dropped and is not sufficient to close the valve. Close Control Stop until pressure is restored.
- Dual Filtered Diaphragm Assembly (Royal) or Inside Parts Kit (Regal) is damaged. Replace Royal Performance Kit or Inside Parts Kit.
- Incorrect Dual Filtered Diaphragm Assembly (Royal) or Inside Parts Kit (Regal) is installed in Flushometer; for instance, Urinal assembly inside a Closet flushometer, or Low Consumption assembly inside a higher consumption fixture. Determine the flush volume required by the fixture and replace Royal Performance Kit or Inside Parts Kit. Use valve label and markings on fixture for reference.
- White Closet Relief Valve has been used in a Urinal flushometer. Replace Closet Relief Valve (A-19-AC) with Black Urinal Relief Valve (A-19-AU).
- Inside Cover is cracked or damaged. Replace the Inside Cover (A-71).
- Conditions in the piping system may contribute to the noise. A degree of high pressure in the piping may be relieved by adjustments to Control Stop. Other noises created by loose pipes, lack of air chambers, inadequate pipe sizes, etc., are problems that must be discussed with the building engineer.

6. Chattering noise is heard during flush.

- Inside Cover is damaged. Replace Inside Cover (A-71).
- For Regal Flushometers** — A-156-A Segment Diaphragm has been installed upside-down. Reposition the Segment Diaphragm properly (see markings on the Diaphragm).

7. Leaking at Handle or Push Button Assembly.

- The B-39 Seal is worn or deteriorated. Install new B-39 Seal.
NOTE: The B-39 Seal will easily slide onto the B-40 Bushing if it is wet.
- Handle gasket has been omitted. Install A-31 Handle Gasket or Sloan Handle Repair Kit (C-70-A).
- Valve Handle Bushing is worn. Install Sloan Handle Repair Kit (C-70-A).

**When further assistance is required, please contact your local Sloan Representative or Sloan Technical Support at:
1-888-SLOAN-14 (1-888-756-2614)
or visit us online at: www.sloan.com**