

INSTRUCTION MANUAL

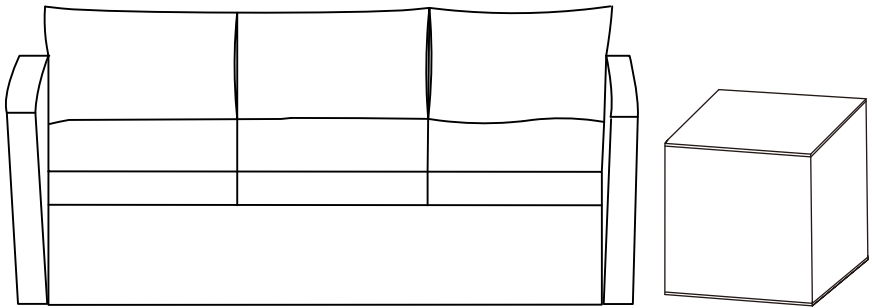

Sofa And Side Table
Rattan Seating Group with Cushion
SKU: OP114

V1.0

! NOTICE

Do not overtighten screws. (Insert all screws before tighten screws.)

- Please do not exceed the weight limitations of this item.
- Do not stand on or use any part of this item as a step ladder.
- Firmly secure all bolts, screws and nuts before use.
- Reconfirm that all bolts, screws, and nuts are secure every 90 days.
- Do not use or store this item in the proximity of open flame or flammable/combustible chemicals.
- Be aware that some parts are heavy and have sharp edges.

TOOLS REQUIRED



ALLEN WRENCH
(PROVIDED)



CHAIR
330 LBS
CAPACITY



LONGCHAIR
660 LBS
CAPACITY



TABLE
110 LBS
CAPACITY



2 PERSONS
ASSEMBLY



UP TO 60 MIN.
ASSEMBLY

HARDWARE

1

M6 x 35MM
BOLT



32 PCS

2

M6 x 25MM
BOLT



2 PCS

3

SPACER



2 PCS

4

M6 WASHER



32 PCS

5

ALLEN
WRENCH

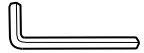

1 PC

6

M6
THREADED PIN



2 PCS

PARTS

A

CHAIR LEFT SIDE

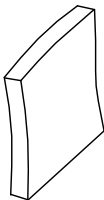

1 PC

B

CHAIR RIGHT SIDE

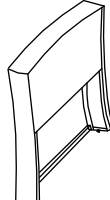

1 PC

C

SOFA BACKREST

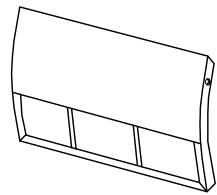

1 PC

PARTS

D

SOFA SEAT

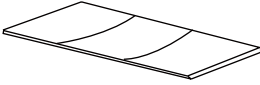

1 PC

E

FRONT RAIL

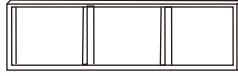

1 PC

F

TABLE LEFT RAIL

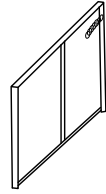

1 PC

G

TABLE RIGHT RAIL

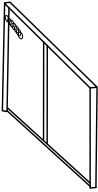

1 PC

H

TABLE TOP

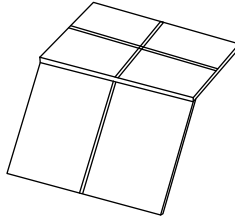

1 PC

I

TABLE BASE

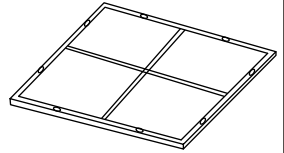

1 PC

J

TABLE FRONT RAIL

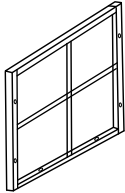

1 PC

K

LINING

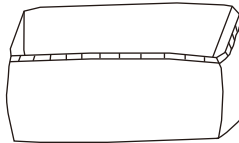

1 PC

CUSHION

Z1

BACK CUSHION

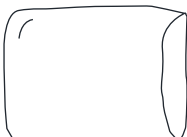

3 PCS

Z2

SEAT CUSHION

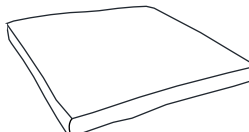

3 PCS

PRODUCT ASSEMBLY - THREE-PERSON SOFA

1

Attach part E Front Rail to part D Sofa Seat with 3 PCS of part 1 Bolt and part 4 Washer .

Do not tighten screws too much at this stage.

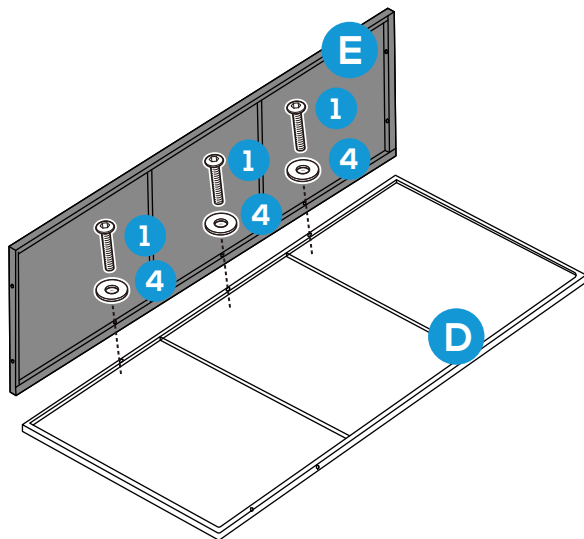

2

Attach the combined part (D+E) to part C Sofa Backrest with 3 PCS of part 1 Bolt and part 4 Washer.

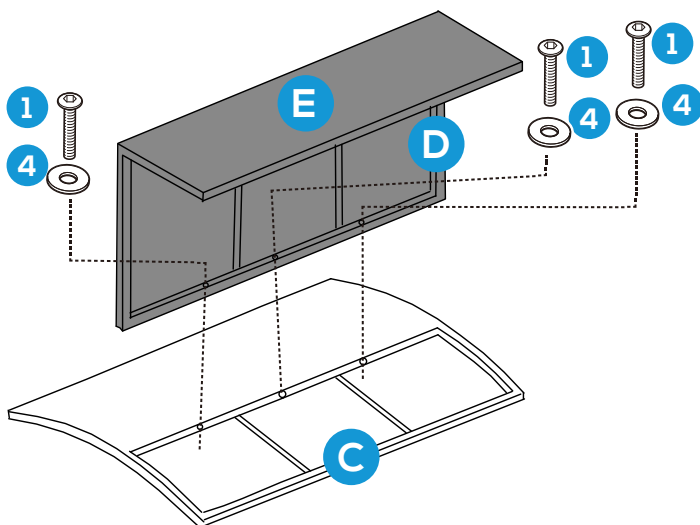

PRODUCT ASSEMBLY - THREE-PERSON SOFA

3

Attach the combined part (C+D+E) to part B Chair Right Side with 5 PCS of part 1 Bolt and part 4 Washer.

Screw part 6 Threaded pin into the hidden nut firstly before this step.

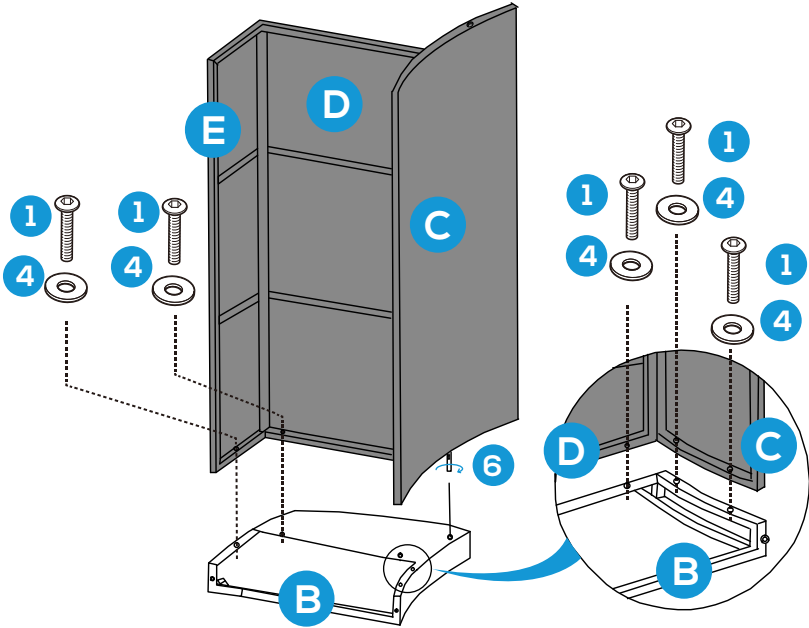

4

Attach the combined part (C+D+E) to part A Chair Left Side with 5 PCS of part 1 Bolt and part 4 Washer.

Screw part 6 Threaded pin into the hidden nut before assembly..

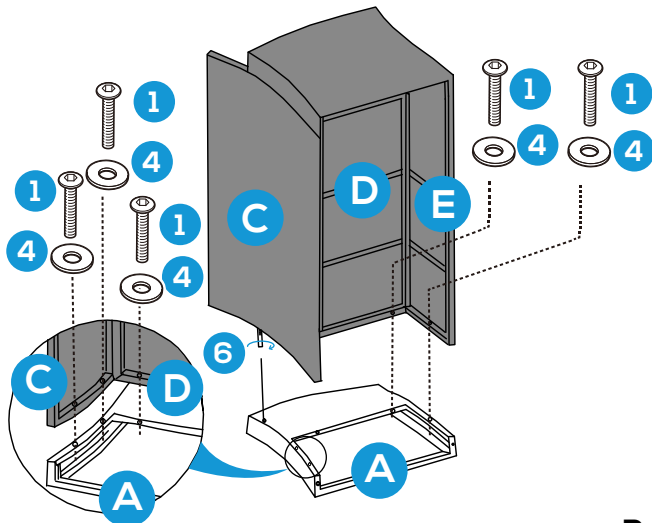

PRODUCT ASSEMBLY - THREE -PERSON SOFA

5

Tighten all bolts again to ensure this sofa is stable enough to use.

Place 3 PCS of part Z2 Seat Cushion and part Z1 Back Cushion into the sofa to finish the assembly.

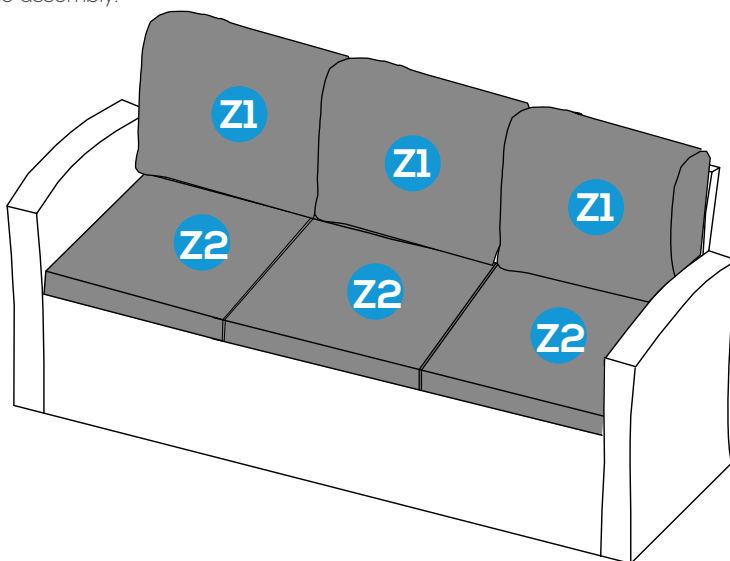

PRODUCT ASSEMBLY - COFFEE TABLE

6

Attach part F and G Table Rails to part H Table Top with 4 PCS of part 2 Bolt and part 4 Washer.

Do not tighten screws too much at this stage.

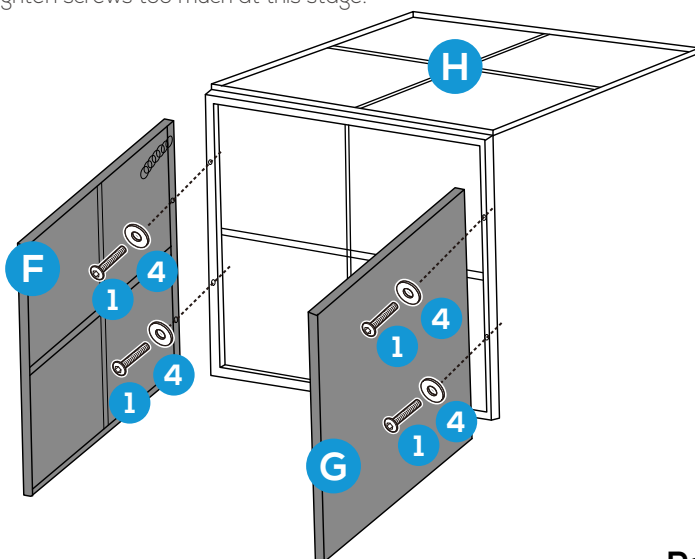

PRODUCT ASSEMBLY - COFFEE TABLE

7

Attach part I Table Base to part F and G Table Rails as well as part H Table Top with 6 PCS of part 1 Bolt and part 4 Washer.

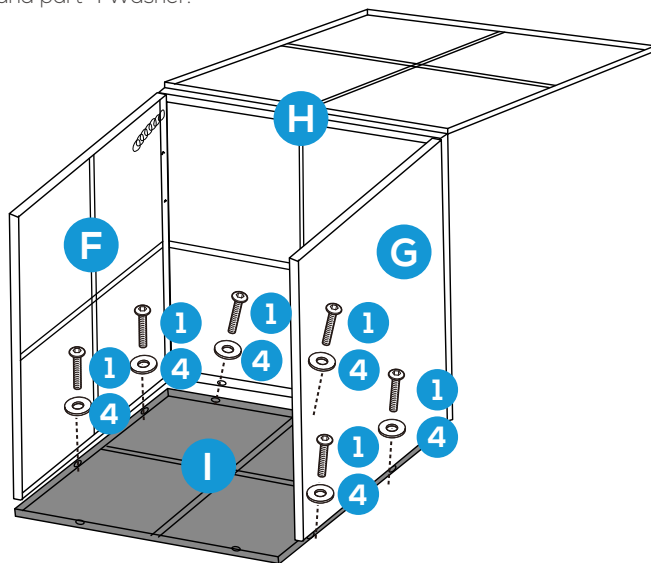

8

Attach part J Table Front Rail to part F and G Table Rails and part I Table base with 6 PCS of part 1 Bolt and part 4 Washer.

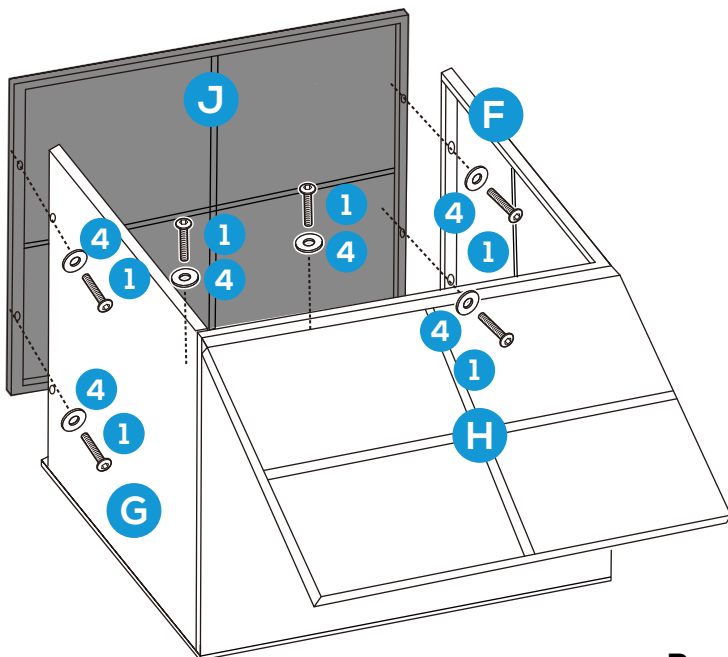

PRODUCT ASSEMBLY - COFFEE TABLE

9

Attach the chains to Table Top with 2 PCS of part 2 Bolt and part 3 Spacer and attach part K Lining inside with velcro.

Close the Table top and convert it to a coffee table while open it as a storage box.

