















PART Pièce Pieza		Qty. Qte. Ctd.
A		5
B		1
C		1
D		1
E		1
F		1
G		1
H		1
I		4
J		2
K		4
L		4
M		6
N		1

**1.**



**2.**

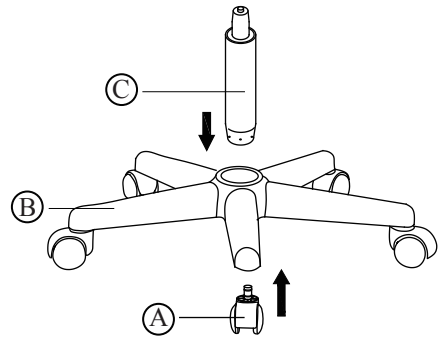
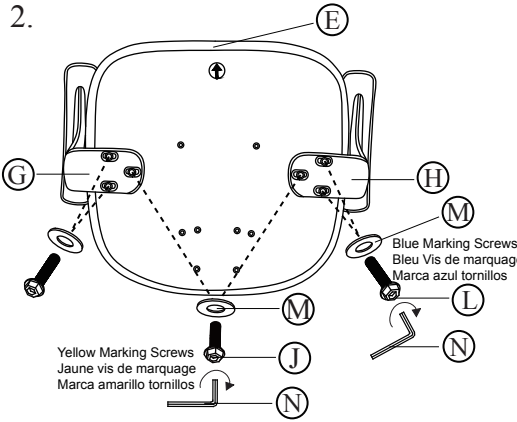

Yellow Marking Screws  
Jaune vis de marquage  
Marca amarillo tornillos

Blue Marking Screws  
Bleu Vis de marquage  
Marca azul tornillos

**3.**

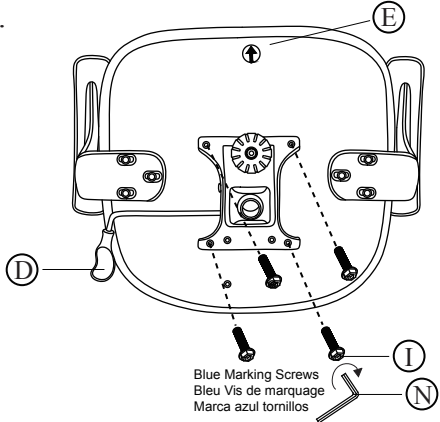

Blue Marking Screws  
Bleu Vis de marquage  
Marca azul tornillos

**4.**

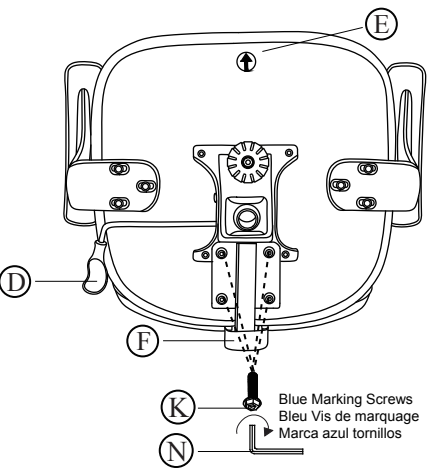

Blue Marking Screws  
Bleu Vis de marquage  
Marca azul tornillos

**5.**

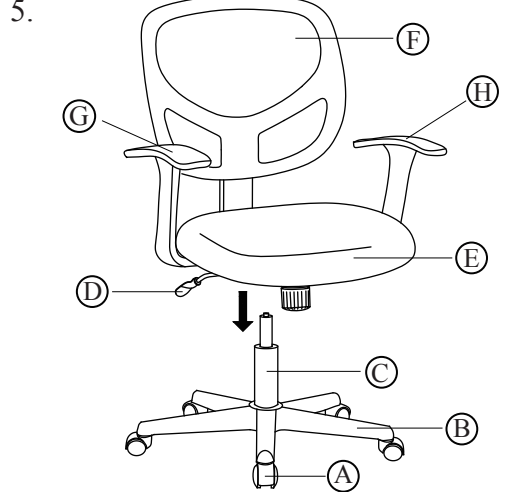

**6.**



### ATTENTION / ATTENTION / ATENCION

Make sure all bolts and screws are fully tightened before using chair. Lubricate all moving parts and tighten all bolts/screws every 6 month or whenever needed.

S'assurer que tous les boulons et vis sont serrés à fond avant d'utiliser la chaise. Lubrifier toutes les pièces mobiles et serrer tous les boulons/vis tous les 6 mois ou selon le besoin.

Asegúrese que todos los pernos y tornillos estén completamente apretados antes de usar la silla. Lubrique todas las piezas móviles y apriete todos los pernos/tornillos cada 6 meses o como sea necesario.

### ⚠WARNING / AVERTISSEMENT / ADVERTENCIA

To ensure proper assembly, follow all steps and use all parts. Failure to follow this warning can result in serious injury to yourself or others.

Effectuer toutes les opérations et utiliser toutes les pièces pour être sûr que l'assemblage est correct. L'inobservation de cet avertissement peut entraîner des blessures graves pour soi ou pour les autres.

Para asegurar un armado correcto, siga todos los pasos indicados y utilice todas las piezas. Si no se observa esta advertencia, se pueden causar lesiones graves a su persona o a los demás.

## ESS-3001

### SEAT HEIGHT

Lift this lever to adjust the seat height. Release the lever to lock the seat height.

Pull lever outwards to allow the chair to recline. Push lever inwards to lock in the upright position.

### ALTURA DE ASIENTO

Levante la palanca para ajustar la altura del asiento. Suelte la palanca para trabar la altura del asiento.

Tirez le levier vers l'extérieur pour permettre l'inclinaison. Poussez le levier pour verrouiller en position verticale.

### HAUTEUR DE SELLE

Soulevez ce levier pour régler la hauteur du siège. Relâchez le levier pour verrouiller la hauteur du siège.

Tirer de la palanca hacia el exterior para permitir que la silla reclinable. Empuje hacia dentro la palanca para bloquear en posición vertical.

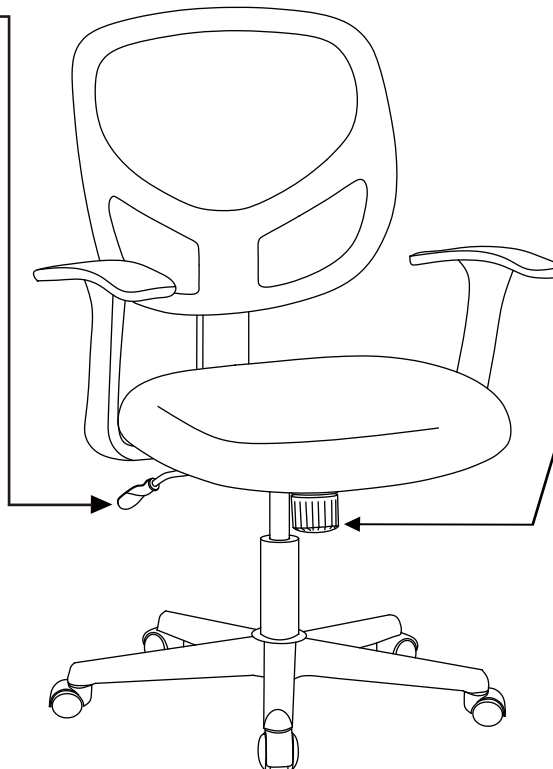

### TILT TENSION

Turn knob clockwise to increase tilt tension. Turn counterclockwise to loosen.

### TENSIÓN DE INCLINACIÓN

Gire la perilla en sentido horario para aumentar la tensión de inclinación. Gire a la izquierda para aflojar.

### TENSION D'INCLINAISON

Tourner le bouton vers la droite pour augmenter la tension du basculement. Tourner dans le sens antihoraire pour desserrer.



## LIMITED 3-YEAR WARRANTY

OFM LLC promises to repair or replace any Essentials by OFM product or component that is found to be defective in material or workmanship within three (3) years from the date of original purchase so long as you, the original purchaser, still owns it. This is your sole and exclusive remedy. This warranty is subject to the provisions below. This warranty applies solely to Essentials by OFM products with model numbers beginning with the characters ESS.

### LIMITATIONS

- Upholstery on chairs is warranted for two years from date of purchase.
- Damage caused by the carrier in-transit is handled under separate terms.

### EXCLUSIONS

This warranty does not apply and no other warranty applies to:

- Normal wear and tear, which are to be expected over the course of ownership.
- Modifications or attachments to the product that are not approved by OFM.
- Products that were not installed, used, or maintained in accordance with product instructions and warnings.
- Products used for rental purposes.

### SEATING USAGE

Normal commercial use for seating is identified as the equivalent of a single shift, forty- (40) hour workweek. To the extent that a seating product is used in a manner exceeding this, the applicable warranty period will be reduced in a pro-rata manner.

### A WORD ABOUT COLOR VARIATIONS, FABRICS AND FINISHES

OFM does not warrant the color-fastness or matching of colors, grains, or textures of covering materials.

### CUSTOMER'S OWN MATERIAL (COM)

Not available on Essentials by OFM product.

TO THE EXTENT ALLOWED BY LAW, OFM LLC MAKES NO OTHER WARRANTY, EITHER EXPRESS OR IMPLIED, INCLUDING ANY WARRANTY OF MERCHANTABILITY OR FITNESS FOR A PARTICULAR PURPOSE. THE HON COMPANY WILL NOT BE LIABLE FOR ANY CONSEQUENTIAL OR INCIDENTAL DAMAGES.

### NOTICE TO PURCHASERS FOR HOME OR PERSONAL USE

Federal law does not permit the exclusion of certain implied warranties for consumer products. Therefore, if you are purchasing this product for home or personal use, the exclusion of implied warranties noted in the above paragraph does not apply to you. Some states do not allow the exclusion or limitation of incidental or consequential damages, so the above limitation or exclusion may not apply to you. This warranty gives you specific legal rights, and you may also have other rights which vary from state to state.

This warranty applies only to products sold within the United States of America and the Commonwealth of Canada.

### TO OBTAIN SERVICE UNDER THIS WARRANTY

Your Essentials by OFM Merchant is our mutual partner in supporting your warranty requests. By following the procedures outlined below, you can be assured of the best level of service. Please note: Consent of OFM must be obtained before any warranty work is performed.

To obtain consent, please take the following steps:

1. Contact the Merchant from whom the product was purchased within 30 days of discovery of the defect. Be prepared to affirm that you are the original purchaser of the product and to provide the serial number(s) from the product in question.
2. Your Merchant will gather all pertinent information regarding the claim, inspect the product, and contact an OFM customer service representative. (Please allow a reasonable amount of time for inspection and review.)
3. If OFM affirms that the product in question is eligible under the conditions of the warranty as stated above, the customer service representative or another representative of OFM will determine whether to provide replacement parts, authorize repairs, or replace the product.