

*Adventure Starts Here.*

**ADIRONDACK SWIVEL BAR CHAIR**

**SEAHAWK  
DESIGNS**

EST. 2005

## ! NOTICE

- Do not overtighten hardware.
- Do not exceed the weight capacity of this item.
- Only use this item for what it is intended for, improper use will void any warranty.
- Firmly secure all bolts, screws and nuts before use.
- Reconfirm that all bolts, screws, and nuts are firmly secured every 90 days.
- Keep this furniture clear of all uncontrolled open flames or flammable/combustible materials. Exposure to fire, high heat, or embers will permanently damage the material.
- To avoid stripping and cracking of the material, DO NOT use power tools for assembly.
- Always prioritize caution and safety throughout the assembly process.

## TOOLS REQUIRED

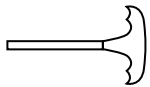

**ALLEN WRENCH**  
(PROVIDED)

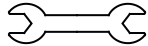

**WRENCH**  
(PROVIDED)



**330 LBS**  
**WEIGHT**  
**CAPACITY**



**SUGGESTED**  
**2 PERSON**  
**ASSEMBLY**



**ESTIMATED**  
**ASSEMBLY**  
**TIME: 20 MIN**

1

**SCREW**  
M6 x 40mm



17 PCS

2

**SCREW**  
M6 x 70mm



10 PCS

3

**SCREW**  
M6 x 80mm



2 PCS

4

**BOLT**  
M6 x 45mm

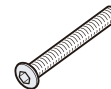

4 PCS

5

**BOLT**  
M6 x 55mm

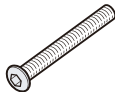

4 PCS

6

**M6-NUT**



8 PCS

7

**M6-WASHER**

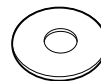

8 PCS

8

**SWIVEL DISC**

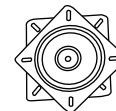

1 PCS

9

**SCREW HOLE PLUG**



24 PCS

**A**

**CHAIR SEAT**

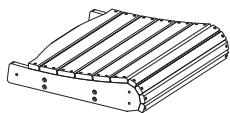

1 PC

**B**

**CHAIR BACKREST**



1 PC

**C**

**LEFT FRONT LEG**

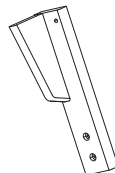

1 PC

**D**

**RIGHT FRONT LEG**

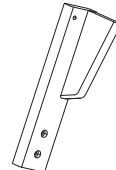

1 PC

**E**

**LEFT REAR LEG**



1 PC

**F**

**RIGHT REAR LEG**



1 PC

**G**

**LEFT ARM**

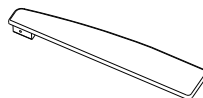

1 PC

**H**

**RIGHT ARM**

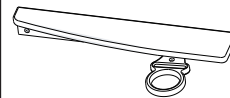

1 PC

**I**

**CUP HOLDER**

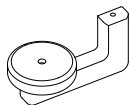

1 PC

**J**

**SWIVEL SUPPORT I**

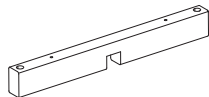

1 PC

**K**

**SWIVEL SUPPORT II**

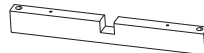

1 PC

**L**

**BOTTOM LEG**

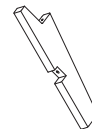

4 PCS

**M**

**BOTTOM FRAME**

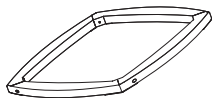

1 PC

**N**

**SEAT RAIL**

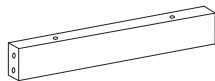

2 PC

# PRODUCT ASSEMBLY - OVERALL VIEW

REF#: OP7042

Please refer back to this image during the assembly process for part placement.

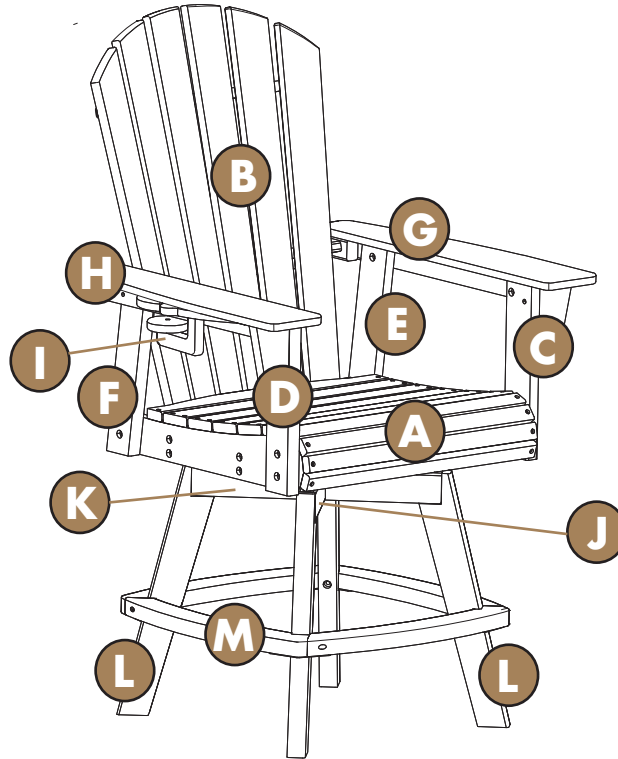

1

## Step 1: Assemble the Swivel Base

- Place **Part M (Bottom Frame)** on a flat, stable surface with connecting hardware facing upward (see image below).
- Attach **4 - Part L (Bottom Leg)** to **Part M (Bottom Frame)** using **4 - M6 Screw (#2)** (see image below).

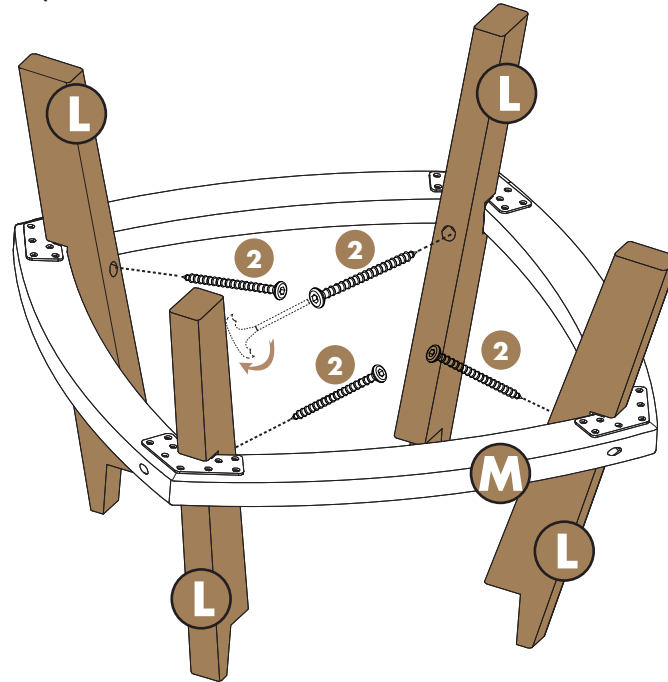

## 2

### Step 2: Attach the Swivel Support

- Place **Part J (Swivel Support I)** and **Part K (Swivel Support II)** onto **4 - Part L (Bottom Leg)** and attach them using **4 - M6 Screw (#2)**.
- Insert **4 - Screw Hole Plug (#9)** into the screw holes. Gently tap each plug into place using a rubber mallet to prevent damage. Ensure each plug is fully seated and flush with the surface (see image below).

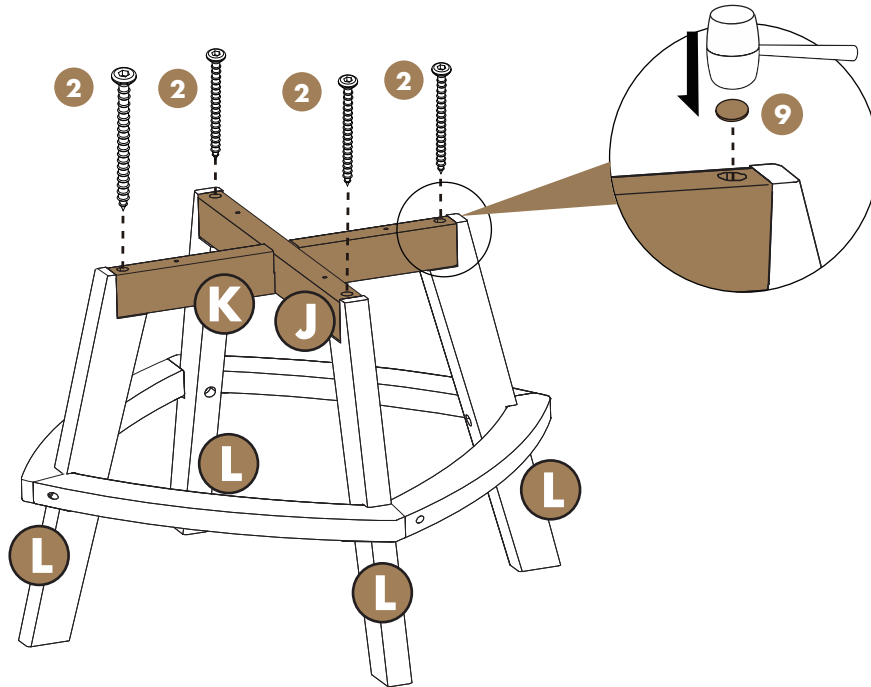

## 3

### Step 3: Attach the Swivel Disc to the Assembled Swivel Base

- Attach the **Swivel Disc (#8)** to **Part J (Swivel Support I)** and **Part K (Swivel Support II)** using **4 - M6 Screw (#1)** (see image below).

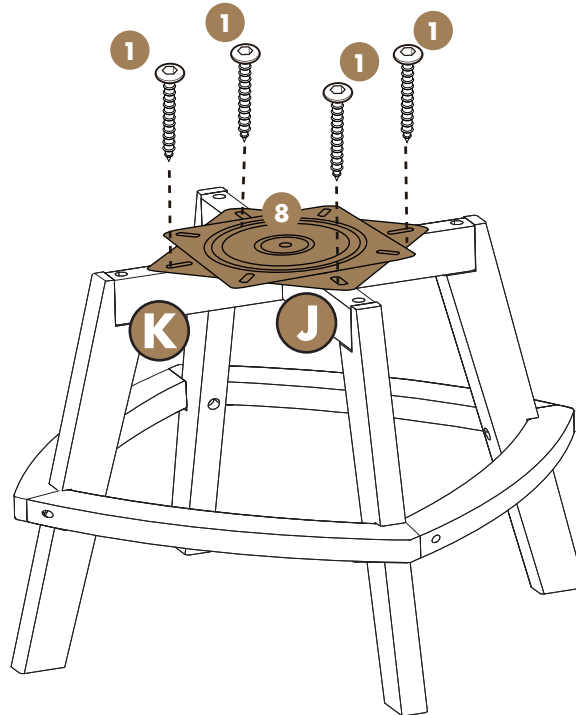

## 4

### Step 4: Assemble the Seat Rail

- Place **Part A (Chair Seat)** upside down on a flat, stable surface.
- Attach **2 - Part N (Seat Rail)** to **Part A (Chair Seat)** using **8 - M6 Screw (#1)** (see image below).
- Make sure the swivel disc assembly holes face outward.

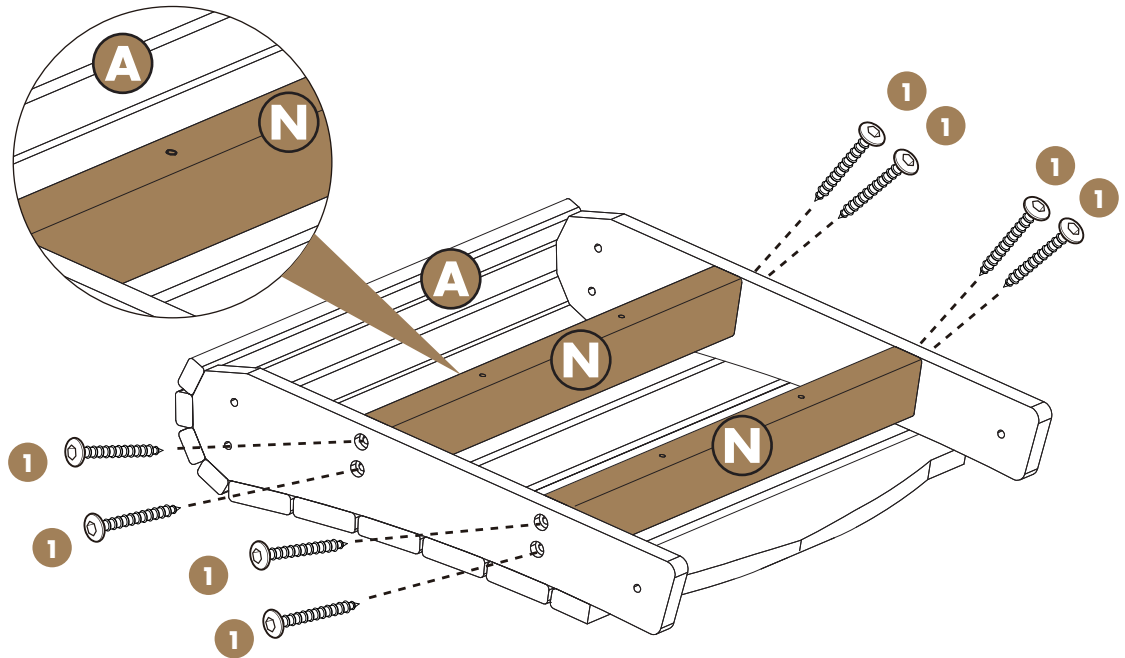

## 5

### Step 5: Assemble the Chair Seat and the Front Legs

- Attach **Part C (Left Front Leg)** to **Part A (Chair Seat)** using **2 - M6 Bolt (#4)**, **2 - M6 Washer (#7)**, and **2 - M6 Nut (#6)** (see image below).
- Attach **Part D (Right Front Leg)** to **Part A (Chair Seat)** using **2 - M6 Bolt (#4)**, **2 - M6 Washer (#7)**, and **2 - M6 Nut (#6)** (see image below).

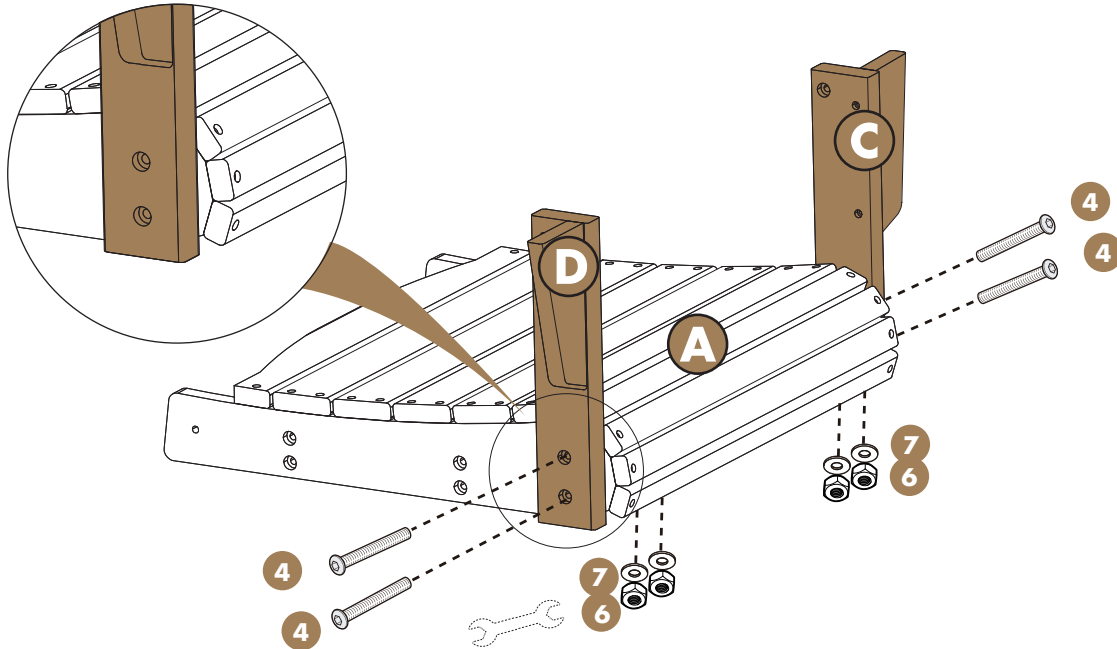

## 6

Step 6: Attach the Swivel Base to the Chair

- Attach the **Swivel Disc (#8)** on the combined **Swivel Base (4 - Part L, Part M, Part J and Part K)** to the Rails on **Part A (Chair Seat)** using **4 - M6 Screw (#1)** (see image below).

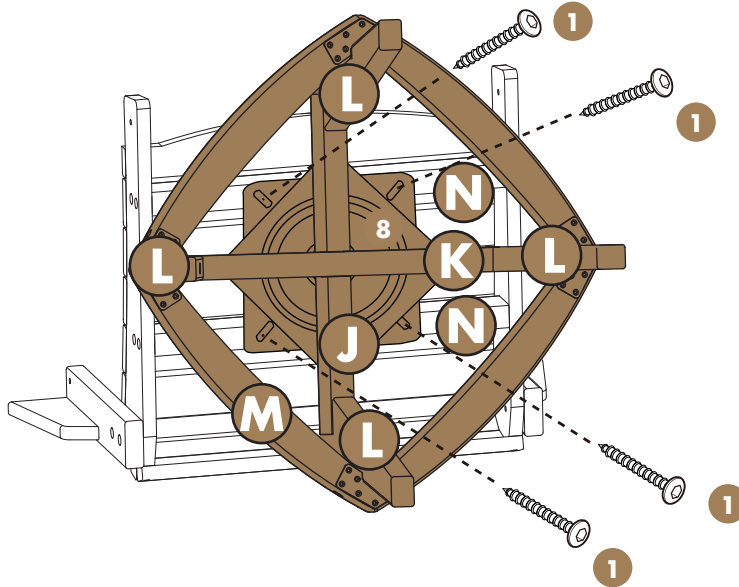

## 7

Step 7: Attach the Cup Holder to the Arm, and Arm to Chair

- Attach **Part I (Cup Holder)** to the bracket on **Part H (Right Arm)** using **1 - M6 Screw (#1)** (see image below).
- Next, secure the combined **Part H (Right Arm with Cup Holder)** unit to **Part D (Right Front Leg)** using **1 - set of the M6 Bolt (#5), M6 Washer (#7), and M6 Nut (#6)** (see image below).

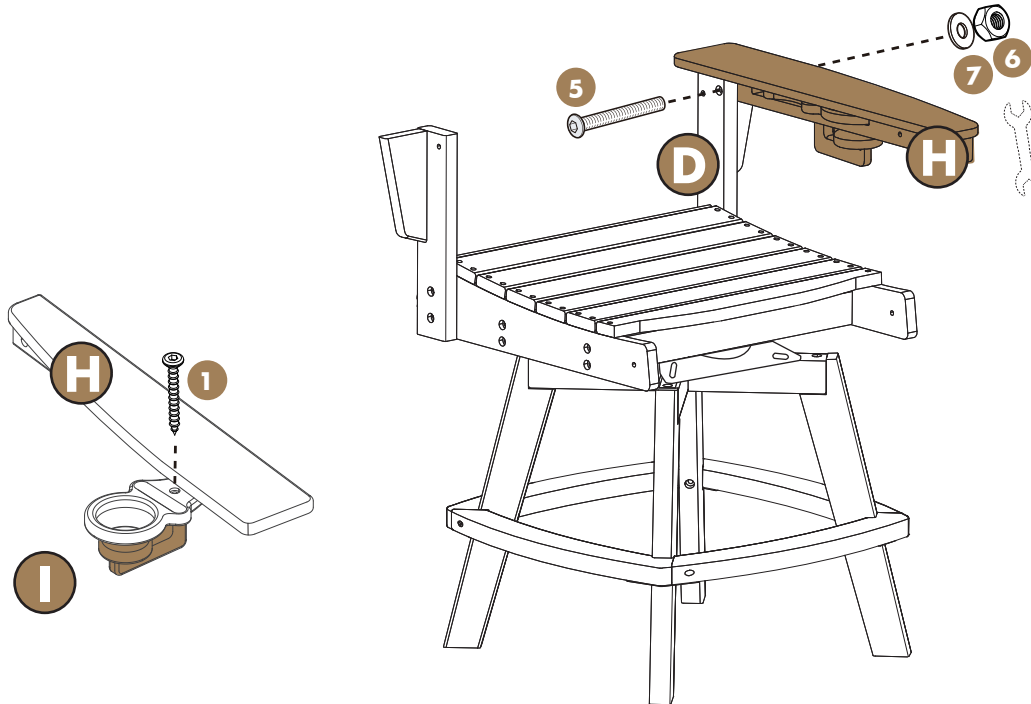

## 8

### Step 8: Attach the Second Arm to the Chair

- Mirror the previous step (Step 7) on the opposite side. Secure **Part G (Left Arm)** to **Part C (Left Front Leg)**. This requires 1 - set of the **M6 Bolt (#5)**, **M6 Washer (#7)**, and **M6 Nut (#6)** (see image below).

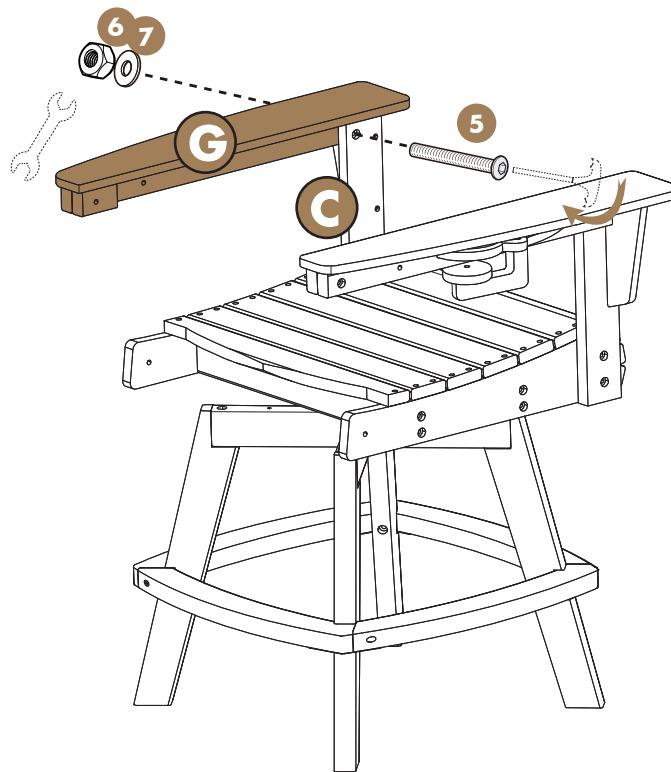

## 9

### Step 9: Attach the Rear Legs to the Chair

- Attach **Part E (Left Rear Leg)** to **Part G (Left Arm)** using 1- set of the **M6 Bolt (#5)**, **M6 Washer (#7)**, and **M6 Nut (#6)** (see image below).
- Insert 1 - **M6 Screw (#2)** to the holes into **Part E (Left Rear Leg)** and **Part A (Chair Seat)** to support the arm at this stage (see image below).
- Do the same to attach **Part F (Right Rear Leg)** to **Part H (Right Arm with Cup Holder)** and **Part A (Chair Seat)**.

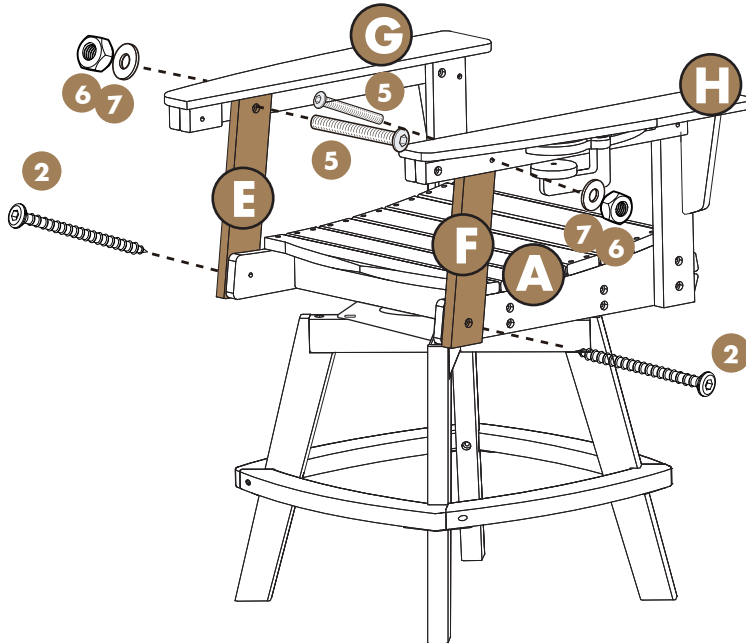

## 10

### Step 10: Attach the Backrest to the Assembled Frame

- Attach **Part B (Chair Backrest)** to the assembled frame. Use **2 - M6 Screw (#3)** and the pre-inserted **2 - M6 Screw (#2)** to secure it (see image below).

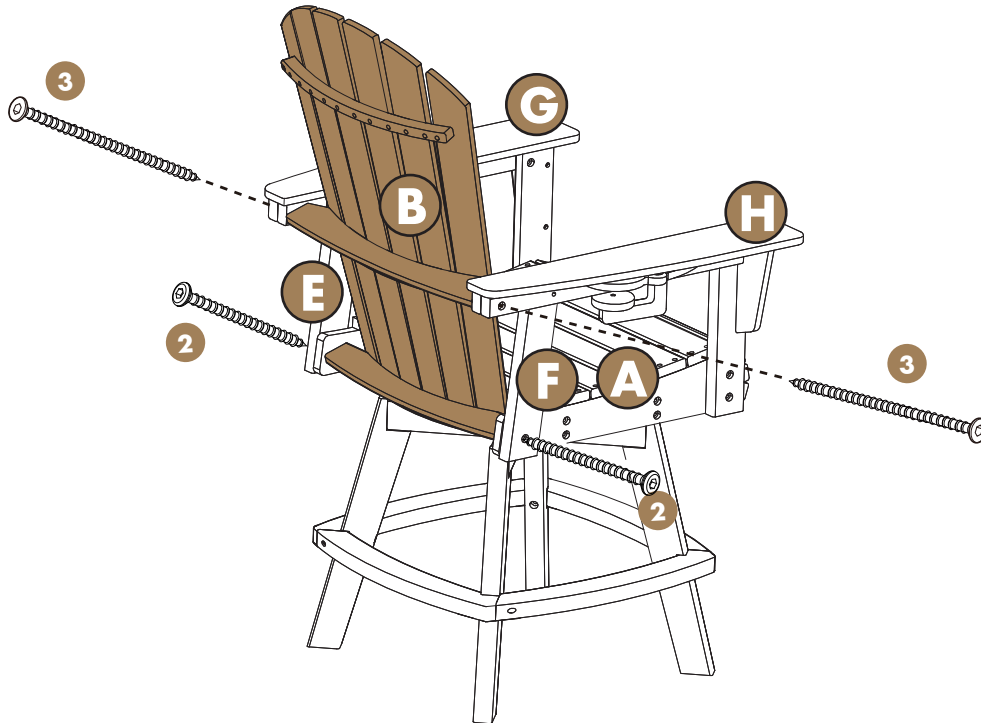

## 11

### Step 11: Final Tightening and Stability Check

- Tighten all previously installed screws, bolts, and nuts. Check every connection to ensure the chair is steady and stable.

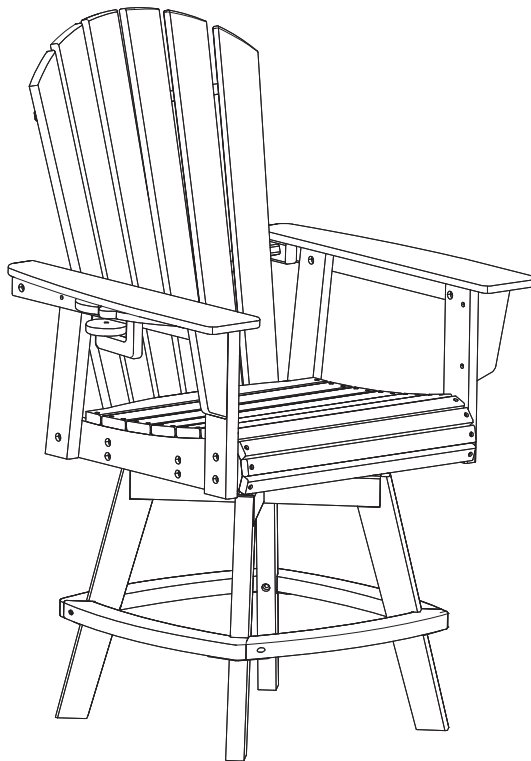

## 12

### Step 8: Apply the Screw Hole Plugs

- Cover all exposed screw holes using **20 - Screw Hole Plug (#9)**. Insert all plugs into the exposed screw holes. Gently tap each plug into place using a rubber mallet to prevent damage. Ensure each plug is fully seated and flush with the surface (see image below).

**ATTENTION:** Do not use a metal hammer as it will damage the poly lumber.

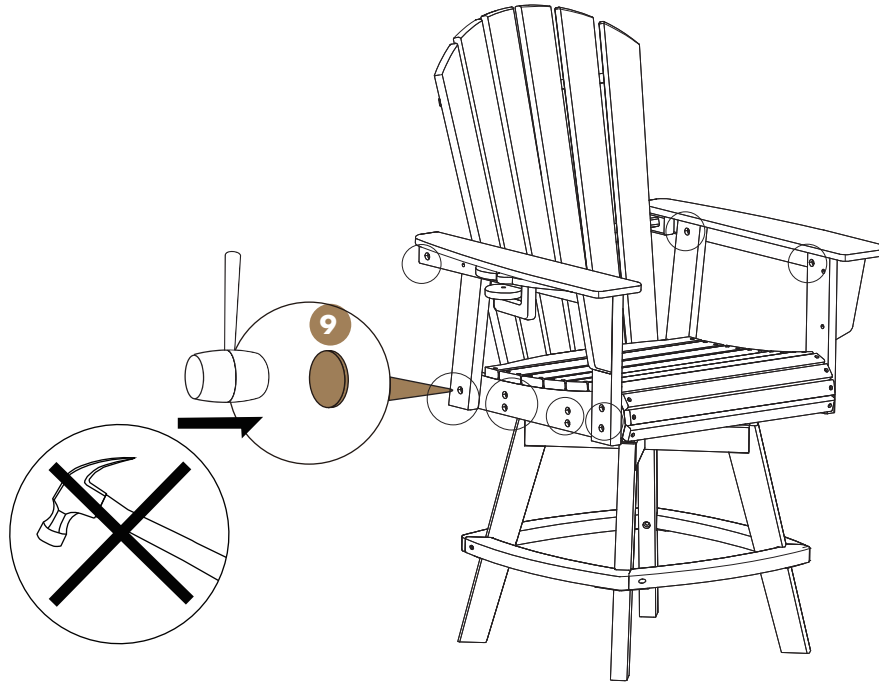

## CLEANING TIPS

- **REGULAR CLEAN:** Mix **warm water** and **mild soap**. Use **a soft bristle brush** to gently scrub the surface and remove any dirt or stains.
- **QUICK CLEAN:** Simply wipe the furniture down using a damp cloth.

Tip: Cleaning your furniture regularly helps maintain its aesthetic appeal and extends its lifespan.

# Enjoy!

Join our community and be the first to see what's new!

Follow us on socials:



Quickly register your outdoor furniture purchase to activate your warranty and enjoy peace of mind with guaranteed product protection:



---

Have questions or need assistance? Reach out to our dedicated team at **(909) 284-1052** or email us at **[cs@seahawkdesigns.com](mailto:cs@seahawkdesigns.com)**.