

Scrubbing machines  
Autolaveuses de Sol  
Fregadora de Pavimentos

*ENG SPARE PARTS CATALOGUE*  
*FRA CATALOGUE DE PIECES DETACHEES*  
*ESP CATALOGO PIEZAS DE REPUESTO*

**HILLYARD**  
®

**SENTRY™**



**SUMMARY**

<b>SUMMARY</b> .....	<b>3</b>
<b>BRUSH BASE ASSEMBLY L=750mm L=29,5in (VER. RAL7016)</b> .....	<b>4</b>
<b>BRUSHES AND SQUEEGEE BASE CONTROL GROUP</b> .....	<b>8</b>
<b>SQUEEGEE ASSEMBLY L=38,94in (VER. AL)</b> .....	<b>18</b>
<b>GROUP CHASSIS MACHINE</b> .....	<b>20</b>
<b>BRAKE AND WHEELS ASSEMBLY</b> .....	<b>24</b>
<i>TRACTION WHEEL PRE-ASSEMBLING</i> .....	<b>28</b>
<b>TANKS ASSEMBLY (VER. RAL7016)</b> .....	<b>30</b>
<i>STEERING COLUMN COVER PRE-ASSEMBLING (VER. RAL7016)</i> .....	<b>32</b>
<i>SOLUTION TANK PREASSEMBLY (VER. RAL7016)</i> .....	<b>34</b>
<i>RECOVERY TANK ASSEMBLY (VER. RAL7016)</i> .....	<b>36</b>
<b>SUCTION MOTOR ASSEMBLY 24V 410W 2ST (VER. RAL7016)</b> .....	<b>38</b>
<b>WATER UNIT</b> .....	<b>40</b>
<b>ELECTRIC COMPONENTS ASSEMBLY (VER. 2SP)</b> .....	<b>42</b>
<b>GROUP OPTIONAL CHARGER</b> .....	<b>46</b>
<b>GROUP DECAL</b> .....	<b>48</b>

**SOMMAIRE**

<b>SOMMAIRE</b> .....	<b>3</b>
<b>GROUPE DE PLATEAU DES BROSSES L=750mm L=29,5in (VER. RAL7016)</b> .....	<b>4</b>
<b>GROUPE DE COMMANDE DE BROSSES ET BASE DE RACLETTE</b> .....	<b>8</b>
<b>GROUPE DE SUCEUR L=38,94in (VER. AL)</b> .....	<b>18</b>
<b>GROUPE CHASSIS MACHINE</b> .....	<b>20</b>
<b>GROUPE DE FREIN ET ROUES</b> .....	<b>24</b>
<i>ROUE DE TRACTION PRÉ-ASSEMBLAGE</i> .....	<b>28</b>
<b>GROUPE RESERVOIRS (VER. RAL7016)</b> .....	<b>30</b>
<i>PRE-ASSEMBLAGE DE COUVERCLE DE COLONNE DE DIRECTION (VER. RAL7016)</i> .....	<b>32</b>
<i>PRÉMONTAGE DE RESERVOIR EAU PROPRE (VER. RAL7016)</i> .....	<b>34</b>
<i>GROUPE DE RESERVOIR RECUPERATION (VER. RAL7016)</i> .....	<b>36</b>
<b>GROUPE MOTEUR DASPIRATION 24V 410W 2ST (VER. RAL7016)</b> .....	<b>38</b>
<b>GROUPE HYDRIQUE</b> .....	<b>40</b>
<b>GROUPE COMPOSANTS ELECTRIQUES (VER. 2SP)</b> .....	<b>42</b>
<b>GROUPE OPTIONNEL CHARGEUR DE BATTERIES</b> .....	<b>46</b>
<b>GROUPES DE ETIQUETTE</b> .....	<b>48</b>

**ÍNDICE**

<b>ÍNDICE</b> .....	<b>3</b>
<b>GRUPO BANCADA CEPILLO L=750mm L=29,5in (VER. RAL7016)</b> .....	<b>4</b>
<b>GRUPO MANDO CEPILLOS Y BASE LIMPIADORA</b> .....	<b>8</b>
<b>GRUPO LIMPIADOR DE SUELO L=38,94in (VER. AL)</b> .....	<b>18</b>
<b>GRUPO BASTIDOR DE LA MÁQUINA</b> .....	<b>20</b>
<b>GRUPO FRENO Y RUEDAS</b> .....	<b>24</b>
<i>RUEDA DE TRACCIÓN PRE-MONTAJE</i> .....	<b>28</b>
<b>GRUPO TANQUES (VER. RAL7016)</b> .....	<b>30</b>
<i>PRE-MONTAJE DE CUBIERTA COLUMNA DE DIRECCIÓN (VER. RAL7016)</i> .....	<b>32</b>
<i>PREMONTAJE TANQUE SOLUCIÓN (VER. RAL7016)</i> .....	<b>34</b>
<i>GRUPO TANQUE RECUPERACIÓN (VER. RAL7016)</i> .....	<b>36</b>
<b>GRUPO MOTOR SUCCION 24V 410W 2ST (VER. RAL7016)</b> .....	<b>38</b>
<b>GRUPO AGUA</b> .....	<b>40</b>
<b>GRUPO COMPONENTES ELÉCTRICOS (VER. 2SP)</b> .....	<b>42</b>
<b>GRUPO OPCIONAL CARGADOR DE BATERÍAS</b> .....	<b>46</b>
<b>GRUPOS ETIQUETA</b> .....	<b>48</b>

# CR-01 BRUSHES BASE ASSEMBLY

GRUPE PLATEAU DES BROSSES

GRUPO BANCADA CEPILLOS

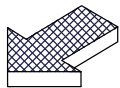
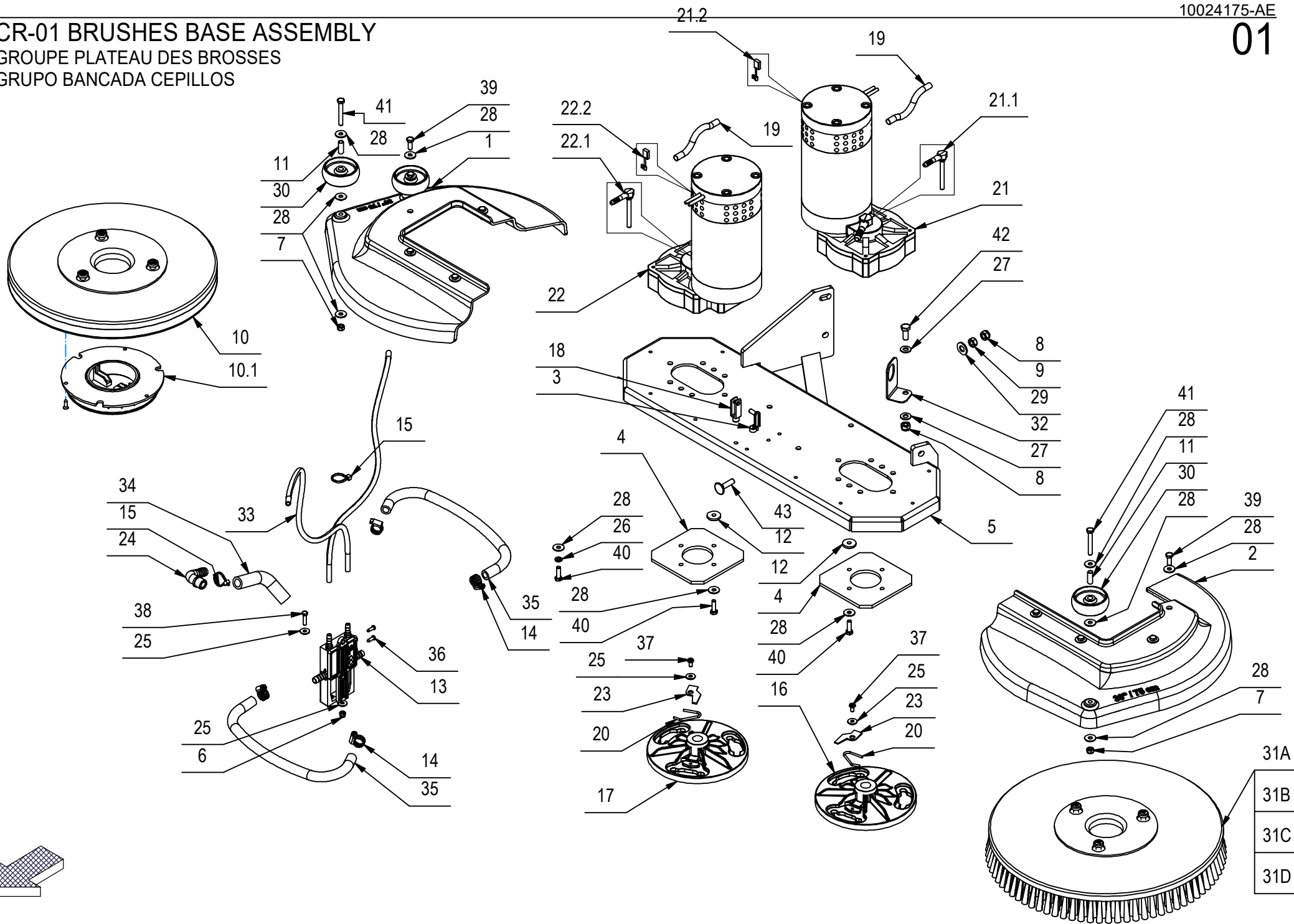

## CR-01 BRUSHES BASE ASSEMBLY

01

-	POS	TECHNICAL NEWS	SERIAL NUMBER	CODICE	QTÀ	DESCRIZIONE	DESCRIPTION	DESIGNATION	DESCRIPCIÓN
	1			430737	1	CARTER BASAMENTO DX D390 RAL 7016 MMG	BASE COVER	PROTECTION	PROTECCION BANCADA
	2			430736	1	CARTER BASAMENTO SX D390 RAL 7016 MMG	BASE COVER	PROTECTION	PROTECCION BANCADA
	3			410463	1	CLIPS PER FORCELLA M6X24 LUNGA	CLIP	CLIP	CLIP
	4			218998	2	CONTROPIASTRA MOTORIDUTTORE MMG	PLAQUE	PLAQUE	PLACA
	5			218994	1	CORPO BASAMENTO SPAZZOLE 65-75-85 MMG	BRUSHES BASE	EMBASE DES BROSSES	BANCADA CEPILLOS
	6			409080	2	DADO M5x7 AUTOBL. UNI 7473 ZINC	NYLOCK M5x7 UNI 7473 ZINC	ECROU AUTOFREINES	TUERCA AUTOBLOCANTE
	7			409082	3	DADO M6 UNI 7474 ZINC	NUT M6 UNI 7474 ZINC	ECROU AUTOFREINES	TUERCA AUTOBLOCANTE
	8			409085	2	DADO M8 UNI 7474 - ZINC	NUT M8 UNI 7474 - ZINC	ECROU AUTOFREINES M8 UNI 7474 - ZINC	TUERCA AUTOBLOCANTE M8 UNI 7474 - ZINC
	9			409046	1	DADO M8x6,5 UNI 5588 ZINC	NUT M8x6,5 UNI 5588 ZINC	ECROU	TUERCA
↓	10			427718	1	DISCO TRASCINATORE Df=14,96in	PAD HOLDER Df=14.96 in		
↑	10.1			410575	1	CENTER LOCK H=20 (VITE COLORE VERDE)	CENTER LOCK H=20 (SCREW GREEN COLOR)		
	11			407976	3	DISTANZIALE D=8 d=6,25 S=21 OT63	SPACER	ENTRETOISE	DISTANCIADOR
	12			203245	4	DISTANZIALE D=22 d=6.5 S=4 AVP	SPACER	ENTRETOISE	DISTANCIADOR
	13			442057	1	DISTRIBUTORE BASAMENTO BISPAZZOLA	DISTRIBUTOR	DISTRIBUTEUR	DISTRIBUIDOR
	14			410292	4	FASCETTA A VITE 11/17 ABA	HOSE CLAMP 11/17 ABA	COLLIER A VIS 11/17 ABA	ABRAZADERA DE TORNILLO 11/17 ABA
	15			410274	2	FASCETTA PLASTICA 2.5x98	CLAMP 2.5x98	COLLIER	ABRAZADERA
	16			432020	1	FLANGIA DESTRA ATTACCO SPAZZOLA D=128	FLANGE	FLASQUE	BRIDA
	17			432021	1	FLANGIA SINISTRA ATTACCO SPAZZOLA D=128	FLANGE	FLASQUE	BRIDA
	18			410455	1	FORCELLA M6X24 UNI 1676 LUNGA	FORK	FOURCHETTE	HORQUILLA
	19			202116	2	GUAINA TERMOR.9,5X300	SHEATH	GAINÉ	VAINA
	20			408128	2	MOLLA BLOCCAGGIO SPAZZOLA	SPRING	RESSORT	RESORTE
↓	21			438563	1	MOTORID. 24V 500W 140RPM ALBERO FIL. DX	GEARED MOTOR ASSEMBLY	MOTO-REDUCTEUR COMPLET	MOTORREDUCTOR COMPLETO
↑	21.1			423060	1	PORTAGOMMA ESAGONALE FILET. G1/4 MASCHIO	FITTING HEXAGON THREAD G1/4 M	RACCORD FILETAGE HEXAGONAL G1/4 M	RACOR ROSCA HEXAGONAL G1/4 M
↑	21.2			422462	4	SPAZZOLA MOTORE 7X14X19 (FASTON)	MOTOR BRUSH 7X14X19 (FASTON)	BROSSE MOTEUR 7X14X19 (FASTON)	CEPILLO MOTOR 7X14X19 (FASTON)
↓	22			438300	1	MOTORID. 24V 500W 140RPM ALBERO FIL. SX	GEARED MOTOR ASSEMBLY 24V 500W 140RPM S	MOTO-REDUCTEUR COMPLET 24V 500W 140RPM S	MOTORREDUCTOR COMPLETO 24V 500W 140RPM S
↑	22.1			423060	1	PORTAGOMMA ESAGONALE FILET. G1/4 MASCHIO	FITTING HEXAGON THREAD G1/4 M	RACCORD FILETAGE HEXAGONAL G1/4 M	RACOR ROSCA HEXAGONAL G1/4 M
↑	22.2			422462	4	SPAZZOLA MOTORE 7X14X19 (FASTON)	MOTOR BRUSH 7X14X19 (FASTON)	BROSSE MOTEUR 7X14X19 (FASTON)	CEPILLO MOTOR 7X14X19 (FASTON)
	23			203268	2	PIASTRINA DI SICUREZZA	PLAQUE	PLAQUETTE	PLAQUETA
	24			410349	1	PORTAGOMMA A GOMITO 3/8"x12-13	CONNECTOR	RACCORD	EMPALME TUBO DE GOMA

CR-01 BRUSHES BASE ASSEMBLY

GROUPE PLATEAU DES BROSSES

GRUPO BANCADA CEPILLOS

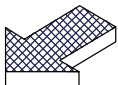
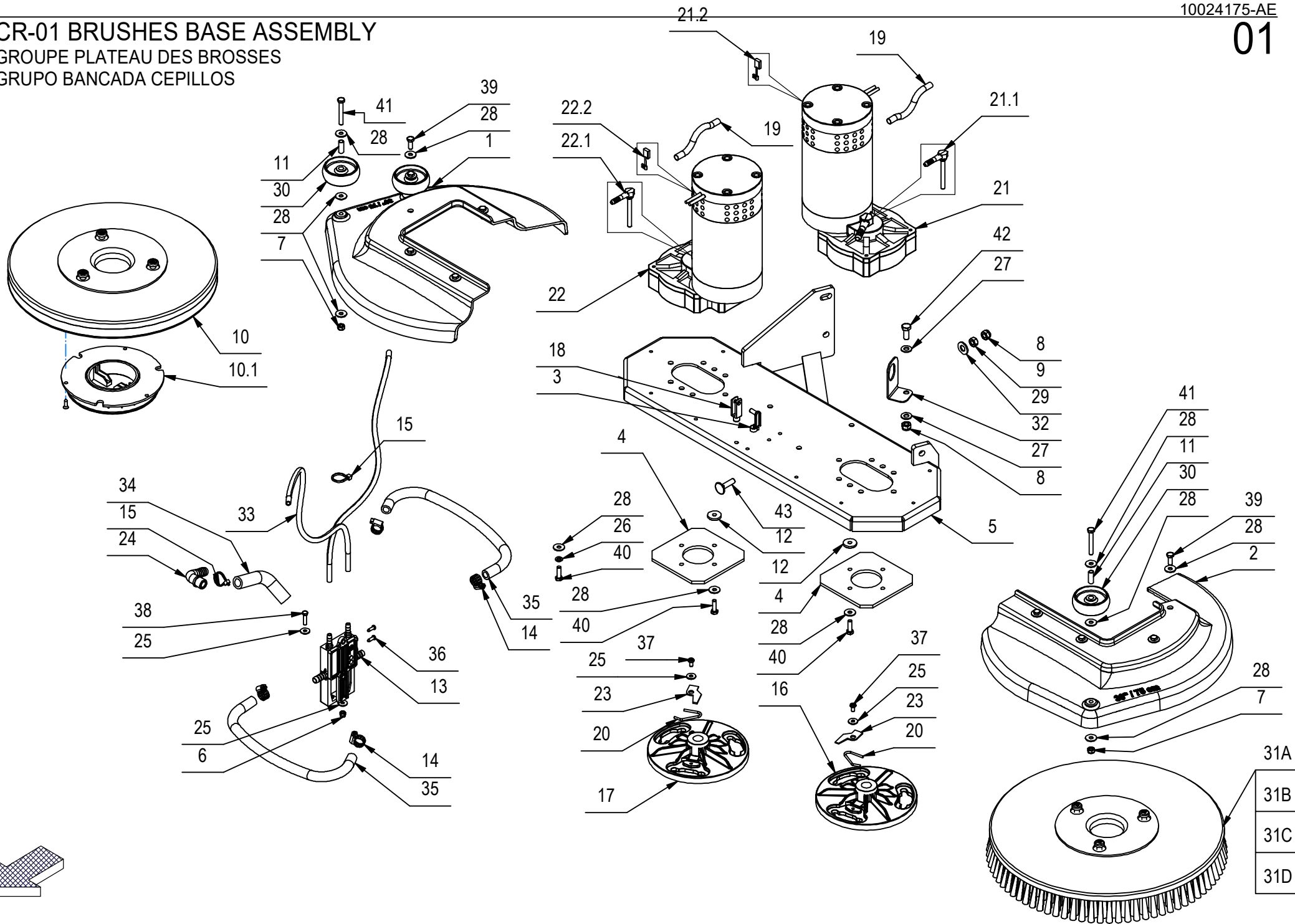

## CR-01 BRUSHES BASE ASSEMBLY

01

-	POS	TECHNICAL NEWS	SERIAL NUMBER	CODICE	QTÀ	DESCRIZIONE	DESCRIPTION	DESIGNATION	DESCRIPCION
	25			409151	6	RONDELLA 5,5x15x1.5 UNI 6593 ZINC	WASHER 5,5x15x1.5 UNI 6593 ZINC	RONDELLE	ARANDELA
	26			409164	1	RONDELLA D11,8 UNI 1751 ZINC	WASHER D11,8 UNI 1751 ZINC	RONDELLE FREIN	ARANDELLA DENTADA
	27			409175	2	RONDELLA D17 UNI 6592 ZINC.	WASHER D17 UNI 6592 ZINC.	RONDELLE M8 UNI 6592 ZINC	ARANDELA M8 UNI 6592 ZINC
	28			409160	26	RONDELLA D18 UNI 6593 ZINC	WASHER D18 UNI 6593 ZINC	RONDELLE	ARANDELA
	29			409191	1	RONDELLA D21 UNI 6592 ZINC	WASHER D21 UNI 6592 ZINC	RONDELLE	ARANDELA
	30			209269	3	RUOTINA D=60 H=21 PLASTICA NERA	WHEEL	ROUE	RUEDA
	31A			427715	1	SPAZZOLA De=15,35in Df=14,96in PPL0,011in (COLORE CIANO)	BRUSH De=15.35 in Df=14.96 in PPL0.011 in (CYAN COLOR)	BROSSE De=15,35 po Df=14,96 po PPL0,011 po (COULEUR CYAN)	CEPILLO De=15.35 in Df=14.96 in PPL0.011 in (COLOR CIAN)
	31B			427716	2	SPAZZOLA De=15,35in Df=14,96in PPL0,023in (COLORE BIANCO)	BRUSH De=15.35 in Df=14.96 in PPL0.023 in (WHITE COLOR)	BROSSE De=15,35 po Df=14,96 po PPL0,023 po (COULEUR BLANCHE)	CEPILLO De=15.35 in Df=14.96 in PPL0.023 in (COLOR BLANCO)
	31C			427717	1	SPAZZOLA De=15,35in Df=14,96in PPL0,035in (COLORE NERO)	BRUSH De=15.35 in Df=14.96 in PPL0.035 in (BLACK COLOR)	BROSSE De=15,35 po Df=14,96 po PPL0,035 po (COULEUR NOIRE)	CEPILLO De=15.35 in Df=14.96 in PPL0.035 in (COLOR NEGRO)
	31D			427719	1	SPAZZOLA De=15,35in Df=14,96in FIBRE ARTIFICIALI	BRUSH De=15.35 in Df=14.96 in ARTIFICIAL FIBERS	BROSSE De=15,35 en Df=14,96 en FIBRES ARTIFICIELLES	CEPILLO De=15.35 in Df=14.96 in FIBRAS ARTIFICIALES
	32			216281	1	STAFFA FISSAGGIO FILTRO MAXIMA 2008	SUPPORT	ATTAQUE	SOPORTE FIJADOR
	33			216307	2	TUBO D=8 d=5 L=500 VITREO	PIPE	TUBE	TUBO
	34			219253	1	TUBO Di=13 De=20 L=120 PVC	PIPE	TUBE	TUBO
	35			217607	2	TUBO DIAM.10X330 PVC SPIR. TRASPARENTE	PIPE	TUBE	TUBO
	36			408876	2	VITE D.3.9x13 AUTOF. UNI 6954 A2	SCREW	VIS	TORNILLO
	37			408848	2	VITE M5X10 UNI 7687 AISI	SCREW M5X10 UNI 7687 AISI	VIS	TORNILLO
	38			407647	2	VITE M5x20 TE UNI 5739 ZINC	SCREW M5X20 UNI 5739 ZINC	VIS M5X20 UNI 5739 ZINC	TORNILLO M5X20 UNI 5739 ZINC
	39			407663	8	VITE M6x16 TE UNI 5739 ZINC	SCREW	VIS	TORNILLO
	40			407666	9	VITE M6X20 UNI 5739 ZINC	SCREW M6X20 UNI 5739 ZINC	VIS	TORNILLO
	41			415719	3	VITE M6x45 TE UNI 5739 ZINCATA	SCREW	VIS	TORNILLO
	42			408670	1	VITE M8x20 UNI 5739 ZINC	SCREW M8x20 UNI 5739 ZINC	VIS	TORNILLO
	43			412133	1	VITE M8x30 TTQST UNI 5732 ZINC	SCREW	VIS	TORNILLO

# CR-02/04 BRUSHES AND SQUEEGEE BASE CONTROL GROUP

GROUPE DE COMMANDE DE BROSSES ET BASE DE RACLETTE  
GRUPO MANDO CEPILLOS Y BASE LIMPIADORA

# 02/04

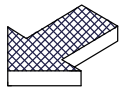
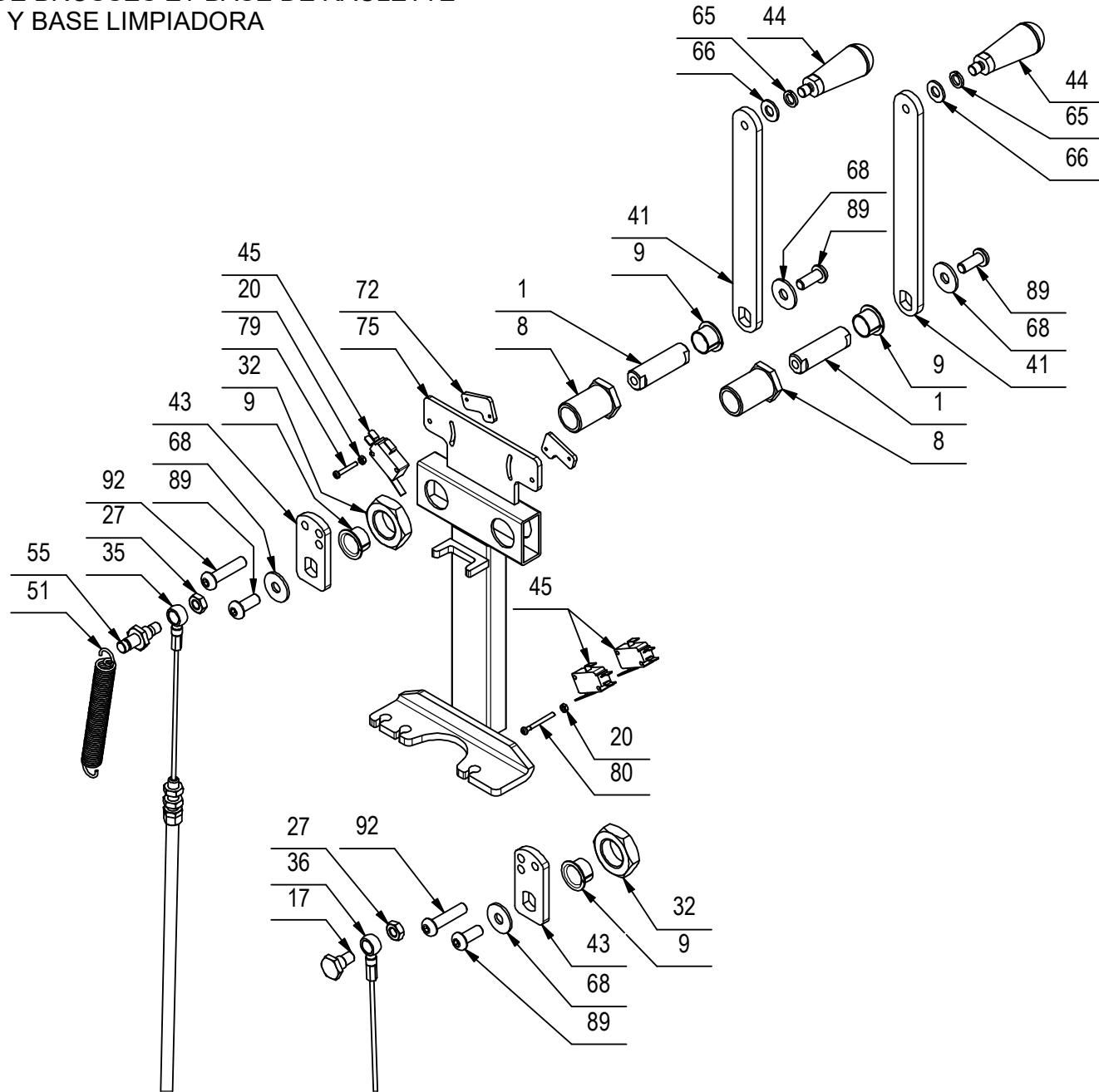



## CR-02/04 BRUSHES AND SQUEEGEE BASE CONTROL GROUP

02/04

-	POS	TECHNICAL NEWS	SERIAL NUMBER	CODICE	QTÀ	DESCRIZIONE	DESCRIPTION	DESIGNATION	DESCRIPCÓN
	1			219114	2	ALBERO LEVE SOLLEVAMENTO MR	SHAFT	ARBRE	EJE
	8			219110	2	BOCCOLA D=CH27-M24 d=18 S=39 C40	BUSHING	BAGUE	CASQUILLO
	9			408058	4	BOCCOLA LAMEL. Ø18 x ø16 x H12 COLL. Ø24	BUSHING	BAGUE	CASQUILLO
	17			203269	1	COLONNETTA PER GIUNTO	STUD BOLT	TIGE	PRISIONERO
	20			415882	4	DADO M3x2,5 UNI 5588 ZINC.	NUT M3x2,5 UNI 5588 ZINC.	ECROU	TUERCA
	27			409054	2	DADO M8x5 UNI 5589 ZINC	NUT M8x5 UNI 5589 ZINC	ECROU	TUERCA
	32			409076	2	DADO M24x2 UNI 5589	NUT	ECROU	TUERCA
	35			430911	1	FUNE SOLLEVAMENTO BASAMENTO MR	CABLE	CABLE	CUERDA
	36			430912	1	FUNE SOLLEVAMENTO TERGIPAVIMENTO MR	CABLE	CABLE	CUERDA
	41			219112	2	LEVA ESTERNA SOLLEVAMENTO MR	LEVER	LEVIER	PALANCA
	43			219113	2	LEVA INTERNA SOLLEVAMENTO MR	LEVER	LEVIER	PALANCA
	44			430991	2	MANOPOLA CONICA GIREVOLE M8 GAMM	KNOB	POIGNEE	EMPUÑADURA
	45			409499	3	MICRO 16A 3x22 LEVA CORTA	MICROSWITCH	MICROINTERRUPTEUR	MICROINTERRUPTOR
	51			219083	1	MOLLA TRAZIONE 15x2x122 - 98 N°49 SPIRE	SPRING	RESSORT	RESORTE
	55			219383	1	PERNO M8 CH17 L=38,5	PIN	AXE	PERNO
	65			409181	2	RONDELLA D13 UNI 1751 ZINC	LOCK WASHER D13 UNI 1751 ZINC	RONDELLE FREIN	ARANDELLA DENTADA
	66			409175	2	RONDELLA D17 UNI 6592 ZINC.	WASHER D17 UNI 6592 ZINC.	RONDELLE M8 UNI 6592 ZINC	ARANDELA M8 UNI 6592 ZINC
	68			409179	11	RONDELLA D24 UNI 6593 ZINC	WASHER D24 UNI 6593 ZINC	RONDELLE M8 UNI 6593 ZINC	ARANDELA M8 UNI 6593 ZINC
	72			219111	2	STAFFETTA FERMA RELE' SOLLEV. MAN. MMG	SUPPORT	ATTAQUE	SOPORTE FIJADOR
	75			219115	1	SUPPORTO LEVE SOLLEVAMENTO MR	SUPPORT	SUPPORT	SOPORTE
	79			408834	4	VITE M3X20 UNI 7687 ZINC	SCREW M3X20 UNI 7687 ZINC	VIS	TORNILLO
	80			408836	2	VITE M3x30 TCTC UNI 7687 ZINC	SCREW	VIS	TORNILLO
	89			425828	4	VITE M8x20 TBEI ISO 7380 A2	SCREW	VIS	TORNILLO
	92			416779	2	VITE M8x35 TBEI ISO 7380 ZINC	SCREW	VIS	TORNILLO

# CR-02/04 BRUSHES AND SQUEEGEE BASE CONTROL GROUP

GROUPE DE COMMANDE DE BROSSES ET BASE DE RACLETTE

GRUPO MANDO CEPILLOS Y BASE LIMPIADORA

# 02/04

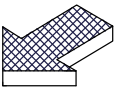
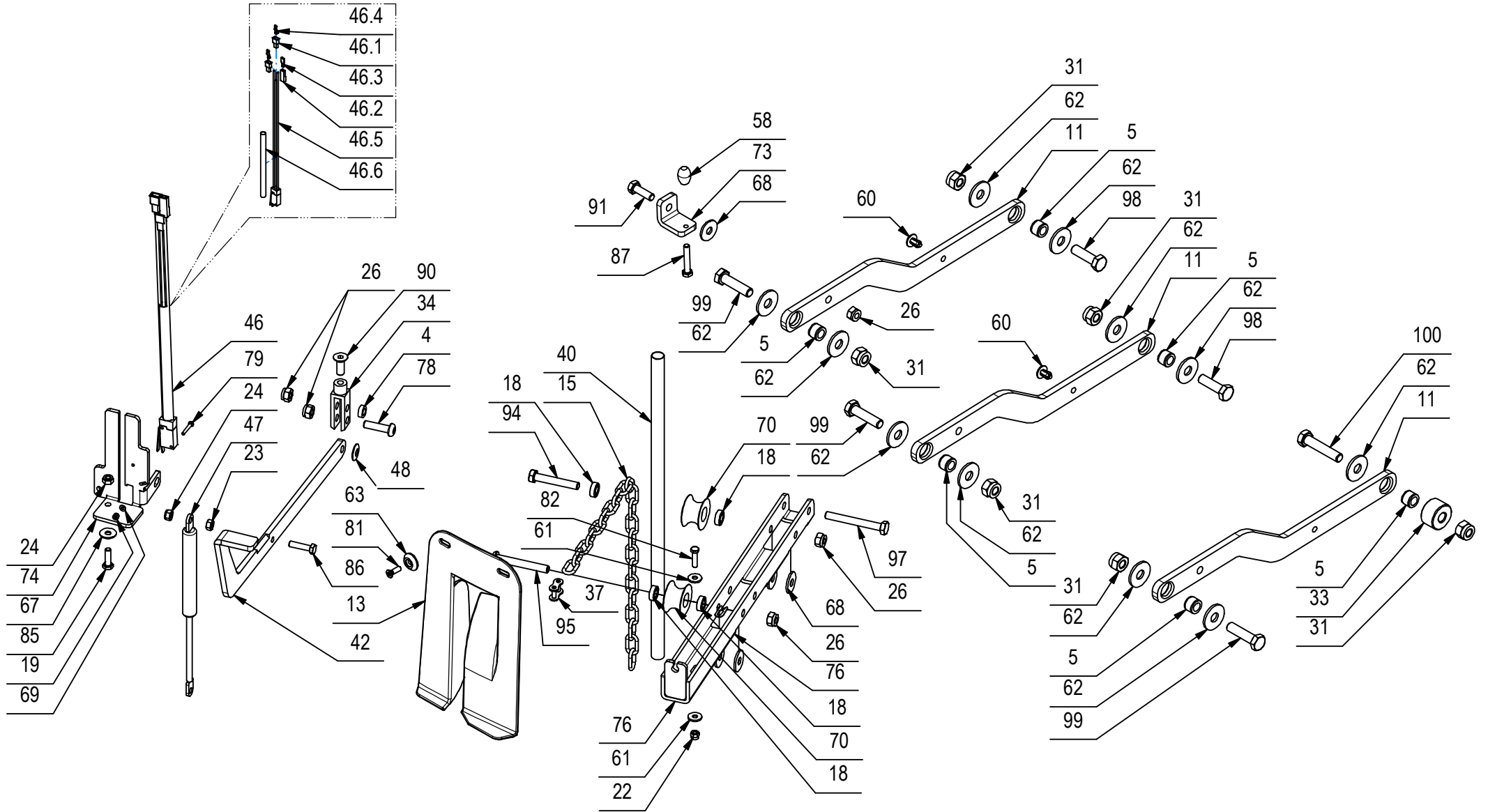

## CR-02/04 BRUSHES AND SQUEEGEE BASE CONTROL GROUP

02/04

-	POS	TECHNICAL NEWS	SERIAL NUMBER	CODICE	QTÀ	DESCRIZIONE	DESCRIPTION	DESIGNATION	DESCRIPCIÓN
	4			408016	1	BOCCOLA D=13 d=8 S=4,5 OT58	BUSHING D=13 d=8 S=4,5 OT58	BAGUE	CASQUILLO
	5			408038	6	BOCCOLA D=15,9 d=10 S=11,5 OT58	BUSHING	BAGUE	CASQUILLO
	11			218940	3	BRACCIO BASAMENTO MMG	ARM	BRAS	BRAZO
	13			431284	1	CARTER EXTRA PRESSIONE APERTO MMG	COVER	CARTER	CARTER
	15			221462	1	CATENA NR.18 - LUNGHEZZA INTERNA = 440	CHAIN	CHAINE	CADENA
	18			411950	6	CUSCINETTO A SFERE 688 ZZ (8x16 H=5)	BEARING 688 ZZ (8x16 H=5)	ROULEMENT	COJINETE
	19			415897	2	DADO M3 UNI 7474 AISI	NUT M3 UNI 7474 AISI	ECROU AUTOBLOCANT	TUERCA AUTOBLOCANTE
	22			409080	1	DADO M5x7 AUTOBL. UNI 7473 ZINC	NYLOCK M5x7 UNI 7473 ZINC	ECROU AUTOFREINES	TUERCA AUTOBLOCANTE
	23			409040	3	DADO M6 UNI 5588 ZINC	NUT M6 UNI 5588 ZINC	ECROU	TUERCA
	24			409082	5	DADO M6 UNI 7474 ZINC	NUT M6 UNI 7474 ZINC	ECROU AUTOFREINES	TUERCA AUTOBLOCANTE
	26			409085	7	DADO M8 UNI 7474 - ZINC	NUT M8 UNI 7474 - ZINC	ECROU AUTOFREINES M8 UNI 7474 - ZINC	TUERCA AUTOBLOCANTE M8 UNI 7474 - ZINC
	31			409089	7	DADO M10x12 UNI 7473 ZINC	NUT M10x12 UNI 7473 ZINC	ECROU AUTOFREINES	TUERCA AUTOBLOCANTE
	33			219180	1	DISTANZIALE D=30 d=10,5 L=18,5 AVP	SPACER	ENTRETOISE	DISTANCIADOR
	34			222942	1	FORCELLA M8x32 UNI 1676 LAVORATA	FORK	FOURCHETTE	HORQUILLA
	37			408380	1	GIUNTO CATENA DA 1/2	JOINT CHAIN	ATTACHE RAPIDE CHAINE	ACOPLAMIENTO CADENA
	40			221463	1	GUAINA TERMORESTRING. D.12,7 NERA L=400	SHEATH	GAINÉ	VAINA
	42			218993	1	LEVA EXTRA PESO BASAMENTO MMG	LEVER	LEVIER	PALANCA
↓	46			216999	1	MICROINT. ABV1612613 + FASTON	MICROSWITCH	MICROINTERRUPTEUR	MICROINTERRUPTOR
↑	46.1			427681	1	MICROINT. ABV1612613 C/LAMA PIATTA	MICROSWITCH	MICROINTERRUPTEUR	MICROINTERRUPTOR
↑	46.2			409890	1	FASTON FEMMINA 6,3 NUDO	FASTON FEMALE 6,3	FEMELLE FASTON	FASTON HEMBRA
↑	46.3			416087	2	FASTON MASCHIO NUDO D.6,3	FASTON	FASTON	FASTON
↑	46.4			416138	1	COPRIFASTON X FEMMINA D.6.3 25X9 BIAN	FEMALE FASTON COVER	COUVERCLE DE FASTON	CUBREFASTON
↑	46.5			209449	1	TUBETTO RESTRINGIBILE 9,5X150	SHEATH	GAINÉ	VAINA
↑	46.6			409951	2	COPRIFASTON MASCHIO 6,3	FASTON COVER	COUVERCLE DE FASTON	CUBREFASTON
	47			414748	1	MOLLA A GAS OC-OC D6x15 F300N I226.5 C8	GAS SHOCK ABSORBER	RESSORT	AMORTIGUADOR A GAS
	48			409178	1	MOLLA A TAZZA 8x18x1	CUPPED WASHER	RONDELLE CONCAVE	ARANDELA CONCAVA
	58			409859	1	PIEDINO A BOTTE d=6	RUBBER CAP	BOUCHON DE CAOUTCHOUC	TAPON DE GOMA
	60			415952	2	RIVETTO 6.4X10 NYLON	RIVET	RIVET	CLAVO
	61			409151	2	RONDELLA 5,5x15x1.5 UNI 6593 ZINC	WASHER 5,5x15x1.5 UNI 6593 ZINC	RONDELLE	ARANDELA
	62			409194	14	RONDELLA 11x30x2,5 UNI 6593 ZINC	WASHER 11x30x2,5 UNI 6593 ZINC	RONDELLE	ARANDELA
	63			400250	2	RONDELLA D=5X20	SPECIAL WASHER D=5X20	RONDELLE SPECIALE	ARANDELA ESPECIAL
	67			409160	3	RONDELLA D18 UNI 6593 ZINC	WASHER D18 UNI 6593 ZINC	RONDELLE	ARANDELA
	68			409179	11	RONDELLA D24 UNI 6593 ZINC	WASHER D24 UNI 6593 ZINC	RONDELLE M8 UNI 6593 ZINC	ARANDELA M8 UNI 6593 ZINC
	69			415917	2	RONDELLA M3 UNI 6592 ZINC	WASHER M3 UNI 6592 ZINC	RONDELLE	ARANDELA
	70			415242	3	RULLINO DIAM.35	ROLLER DIAM.35	ROULEAU	RODILLO
	73			218958	1	STAFFETTA GUIDA BRACCIO BASAMENTO MMG	SUPPORT	ATTAQUE	SOPORTE FIJADOR

# CR-02/04 BRUSHES AND SQUEEGEE BASE CONTROL GROUP

GROUPE DE COMMANDE DE BROSSES ET BASE DE RACLETTE  
GRUPO MANDO CEPILLOS Y BASE LIMPIADORA

# 02/04

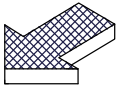
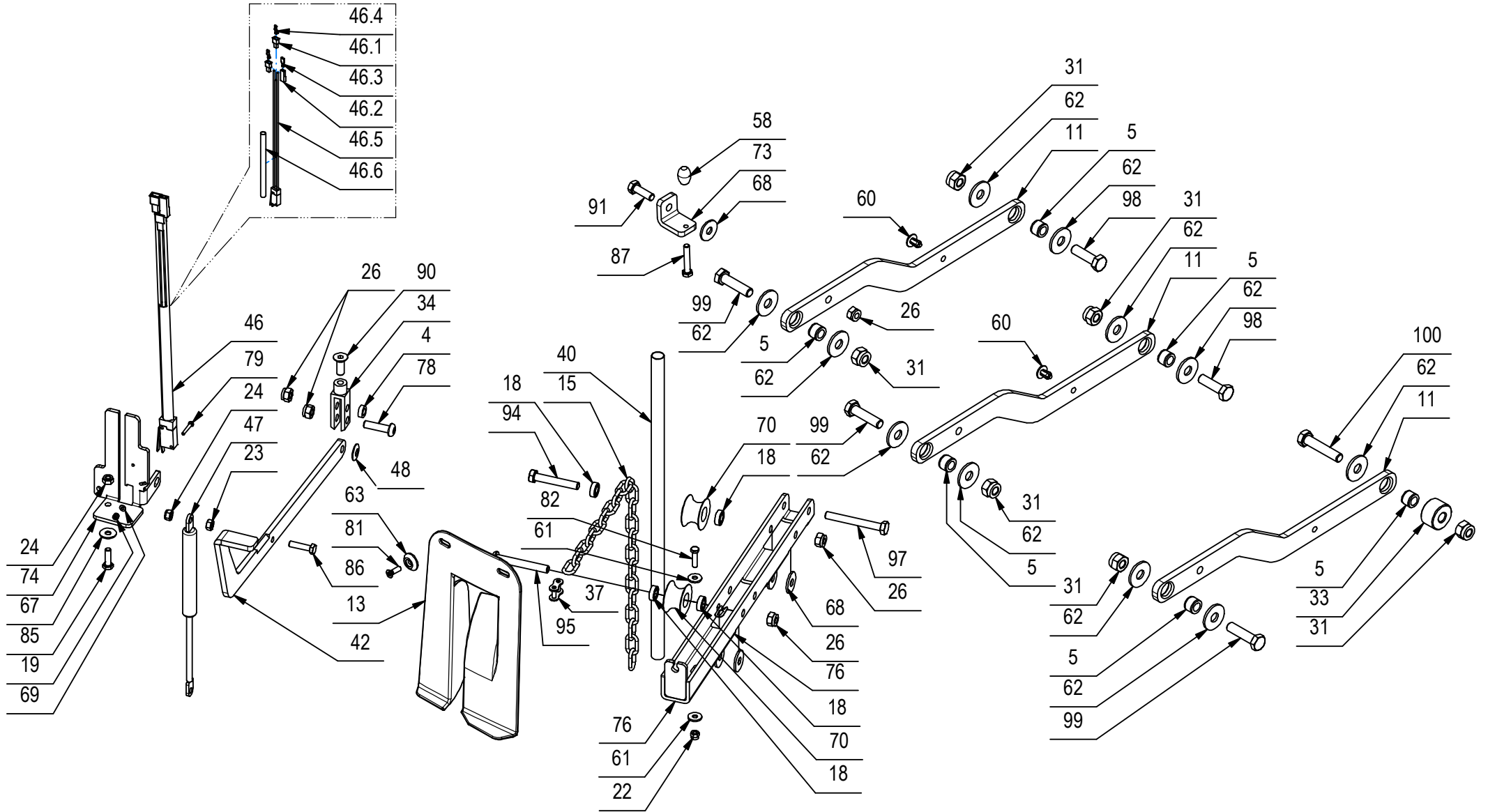

## CR-02/04 BRUSHES AND SQUEEGEE BASE CONTROL GROUP

02/04

-	POS	TECHNICAL NEWS	SERIAL NUMBER	CODICE	QTÀ	DESCRIZIONE	DESCRIPTION	DESIGNATION	DESCRIPCIÓN
	74			222945	1	STAFFETTA MICRO EXTRA-PRESSIONE MR	SUPPORT	SUPPORT	SOPORTE
	76			219084	1	SUPPORTO SOLLEVAMENTO BASAMENTO MR	SUPPORT	SUPPORT	SOPORTE
	78			415860	1	VITE 8X30 ISO 7380 ZINC. TCBEI	SCREW	VIS	TORNILLO
	79			408834	4	VITE M3X20 UNI 7687 ZINC	SCREW M3X20 UNI 7687 ZINC	VIS	TORNILLO
	81			408516	2	VITE M5x16 TSCTC UNI 7689 ZINC	SCREW	VIS	TORNILLO
	82			407647	1	VITE M5x20 TE UNI 5739 ZINC	SCREW M5X20 UNI 5739 ZINC	VIS M5X20 UNI 5739 ZINC	TORNILLO M5X20 UNI 5739 ZINC
	85			407666	1	VITE M6X20 UNI 5739 ZINC	SCREW M6X20 UNI 5739 ZINC	VIS	TORNILLO
	86			407669	2	VITE M6x25 TE UNI 5739 ZINC	SCREW	VIS	TORNILLO
	87			408651	2	VITE M6x35 TE UNI 5739 ZINC	SCREW	VIS	TORNILLO
	90			408981	1	VITE M8x22 TPSEI UNI5933 ZINC	SCREW	VIS	TORNILLO
	91			408674	1	VITE M8x25 UNI 5739 ZINC	SCREW M8x25 UNI 5739 ZINC	VIS	TORNILLO
	94			408692	1	VITE M8X50 UNI 5739 ZINC	SCREW M8X50 UNI 5739 ZINC	VIS	TORNILLO
	95			412434	1	VITE M8X60 ISO 7380 ZINC	SCREW M8X60 ISO 7380 ZINC	VIS	TORNILLO
	97			408685	1	VITE M8X65 TE UNI5737 FP ZINC	SCREW	VIS	TORNILLO
	98			408714	2	VITE M10x35 TE UNI 5739 ZINC	SCREW	VIS	TORNILLO
	99			408715	4	VITE M10x40 TE UNI 5739 (8.8)	SCREW	VIS	TORNILLO
	100			408724	1	VITE M10X50 TE UNI 5739 ZINC	SCREW	VIS	TORNILLO

# CR-02/04 BRUSHES AND SQUEEGEE BASE CONTROL GROUP

GRUPE DE COMMANDE DE BROSSES ET BASE DE RACLETTE  
GRUPO MANDO CEPILLOS Y BASE LIMPIADORA

# 02/04

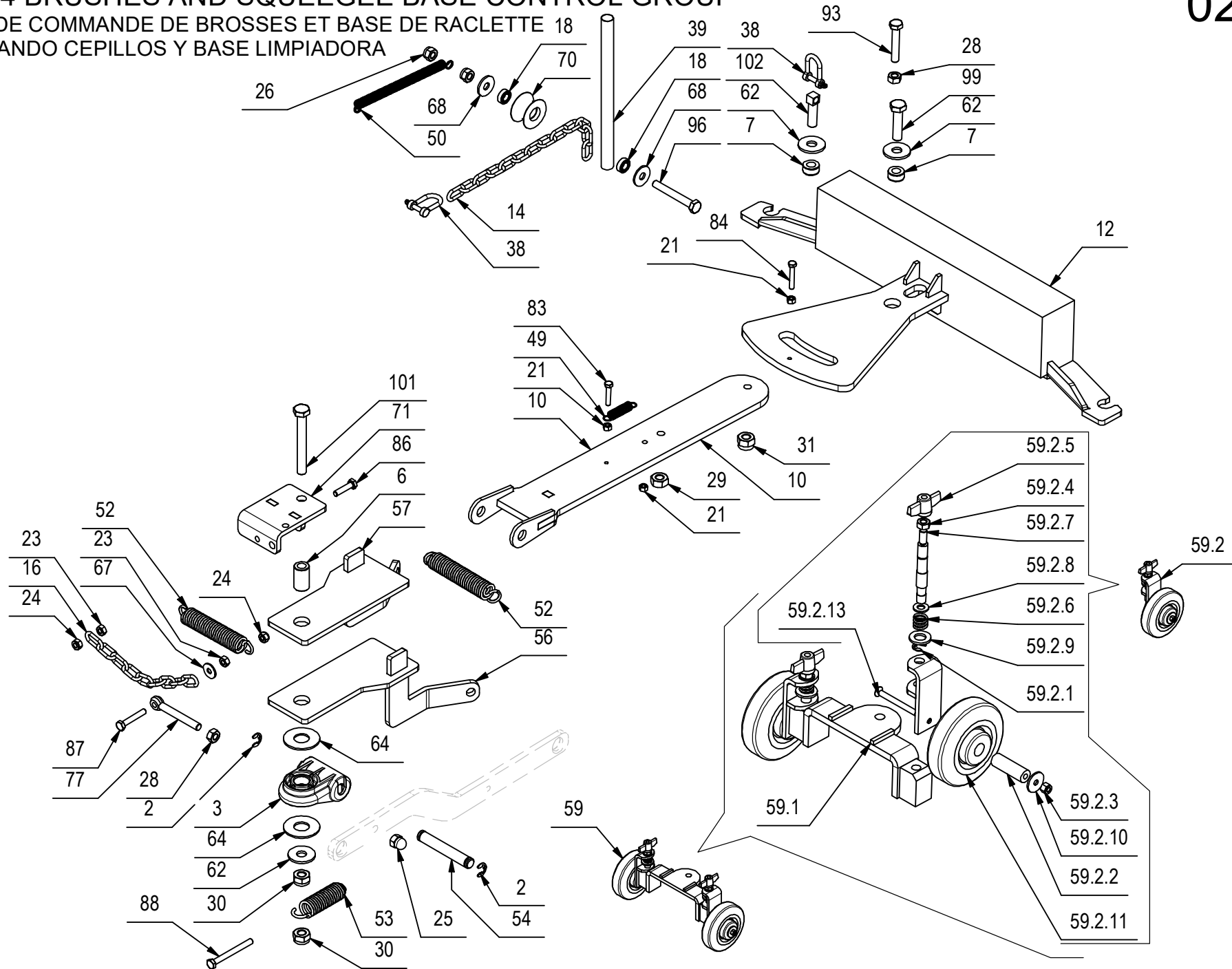

## CR-02/04 BRUSHES AND SQUEEGEE BASE CONTROL GROUP

02/04

-	POS	TECHNICAL NEWS	SERIAL NUMBER	CODICE	QTÀ	DESCRIZIONE	DESCRIPTION	DESIGNATION	DESCRIPCIÓN
	2			408371	2	ANELLO SEEGER RS9 DIN 6799	RING	ANNEAU	ANILLO
	3			400838	1	ATTACCO TERGIPAVIMENTO SIMPLA	COUPLING	ATTAQUE	ACOPLAMIENTO
	6			430353	1	BOCCOLA D=17 d=10 S=28,5 OTTONE	BUSHING	BAGUE	CASQUILLO
	7			411769	2	BOCCOLA D=18 d=10 S=8,5 OT58	BUSHING	BAGUE	CASQUILLO
	10			218923	1	BRACCIO ANTERIORE TERGI MMG	ARM	BRAS	BRAZO
	12			223096	1	BRACCIO POSTERIORE TERGI MMG-INNOVA 2013	ARM	BRAS	BRAZO
	14			219390	1	CATENA NR.18 - LUNGHEZZA INTERNA = 260	CHAIN	CHAINE	CADENA
	16			206100	1	CATENA NR.18 ZINCATA L=198 9 ANELLI	CHAIN	CHAINE	CADENA
	18			411950	6	CUSCINETTO A SFERE 688 ZZ (8x16 H=5)	BEARING 688 ZZ (8x16 H=5)	ROULEMENT	COJINETE
	21			409036	3	DADO M5x5 UNI 5587 ZINC	NUT M5x5 UNI 5587 ZINC	ECROU	TUERCA
	23			409040	3	DADO M6 UNI 5588 ZINC	NUT M6 UNI 5588 ZINC	ECROU	TUERCA
	24			409082	5	DADO M6 UNI 7474 ZINC	NUT M6 UNI 7474 ZINC	ECROU AUTOFREINES	TUERCA AUTOBLOCANTE
	25			409110	1	DADO M8 CIECO CON CALOTTA UNI 5721 ZINC	CAP NUT M8 ZNT	ÉCROU BORGNE M8 ZNT	DADO CIECO M8 ZNT OT.H-12mm
	26			409085	7	DADO M8 UNI 7474 - ZINC	NUT M8 UNI 7474 - ZINC	ECROU AUTOFREINES M8 UNI 7474 - ZINC	TUERCA AUTOBLOCANTE M8 UNI 7474 - ZINC
	28			409046	2	DADO M8x6,5 UNI 5588 ZINC	NUT M8x6,5 UNI 5588 ZINC	ECROU	TUERCA
	29			415889	1	DADO M10 UNI 5588-65 ZINC. MEDIO	NUT	ECROU	TUERCA
	30			409090	2	DADO M10 UNI 7474 ZINC	LOCK NUT M10 UNI 7474 ZINC	ECROU AUTOFREINES	TUERCA AUTOBLOCANTE
	31			409089	7	DADO M10x12 UNI 7473 ZINC	NUT M10x12 UNI 7473 ZINC	ECROU AUTOFREINES	TUERCA AUTOBLOCANTE
	38			410325	2	GRILLO ZINCATO M5	SPLIT PIN	GOUPILLE	PASADOR DE ALETAS
	39			217530	1	GUAINA TERMORESTRING. D.12,7 NERA L=200	HEATSHRINKABLE PIPE D.12,7 NERA L=200	GAINÉ	VAINA
	49			202480	1	MOLLA TRAZ. 10X1,1X46 ZINC	SPRING 10X1,1X46 ZINC	RESSORT	RESORTE
	50			408123	1	MOLLA TRAZ. 10x1x103	SPRING	RESSORT	RESORTE
	52			408110	2	MOLLA TRAZIONE 20x2,8x109	SPRING	RESSORT	RESORTE
	53			202479	1	MOLLA TRAZIONE 20x3x48+15	TRACTION SPRING	TRACTION RESSORT	RESORTE TRACCION
	54			218934	1	PERNO D=12 L=78 Fe360B ZINCATO	PIN	AXE	PERNO
	56			218932	1	PIASTRA INFER. EXTRA ROTAZIONE TERGI MMG	PLAQUE	PLAQUE	PLACA
	57			218929	1	PIASTRA SUPER. EXTRA ROTAZIONE TERGI MMG	PLAQUE	PLAQUE	PLACA
↓	59			223082	1	PREM. ATTACCO REG. TERGI MMG-INNOVA 2013	ADJUSTING SQUEEGEE KIT INNOVA	RÉGLAGE KIT SUCEUR	AJUSTE DEL KIT LIMPIAPAVIMENTOS
↑	59.1			437782	1	ATTACCO REG. TERGI MMG-INNOVA 2013	COUPLING	ATTAQUE	ACOPLAMIENTO
↑↓	59.2			223081	2	PREM. SUPP. RUOTA TERGI MMG-INNOVA 2013	SUPPORT WHEEL ASSY	GROUPE SUPPORT ROUE	GRUPO SOPORTE RUEDA
↑↑	59.2.1			408371	1	ANELLO SEEGER RS9 DIN 6799	RING	ANNEAU	ANILLO
↑↑	59.2.2			437792	1	BOCCOLA D=15 d=6,2 S=46 AVP	BUSHING	BAGUE	CASQUILLO
↑↑	59.2.3			409083	1	DADO M6x8 AUTOBL. UNI 7473 DIN 982 A2	NUT	ECROU	TUERCA
↑↑	59.2.4			409046	1	DADO M8x6,5 UNI 5588 ZINC	NUT M8x6,5 UNI 5588 ZINC	ECROU	TUERCA

# CR-02/04 BRUSHES AND SQUEEGEE BASE CONTROL GROUP

GRUPE DE COMMANDE DE BROSSES ET BASE DE RACLETTE  
GRUPO MANDO CEPILLOS Y BASE LIMPIADORA

# 02/04

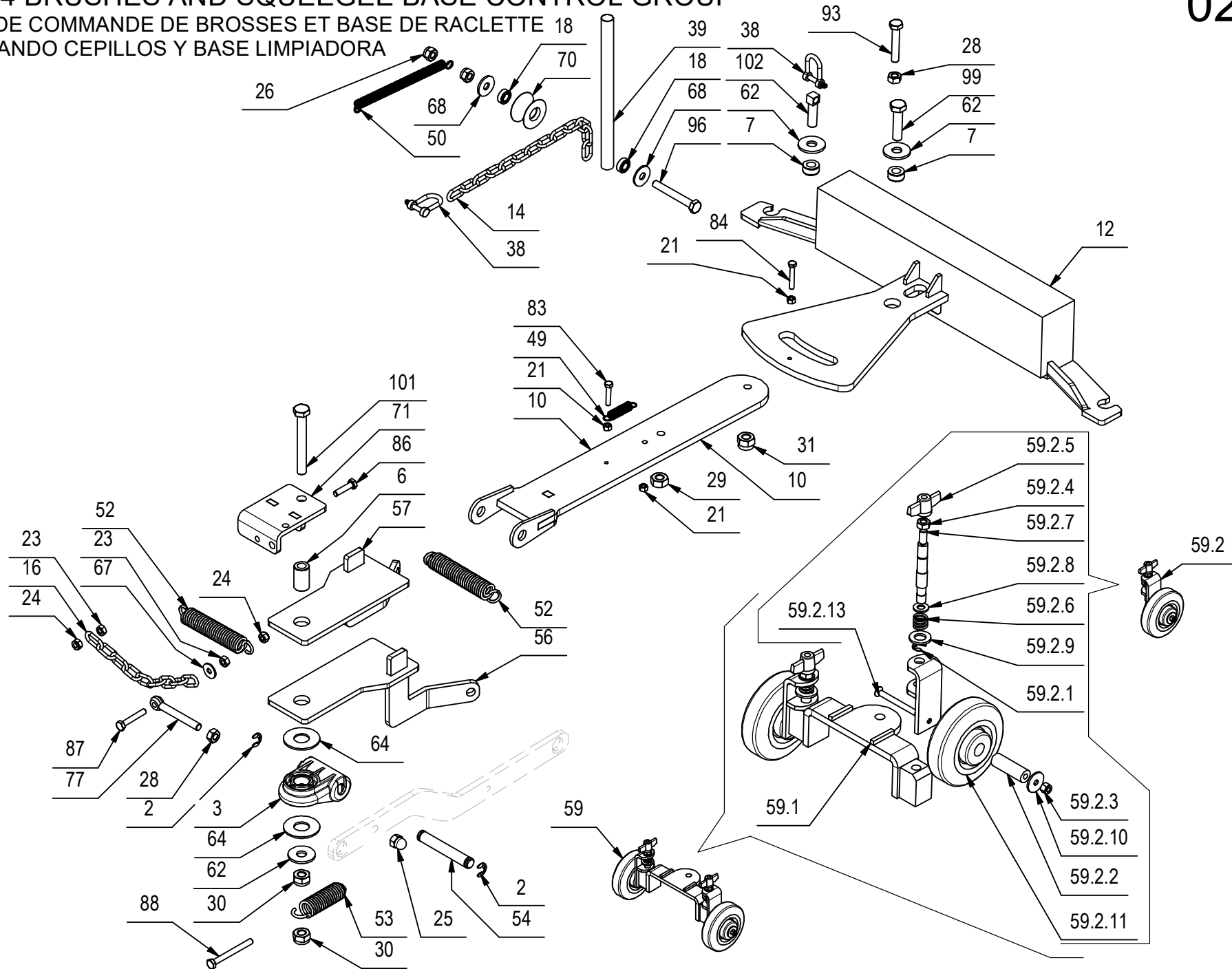



## CR-02/04 BRUSHES AND SQUEEGEE BASE CONTROL GROUP

02/04

-	POS	TECHNICAL NEWS	SERIAL NUMBER	CODICE	QTÀ	DESCRIZIONE	DESCRIPTION	DESIGNATION	DESCRIPCION
↑↑	59.2.5			410237	2	GALLETTO DI FISSAGGIO GB/48/FP M8	WING NUT	PAPILLON	POMO
↑↑	59.2.6			407625	2	MOLLA COMP. 16x2x13	SPRING	RESSORT	RESORTE
↑↑	59.2.7			400724	2	PERNO REGISTRO RUOTINA	PIN	AXE	PERNO
↑↑	59.2.8			409175	2	RONDELLA D17 UNI 6592 ZINC.	WASHER D17 UNI 6592 ZINC.	RONDELLE M8 UNI 6592 ZINC	ARANDELA M8 UNI 6592 ZINC
↑↑	59.2.9			409201	2	ROSETTA 13x24x2.5 UNI 6592 ZINC	WASHER	RONDELLE	ARANDELA
↑↑	59.2.10			409170	2	ROSETTA 6x24x2 UNI 6593 A2	WASHER	RONDELLE	ARANDELA
↑↑	59.2.11			405689	2	RUOTA DIAM 100x30 GRIGIA	WHEEL	ROUE	RUEDA
↑↑	59.2.12			203289	2	SUPPORTO RUOTA	SUPPORT	SUPPORT	SOPORTE
↑↑	59.2.13			415830	2	VITE M6X60 TPSEI UNI 5933 ZINC	SCREW	VIS	TORNILLO
	62			409194	14	RONDELLA 11x30x2,5 UNI 6593 ZINC	WASHER 11x30x2,5 UNI 6593 ZINC	RONDELLE	ARANDELA
	64			400639	2	RONDELLA D=40 d=17 S=2 DELRIN	SPECIAL WASHER	RONDELLE SPECIALE	ARANDELA ESPECIAL
	67			409160	3	RONDELLA D18 UNI 6593 ZINC	WASHER D18 UNI 6593 ZINC	RONDELLE	ARANDELA
	68			409179	11	RONDELLA D24 UNI 6593 ZINC	WASHER D24 UNI 6593 ZINC	RONDELLE M8 UNI 6593 ZINC	ARANDELA M8 UNI 6593 ZINC
	70			415242	3	RULLINO DIAM.35	ROLLER DIAM.35	ROULEAU	RODILLO
	71			219181	1	STAFFA MOLLA RIENTRO BASAMENTO MMG	SUPPORT	SUPPORT	SOPORTE
	77			410547	1	TIRANTE AD OCCHIO M8x65 UNI605 ZINC	TIE ROD	TIGE	TIRANTE
	83			407651	1	VITE M5X25 TE UNI 5739 DIN 933 (8.8)ZINC	SCREW	VIS	TORNILLO
	84			415716	1	VITE M5x30 TE UNI 5739 ZINC	SCREW	VIS	TORNILLO
	86			407669	2	VITE M6x25 TE UNI 5739 ZINC	SCREW	VIS	TORNILLO
	87			408651	2	VITE M6x35 TE UNI 5739 ZINC	SCREW	VIS	TORNILLO
	88			408658	1	VITE M6X60 TE UNI 5739 A2	SCREW	VIS	TORNILLO
	93			408681	1	VITE M8x45 TE UNI 5739 ZINC	SCREW	VIS	TORNILLO
	96			408693	1	VITE M8X60 TE UNI 5739 ZINC	SCREW	VIS	TORNILLO
	99			408715	4	VITE M10x40 TE UNI 5739 (8.8)	SCREW	VIS	TORNILLO
	101			430812	1	VITE M10X80 TE UNI5739 DIN933 (8.8) ZINC	SCREW	VIS	TORNILLO
	102			203412	1	VITE SUPPORTO REGISTRO M10 L=40	SPECIAL SCREW	VIS SPECIALE	TORNILLO REGULADOR

CR-03 SQUEEGEE ASSEMBLY L=38,94in

ENSEMBLE DE SUCEUR

GRUPO LIMPIADOR DE SUELO

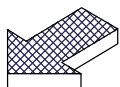
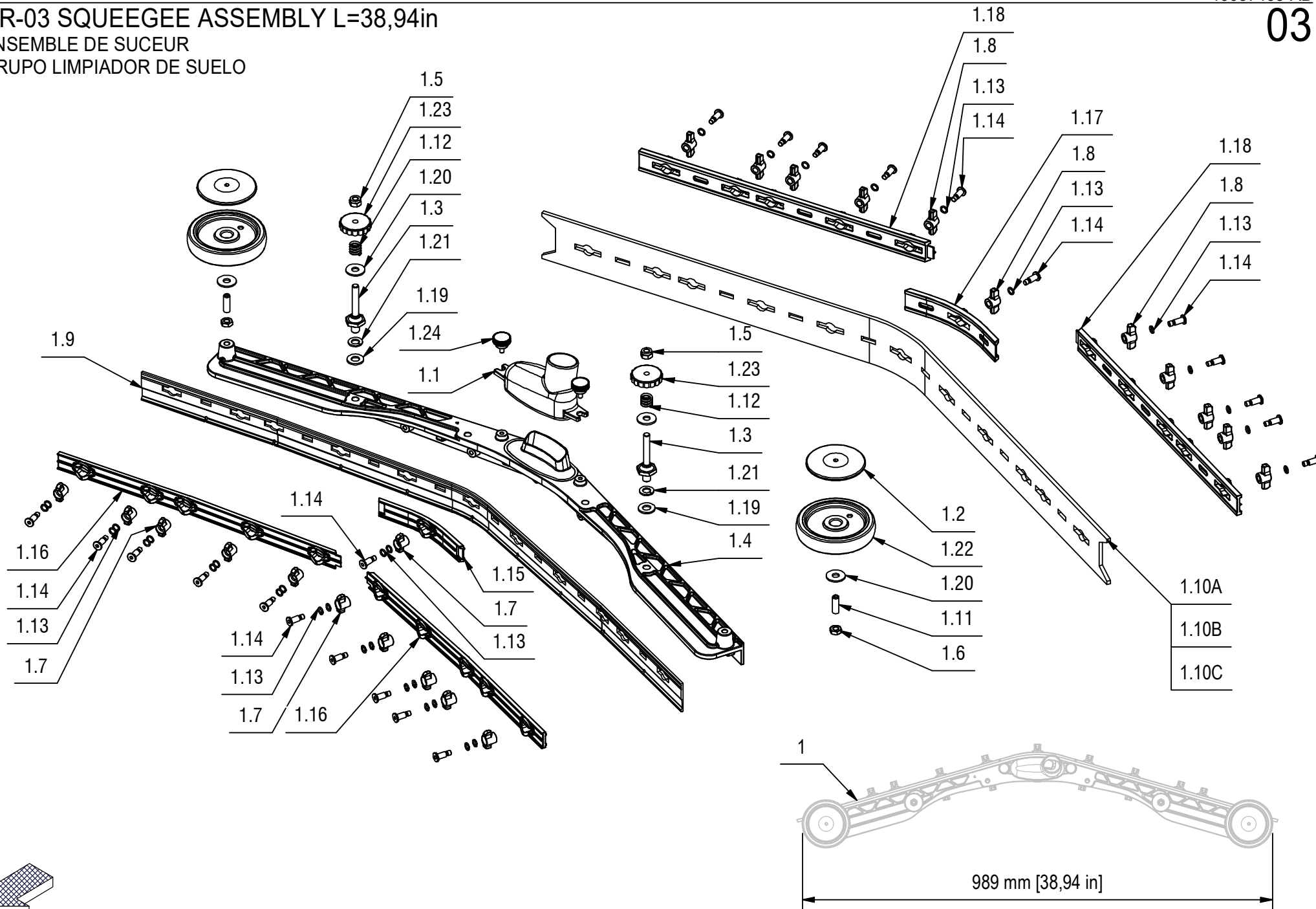

## CR-03 SQUEEGEE ASSEMBLY L=38,94in

03

-	POS	TECHNICAL NEWS	SERIAL NUMBER	CODICE	QTÀ	DESCRIZIONE	DESCRIPTION	DESIGNATION	DESCRIPCION
↓	1			222790	1	PREM. TERGIPAVIMENTO L=990	SQUEEGEE ASSEMBLY	SUCEUR COMPLETE	LIMPIAPAVIMENTOS COMPLETO
↑	1.1			430957	1	BOCCHETTA DRITTA D=40 + GUARN. TERGI2010	OPENING	BUSE	BOQUILLA
↑	1.2			436119	2	BOCCOLA COPERTURA RUOTINA BASAMENTO	BUMPER WHEEL COVER	COUVERCLE DE ROUE DE PARE-CHOCS	TAPA PARACHOQUES RUEDA
↑	1.3			219372	2	COLONNETTA SGANCIO M10-CH22 - M8 (28-45)	STUD BOLT	TIGE	PRISIONERO
↑	1.4			436780	1	CORPO TERGIPAVIMENTO 2010 L=926 ALL.	SQUEEGEE	CORPS DE SUCEUR	CUERPO LIMPIAPAVIMENTOS
↑	1.5			409087	2	DADO M8 UNI 7474 AISI	NUT M8 UNI 7474 AISI	ECROU AUTOFREINES	TUERCA AUTOBLOCANTE
↑	1.6			409048	2	DADO M8x5 UNI 5589 A2	NUT	ECROU	TUERCA
↑	1.7			430954	11	GALLETTO CHIUSURA ANTERIORE TERGI 2010	WING NUT	PAPILLON	POMO
↑	1.8			430955	11	GALLETTO CHIUSURA POSTERIORE TERGI 2010	WING NUT	PAPILLON	POMO
↑	1.9			219376	1	GOMMA ANTERIORE H=45 L=988 S=4 (PU)	FRONT RUBBER H=45 L=988 S=4 (PU)	BAVETTE AVANT H=45 L=988 S=4 (PU)	GOMA DELANTERA H=45 L=988 S=4 (PU)
↑	1.10A			431050	1	GOMMA POSTERIORE H=70 L=1048 S=5 (PU 33Sh)	REAR RUBBER H=70 L=1048 S=5 (PU 33Sh)	BAVETTE ARRIERE H=70 L=1048 S=5 (PU 33Sh)	GOMA TRASERA H=70 L=1048 S=5 (PU 33Sh)
	1.10B			430970	1	GOMMA POSTERIORE H=70 L=1048 S=5 (PU 40Sh)	REAR RUBBER H=70 L=1048 S=5 (PU 40Sh)	BAVETTE ARRIERE H=70 L=1048 S=5 (PU 40Sh)	GOMA TRASERA H=70 L=1048 S=5 (PU 40Sh)
	1.10C			431051	1	GOMMA POSTERIORE H=70 L=1048 S=5 (LATEX)	REAR RUBBER H=70 L=1048 S=5 (LATEX)	BAVETTE ARRIERE H=70 L=1048 S=5 (LATEX)	GOMA TRASERA H=70 L=1048 S=5 (LATEX)
↑	1.11			408913	2	GRANO M8x25 EI UNI 5923 A2	DOWEL	VIS CYLINDRIQUE	TORNILLO
↑	1.12			408098	2	MOLLA COMPR. 14,5x15x2,5 COLON. TERGIP.	SPRING	RESSORT	RESORTE
↑	1.13			431633	33	O-RING 7x1,5 NBR 70 SHORE	WASHER	RONDELLE	ARANDELA
↑	1.14			430903	22	PERNO MANOPOLINA D=11,8 d=7 M=6 H=22	PIN	AXE	PERNO
↑	1.15			430944	1	PREMIGOMMA ANTERIORE CENTRALE TERGI 2010	FRONT BLADE	PLAQUETTE AVANT	LISTON DELANTERA
↑	1.16			430947	2	PREMIGOMMA ANTERIORE L=926 TERGI 2010	FRONT BLADE	PLAQUETTE AVANT	LISTON DELANTERA
↑	1.17			430949	1	PREMIGOMMA POSTERIORE CENTRALE TERGI2010	REAR BLADE	PLAQUETTE ARRIERE	LISTON TRASERA
↑	1.18			430952	2	PREMIGOMMA POSTERIORE L=926 TERGI 2010	REAR BLADE	PLAQUETTE ARRIERE	LISTON TRASERA
↑	1.19			409192	2	RONDELLA D21 UNI 6592 AISI	WASHER D21 UNI 6592 AISI	RONDELLE	ARANDELA
↑	1.20			409185	4	RONDELLA D24 UNI 6593 AISI	WASHER D24 UNI 6593 AISI	RONDELLE	ARANDELA
↑	1.21			409200	2	ROSETTA GROWER 10x2,5x2,5 A2	LOCK WASHER	RONDELLE FREIN	ARANDELLA DENTADA
↑	1.22			436120	2	RUOTINA PARACOLPI BASAMENTO D=100 H=20	BUMPER WHEEL	BUTEE	PARACHOQUES
↑	1.23			400112	2	VOLANTINO LOBATO PASSANTE V/40/PS M8	HANDWHEEL	VOLANT	RUEDA DE MANIOBRA
↑	1.24			435330	2	VOLANTINO ZIGRINATO ZPX/22 M5x10 6331400	KNOB	POMMEAU	POMO



## CR-05 FRAME ASSEMBLY

05

-	POS	TECHNICAL NEWS	SERIAL NUMBER	CODICE	QTÀ	DESCRIZIONE	DESCRIPTION	DESIGNATION	DESCRIPCION
	1			218967	1	BARRA FILETTATA M5 L=102 ZINCATA	ROD	TIGE	VARILLA
	2			430441	2	BOCCOLA D=12-18 d=6,1 S=12,3 OT58	BUSHING	BAGUE	CASQUILLO
	3			411966	3	DADO DI PROLUNGAMENTO M6 CH10 H=18	NUT	ECROU	TUERCA
	4			409118	3	DADO M5 A GABBIA	CAGE NUT	ECROU EN CAGE	TUERCA
	5			409036	5	DADO M5x5 UNI 5587 ZINC	NUT M5x5 UNI 5587 ZINC	ECROU	TUERCA
	6			409080	3	DADO M5x7 AUTOBL. UNI 7473 ZINC	NYLOCK M5x7 UNI 7473 ZINC	ECROU AUTOFREINES	TUERCA AUTOBLOCANTE
	7			409082	11	DADO M6 UNI 7474 ZINC	NUT M6 UNI 7474 ZINC	ECROU AUTOFREINES	TUERCA AUTOBLOCANTE
	8			221170	1	DISTANZIALE D=CH8 d=M5 S=12 Fe360B	SPECIAL NUT	ECROU SPECIAL	TUERCA ESPECIAL
↓	9			216691	2	MICROINT. C/ROTEL STAGNO COMPLETO	MICROSWITCH	MICROINTERRUPTEUR	MICROINTERRUPTOR
↑	9.1			409951	1	COPRIFASTON MASCHIO 6,3	FASTON COVER	COUVERCLE DE FASTON	CUBREFASTON
↑	9.2			416138	2	COPRIFASTON X FEMMINA D.6.3 25X9 BIAN	FEMALE FASTON COVER	COUVERCLE DE FASTON	CUBREFASTON
↑	9.3			409890	2	FASTON FEMMINA 6,3 NUDO	FASTON FEMALE 6,3	FEMELLE FASTON	FASTON HEMBRA
↑	9.4			416087	1	FASTON MASCHIO NUDO D.6,3	FASTON	FASTON	FASTON
↑	9.5			427062	1	MICROINT. ABV1615613 C/ROTEL STAGNO	MICROSWITCH	MICROINTERRUPTEUR	MICROINTERRUPTOR
↑	9.6			221003	1	TUBETTO RESTRINGIBILE 9,5X240	SHEATH	GAINE	VAINA
	10			202480	2	MOLLA TRAZ. 10X1,1X46 ZINC	SPRING 10X1,1X46 ZINC	RESSORT	RESORTE
	11			221180	1	NASTRO ANTISCIVOLO PEDALE MARCIA INNOVA	TAPE	TAPE	CINTA
	12			219399	1	NASTRO ANTISCIVOLO PEDALE MARCIA MMG	TAPE	TAPE	CINTA
	13			218991	1	PEDALE ACCELERATORE AVANTI - RETRO MMG	PEDAL	PEDALE	PEDAL
	14			221159	1	PEDALE MARCIA AVANTI INNOVA 2011	PEDAL	PEDALE	PEDAL
	15			203279	1	PERNO A SFERA M5	PIN	AXE	PERNO
	16			219270	2	PIASTRINA SPESSORE CERNIERE MMG	PLAQUE	PLAQUETTE	PLAQUETA
↓	17			219271	1	PREM. COMANDO MARCIA MMG	POTENTIOMETER	POTENTIOMETRE	POTENCIOMETRO
↑	17.1			210183	1	BOCCOLA D=19-10 d=6 S=31,2 AVP	BUSHING	BAGUE	CASQUILLO
↑	17.2			400678	1	CAMMA DENTATA	CAM WHEEL	CAME	LEVA DENTADA
↑	17.3			409077	2	DADO M3x4,5 UNI 7474 ZINC	NUT M3x4,5 UNI 7474 ZINC	ECROU AUTOFREINES	TUERCA AUTOBLOCANTE
↑	17.4			409078	2	DADO M4x6 AUTOBL. UNI 7473 ZINC	LOCK NUT	ECROU AUTOFREINES	TUERCA AUTOBLOCANTE
↑	17.5			409081	1	DADO M5x7 UNI 7473 AISI	NUT M5x7 UNI 7473 AISI	ECROU AUTOBLOCANT	TUERCA AUTOBLOCANTE
↑	17.6			409082	1	DADO M6 UNI 7474 ZINC	NUT M6 UNI 7474 ZINC	ECROU AUTOFREINES	TUERCA AUTOBLOCANTE
↑	17.7			409491	2	MICROINT.10A 3X22 C/ROTEL 4.8 V5C010FB3D	LIMIT SWITCH 10A 3X22 4.8 V5C010F	MICROINTERRUPTEUR	MICROINTERRUPTOR
↑	17.8			407596	1	MOLLA POTENZIOMETRO G85-S888B	SPRING	RESSORT	RESORTE
↑	17.9			203279	1	PERNO A SFERA M5	PIN	AXE	PERNO
↑	17.10			400679	1	PIGNONE M=1 Z=20	PINION	PIGNON	PIÑON
↑	17.11			409249	1	POTENZIOMETRO ABJ 2,5 K	POTENTIOMETER	POTENTIOMETRE	POTENCIOMETRO
↑	17.12			409139	1	RONDELLA 3x8x1 UNI 6593 ZINC	WASHER 3x8x1 UNI 6593 ZINC	RONDELLE	ARANDELA
↑	17.13			409160	1	RONDELLA D18 UNI 6593 ZINC	WASHER D18 UNI 6593 ZINC	RONDELLE	ARANDELA

CR-05 FRAME ASSEMBLY

GRUPE CHASSIS  
GRUPO BASTIDOR

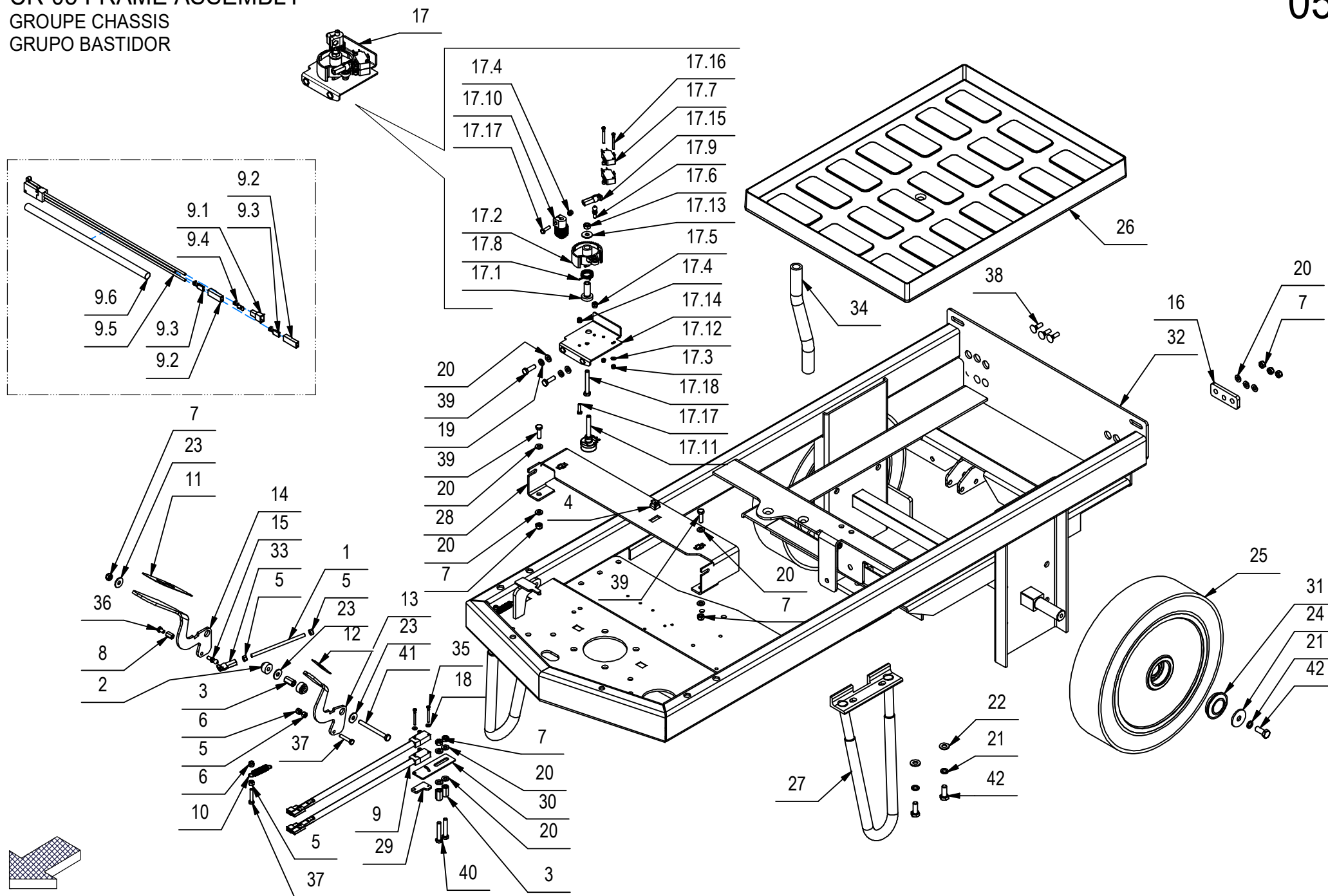

## CR-05 FRAME ASSEMBLY

05

-	POS	TECHNICAL NEWS	SERIAL NUMBER	CODICE	QTÀ	DESCRIZIONE	DESCRIPTION	DESIGNATION	DESCRIPCION
↑	17.14			218012	1	SUPP. POTENZIOMETRO MG 75-85-100	SUPPORT	SUPPORT	SOPORTE
↑	17.15			410316	1	TESTINA REGISTRABILE M5	ADJUSTABLE HEAD	TETE REGLABLE	CABEZA AJUSTABLE
↑	17.16			408836	2	VITE M3x30 TCTC UNI 7687 ZINC	SCREW	VIS	TORNILLO
↑	17.17			408639	2	VITE M4x16 TE UNI 5739 ZINC	SCREW	VIS	TORNILLO
↑	17.18			415723	1	VITE M6X45 TE UNI 5737 ZINC	SCREW	VIS	TORNILLO
	18			409139	2	RONDELLA 3x8x1 UNI 6593 ZINC	WASHER 3x8x1 UNI 6593 ZINC	RONDELLE	ARANDELA
	19			409164	2	RONDELLA D11,8 UNI 1751 ZINC	WASHER D11,8 UNI 1751 ZINC	RONDELLE FREIN	ARANDELLA DENTADA
	20			409156	16	RONDELLA D12 UNI 6592 ZINC	WASHER D12 UNI 6592 ZINC	RONDELLE	ARANDELA
	21			409181	6	RONDELLA D13 UNI 1751 ZINC	LOCK WASHER D13 UNI 1751 ZINC	RONDELLE FREIN	ARANDELLA DENTADA
	22			409175	4	RONDELLA D17 UNI 6592 ZINC.	WASHER D17 UNI 6592 ZINC.	RONDELLE M8 UNI 6592 ZINC	ARANDELA M8 UNI 6592 ZINC
	23			409160	3	RONDELLA D18 UNI 6593 ZINC	WASHER D18 UNI 6593 ZINC	RONDELLE	ARANDELA
	24			409180	2	ROSETTA 9x32x2.5 UNI 6593 ZINC	WASHER M8 D=32 UNI 6593 ZINC	RONDELLE M8 D=32 UNI 6593 ZINC	ARANDELA M8 D=32 UNI 6593 ZINC
	25			430836	2	RUOTA D=300 S=70	WHEEL	ROUE	RUEDA
	26			430990	1	SOTTOFONDO BATTERIE ABS DIM. 532x394	BATTERY BASE	BAC LOGEMENT BATTERIES	PLACA ASIENTO BATERIAS
	27			219786	2	STAFFA ANTIRIBALTAMENTO MMG	SUPPORT	ATTAQUE	SOPORTE FIJADOR
	28			219490	1	STAFFA SOSTEGNO PEDAMA MMG	SUPPORT	ATTAQUE	SOPORTE FIJADOR
	29			219111	1	STAFFETTA FERMA RELE' SOLLEV. MAN. MMG	SUPPORT	ATTAQUE	SOPORTE FIJADOR
	30			219117	1	STAFFETTA SUPPORTO MICRO PEDALE MMG	SUPPORT	SUPPORT	SOPORTE
	31			422390	2	TAPPO COPRIMOZZO G48 PER RUOTA GENIE	COVER	COUVERCLE	TAPA
	32			218885	1	TELAIO MMG	FRAME	CHASSIS	BASTIDOR
	33			410316	1	TESTINA REGISTRABILE M5	ADJUSTABLE HEAD	TETE REGLABLE	CABEZA AJUSTABLE
	34			209533	1	TUBO Di=13 De=20 L=220 PVC	PIPE	TUBE	TUBO
	35			408836	2	VITE M3x30 TCTC UNI 7687 ZINC	SCREW	VIS	TORNILLO
	36			407643	1	VITE M5X8 TE UNI 5739 ZINC	SCREW	VIS	TORNILLO
	37			407651	3	VITE M5X25 TE UNI 5739 DIN 933 (8.8)ZINC	SCREW	VIS	TORNILLO
	38			408620	6	VITE M6X20 UNI 5732 ZINC	SCREW M6X20 UNI 5732 ZINC	VIS	TORNILLO
	39			407666	4	VITE M6X20 UNI 5739 ZINC	SCREW M6X20 UNI 5739 ZINC	VIS	TORNILLO
	40			408651	2	VITE M6x35 TE UNI 5739 ZINC	SCREW	VIS	TORNILLO
	41			415722	1	VITE M6X65 TE UNI 5737 ZINC	SCREW	VIS	TORNILLO
	42			408670	6	VITE M8x20 UNI 5739 ZINC	SCREW M8x20 UNI 5739 ZINC	VIS	TORNILLO

# CR-06/08 BRAKE AND WHEELS ASSEMBLY

GRUPE DE FREIN ET ROUES  
GRUPO FRENO Y RUEDAS

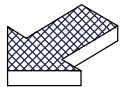
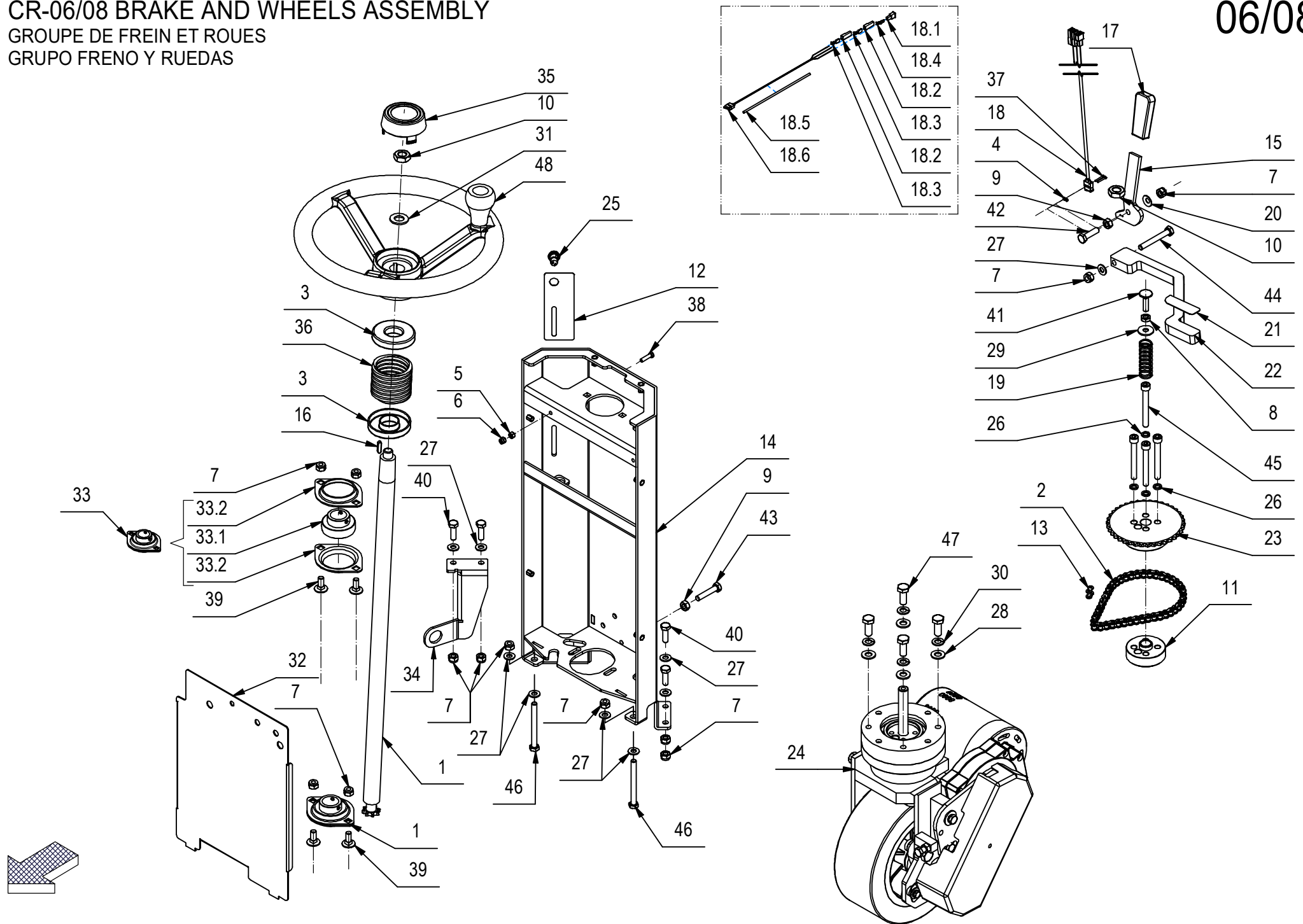



## CR-06/08 BRAKE AND WHEELS ASSEMBLY

06/08

-	POS	TECHNICAL NEWS	SERIAL NUMBER	CODICE	QTÀ	DESCRIZIONE	DESCRIPTION	DESIGNATION	DESCRIPCION
	1			212460	1	ALBERO STERZO ENJOY 365	SHAFT	ARBRE	EJE
	2			430881	1	CATENA 3/8"x7/32" 45 PASSI	CHAIN	CHAINE	CADENA
	3			429782	2	CENTRAGGIO SOFFIETTO MG	COLLAR	COLLIER	COLLAR
	4			435421	2	DADO M2 UNI 5588 INOX	NUT	ECROU	TUERCA
	5			409036	2	DADO M5x5 UNI 5587 ZINC	NUT M5x5 UNI 5587 ZINC	ECROU	TUERCA
	6			409080	2	DADO M5x7 AUTOBL. UNI 7473 ZINC	NYLOCK M5x7 UNI 7473 ZINC	ECROU AUTOFREINES	TUERCA AUTOBLOCANTE
	7			409085	12	DADO M8 UNI 7474 - ZINC	NUT M8 UNI 7474 - ZINC	ECROU AUTOFREINES M8 UNI 7474 - ZINC	TUERCA AUTOBLOCANTE M8 UNI 7474 - ZINC
	8			409054	1	DADO M8x5 UNI 5589 ZINC	NUT M8x5 UNI 5589 ZINC	ECROU	TUERCA
	9			409046	2	DADO M8x6,5 UNI 5588 ZINC	NUT M8x6,5 UNI 5588 ZINC	ECROU	TUERCA
	10			415895	1	DADO M14X2 UNI 5589 ZINC.	SCREW M14X2 UNI 5589 ZINC.	VIS	TORNILLO
	11			219051	1	DISTANZIALE MOZZO RUOTA TRAZ. Ø60x16	SPACER	ENTRETOISE	DISTANCIADOR
	12			431085	1	ETICHETTA RUBINETTO ACQUA MMG-MR	DECAL	ETIQUETTE	ETIQUETA
	13			411947	1	GIUNTO CATENA DA 3/8	JOINT CHAIN	ATTACHE RAPIDE CHAINE	ACOPLAMIENTO CADENA
	14			218954	1	LAMIERA PIANTONE STERZO MMG	STEERING COLUMN	COLONNE DE DIRECTION	COLUMNNA DE DIRECCION
	15			218990	1	LEVA FRENO DI STAZIONAMENTO MMG	LEVER	LEVIER	PALANCA
	16			408402	1	LINGUETTA 5X5X20 UNI 6604/69	FLAT KEY 5X5X20 UNI 6604/69	CLAVETTE	CLAVIJA
	17			410251	1	MANOPOLA PVC 70x30	KNOB PVC 70x30	POIGNEE	EMPUÑADURA
	↓ 18			222013	1	MICROINTERR. STAGNO ABJ 2612609 CABLATO	MICROSWITCH	MICROINTERRUPTEUR	MICROINTERRUPTOR
	↑ 18.1			409951	1	COPRIFASTON MASCHIO 6,3	FASTON COVER	COUVERCLE DE FASTON	CUBREFASTON
	↑ 18.2			416138	2	COPRIFASTON X FEMMINA D.6.3 25X9 BIAN	FEMALE FASTON COVER	COUVERCLE DE FASTON	CUBREFASTON
	↑ 18.3			409890	2	FASTON FEMMINA 6,3 NUDO	FASTON FEMALE 6,3	FEMELLE FASTON	FASTON HEMBRA
	↑ 18.4			416087	1	FASTON MASCHIO NUDO D.6,3	FASTON	FASTON	FASTON
	↑ 18.5			222008	1	GUAINA TERMORESTRINGENTE D.3,2 L=200	SHEATH	GAINE	VAINA
	↑ 18.6			435425	1	MICROINTERRUPTORE STAGNO ABJ 2612609	MICROSWITCH	MICROINTERRUPTEUR	MICROINTERRUPTOR
	19			215490	1	MOLLA A COMPRESSIONE D 20X2X60	SPRING	RESSORT	RESORTE
	20			409178	1	MOLLA A TAZZA 8x18x1	CUPPED WASHER	RONDELLE CONCAVE	ARANDELA CONCAVA
	21			219400	1	NASTRO ANTISCIVOLO PEDALE FRENO MMG	TAPE	TAPE	CINTA
	22			219056	1	PEDALE COMANDO FRENO MMG	BRAKE PEDAL	PEDALE DE FREIN	PEDAL MANDO FRENO
	23			219050	1	PIGNONE 3-8x7-32 z=38	PINION	PIGNON	PIÑON
	24			219322	1	PREM. RUOTA TRAZIONE MMG	WHEEL	ROUE	RUEDA
	25			428667	1	PULSANTE NERO NO 100mA 50V DC	PUSH BUTTON	BOUTON POUSSOIR	PULSADOR
	26			409181	4	RONDELLA D13 UNI 1751 ZINC	LOCK WASHER D13 UNI 1751 ZINC	RONDELLE FREIN	ARANDELLA DENTADA
	27			409175	9	RONDELLA D17 UNI 6592 ZINC.	WASHER D17 UNI 6592 ZINC.	RONDELLE M8 UNI 6592 ZINC	ARANDELA M8 UNI 6592 ZINC
	28			409191	4	RONDELLA D21 UNI 6592 ZINC	WASHER D21 UNI 6592 ZINC	RONDELLE	ARANDELA
	29			409179	1	RONDELLA D24 UNI 6593 ZINC	WASHER D24 UNI 6593 ZINC	RONDELLE M8 UNI 6593 ZINC	ARANDELA M8 UNI 6593 ZINC
	30			409196	4	ROSETTA GROWER 10x18x2,2 ZINC	LOCK WASHER	RONDELLE FREIN	ARANDELLA DENTADA

# CR-06/08 BRAKE AND WHEELS ASSEMBLY

GRUPE DE FREIN ET ROUES  
GRUPO FRENO Y RUEDAS

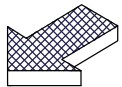
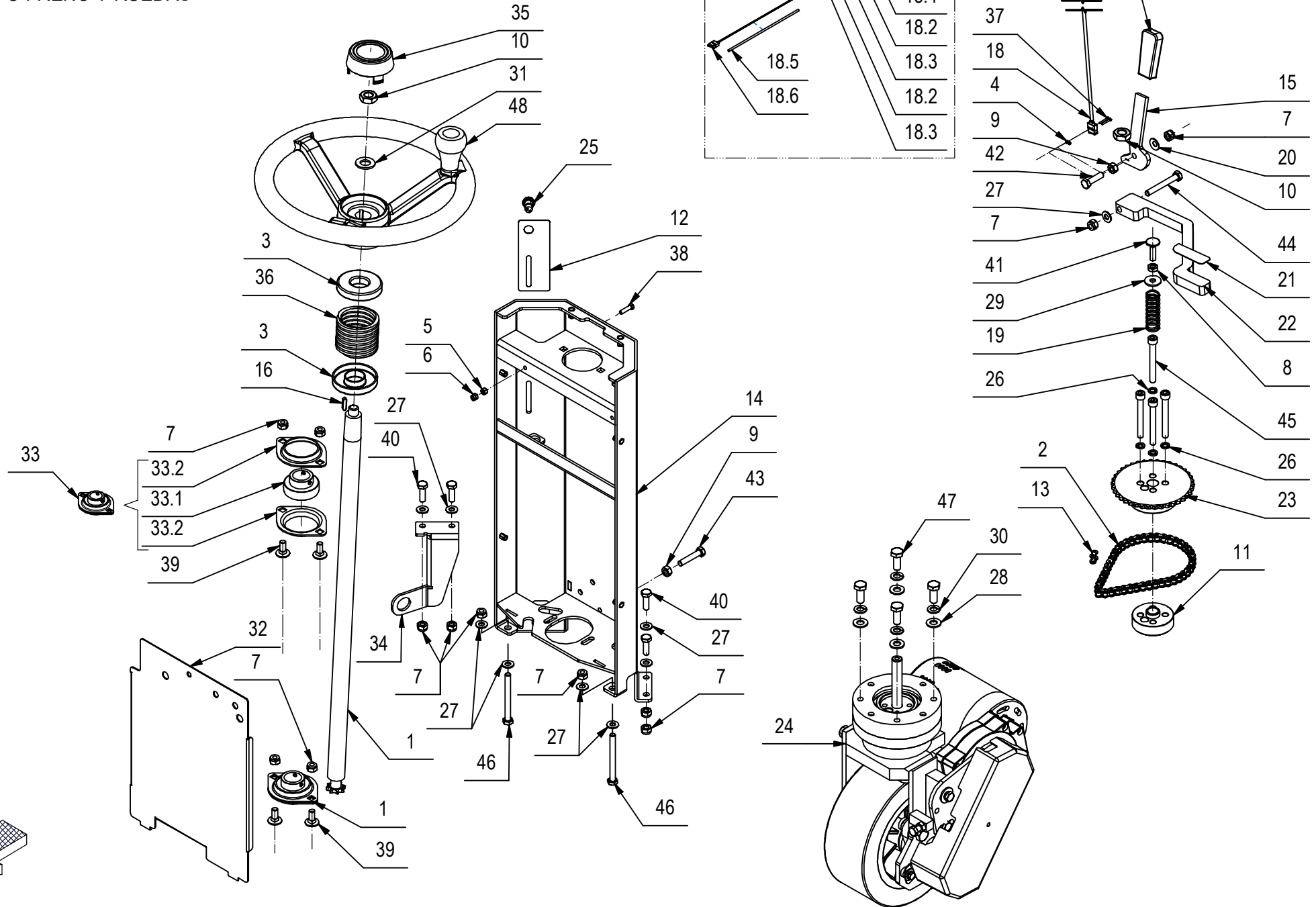

## CR-06/08 BRAKE AND WHEELS ASSEMBLY

06/08

-	POS	TECHNICAL NEWS	SERIAL NUMBER	CODICE	QTÀ	DESCRIZIONE	DESCRIPTION	DESIGNATION	DESCRIPCION
	31			409211	1	ROSETTA M15 UNI 6592 ZINC	WASHER	RONDELLE	ARANDELA
	32			219119	1	STAFFA COPERTURA INT. PIANTONE MMG	SUPPORT	SUPPORT	SOPORTE
↓	33			204351	2	SUPPORTO BPFL 205	SUPPORT	SUPPORT	SOPORTE
↑	33.1			415661	1	CUSCINETTO SB 205 CON BLOCC	BEARING	ROULEMENT	COJINETE
↑	33.2			415660	2	FLANGIA BPFL 205 PER SUPP.	FLANGE	FLASQUE	BRIDA
	34			218992	1	SUPPORTO GRUPPO FILTRO MMG	SUPPORT	SUPPORT	SOPORTE
	35			425416	1	TAPPO PER VOLANTE 320	PLUG	BOUCHON	TAPON
	36			219552	1	TUBO FLEX SOFF.STERZO MMG L=50 (NERO)	BELLOWS	SOUFFLET	FUELLE
	37			435420	2	VITE M2X16 TCCI UNI 6107 INOX	SCREW	VIS	TORNILLO
	38			407647	2	VITE M5x20 TE UNI 5739 ZINC	SCREW M5X20 UNI 5739 ZINC	VIS M5X20 UNI 5739 ZINC	TORNILLO M5X20 UNI 5739 ZINC
	39			408626	4	VITE M8x20 TTQST UNI 5732 ZINC	SCREW	VIS	TORNILLO
	40			408674	4	VITE M8x25 UNI 5739 ZINC	SCREW M8x25 UNI 5739 ZINC	VIS	TORNILLO
	41			412133	1	VITE M8x30 TTQST UNI 5732 ZINC	SCREW	VIS	TORNILLO
	42			408676	1	VITE M8X30 UNI 5739 ZINC	SCREW M8X30 UNI 5739 ZINC	VIS M8X30 UNI 5739 ZINC	TORNILLO M8X30 UNI 5739 ZINC
	43			408679	1	VITE M8x40 UNI 5739 ZINC	SCREW M8x40 UNI 5739 ZINC	VIS	TORNILLO
	44			408693	1	VITE M8X60 TE UNI 5739 ZINC	SCREW	VIS	TORNILLO
	45			418302	4	VITE M8x70 TCEI UNI 5931 FP ZINC	SCREW	VIS	TORNILLO
	46			408687	2	VITE M8X80 TE UNI 5737 FP ZINC	SCREW	VIS	TORNILLO
	47			408711	4	VITE M10X25 TE UNI 5739 ZINC	SCREW	VIS	TORNILLO
	48			425415	1	VOLANTE 320X107 C/P	STEERING WHEEL	VOLANT DE DIRECTION	VOLANTE

CR-07 TRACTION ASSEMBLY 24V 400W 240G

GRUPE DE TRACTION  
GRUPO TRACCION

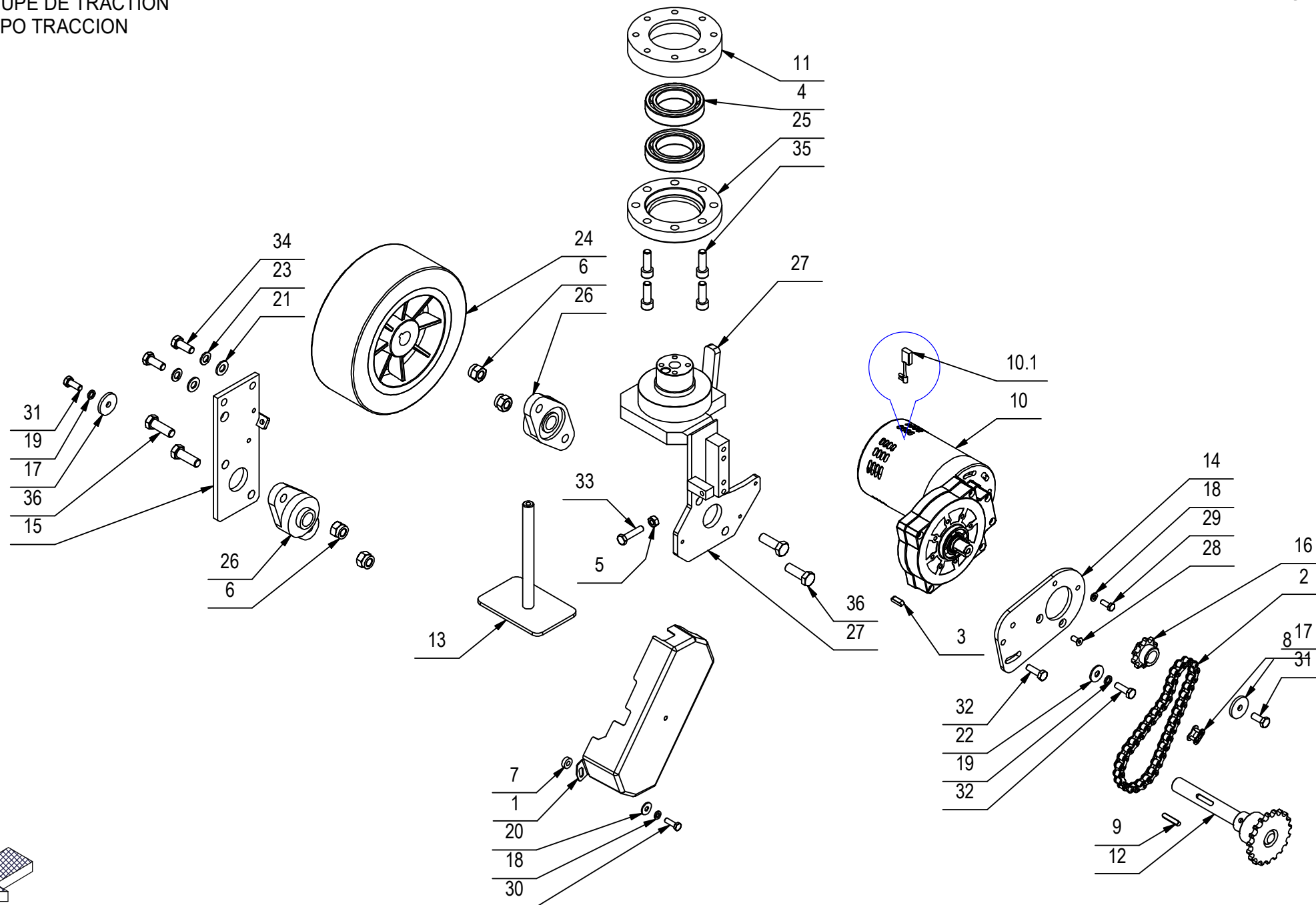

## CR-07 TRACTION ASSEMBLY 24V 400W 240G

-	POS	TECHNICAL NEWS	SERIAL NUMBER	CODICE	QTÀ	DESCRIZIONE	DESCRIPTION	DESIGNATION	DESCRIPCION
	1			415497	1	CARTER RUOTA TRAZIONE DUSTER M	COVER	CARTER	CARTER
	2			420861	1	CATENA 1-2x5-16 Z=35	CHAIN	CHAINE	CADENA
	3			408410	1	CHIAVETTA 6x6x20 UNI 6604/A	KEY	CLAVETTE	CLAVIJA
	4			408450	2	CUSCINETTO 6010 2RS 50x80x16	BEARING	ROULEMENT	COJINETE
	5			409046	1	DADO M8x6,5 UNI 5588 ZINC	NUT M8x6,5 UNI 5588 ZINC	ECROU	TUERCA
	6			409093	4	DADO M12x14 AUTOBL. UNI 7473 ZINC	NUT	ECROU	TUERCA
	7			411760	3	DISTANZIALE D=15 d=6,5 S=5 PVC	SPACER	ENTRETOISE	DISTANCIADOR
	8			408380	1	GIUNTO CATENA DA 1/2	JOINT CHAIN	ATTACHE RAPIDE CHAINE	ACOPLAMIENTO CADENA
	9			408412	1	LINGUETTA 6X6X30 UNI 6604/A	KEY	CLAVETTE	CLAVIJA
↓	10			212394	1	MOTORID. 24V 400W 240G IP20 MRP6	GEARED MOTOR	MOTO-REDUCTEUR	MOTORREDUCTOR
↑	10.1			422462	4	SPAZZ. MOT. 7X14X19 VISPA-GENIE (FASTON)	CARBON BRUSH MOTOR	CHARBON MOTEUR	ESCOBILLA MOTOR
	11			212552	1	MOZZO PIANTONE	HUB	MOYEU	CUBO
	12			212381	1	PERNO RUOTA TRAZIONE Z=19 DIN 8187	PIN	AXE	PERNO
	13			218968	1	PIASTRA FRENO MMG	BRAKE PLATE	PLAQUE DE FREIN	PLATO DE FRENO
	14			212972	1	PIASTRA MOTORE	PLAQUE	PLAQUE	PLACA
	15			204296	1	PIASTRA SUPPORTO RUOTA	PLAQUE	PLAQUE	PLACA
	16			414749	1	PIGNONE 1/2"x5/16" Z=10	PINION	PIGNON	PIÑON
	17			400167	2	RONDELLA 8,2x32x4	WASHER	RONDELLE	ARANDELA
	18			409164	5	RONDELLA D11,8 UNI 1751 ZINC	WASHER D11,8 UNI 1751 ZINC	RONDELLE FREIN	ARANDELLA DENTADA
	19			409181	2	RONDELLA D13 UNI 1751 ZINC	LOCK WASHER D13 UNI 1751 ZINC	RONDELLE FREIN	ARANDELLA DENTADA
	20			409160	3	RONDELLA D18 UNI 6593 ZINC	WASHER D18 UNI 6593 ZINC	RONDELLE	ARANDELA
	21			409191	2	RONDELLA D21 UNI 6592 ZINC	WASHER D21 UNI 6592 ZINC	RONDELLE	ARANDELA
	22			409179	1	RONDELLA D24 UNI 6593 ZINC	WASHER D24 UNI 6593 ZINC	RONDELLE M8 UNI 6593 ZINC	ARANDELA M8 UNI 6593 ZINC
	23			409196	2	ROSETTA GROWER 10x18x2,2 ZINC	LOCK WASHER	RONDELLE FREIN	ARANDELLA DENTADA
	24			430857	1	RUOTA D=220 S=80	POLYURETHANE WHEEL	ROUE POLYURETHANE	RUEDA DE POLIURETANO
	25			203981	1	SUPPORTO CUSCINETTO	SUPPORT	SUPPORT	SOPORTE
	26			415675	2	SUPPORTO CUSCINETTO UCFL 204 N	BEARING SUPPORT	SUPPORT ROULEMENT	SOPORTE COJINETE
	27			219320	1	SUPPORTO RUOTA TRAZIONE MMG	SUPPORT WHEELS	SUPPORT ROUES	SOPORTE RUEDAS
	28			415822	2	VITE M6X14 TSPCE UNI 5933 10.9 ZINC	SCREW	VIS	TORNILLO
	29			407663	2	VITE M6x16 TE UNI 5739 ZINC	SCREW	VIS	TORNILLO
	30			407666	3	VITE M6X20 UNI 5739 ZINC	SCREW M6X20 UNI 5739 ZINC	VIS	TORNILLO
	31			408670	2	VITE M8x20 UNI 5739 ZINC	SCREW M8x20 UNI 5739 ZINC	VIS	TORNILLO
	32			408674	2	VITE M8x25 UNI 5739 ZINC	SCREW M8x25 UNI 5739 ZINC	VIS	TORNILLO
	33			408678	1	VITE M8X35 TE UNI 5739 ZINC	SCREW	VIS	TORNILLO
	34			408711	2	VITE M10X25 TE UNI 5739 ZINC	SCREW	VIS	TORNILLO
	35			408824	4	VITE M10x30 TCEI UNI 5931 ZINC	SCREW	VIS	TORNILLO
	36			408746	4	VITE M12X35 TE UNI 5739 ZINC	SCREW	VIS	TORNILLO

CR-09/10 TANK GROUP AND ACCESSORIES (VER. RAL 7016 - RAL 7016)

GRUPE DE RÉSERVOIRS ET ACCESSOIRES (VER. RAL 7016 - RAL 7016)

GRUPO DE DEPÓSITO Y ACCESORIOS (VER. RAL 7016 - RAL 7016)

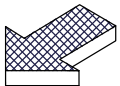
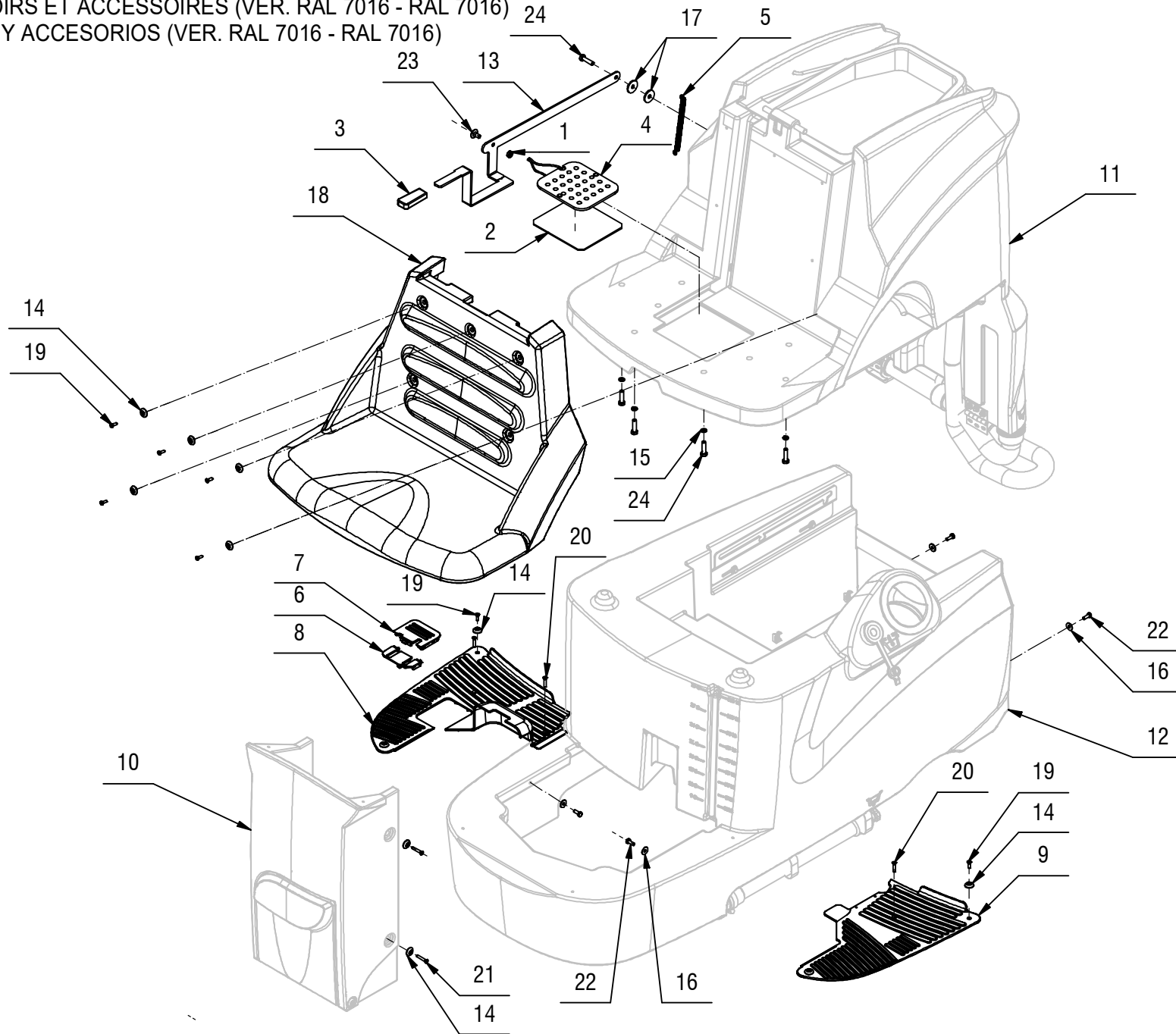

## CR-09/10 TANK GROUP AND ACCESSORIES (VER. RAL 7016 - RAL 7016)

09/10

-	POS	TECHNICAL NEWS	SERIAL NUMBER	CODICE	QTÀ	DESCRIZIONE	DESCRIPTION	DESIGNATION	DESCRIPCION
	1			409054	1	DADO M8x5 UNI 5589 ZINC	NUT M8x5 UNI 5589 ZINC	ECROU	TUERCA
	2			434201	1	GOMMA LUBRITENE 160 x 140 SP=3	RUBBER	BAVETTE	GOMA
	3			410251	1	MANOPOLA PVC 70x30	KNOB PVC 70x30	POIGNEE	EMPUÑADURA
	4			409503	1	MICROINT. PER SEDILE	MICROSWITCH	MICROINTERRUPTEUR	MICROINTERRUPTOR
	5			408123	1	MOLLA TRAZ. 10x1x103	SPRING	RESSORT	RESORTE
	6			431283	1	PEDANA COPRI PEDALE ANTERIORE MMG	BOTTOM PLATE	REPOSE PIED	PLATAFORMA
	7			431282	1	PEDANA COPRI PEDALE POSTERIORE MMG	BOTTOM PLATE	REPOSE PIED	PLATAFORMA
	8			431280	1	PEDANA DESTRA MMG	BOTTOM PLATE	REPOSE PIED	PLATAFORMA
	9			431281	1	PEDANA SINISTRA MMG	BOTTOM PLATE	REPOSE PIED	PLATAFORMA
	10			222951	1	PREM. MUSETTO MR 2013	INSTRUMENT BOARD ASSEMBLY	GROUPE TABLEAU DE BORD	GRUPO TABLERO DE INSTRUMENTOS
	11			219368	1	PREM. SERBATOIO RECUPERO MMG	RECOVERY TANK ASSEMBLY	GROUPE DE RESERVOIRE EAU SALE	GRUPO TANQUE AGUA SUCIA
	12			219367	1	PREM. SERBATOIO SOLUZIONE MMG 2013	SOLUTION TANK	RESERVOIR EAU PROPRE	TANQUE SOLUCION
	13			221852	1	PUNTELLO SALDATO SERBATOIO RECUPERO MMG	PROP	LEVIER	PUNTAL
	14			400250	13	RONDELLA D=5X20	SPECIAL WASHER D=5X20	RONDELLE SPECIALE	ARANDELA ESPECIAL
	15			409181	4	RONDELLA D13 UNI 1751 ZINC	LOCK WASHER D13 UNI 1751 ZINC	RONDELLE FREIN	ARANDELA DENTADA
	16			409160	4	RONDELLA D18 UNI 6593 ZINC	WASHER D18 UNI 6593 ZINC	RONDELLE	ARANDELA
	17			409182	2	ROSETTA 8,5x30x3 NYLON	WASHER	RONDELLE	ARANDELA
	18			430934	1	SEDILE MMG	SEAT	SIEGE	ASIENTO
	19			408516	9	VITE M5x16 TSCTC UNI 7689 ZINC	SCREW	VIS	TORNILLO
	20			415802	3	VITE M5x25 TSPTC UNI 7688 ZINC	SCREW	VIS	TORNILLO
	21			435407	4	VITE M5X30 TSCTC DIN 966 ZINCATA	SCREW	VIS	TORNILLO
	22			407663	4	VITE M6x16 TE UNI 5739 ZINC	SCREW	VIS	TORNILLO
	23			408625	1	VITE M8x16 TTQST UNI 5732 DIN 603	SCREW	VIS	TORNILLO
	24			408676	5	VITE M8X30 UNI 5739 ZINC	SCREW M8X30 UNI 5739 ZINC	VIS M8X30 UNI 5739 ZINC	TORNILLO M8X30 UNI 5739 ZINC

# CR-09/10A INSTRUMENT BOARD ASSEMBLY

GROUPE TABLEAU DE BORD  
GRUPO TABLERO DE INSTRUMENTOS

# 09/10 A

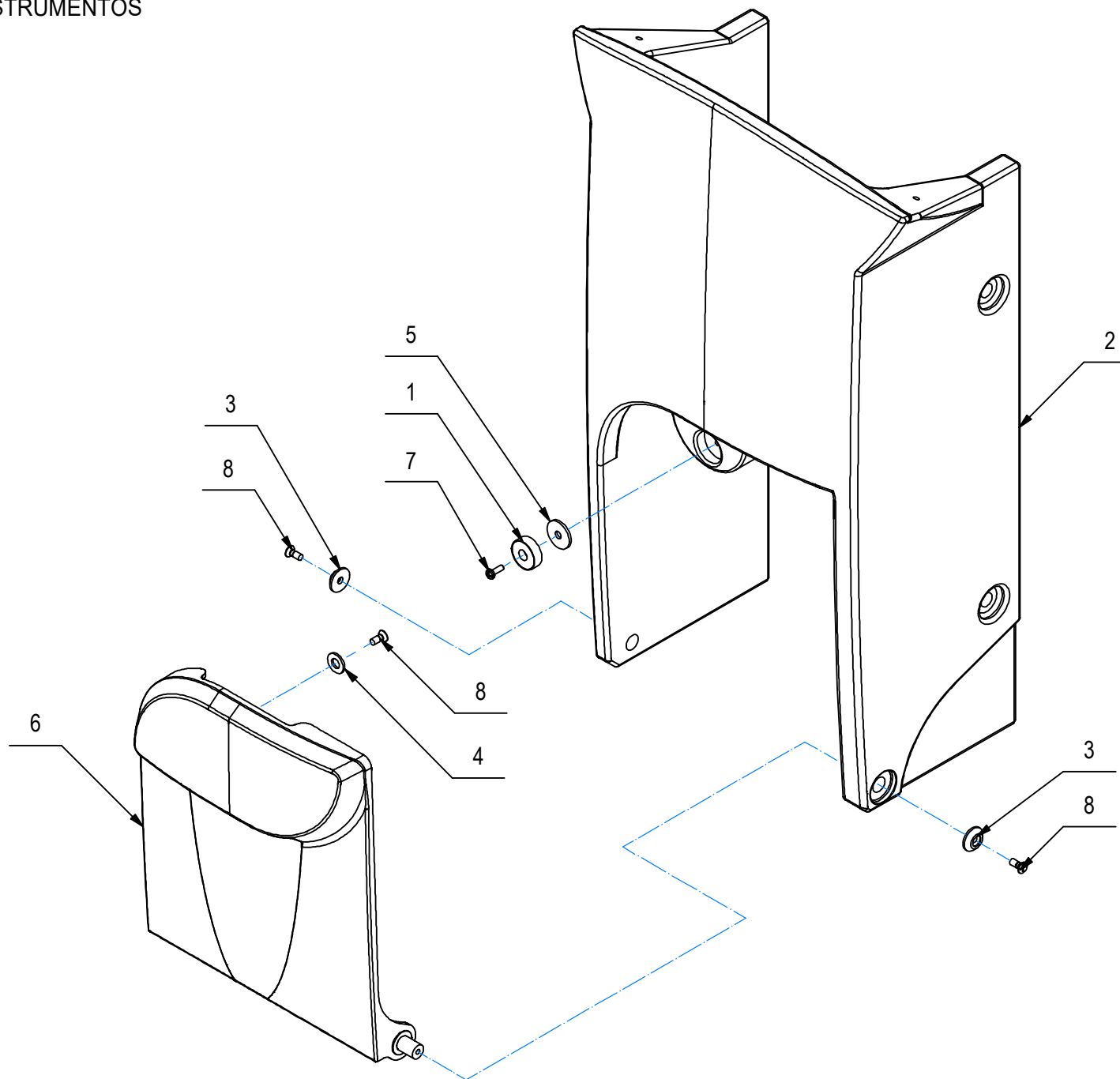



## CR-09/10A INSTRUMENT BOARD ASSEMBLY

09/10 A

-	POS	TECHNICAL NEWS	SERIAL NUMBER	CODICE	QTÀ	DESCRIZIONE	DESCRIPTION	DESIGNATION	DESCRIPCION
	1			427113	1	MAGNETE Ø25 x Ø5 x 8 - 17 kg (SM09.2585)	MAGNET	AIMANT	IMAN
	2			437389	1	MUSETTO ROTAZIONALE MMG GRIGIO ICO 727	INSTRUMENT BOARD	TABLEAU DE BORD	TABLERO DE INSTRUMENTOS
	3			400250	2	RONDELLA D=5X20	SPECIAL WASHER D=5X20	RONDELLE SPECIALE	ARANDELA ESPECIAL
	4			409175	1	RONDELLA D17 UNI 6592 ZINC.	WASHER D17 UNI 6592 ZINC.	RONDELLE M8 UNI 6592 ZINC	ARANDELA M8 UNI 6592 ZINC
	5			409162	1	ROSETTA 6,5x24x2 UNI 6593 ZINC	WASHER 6,5x24x2 UNI 6593 ZINC	RONDELLE	ARANDELA
	6			430919	1	SPORTELLO VANO DETERGENTE RAL 7016	DOOR	PORTILLON	PORTEZUELA
	7			415778	1	VITE M4X12 TCTC UNI 7687 INOX A2	SCREW	VIS	TORNILLO
	8			415750	3	VITE M5X12 TSPTC UNI 7688 (4.8) ZINC.	SCREW	VIS	TORNILLO

CR-09 PRE-ASSEMBLY OF SOLUTION TANK (VER. RAL 7016)

PRÉ-ASSEMBLAGE DU RÉSERVOIR DE SOLUTION (VER. RAL 7016)

PREMONTAJE DEPÓSITO DE SOLUCIÓN (VER. RAL 7016)

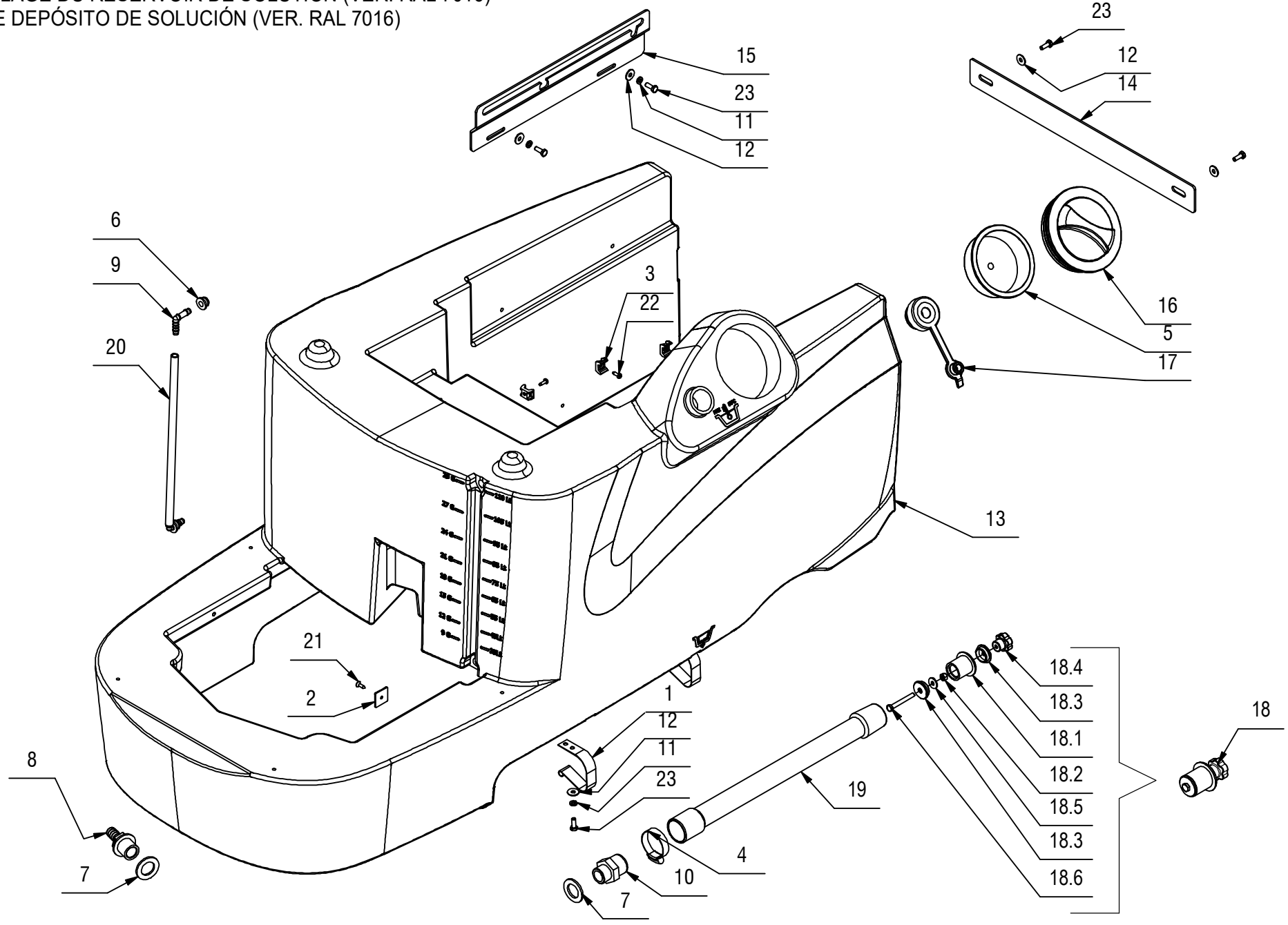

## CR-09 PRE-ASSEMBLY OF SOLUTION TANK (VER. RAL 7016)

09

-	POS	TECHNICAL NEWS	SERIAL NUMBER	CODICE	QTÀ	DESCRIZIONE	DESCRIPTION	DESIGNATION	DESCRIPCIÓN
	1			203595	2	AGGANCIO TUBO SCARICO	COUPLER	ACCROCHAGE	ENGANCHE
	2			410327	1	BASSETTA ADES. FISSA FASCETTE ABM 25-A-C	SUPPORT PLATE	PLAQUE SUPPORT	PLACA SOPORTE
	3			409819	4	BASSETTA TC 142 PER FASCETTE	SUPPORT TC 142	PLAQUE SUPPORT	PLACA SOPORTE
	4			410290	1	FASCETTA A VITE 32-44x12,2	CLAMP	COLLIER	ABRAZADERA
	5			405416	1	FILTRO A TAZZA De118 Di108 H40	FILTER	FILTRE	FILTRO
	6			428561	2	GUARNIZIONE D=20 d=8 L=12,5 TIPO PWS8	GASKET	JOINT	JUNTA
	7			405919	2	GUARNIZIONE D=40 d=26 S=3 LUBRITENE	GASKET	JOINT	JUNTA
	8			410374	1	PORTAGOMMA DIRITTO 3/4" M D16	CONNECTOR	RACCORD	EMPALME TUBO DE GOMA
	9			428562	2	RACCORDO A GOMITO D=8 L=30 TIPO WS8	ELBOW	COUDE	RACOR CODO
	10			431535	1	RACCORDO MASCHIO d=25 x D=32 x 3/4" PVC	FITTING	RACCORD	RACOR
	11			409164	4	RONDELLA D11,8 UNI 1751 ZINC	WASHER D11,8 UNI 1751 ZINC	RONDELLE FREIN	ARANDELLA DENTADA
	12			409160	6	RONDELLA D18 UNI 6593 ZINC	WASHER D18 UNI 6593 ZINC	RONDELLE	ARANDELA
	13			437385	1	SERBATOIO SOLUZIONE MMG GRIGIO ICO 727	SOLUTION TANK	RESERVOIR EAU PROPRE	TANQUE SOLUCION
	14			219345	1	STAFFA CHIUSURA POST. SERB. SOLUZ. MMG	SUPPORT	ATTAQUE	SOPORTE FIJADOR
	15			219347	1	STAFFA PUNTELLO SERBATOIO MMG	SUPPORT	ATTAQUE	SOPORTE FIJADOR
	16			400728	1	TAPPO FILETT. D.130 FIL. D.127 PER E9719	THREADED COVER	COUVERCLE FILETE	TAPA FILETE
	17			426342	1	TAPPO RIEMPIMENTO RAPIDO SOLUZIONE MX	CAP	CAPUCHON	TAPON
	↓ 18			204356	1	TAPPO SCARICO D=30 SENZA FASCETTA	PLUG EXHAUST PIPE	BOUCHON DE VIDANGE	TAPON DE DESCARGA
	↑ 18.1			400158	1	CORPO TAPPO SCARICO	BODY	CORPS	CUERPO
	↑ 18.2			409041	1	DADO M6x6 UNI 5587 A2	NUT	ECROU	TUERCA
	↑ 18.3			400157	2	FONDO TAPPO SCARICO	FLANGE FILTERHOLDER	FLASQUE	BRIDA
	↑ 18.4			410223	1	POMELLO D.30 M6 F.P.	KNOB	POMMEAU	POMO
	↑ 18.5			409161	1	RONDELLA D18x2 UNI 6593 AISI	WASHER D18x2 UNI 6593 AISI	RONDELLE	ARANDELA
	↑ 18.6			408657	1	VITE M6X50 UNI 5739 AISI	SCREW M6X50 UNI 5739 AISI	VIS	TORNILLO
	19			213150	1	TUBO SCARICO (SVILUPPO)	EXHAUST PIPE	FLEXIBLE DE VIDANGE	TUBO DE DESCARGA
	20			219366	1	TUBO VITREO D=12 d=8 L=320	PIPE	TUBE	TUBO
	21			408954	1	VITE D.4,2X16 TPSTC ZINC	LOCK SCREW 4.2X16	VIS AUTOBLOQUANT 4.2X16	TORNILLO AUTOBLOCANTE 4.2X16
	22			408880	4	VITE D.4.2x13 AUTOF.UNI 10227 X PLASTICA	SCREW	VIS	TORNILLO
	23			407663	6	VITE M6x16 TE UNI 5739 ZINC	SCREW	VIS	TORNILLO

CR-10 PRE-ASSEMBLY OF RECOVERY TANK (VER. RAL 7016)

PRÉ-ASSEMBLAGE DU RÉSERVOIR DE RÉCUPÉRATION (VER. RAL 7016)

PREMONTAJE DEPÓSITO DE RECUPERACIÓN (VER. RAL 7016)

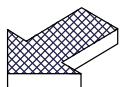
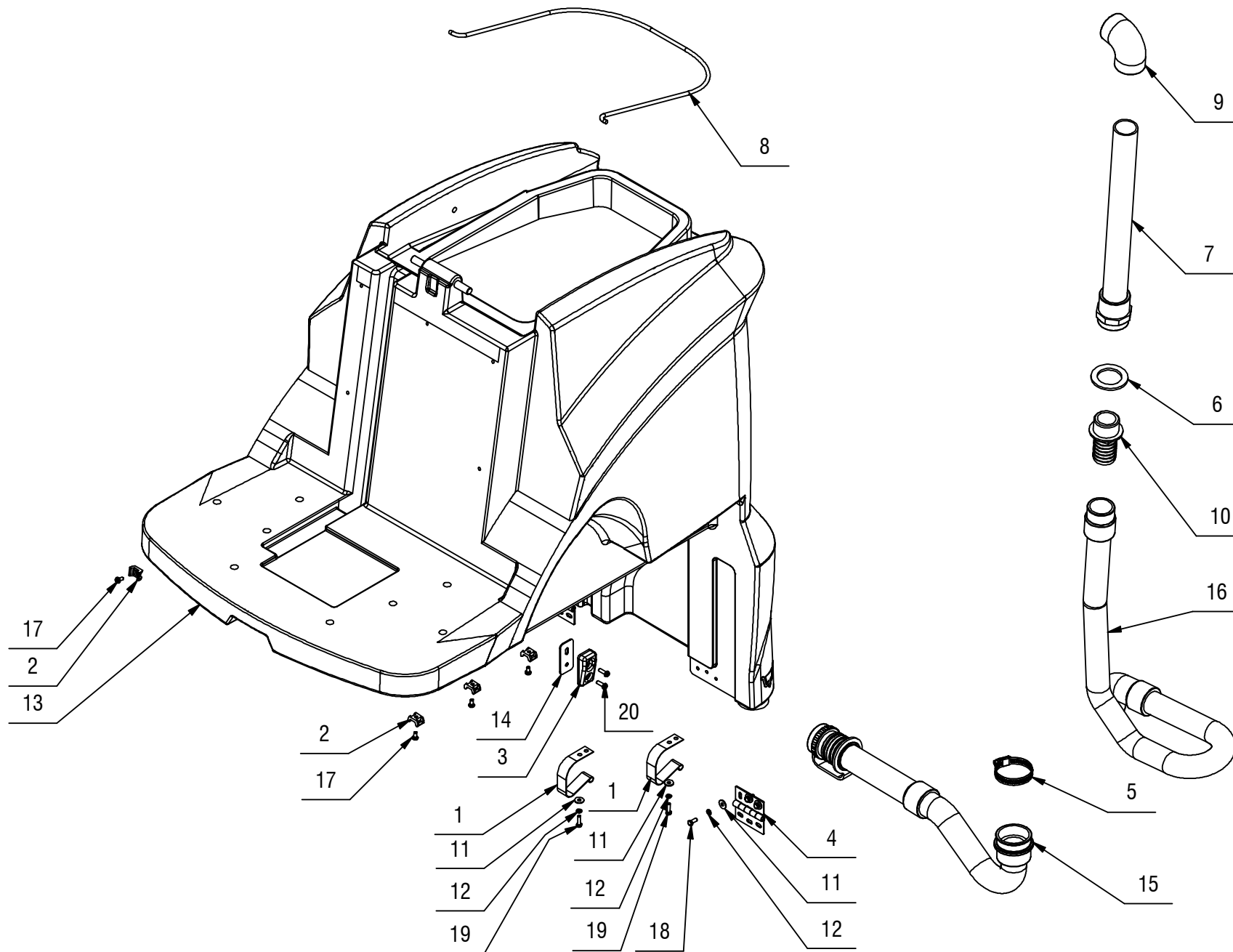

## CR-10 PRE-ASSEMBLY OF RECOVERY TANK (VER. RAL 7016)

10

-	POS	TECHNICAL NEWS	SERIAL NUMBER	CODICE	QTÀ	DESCRIZIONE	DESCRIPTION	DESIGNATION	DESCRIPCION
	1			203595	2	AGGANCIO TUBO SCARICO	COUPLER	ACCROCHAGE	ENGANCHE
	2			409819	5	BASETTA TC 142 PER FASCETTE	SUPPORT TC 142	PLAQUE SUPPORT	PLACA SOPORTE
	3			431190	2	CENTRAGGIO SERBATOIO REC. MMG	SHIM	EPAISSEUR	ESPEJOR
	4			400294	2	CERNIERA 64X64	HINGE	CHARNIERE	BISAGRA
	5			410287	1	FASCETTA A VITE 40-60 X 9	CLAMP	COLLIER	ABRAZADERA
	6			405960	1	GUARNIZIONE GOMMA PER RACCORDO 410397	GASKET	JOINT	JUNTA
	7			219470	1	PREM.TUBO ASPIRAZIONE 1 1/4" x Ø40 x 417	SUCTION HOSE	FLEXIBLE ASPIRATION	TUBO DE ASPIRACION
	8			430908	1	PUNTELLO COPERCHIO ASPIRAZIONE MMG	PROP FOR COVER	LEVIER DE COUVERCLE	PUNTAL CAPOTE
	9			431170	1	RACCORDO A GOMITO PVC INCOLLO DN 40x90°	ELBOW	COUDE	RACOR CODO
	10			410397	1	RACCORDO PORTAGOMMA DIRITTO D38	FITTING	RACCORD	RACOR
	11			409151	8	RONDELLA 5,5x15x1.5 UNI 6593 ZINC	WASHER 5,5x15x1.5 UNI 6593 ZINC	RONDELLE	ARANDELA
	12			409154	8	RONDELLA M5 UNI 1751 ZINC	WASHER M5 UNI 1751 ZINC	RONDELLE M5 UNI 1751 ZINC	ARANDELA M5 UNI 1751 ZINC
	13			451323	1	SERBATOIO RECUPERO MMG RAL 7016	RECOVERY TANK	RESERVOIR EAU SALE	TANQUE AGUA SUCIA
	14			431632	2	SPESSORE CENTRAGGIO SERB. REC. MMG	SHIM	EPAISSEUR	ESPEJOR
	15			431081	1	TUBO D.38X595 SPIR. MAN. D.50 CON TAPPO	EXHAUST PIPE ASSEMBLY	FLEXIBLE DE VIDANGE COMPL.	TUBO DE DESCARGA COMPLETO
	16			432091	1	TUBO DIAM. 38X1080 SPIRALATO CON GOMITO	SUCTION HOSE	FLEXIBLE ASPIRATION	TUBO DE ASPIRACION
	17			418311	5	VITE M5x10 TCTC UNI 7687 (4.8) ZINC.	SCREW	VIS	TORNILLO
	18			407644	6	VITE M5x12 TE UNI 5739 ZINC	SCREW	VIS	TORNILLO
	19			407645	2	VITE M5X16 UNI 5739 ZINC	SCREW M5x10 UNI 7687 ZINC	VIS	TORNILLO
	20			408854	4	VITE M5X16 UNI EN ISO 704	SCREW M5X16 UNI EN ISO 704	VIS	TORNILLO

CR-11 SUCTION MOTOR UNIT (VER. 24V 410W H1200 2ST)

UNITÉ MOTEUR D'ASPIRATION (VER. 24V 410W H1200 2ST)

UNIDAD MOTOR DE ASPIRACIÓN (VER. 24V 410W H1200 2ST)

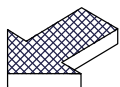
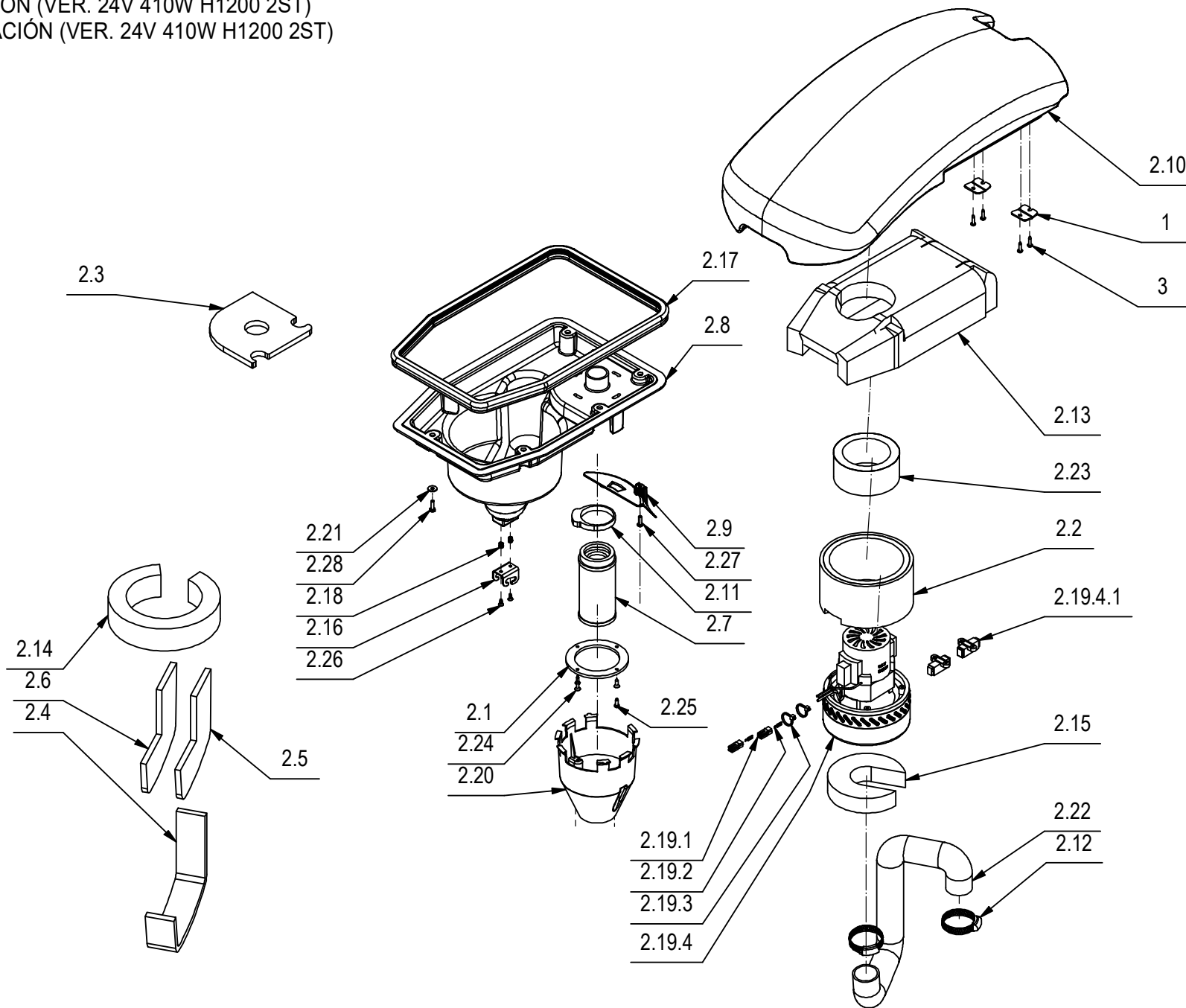

## CR-11 SUCTION MOTOR UNIT (VER. 24V 410W H1200 2ST)

11

-	POS	TECHNICAL NEWS	SERIAL NUMBER	CODICE	QTÀ	DESCRIZIONE	DESCRIPTION	DESIGNATION	DESCRIPCION
	1			426314	2	PIASTRINA FISSAGGIO PERNO ROTAZIONE	PLAQUE	PLAQUETTE	PLAQUETA
↓	2			219349	1	PREM. COPERCHIO ASPIRAZIONE MMG	ASSEMBLY SUCTION SYSTEM	GROUPE D'ASPIRATION	GRUPO ASPIRACION
↑	2.1			426884	1	ANELLO RINFORZO ALETTE GALLEGGIANTE	COMPENSATOR RING	ANNEAU DE COMPENSATEUR	ANILLO DE COMPENSADOR
↑	2.2			420025	1	ANTIROMBO 123.5X155 H85 MOT ASPIRAZ. M17	ANTIINOISE 123.5X155 H85	ANTIBRUIT 123.5X155 H85	ANTIRUIDO 123.5X155 H85
↑	2.3			426337	1	ANTIROMBO LISCIO ADES. 146X146 H10 - MAXI	DEADENING	ISOLANT PHONIQUE	FONOABSORBENTE
↑	2.4			426336	1	ANTIROMBO LISCIO ADES. 368X50 H10 - MAXI	DEADENING	ISOLANT PHONIQUE	SCHALLDICHTUNG
↑	2.5			426335	1	ANTIROMBO LISCIO ADES. H10 DX - MAXIMA	DEADENING	ISOLANT PHONIQUE	FONOABSORBENTE
↑	2.6			426334	1	ANTIROMBO LISCIO ADES. H10 SX - MAXIMA	DEADENING	ISOLANT PHONIQUE	FONOABSORBENTE
↑	2.7			412363	1	ASSIEME FILTRO A CARTUCCIA D=60 H=130	FILTER ASSEMBLY	FILTRE COMPLET	FILTRO COMPLETO
↑	2.8			426312	1	CARTER MOTORE ASPIRAZIONE MX	COVER	CARTER	CARTER
↑	2.9			426872	1	CONVOGLIATORE ACQUA MX	SUPPORT	SUPPORT	SOPORTE
↑	2.10			430915	1	COPERCHIO ASPIRAZIONE MMG	COVER	COUVERCLE	TAPA
↑	2.11			411988	1	FASCETTA A SCATTO	CLAMP	COLLIER	ABRAZADERA
↑	2.12			420512	2	FASCETTA A VITE 27/51x12,6 INOX	SCREW CLAMP	COLLIER VIS	ABRAZADERA A TORNILLO
↑	2.13			426341	1	FONOAS. BUGNATO ADES. 274X375 H30 - MAXI	DEADENING	ISOLANT PHONIQUE	FONOABSORBENTE
↑	2.14			426340	1	FONOAS. BUGNATO ADES. 45X420 H30	DEADENING	ISOLANT PHONIQUE	FONOABSORBENTE
↑	2.15			426339	1	FONOAS. BUGNATO ADES. D.130 H30 - MAXI	DEADENING	ISOLANT PHONIQUE	FONOABSORBENTE
↑	2.16			429952	1	GANCIO FERMO COFANO ASPIRAZIONE	HOOK	CROCHET	GANCHO
↑	2.17			221276	1	GUARNIZIONE CALOTTA ASPIR. MMX-MX-SMX	PROFILE	PROFIL	PERFIL
↑	2.18			430538	2	INSERTO PRESS-LOCK PLK-B-M4	INSERT	ENCART	INSERTO
↑↓	2.19			219723	1	PREM. MOT. ASP. 24V 310W H950 PERIF. 2ST	SUCTION MOTOR	MOTEUR D'ASPIRATION	MOTOR DE ASPIRACION
↑↑	2.19.1			409660	2	CONNETTORE 30A ROSSO M/F	CONNECTOR	CONNECTEUR	CONECTOR
↑↑	2.19.2			409661	2	CONTATTO CONNETT. ANDERS. 30A	CONTACT	CONTACT	CONTACTO
↑↑	2.19.3			410274	2	FASCETTA PLASTICA 2.5x98	CLAMP 2.5x98	COLLIER	ABRAZADERA
↑↑↓	2.19.4			430959	1	MOT. ASP. 24V 410W H1200 2ST S711267	SUCTION MOTOR	MOTEUR D'ASPIRATION	MOTOR DE ASPIRACION
↑↑↑	2.19.4.1			424210	2	SPAZZOLE MOTORE ASP. A471 EMB (11,2X71)	CARBON BRUSH MOTOR	CHARBON MOTEUR	ESCOBILLA MOTOR
↑	2.20			400727	1	PROTEZIONE GALLEGGIANTE	FLOAT PROTECTION	FLOTTEUR PROTECTION	PROTECCION FLOTADOR
↑	2.21			409152	5	RONDELLA D15 UNI 6593 AISI	WASHER D15 UNI 6593 AISI	RONDELLE	ARANDELA
↑	2.22			218330	1	TUBO ASPIRAZIONE D=38 L=550	SUCTION HOSE	FLEXIBLE ASPIRATION	TUBO DE ASPIRACION
↑	2.23			216250	1	TUBO FONOASSORBENTE D.110 d.80 H.50	DEADENING HOSE	TUYAU ISOLANT PHONIQUE	TUBO FONOABSORBENTE
↑	2.24			431501	2	VITE AUT. 4.2X16 TSPTC - RAPID-FIX - A2	SCREW	VIS	TORNILLO
↑	2.25			408879	2	VITE D.4,2x13 AUTOF. UNI 6954 A2	SCREW	VIS	TORNILLO
↑	2.26			415747	2	VITE M4X10 TSBTC UNI 7689 A2	SCREW	VIS	TORNILLO
↑	2.27			415849	1	VITE M5X16 TCBEI ISO 7380 A2	SCREW	VIS	TORNILLO
↑	2.28			407646	5	VITE M5x16 TE UNI 5739 A2	SCREW	VIS	TORNILLO
↑	2.29			429320	1	KIT CAVI CALOTTA ASPIR. MG75-85-85S-100	CABLE	CAVLE	CABLE
	3			431503	4	VITE AUT. 4.2X16 TCTC - UNI 6954 - A2	SCREW	VIS	TORNILLO

CR-13 WATER UNIT  
GROUPE HYDRIQUE  
GRUPO AGUA

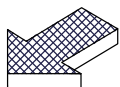
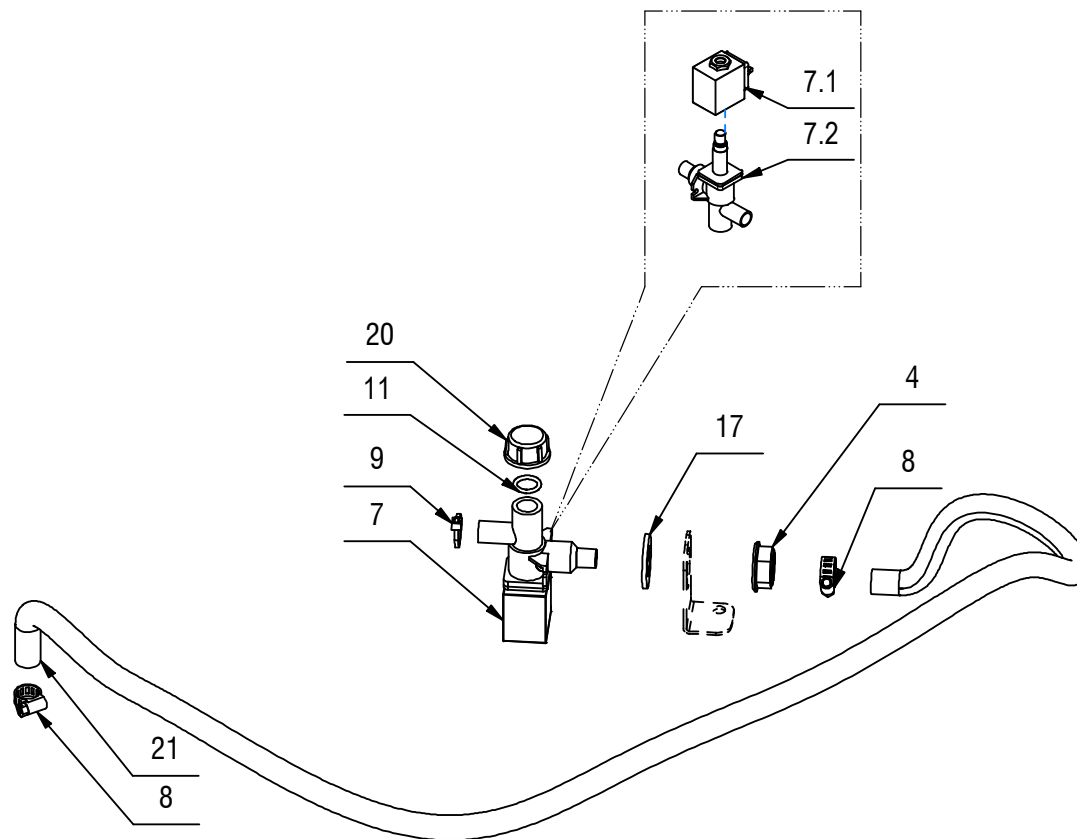
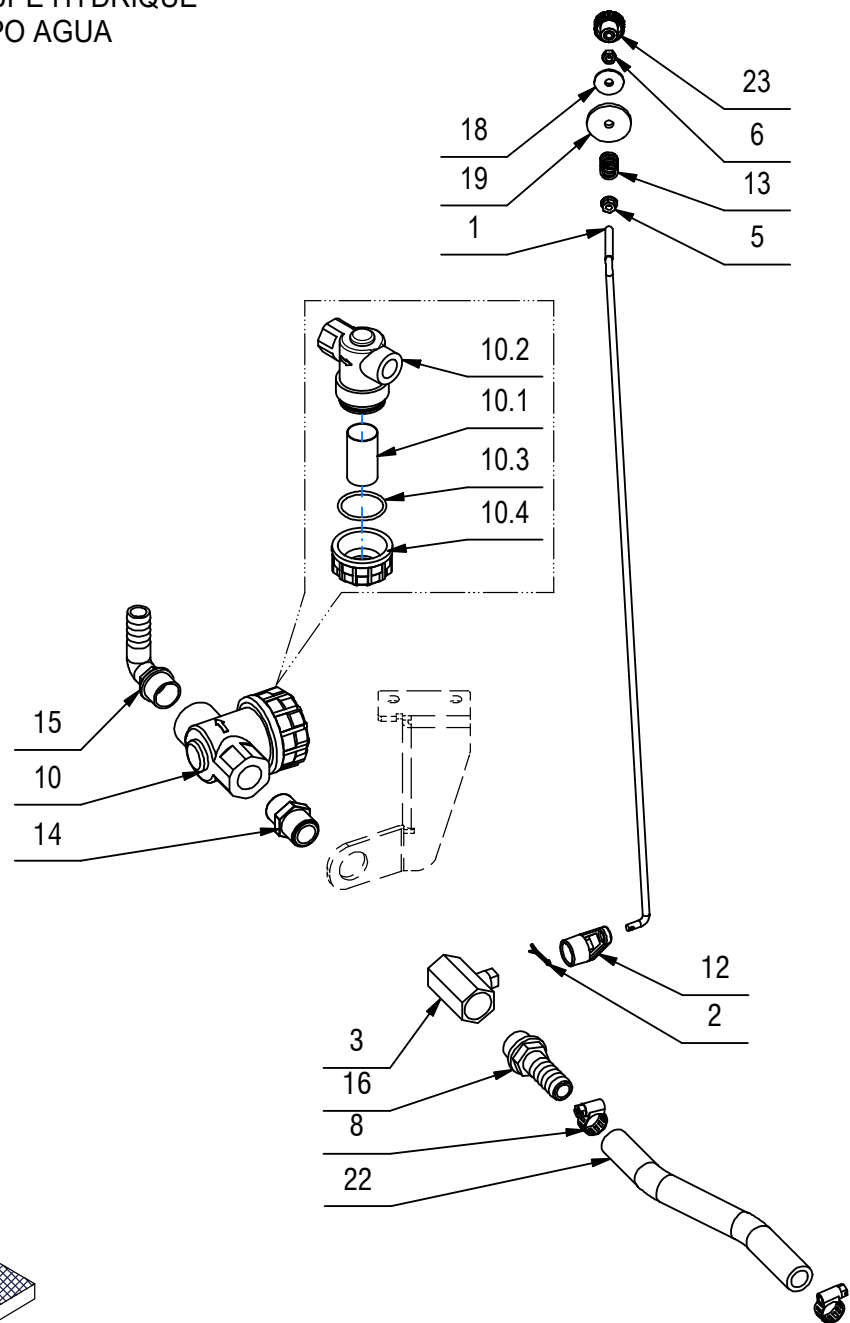



## CR-13 WATER UNIT

13

-	POS	TECHNICAL NEWS	SERIAL NUMBER	CODICE	QTÀ	DESCRIZIONE	DESCRIPTION	DESIGNATION	DESCRIPCION
	1			219363	1	ASTA RUBINETTO MMG	ROD	TIGE	VARILLA
	2			409383	1	COPIGLIA 2X20 UNI 1336 INOX	SPLIT PIN	GOUPILLE	PASADOR DE ALETAS
	3			410330	1	CORPO RUBINETTO 1/2" G FF	COCK	ROBINET	GRIFO
	4			410442	1	DADO FLANGIATO 1/2"	FLANGE NUT 1/2"	ÉCROU À BRIDE EN PLASTIQUE 1/2"	TUERCA BRIDA PLÁSTICO 1/2"
	5			409124	1	DADO M5 SERPRESS	NUT	ECROU	TUERCA
	6			417267	1	DADO M5 ZNT UNI 5588 DIN 934	NUT	ECROU	TUERCA
↓	7			407887	1	ELETTROVALVOLA COMPLETA 24V 1/2" ACL 3	SOLENOID VALVE COMPLETE 24V 1/2" ACL 3	ELECTROVANNE COMPLET 24V 1/2" ACL 3	ELECTROVALVULA COMPLETO 24V 1/2" ACL 3
↑	7.1			407866	1	BOBINA 24V 1/2 (PER ACL 407887)	COIL 24V 1/2 (PER ACL 407887)	BOBINE 24V 1/2 (PER ACL 407887)	BOBINA 24V 1/2 (PER ACL 407887)
↑	7.2			407859	1	CORPO ELETTROVALVOLA 1/2- V.24/36 (ACL)	SOLENOID VALVE BODY 1/2- V.24/36 (ACL)	CORPS D'ELECTROVANNE 1/2- V.24/36 (ACL)	CUERPO ELECTROVALVULA 1/2- V.24/36 (ACL)
	8			410292	4	FASCETTA A VITE 11/17 ABA	HOSE CLAMP 11/17 ABA	COLLIER A VIS 11/17 ABA	ABRAZADERA DE TORNILLO 11/17 ABA
	9			410274	1	FASCETTA PLASTICA 2.5x98	CLAMP 2.5x98	COLLIER	ABRAZADERA
↓	10			212616	1	FILTRO 1/2" F-F	FILTER ASSEMBLY	FILTRE COMPLET	FILTRO COMPLETO
↑	10.1			420949	1	CARTUCCIA FILTRO 1/2" F-F	FILTER CARTRIDGE	CARTOUCHE DE FILTRE	CARTUCHO FILTRO
↑	10.2			420947	1	CORPO FILTRO 1/2" F-F	FILTER	FILTRE	FILTRO
↑	10.3			420950	1	GUARNIZIONE TAPPO FILTRO 1/2" F-F	GASKET	JOINT	JUNTA
↑	10.4			420948	1	TAPPO FILTRO 1/2" F-F	COVER	COUVERCLE	TAPA
	11			408595	1	GUARNIZIONE OR 3056	O-RING 3056	JOINT	JUNTA
	12			400854	1	LEVA RUBINETTO CORTA	COCK LEVER	LEVIER DE ROBINET	PALANCA DE GRIFO
	13			408094	1	MOLLA 12x1,5x15	SPRING	RESSORT	RESORTE
	14			410420	1	NIPPLIO 1/2" M 1/2" M	NIPPLE	RACCORD	BOQUILLA ROSCADA
	15			410339	1	PORTAGOMMA A GOMITO 1/2" x D16	CONNECTOR	RACCORD	EMPALME TUBO DE GOMA
	16			410371	1	PORTAGOMMA DIRITTO 1/2"x16	CONNECTOR 1/2X16	RACCORD 1/2X16	EMPALME TUBO DE GOMA 1/2X16
	17			409230	1	RONDELLA 21x37x3 UNI 6592 ZINC	WASHER M20 UNI 6592 ZINC	RONDELLE M20 UNI 6592 ZINC	ARANDELA M20 UNI 6592 ZINC
	18			400250	1	RONDELLA D=5X20	SPECIAL WASHER D=5X20	RONDELLE SPECIALE	ARANDELA ESPECIAL
	19			409166	1	ROSETTA PVC 6x30x3 NERA	WASHER	RONDELLE	ARANDELA
	20			410409	1	TAPPO FEMMINA 1/2" - PLASTICA	CAP 1/2"	CAPUCHON	TAPON
	21			209623	1	TUBO D=20 d=14 L=1300 SPIRALATO TRASPAR.	PIPE	TUBE	TUBO
	22			209533	1	TUBO Di=13 De=20 L=220 PVC	PIPE	TUBE	TUBO
	23			410221	1	VOLANTINO D=20 L=16 M5	HANDWHEEL	VOLANT	RUEDA DE MANIOBRA

# CR-14 ELECTRIC COMPONENTS ASSEMBLY

GRUPE COMPOSANTS ELECTRIQUES

GRUPO COMPONENTES ELÉCTRICOS

14

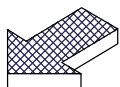
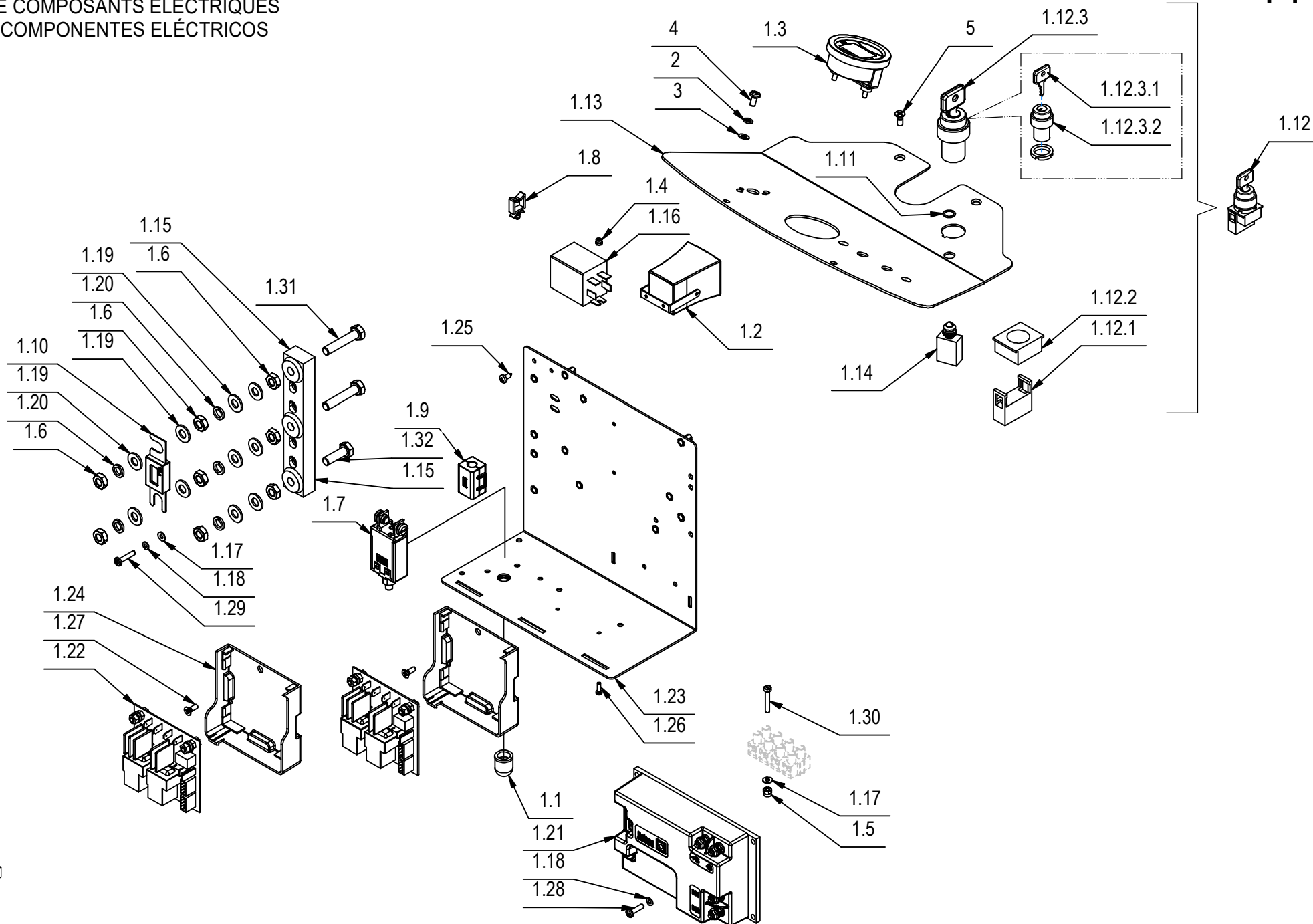

## CR-14 ELECTRIC COMPONENTS ASSEMBLY

14

-	POS	TECHNICAL NEWS	SERIAL NUMBER	CODICE	QTÀ	DESCRIZIONE	DESCRIPTION	DESIGNATION	DESCRIPCION
↓	1			221468	1	PREM. IMPIANTO ELETTRICO MR 65-75-85	ELECTRIC COMPONENTS ASSEMBLY	GROUPE COMPOSANTS ELECTRIQUES	GRUPO COMPONENTES ELÉCTRICOS
↑	1.1			411815	1	CAPPUCCIO DISGIUNTORE TERMICO	PROTECTION CAP	CAPUCHON	TAPON
↑	1.2			409789	1	CLAXON COMPLETO	HORN	KLAXON	BOCINA
↑	1.3			440063	1	CONTAORE CON INDICATORE BATTERIA NE306	HOUR METER AND BDI NE306	COMPTEUR HORAIRE	CUENTAHORAS
↑	1.4			409077	2	DADO M3x4,5 UNI 7474 ZINC	NUT M3x4,5 UNI 7474 ZINC	ECROU AUTOFREINES	TUERCA AUTOBLOCANTE
↑	1.5			409078	2	DADO M4x6 AUTOBL. UNI 7473 ZINC	LOCK NUT	ECROU AUTOFREINES	TUERCA AUTOBLOCANTE
↑	1.6			409048	8	DADO M8x5 UNI 5589 A2	NUT	ECROU	TUERCA
↑	1.7			411803	1	DISGIUNTORE 4130-G411-K4M1-60A	CONTACT BREAKER	DISJONCTEUR SECURITE	INTERRUPTOR SEGURIDAD
↑	1.8			430814	3	FERMACAVO WS A 2 01	CABLE FASTENER	FIXAGE DE CABLE	BRIDA CABLE
↑	1.9			409880	1	FERRITE A SCATTO MEC MSFC 8K	FERRITE SLEEVE CLAMP CORE	PINCE À MANCHON EN FERRITE	NÚCLEO DE PINZA DE MANGAS DE FERRITA
↑	1.10			409616	1	FUSIBILE PROTETTO 80A	FUSE	FUSIBLE	FUSIBLE
↑	1.11			437392	1	GUARNIZIONE LED BICOLORE "COD.1100"	GASKET	JOINT	JUNTA
↑↓	1.12			210516	1	INT. A CHIAVE COMPLETO (ELFI D.22)	KEY	CLEF	LLAVE
↑↑	1.12.1			409246	1	CONTATTO PER INTERRUTTORE A CHIAVE	CONTACT FOR SWITCH	CONTACT INTERRUPT.	CONTACTO INTERR.
↑↑	1.12.2			409262	1	FLANGIA PER INTERRUTTORE A CHIAVE	FLANGE	FLASQUE	BRIDA
↑↑↓	1.12.3			409261	1	INTERRUTTORE CON CHIAVI	SWITCH WITH KEY	INTERRUPTEUR A CLEF	INTERRUPTOR CON LLAVE
↑↑↑	1.12.3.1			409297	1	CHIAVE INTERRUTTORE	KEY	CLEF	LLAVE
↑↑↑	1.12.3.2			409261	1	CORPO INTERRUTTORE A CHIAVE	SWITCH BODY	CORPS INTERRUPTEUR	CUERPO INTERRUPTOR
↑	1.13			219342	1	LAMIERA CRUSCOTTO MMG	INSTRUMENT BOARD	TABEAU DE BORD	TABLERO DE INSTRUMENTOS
↑	1.14			437372	1	LED BICOL. ROSS/VERDE 24V FASTON 2.8x0.8	SIGNAL LAMP GREEN-RED	TEMOIN VERT-ROUGE	LAMPARA VERDE-ROJA
↑	1.15			409584	1	PORTA FUSIBILE LAMELLARE DOPPIO M8	FUSEHOLDER	PORTE-FUSIBLE	PORTAFUSIBLE
↑	1.16			407580	1	RELE FINDER 65.31 - 24V 30A 1 VIA FASTON	RELAY FINDER 65.31 - 24V 30A 1	RELAIS FINDER 65.31 - 24V 30A 1	RELE FINDER 65.31 - 24V 30A 1
↑	1.17			409142	4	RONDELLA 4x9x0,8 UNI 6592 ZINC	WASHER 4x9x0,8 UNI 6592 ZINC	RONDELLE	ARANDELA
↑	1.18			415941	6	RONDELLA D7,6 UNI1751 ZINC	WASHER D7,6 UNI1751 ZINC	RONDELLE FREIN	ARANDELLA DENTADA
↑	1.19			409176	10	ROSETTA 8x17x1.6 UNI 6592 OTTONE	WASHER	RONDELLE	ARANDELA
↑	1.20			409187	5	ROSETTA GROWER 8x13x2,2 A2	WASHER	RONDELLE	ARANDELA
↑	1.21			431309	1	SCHEDA CHOPPER 90A ITALSEA 7CH4Q90N	CHOPPER CARD	VARIATEUR ELECTRONIQUE	FICHA CHOPPER
↑	1.22			427687	2	SCHEDA RELE' 24V CON AUTORITENUTA	CARD RELAY	PLAQUE RELAIS	FICHA RELE
↑	1.23			219053	1	STAFFA SUPPORTO SCHEDA E CHOPPER MMG	SUPPORT	ATTAQUE	SOPORTE FIJADOR
↑	1.24			219054	2	SUPPORTO SCHEDA RELE' MMG	SUPPORT	SUPPORT	SOPORTE
↑	1.25			408870	2	VITE D.3,9x10 AUTOF. NICH UNI 6954	SCREW	VIS	TORNILLO
↑	1.26			408838	2	VITE M3x10 UNI 7687 ZINC	SCREW M3x10 UNI 7687 ZINC	VIS	TORNILLO
↑	1.27			415793	2	VITE M4X12 TPSTC UNI 7688 (4.8) ZINC	SCREW	VIS	TORNILLO
↑	1.28			408846	4	VITE M4X16 UNI 7687 ZINC	SCREW M4X16 UNI 7687 ZINC	VIS	TORNILLO
↑	1.29			408843	2	VITE M4x20 TCTC UNI 7687 A2	SCREW	VIS	TORNILLO

# CR-14 ELECTRIC COMPONENTS ASSEMBLY

GRUPE COMPOSANTS ELECTRIQUES  
GRUPO COMPONENTES ELÉCTRICOS

14

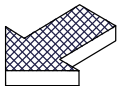
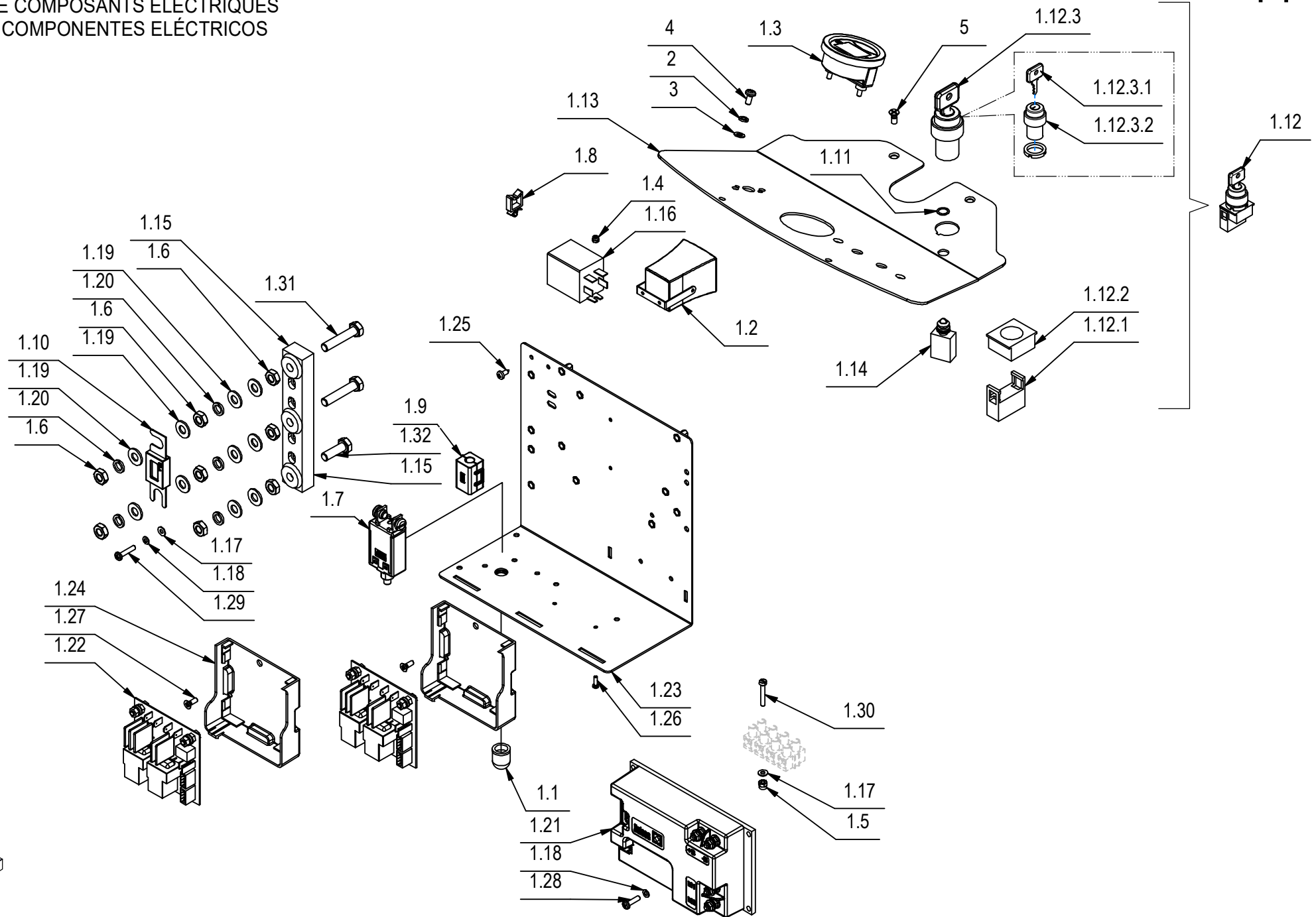

## CR-14 ELECTRIC COMPONENTS ASSEMBLY

14

-	POS	TECHNICAL NEWS	SERIAL NUMBER	CODICE	QTÀ	DESCRIZIONE	DESCRIPTION	DESIGNATION	DESCRPCIÓN
↑	1.30			408773	2	VITE M4x25 TC UNI 6107 A2	SCREW	VIS	TORNILLO
↑	1.31			408680	2	VITE M8X40 TE UNI 5739 A2	SCREW	VIS	TORNILLO
↑	1.32			408675	1	VITE M8x25 TE UNI5739 A2	SCREW	VIS	TORNILLO
	2			409154	2	RONDELLA M5 UNI 1751 ZINC	WASHER M5 UNI 1751 ZINC	RONDELLE M5 UNI 1751 ZINC	ARANDELA M5 UNI 1751 ZINC
	3			409150	2	ROSETTA 5X11X1 UNI 6592 ZINC	WASHER M5 UNI 6592 ZINC	RONDELLE M5 UNI 6592 ZINC	ARANDELA M5 UNI 6592 ZINC
	4			418311	2	VITE M5x10 TCTC UNI 7687 (4.8) ZINC.	SCREW	VIS	TORNILLO
	5			415750	2	VITE M5X12 TSPTC UNI 7688 (4.8) ZINC.	SCREW	VIS	TORNILLO

CR-15 NE328 24V 25A IEC BATTERY CHARGER GROUP

GRUPE CHARGEUR DE BATTERIE NE328 24V 25A IEC  
 GRUPO DE CARGADOR DE BATERÍA NE328 24V 25A IEC

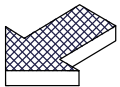
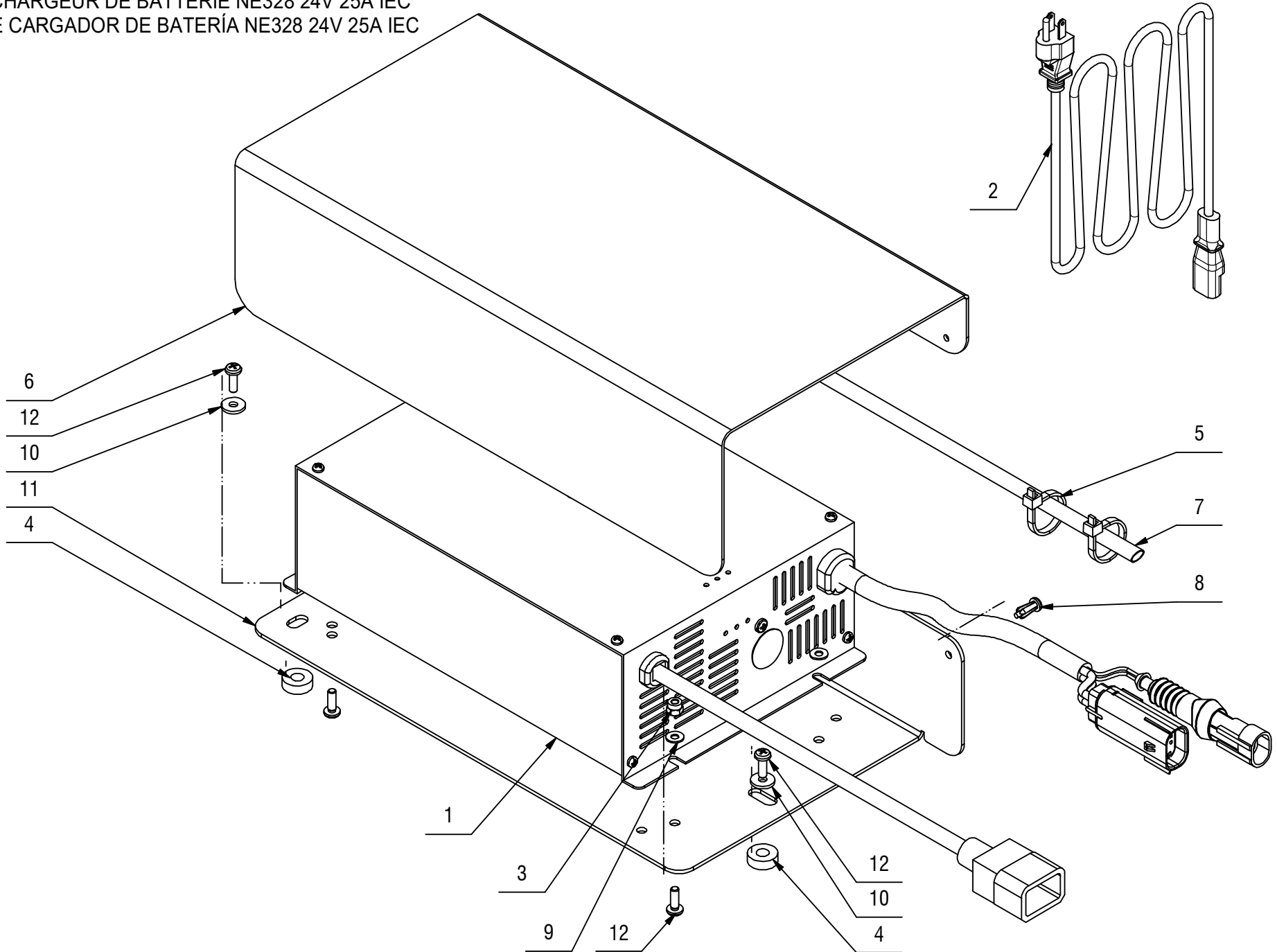

## CR-15 NE328 24V 25A IEC BATTERY CHARGER GROUP

15

-	POS	TECHNICAL NEWS	SERIAL NUMBER	CODICE	QTÀ	DESCRIZIONE	DESCRIPTION	DESIGNATION	DESCRIPCÓN
	1			446404	1	CARICABATTERIE NE328 24V 25A IEC	BATTERY CHARGERS	CHARGEURS	CARGADOR DE BATERIAS
	2			421359	1	CAVO SJT 3x18AWG 105 VW-1 L2M.SPINA USA	BATTERY CHARGER CABLE	CÂBLE CHARGEUR DE BATTERIE	CABLE CARGADOR DE BATERÍA
	3			409078	4	DADO M4x6 AUTOBL. UNI 7473 ZINC	LOCK NUT	ECROU AUTOFREINES	TUERCA AUTOBLOCANTE
	4			411760	3	DISTANZIALE D=15 d=6,5 S=5 PVC	SPACER	ENTRETOISE	DISTANCIADOR
	5			410275	2	FASCETTA PLASTICA 3,6x140 BIANCA	CLAMP	COLLIER	ABRAZADERA
	6			439370	1	GOMMA LUBRIT. PROTEZ. CARICABATT. MR	SPLASH GUARD	BAVETTE DE PROTECTION	PARASALPICADURAS
	7			223917	1	GUAINA TERMORESTRING. D.19x420	TERMIC SHEATH	GAINE THERMIQUE	VAINA TERMICA
	8			415954	3	RIVETTO D.4 PVC	RIVET	RIVET	CLAVO
	9			409143	4	RONDELLA 4X9X0,8 UNI 6592 AISI	WASHER 4X9X0,8 UNI 6592 AISI	RONDELLE	ARANDELA
	10			409144	3	ROSETTA 4,3x12x1,5 UNI 6593 ZINC	WASHER	RONDELLE	ARANDELA
	11			438991	1	STAFFA ADATTAMENTO C. BATT. SPE CBHD3	SUPPORT	SUPPORT	SOPORTE
	12			415778	7	VITE M4X12 TCTC UNI 7687 INOX A2	SCREW	VIS	TORNILLO

# CR-16 GROUP DECAL

GROUPES DE ETIQUETTE  
GRUPOS ETIQUETA

**WATER MANAGEMENT**

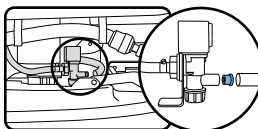

	l/h	
	55	1,50h
	42	2,30h
	25	4,10h

Portata acqua  
 Water flow  
 Caudal de agua  
 Débit d'eau  
 Wasserverbrauch

Autonomia  
 Autonomy  
 Autonomía  
 Autonomie

431630



428291

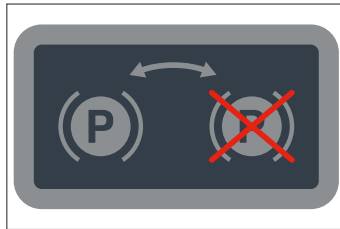

431102

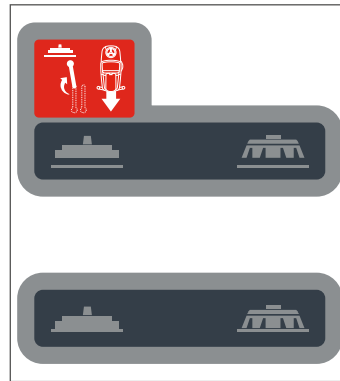

431084

**HILLYARD**

Scan for Service and Information



Escanear para Información y Servicio

460441

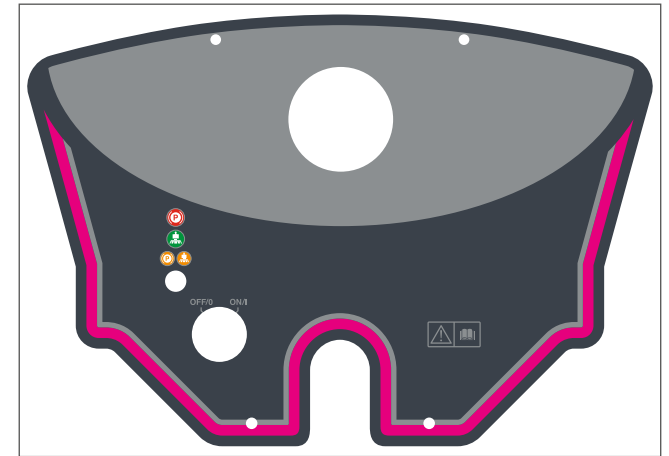

460396

**ATTENZIONI!**

Le batterie sono per il serbatoio. Non toccare le batterie con le mani nude o con un oggetto. Tenere sempre a portata di mano il manuale di istruzioni. Non toccare le batterie con le mani nude o con un oggetto. Tenere sempre a portata di mano il manuale di istruzioni. Non toccare le batterie con le mani nude o con un oggetto.

**ATTENTION!**

The batteries are for the tank. Do not touch the batteries with your bare hands or with an object. Keep the manual handy. Do not touch the batteries with your bare hands or with an object. Do not touch the batteries with your bare hands or with an object.

**¡ATENCIÓN!**

Las baterías están para el tanque. No toque las baterías con las manos desnudas o con un objeto. Mantenga siempre a mano el manual de instrucciones. No toque las baterías con las manos desnudas o con un objeto. Mantenga siempre a mano el manual de instrucciones. No toque las baterías con las manos desnudas o con un objeto.

**ACHTUNG!**

Die Batterien sind für den Tank. Berühre die Batterien nicht mit bloßen Händen oder einem Gegenstand. Halte das Handbuch immer zur Hand. Berühre die Batterien nicht mit bloßen Händen oder einem Gegenstand. Halte das Handbuch immer zur Hand. Berühre die Batterien nicht mit bloßen Händen oder einem Gegenstand.

**ATTENZIONE!**

Le batterie sono per il serbatoio. Non toccare le batterie con le mani nude o con un oggetto. Tenere sempre a portata di mano il manuale di istruzioni. Non toccare le batterie con le mani nude o con un oggetto. Tenere sempre a portata di mano il manuale di istruzioni. Non toccare le batterie con le mani nude o con un oggetto.

**ATTENTION!**

The batteries are for the tank. Do not touch the batteries with your bare hands or with an object. Keep the manual handy. Do not touch the batteries with your bare hands or with an object. Do not touch the batteries with your bare hands or with an object.

**¡ATENCIÓN!**

Las baterías están para el tanque. No toque las baterías con las manos desnudas o con un objeto. Mantenga siempre a mano el manual de instrucciones. No toque las baterías con las manos desnudas o con un objeto. Mantenga siempre a mano el manual de instrucciones. No toque las baterías con las manos desnudas o con un objeto.

**ACHTUNG!**

Die Batterien sind für den Tank. Berühre die Batterien nicht mit bloßen Händen oder einem Gegenstand. Halte das Handbuch immer zur Hand. Berühre die Batterien nicht mit bloßen Händen oder einem Gegenstand. Halte das Handbuch immer zur Hand. Berühre die Batterien nicht mit bloßen Händen oder einem Gegenstand.

437703

**NEARNESS OF BATTERIES**

Caricare la batteria solamente quando il display o le spia sul cruscotto indicano il livello zero. Il tempo di ricarica della batteria deve essere di minimo 12 ore. Attendere sempre l'espansione del led verde prima di considerare terminata la ricarica.

**BATTERY CHARGING**

Charge the battery only when the display or the lights of the instrument board indicate level zero. Charge time of the battery must be at least 12 hours. Always wait for the expanding of the green led, only then the recharge has been completed.

**CARGA DE LA BATERIA**

Cargar la batería solamente cuando el nivel batería y las luces placas sobre el tablero de instrumentos indican el nivel cero. El tiempo de carga de la batería es de 12 horas como mínimo. Esperar siempre al parpadear de la led verde antes de considerar la recarga terminada.

**RECHARGE DES BATTERIES**

Chargez la batterie seulement quand le témoin de batterie ou la lampe témoin sur le tableau de bord indiquent le niveau zéro. Le temps de recharge de la batterie doit être au minimum de 12 heures. Attendez toujours l'allumage du led vert avant de considérer la recharge terminée.

**WIEDERAUFLADEN DER BATTERIEN**

Die Batterie darf nur geladen werden, wenn die Batterie-Standanzzeige oder die Batteriekontrollleuchte den Batteriestand von Null anzeigt. Die Ladezeit der Batterie muss mindestens 12 Stunden betragen. Warten Sie immer bis die Anzeige grün aufleuchtet, erst dann ist die Ladeung vollständig durchgeführt.

- Chiudere il rubinetto a fine lavoro
- Turn off the cock when operations are finished
- Cerrar el grifo al finalizar el trabajo
- Ferme le robinet à la fin du travail
- Die Hahn bei Arbeitsabschluss schließen

- Pulire periodicamente l'equipaggiamento e i filtri
- Clean the equipment and the filters
- Limpiar a diario la herramienta de trabajo y los filtros
- Nettoyer le socat et les filtres tous les jours
- Regelmäßig Reinigung des Saugrohrs und der Filter

Do not go near to the brush head while the brush is moving.



460400











HILLYARD INDUSTRIES - PO Box 909 - St. Joseph, Missouri 64502-0909 U.S.A. - Telephone: 816-233-1321 - [www.hillyard.com](http://www.hillyard.com)