

2-Way Square Corner Replacement Entry Latch

Satin Nickel

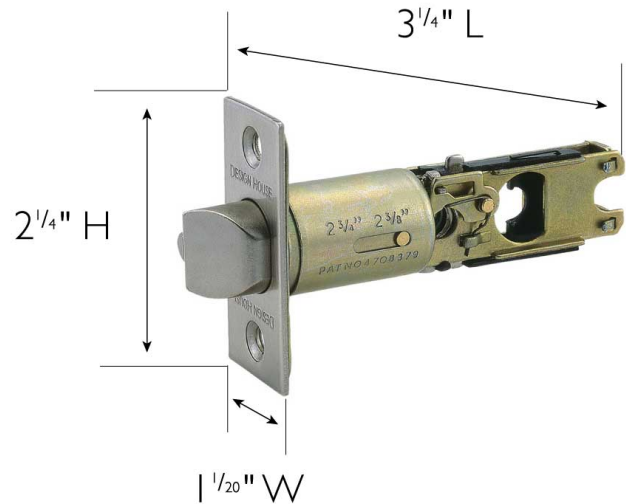

SPECIFICATIONS

MATERIAL CONSTRUCTION:	Zinc	REMOVABLE CORE:	No
LOCK FUNCTION:	Latch	LATCH FACEPLATE I:	Universal (Drive In)
DEADBOLT FUNCTION:	N/A	LATCH BACKSET:	Adj; 2-3/8" - 2-3/4"
EXTERIOR MAX PROJECTION:	0	LATCH TYPE:	2 Way (fixed faceplate)
INTERIOR MAX PROJECTION:	0	LATCHBOLT THROW DISTANCE:	0.5"
ASSEMBLED WEIGHT:	0.25 lbs.	SPINDLE TYPE:	Square
ASSEMBLED HEIGHT:	2.25"	MOUNTING HARDWARE INCLUDED:	Yes
ASSEMBLED LENGTH:	3.25"	TOOLS NEEDED FOR INSTALLATION:	Phillips Screwdriver
ASSEMBLED WIDTH/DEPTH:	1.05"		
CROSS BORE:	2.13"		
EDGE BORE:	1"		
HANDING:	Reversible		

WARRANTY:	5-Year limited warranty
ANSI CERTIFICATION:	Grade 3
BHMA GRADE:	3
FIRE RATED:	No
ADA COMPLIANT:	No



TYPE: JOB: ORDER CODE: APPROVALS:
--