



by HILLYARD

**EX7 Carpet Extractor**

**HIL56084**

**Operating Instructions (ENG)**

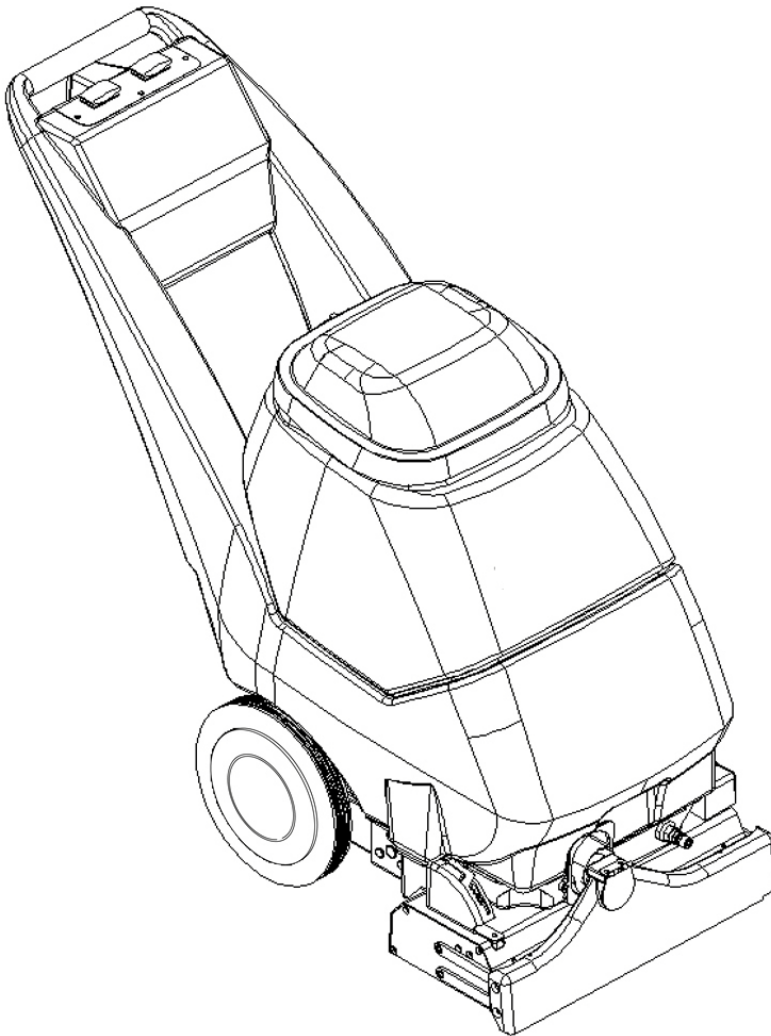

86430330-A 10/02/18

Model: \_\_\_\_\_

Date of Purchase: \_\_\_\_\_

Serial Number: \_\_\_\_\_

Dealer: \_\_\_\_\_

Address: \_\_\_\_\_

Phone Number: \_\_\_\_\_

Sales Representative: \_\_\_\_\_

This carpet extractor is an electrical powered, portable carpet extractor intended for commercial use. The appliance sprays a cleaning solution onto the carpet agitates the wet carpet, and then extracts the soiled solution back into the unit's recovery tank. The appliance is fitted with and a hand tool for cleaning upholstery and stairs.

**WARRANTY REGISTRATION**

Register through your Authorized Trident Dealer

**Machine Data Label . . . . .2**  
**Table of Contents . . . . .3**  
**How To Use This Manual . . . . .4**

*Safety*

Grounding Instructions: . . . . .5  
 IMPORTANT SAFETY INSTRUCTIONS . . . . .6  
 HAZARD INTENSITY LEVEL . . . . .8  
 Safety Labels . . . . .10

*Operations*

Technical Specifications . . . . .12  
 Controls. . . . .14  
 Components . . . . .15  
 Components - continued. . . . .16  
 Filling the EX7. . . . .17  
 Machine Operation . . . . .19  
 Cleaning Procedure . . . . .20  
 Accessory Tool Usage . . . . .23

*Maintenance*

Service Schedule . . . . .24  
 Periodic Maintenance . . . . .25  
 Daily / Regular Maintenance . . . . .25  
 Vacuum Motor Replacement . . . . .26  
 Belt Replacement . . . . .27  
 Solution Pump Replacement . . . . .28  
 Troubleshooting Chart . . . . .29

## How To Use This Manual

This manual contains the following sections:

- How to Use This Manual
- Safety
- Operations
- Maintenance

The HOW TO USE THIS MANUAL section will tell you how to find important information for ordering correct repair parts.

Parts may be ordered from authorized dealers. When placing an order for parts, the machine model and machine serial number are important. Refer to the MACHINE DATA box which is filled out during the installation of your machine. The MACHINE DATA box is located on the inside of the front cover of this manual.

Model: \_\_\_\_\_  
Date of Purchase: \_\_\_\_\_  
Serial Number: \_\_\_\_\_  
Dealer: \_\_\_\_\_  
Address: \_\_\_\_\_  
Phone Number: \_\_\_\_\_  
Sales Representative: \_\_\_\_\_

The model and serial number of your machine is located on the bottom back-end of the machine.

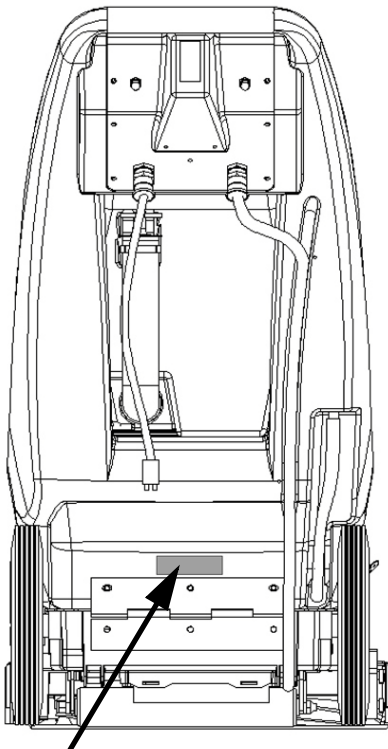

The SAFETY section contains important information regarding hazardous or unsafe practices of the machine. Levels of hazards are identified that could result in product damage, personal injury, or severe injury resulting in death.

The OPERATIONS section is to familiarize the operator with the operation and function of the machine.

The MAINTENANCE section contains preventive maintenance to keep the machine and its components in good working condition. They are listed in this general order:

- Periodic Maintenance
- Daily/Regular Maintenance
- Troubleshooting

*NOTE: If a service or option kit is installed on your machine, be sure to keep the KIT INSTRUCTIONS which came with the kit. It contains replacement parts numbers needed for ordering future parts.*

*NOTE: The manual part number is located on the lower right corner of the front cover.*

## Electrical:

In the USA, this machine operates on a standard 15 amp 115V, 60 Hz, A.C. power circuit. The amp, hertz, and voltage are listed on the data label found on each machine. Using voltages above or below those indicated on the data label will cause serious damage to the motors.

## Extension Cords:

If an extension cord is used, the wire size must be at least one size larger than the power cord on the machine, and must be limited to 50 feet (15.5m) in length.

## Grounding Instructions:

This appliance must be grounded. If it should malfunction or break down, grounding provides a path of least resistance for electric current to reduce the risk of electric shock. This appliance is equipped with a cord having an equipment-grounding conductor and grounding plug. The plug must be inserted into an appropriate outlet that is properly installed and grounded in accordance with all local codes and ordinances.

This appliance is for use on a nominal 120-volt circuit, and has a grounded plug that looks like the plug in "Fig. A". A temporary adaptor that looks like the adaptor in "Fig. C" may be used to connect this plug to a 2-pole receptacle as shown in "Fig. B", if a properly grounded outlet is not available. The temporary adaptor should be used only until a properly grounded outlet (Fig. A) can be installed by a qualified electrician. The green colored rigid ear, lug, or wire extending from the adaptor must be connected to a permanent ground such as a properly grounded outlet box cover. Whenever the adaptor is used, it must be held in place by a metal screw.

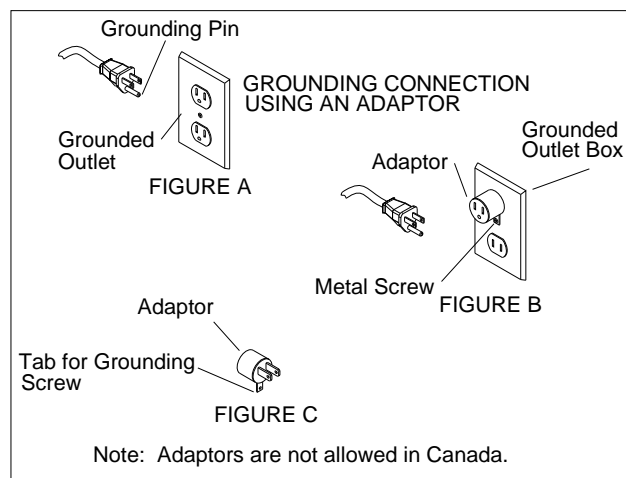

## ⚠ WARNING:

Improper connection of the equipment-grounding conductor can result in a risk of electric shock. Check with a qualified electrician or service person if you are in doubt as to whether the outlet is properly grounded. Do not modify the plug provided with the appliance - if it will not fit the outlet; have a proper outlet installed by a qualified electrician.

## ⚠ AVERTISSEMENT:

Le raccordement incorrect du conducteur de terre d'équipement peut entraîner des risques d'électrocution. Vérifiez auprès d'un électricien qualifié ou d'un responsable de l'entretien si vous avez quelque doute que ce soit quant au raccordement à la terre de votre prise murale. Ne modifiez pas la fiche fournie avec l'appareil : si elle ne correspond pas à la prise murale, faites installer une prise adéquate par un électricien qualifié. Utilisez-le uniquement sur des réceptacles protégés GFCI.

# IMPORTANT SAFETY INSTRUCTIONS

When using this machine, basic precaution  
must always be followed, including the following:  
**READ ALL INSTRUCTIONS BEFORE USING THIS MACHINE.**

## **WARNING:**

To reduce the risk of fire, electric shock, or injury:

Connect to a properly grounded outlet. See Grounding Instructions.

Do not leave the machine unattended. Unplug machine from outlet when not in use and before maintenance or service.

Use only indoors. Do not use outdoors or expose to rain.

Do not allow machine to be used as a toy. Close attention is necessary when used by or near children.

Use only as described in this manual. Use only manufacturer's recommended components and attachments.

Do not use damaged electrical cord or plug. Follow all instructions in this manual concerning grounding the machine. If the machine is not working properly, has been dropped, damaged, left outdoors, or dropped into water, return it to an authorized service center.

Do not pull or carry machine by electrical cord, use as a handle, close a door on cord, or pull cord around sharp edges or corners.

Do not run machine over cord. Keep cord away from heated surfaces.

Do not unplug machine by pulling on cord. To unplug, grasp the electrical plug, not the electrical cord.

Do not handle the electrical plug or machine with wet hands.

Do not operate the machine with any openings blocked. Keep openings free of debris that may reduce airflow.

This machine is intended for cleaning carpet only.

Do not vacuum anything that is burning or smoking, such as cigarettes, matches, or hot ashes.

This machine is not suitable for picking up health endangering dust.

Turn off all controls before unplugging.

Do not operate this machine near flammable fluids, dust or vapors.

Maintenance and repairs must be done by qualified personnel.

If foam or liquid comes out of machine, switch off immediately.

# READ AND SAVE THESE INSTRUCTIONS

# IMPORTANTES MESURES DE SÉCURITÉ

L'utilisation d'un appareil électrique demande certaines précautions:

LIRE TOUTES LES INSTRUCTIONS AVANT DE FAIRE FONCTIONNER (CET APPAREIL).

**⚠ AVERTISSEMENT:** Pour réduire les risques d'incendie, de choc électrique ou de blessure:

Cet appareil ne doit être connecter qu a des prises ayant une sortie de terre.

Ne pas laisser l'appareil sans surveillance lorsqu'il est branché. Débrancher lorsque l'appareil n'est pas utilisé et avant l'entretien.

Pour reduire les risques de choc electrique, ne pas utiliser à l exterieur et ne pas aspirer de matières humides.

Ne pas permettre aux enfants de jouer avec l'appareil. Une attention particulière est nécessaire lorsque l'appareil est utilisé par des enfants ou à proximité de ces derniers.

Utiliser cet appareil conformément aux instructions du présent manuel uniquement. N'utiliser que les composants et les accessoires conseillés par le fabricant.

Ne pas utiliser si le cordon ou la fiche est endommagé. Retourner l'appareil à un atelier de réparation s'il ne fonctionne pas bien, s'il est tombé ou s'il a été endommagé, oublié à l'extérieur ou immergé.

Ne pas tirer soulever ou traîner l'appareil par le cordon. Ne pas utiliser le cordon comme une poignée, le coincer dans l'embrasure d'unée porte ou l'appuyer contre des arêtes vives ou des coins. Ne pas faire rouler l'appareil sur le cordon.

Garder le cordon à l'écart des surfaces chaudes.

Ne pas débrancher en tirant sur le cordon. Tirer plutôt la fiche.

Ne pas toucher la fiche ou l'appareil lorsque vos mains sont humides.

N'insérer aucun objet dans les ouvertures. Ne pas utiliser l'appareil lorsqu'une ouverture est bloquée. S'assure que de la poussière, de la peluche, des cheveux ou d'autres matières ne réduisent pas le débit d'air.

Cette machine est destinée pour nettoyer le tapis seulement.

Ne pas aspirer de matières en combustion ou qui dégagent de la fumée, comme des cigarettes, des allumettes ou des cendres chaudes..

Cette machine n'est pas adaptée au ramassage de poussières dangereuses.

Mettre toutes les commandes à la position ARRÊT avant de débrancher l'appareil.

Ne pas aspirer des liquides inflammables ou combustibles, comme de l'essence, et ne pas faire fonctionner dans des endroits où peuvent se trouver de tels liquides.

L'entretien et les réparations de la machine doivent être effectuées par un personnel qualifié.

Si de la mousse ou du liquide sort de la machine, la mettre hors tension immédiatement.

## CONSERVER CES INSTRUCTIONS

The following symbols are used throughout this guide as indicated in their descriptions:

### HAZARD INTENSITY LEVEL

There are three levels of hazard intensity identified by signal words -**WARNING** and **CAUTION** and **FOR SAFETY**. The level of hazard intensity is determined by the following definitions:



**WARNING** - Hazards or unsafe practices which COULD result in severe personal injury or death.



**CAUTION** - Hazards or unsafe practices which could result in minor personal injury or product or property damage.

#### ***FOR SAFETY: To Identify actions which must be followed for safe operation of equipment.***

Report machine damage or faulty operation immediately. Do not use the machine if it is not in proper operating condition. Following is information that signals some potentially dangerous conditions to the operator or the equipment. Read this information carefully. Know when these conditions can exist. Locate all safety devices on the machine. Please take the necessary steps to train the machine operating personnel.

#### ***FOR SAFETY:***

**DO NOT OPERATE MACHINE:**

Unless Trained and Authorized.

Unless Operation Guide is Read and understood.

In Flammable or Explosive areas.

In areas with possible falling objects

#### ***WHEN SERVICING MACHINE:***

**Avoid moving parts. Do not wear loose clothing; jackets, shirts, or sleeves when working on the machine.**

**Use manufacturer approved replacement parts.**



Les symboles ci-dessous sont utilisés à travers ce manuel comme illustré dans leurs descriptions :

## DEGRÉS DE RISQUES EN CAS DE DANGER

Il existe trois degrés de risques identifiés par les termes signalétiques –**AVERTISSEMENT** et **ATTENTION** et **POUR VOTRE SÉCURITÉ**. Le degré de risque est défini de la manière suivante :

### **⚠ AVERTISSEMENT:**

**AVERTISSEMENT** - Dangers ou méthodes dangereuses qui **POURRAIENT** provoquer de graves blessures ou entraîner la mort.

### **⚠ ATTENTION:**

**ATTENTION** - Dangers ou méthodes dangereuses qui pourraient provoquer des blessures légères ou une détérioration du produit ou des biens immobiliers.

***POUR VOTRE SÉCURITÉ : ce signe permet d'identifier les mesures de précaution à prendre pour assurer un bon fonctionnement du matériel.***

Rendre compte immédiatement d'une défaillance ou d'une détérioration de la machine. Ne pas utiliser la machine si celle-ci ne fonctionne pas correctement. Lire soigneusement les informations ci-dessous signalant certains dangers potentiels pour l'opérateur de la machine. L'opérateur doit être absolument au courant de ces dangers potentiels. Localiser tous les dispositifs de sécurité sur la machine. Il est conseillé de prendre les mesures nécessaires pour former le personnel opérateur.

#### ***POUR VOTRE SÉCURITÉ :***

**NE PAS MANOEUVRER LA MACHINE :**

Lorsqu'on n'est pas expérimenté ou qualifié.

Lorsque le guide d'utilisation n'est pas été lu ou compris.

Dans des zones inflammables ou explosives.

Dans des zones où des objets peuvent tomber.

#### ***LORS DE L'ENTRETIEN DE LA MACHINE :***

Éviter les pièces mobiles. Ne pas porter de vêtements, vestes, chemises ou manches vagues lors de l'entretien de la machine. Utiliser les pièces de rechange approuvées par le fabricant.

## Safety Labels

*NOTE: These drawings indicate the location of safety labels on the machine. If at any time the labels become illegible, promptly replace them.*

## Emplacement De L'étiquette De Sécurité

*REMARQUE : Ces dessins indiquent l'emplacement des étiquettes de sécurité sur la machine. Si, à tout moment, les étiquettes deviennent illisibles, contactez votre représentant autorisé pour un remplacement rapide.*

### 86242230 WARNING LABEL

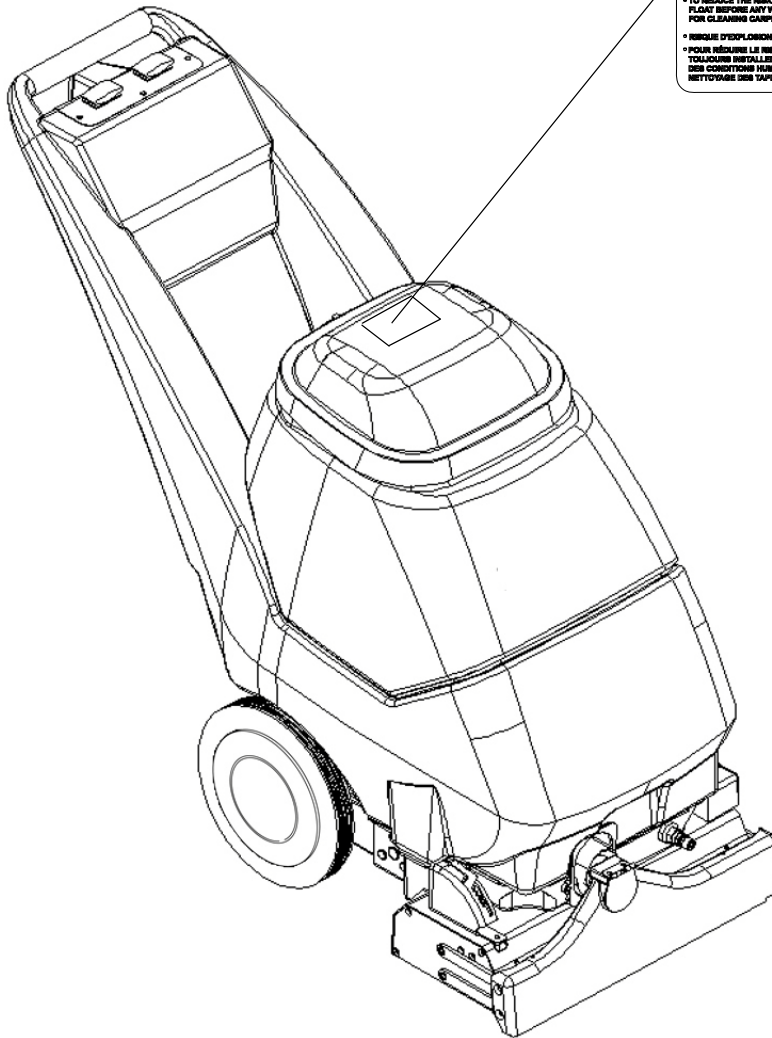
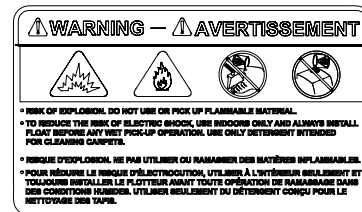



## Technical Specifications

ITEM	DIMENSION/CAPACITY
Weight	92lbs (42kg)
Length	41 inches (104cm)
Height	34 inches (86.4cm)
Width	17.5 inches (44.5cm)
Wheels	2x 10 in (25 cm) Diameter wheels by 2 in
Solution Spray	2 Quick Change Jets
Power Cable	50 Feet (12.7 m)
Vacuum Shoe	17 in (43.2 cm) cast aluminum with spring loaded down pressure.
Electrical	115 V, 15 A, 60 HZ
Electrical Vacuum Motor	3 stage, 1.5 hp, 100 cfm (2.80 cubic meters/min.), Waterlift 120 inches (304 cm)
Brush	15 inch (38.1 cm.)
Brush Speed	1000 rpm
Solution Pump	90 PSI, Diaphragm style, internal bypass
Solution Capacity	7 gallons (26.5ltr)
Recovery Capacity	7 gallons (26.5ltr)

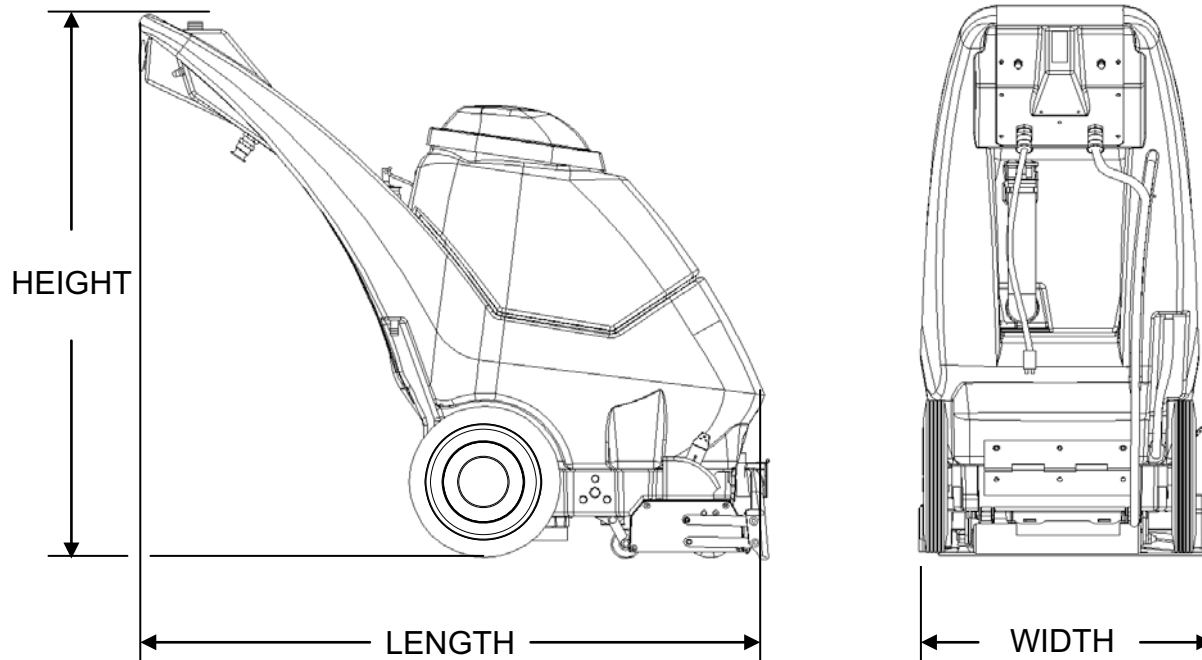
**⚠ CAUTION:**

This appliance is not intended for use by persons (including children) with reduced physical, sensory or mental capabilities, or lack of experience and knowledge, unless they have been given supervision or instruction concerning use of the appliance by a person responsible for their safety. Children should be supervised to ensure that they do not play with the appliance.

**⚠ ATTENTION:**

Cet appareil n'est pas prévu à l'usage des personnes (enfants y compris) avec des possibilités physiques, sensorielles ou mentales réduites, ou le manque d'expérience et de connaissance, à moins qu'ils aient été donnés la surveillance ou l'instruction au sujet de l'utilisation de l'appareil par une personne chargée de leur sûreté. Des enfants devraient être dirigés pour s'assurer qu'ils ne jouent pas avec l'appareil.

## Controls

1. **Main Handle.** Used to pull and maneuver machine.
2. Electrical Cord.
3. **Pump Switch.** Turns on pump and enables spray.
4. **Brush/Spray switch.** Turns on brush motor and activates electro-valve to dispense solution to floor through jets. Intermittent, off, and continuous settings.
5. **Vacuum Motor Switch.** Turns on vacuum motor.
6. **Brush Motor Circuit Breaker.** 6 amp. Breaker protecting brush motor.
7. **Vacuum Motor Circuit Breaker.** 15 amp. Breaker protecting vacuum motor.
8. **Recovery Dump Hose.** Facilitates draining dirty cleaning solution.
9. **Solution Dump Hose.** Facilitates draining excess cleaning solution from solution tank.

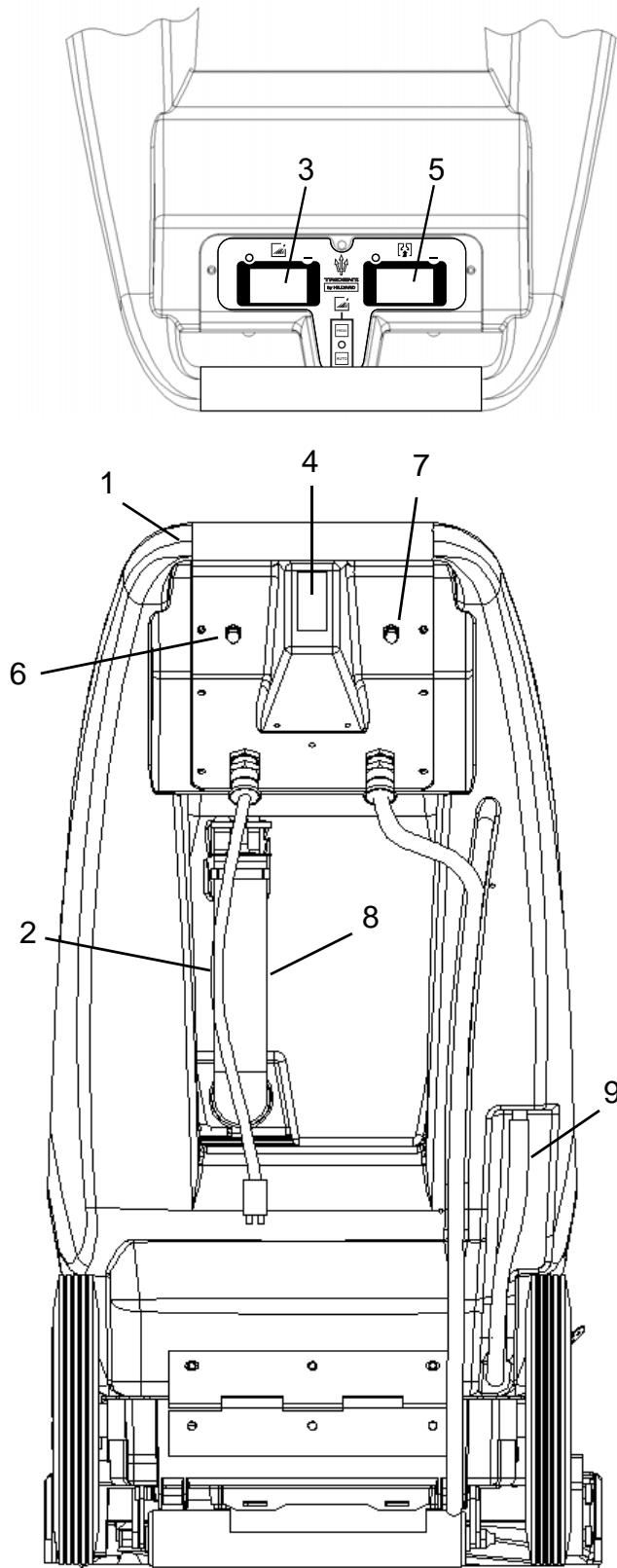

## Components

1. **Solution Accessory Tool Hookup.** Used for various auxiliary cleaning tools.
2. **Vacuum Hose Door.** Used to connect various auxiliary 1 1/2 inch cleaning tool vacuum hoses.
3. **Brush Height Adjustment.** Used to regulate brush height from storage position to various carpet heights.
4. **Recovery Tank.** Used to collect dirty cleaning solution.
5. **Solution Tank.** Used to hold cleaning solution.
6. Recovery Tank Dome.
7. Vacuum Shoe.
8. Brush Housing.
9. Front Lifting Handle.
10. **Cleaning Solution Filter.**

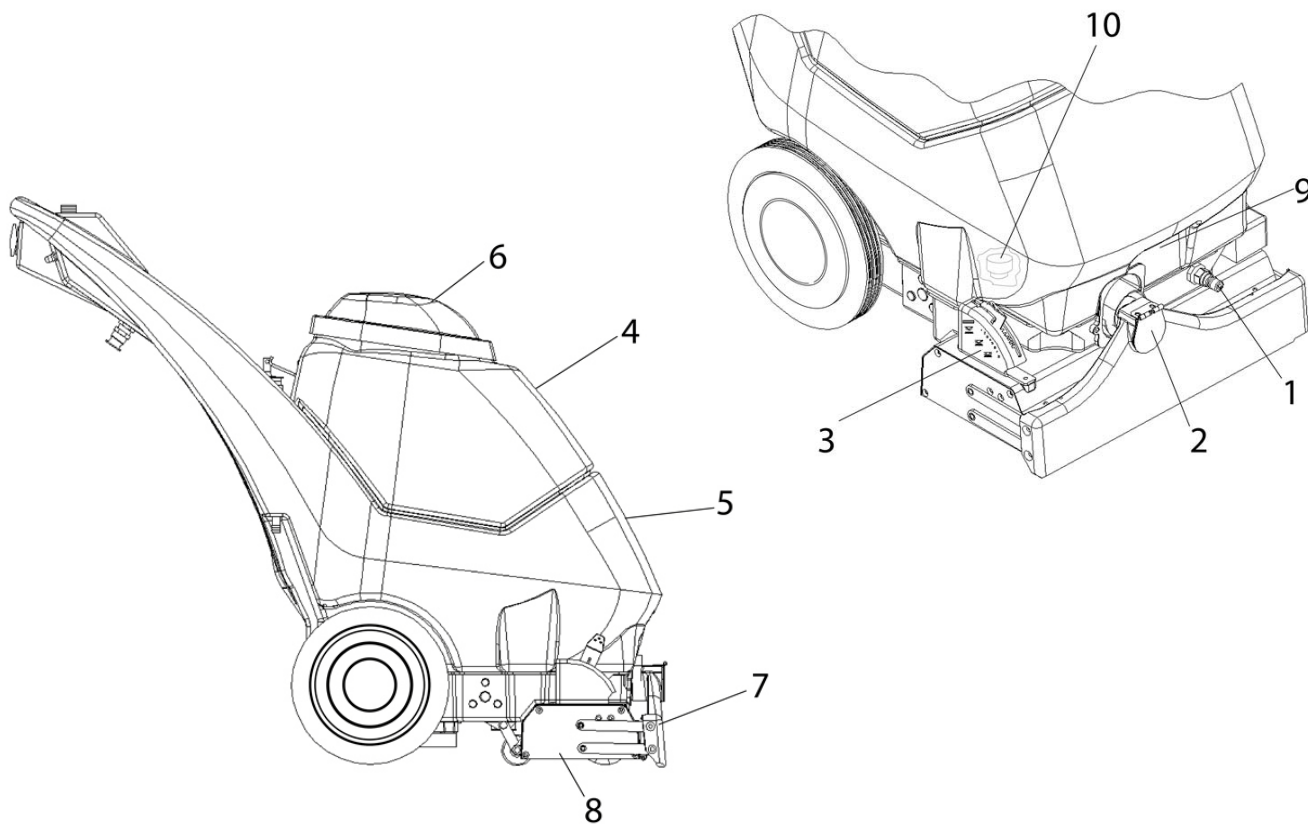

**Components - continued**

1. Solution Intake Cover.
2. Vacuum Intake Cover.
3. Float Shut-Off.
4. Clean-Out Opening.
5. Pour Spout.
6. Lift Handle.

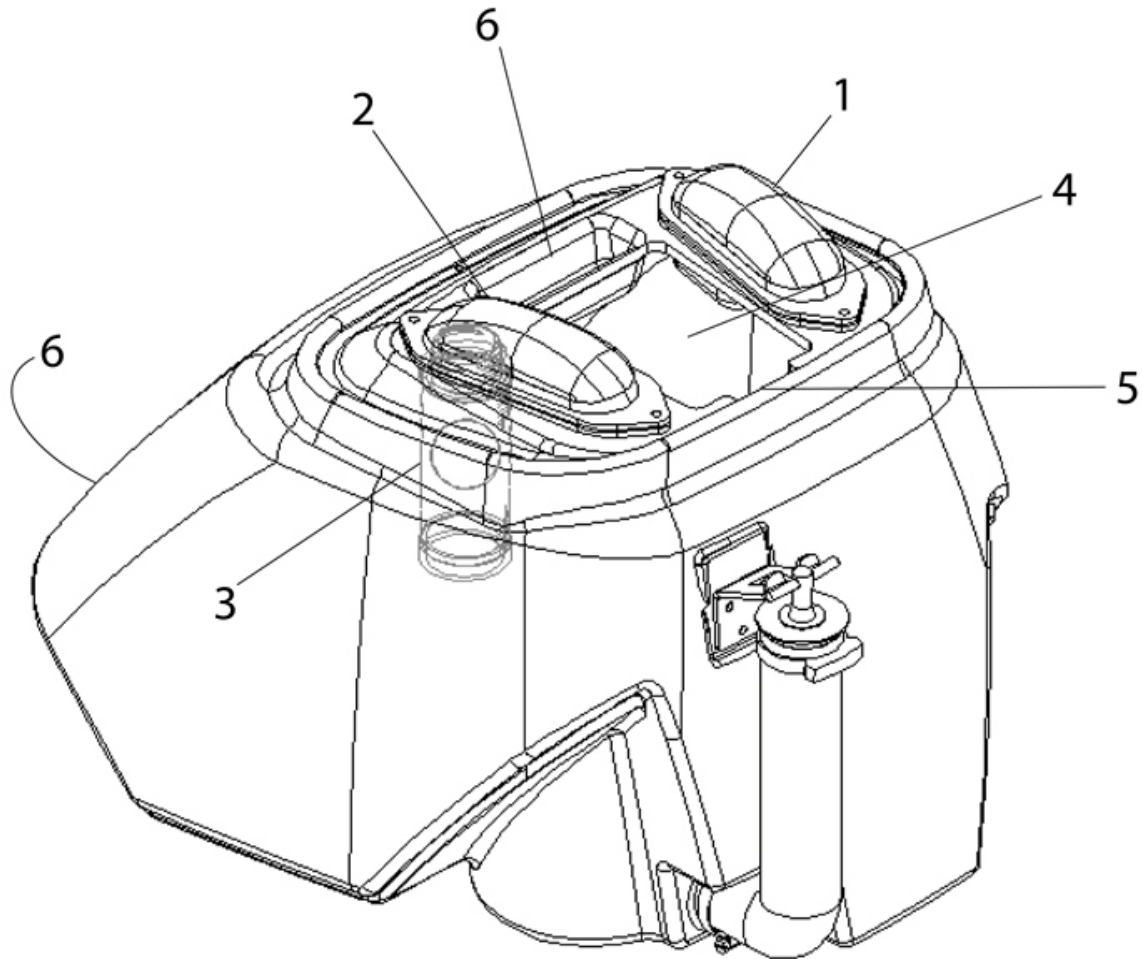



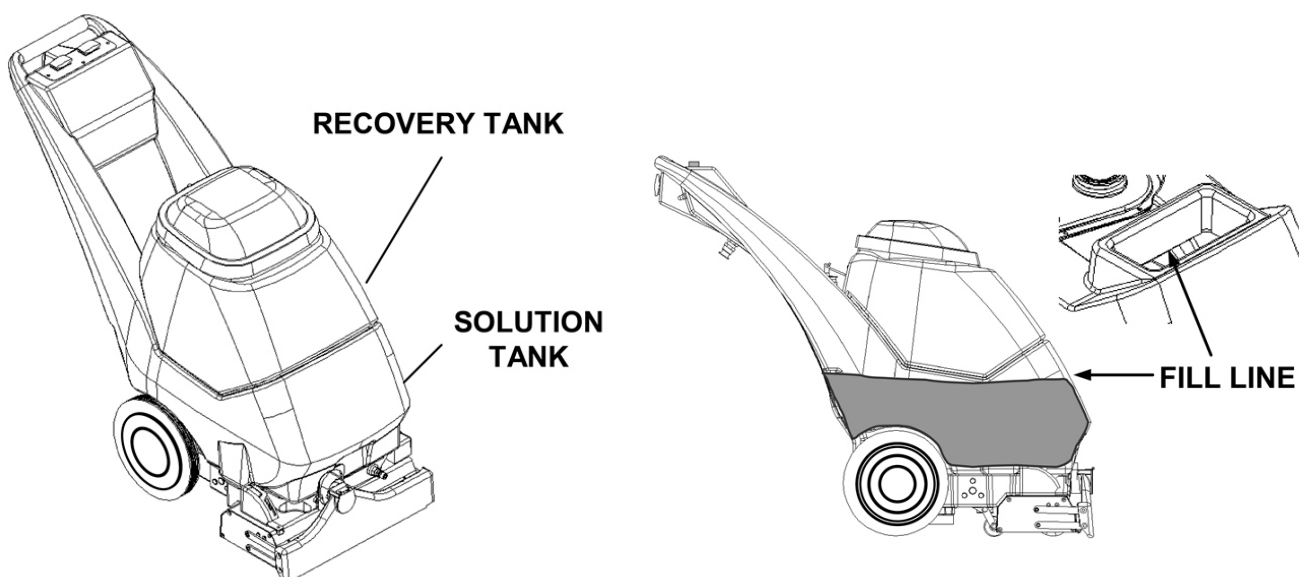

### Filling the EX7

*NOTE: Use clean bucket of water to fill solution tank.*

### **⚠ CAUTION:**

Do not put defoamer, solvents, spotter or prespray chemicals in the solution tank. Do not allow water to spill into vacuum motor inlet. Dry spillage from top of solution tank before replacing recovery tank.

### **⚠ ATTENTION:**

Ne pas mettre d'antimousse, de solvants, de détacheur ou de produits chimiques de prépulvérisation dans le réservoir à solution. Ne pas laisser l'eau se déverser dans l'entrée du moteur de l'aspirateur. Essuyer tout écoulement dans le haut du réservoir à solution avant de remettre le réservoir de récupération en place.

Suitable Chemicals	Non-Compatible Chemicals
Alkalis	Aldehydes
Detergents	Aromatic Hydrocarbons
Hydroxides	SP Butyls
Soaps	Carbon Tetrachloride
Vinegar	Clorox*
	Chlorinated Bleaches
	Chlorinated Hydrocarbons
	Lysol*
	Methyl Ethel Ketone (MEK)
	Perchorethylene (perc)
	Phenolics
	Trichlorethylene
	D-Limonene

\*Product Trademark Names

### Filling the EX7 - continued

1. Remove literature from recovery tank.

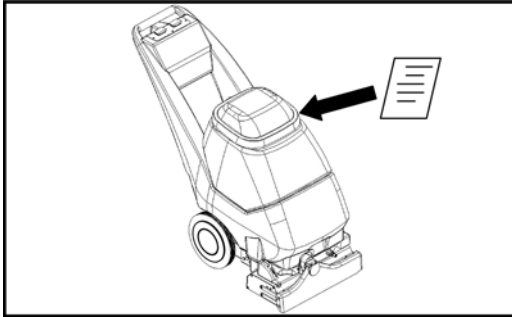

2. Remove the recovery tank from the machine.

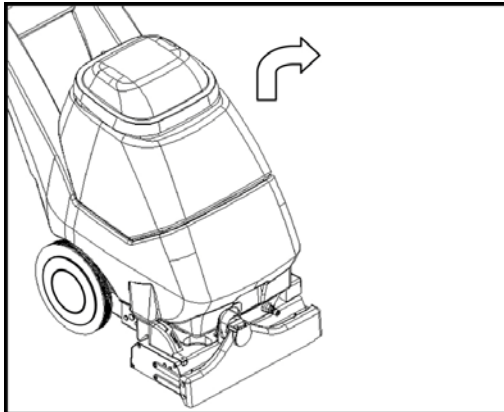

3. Fill the Solution Tank with 7 gallons (26.5 ltr.) of water, that is no more than 140°F/60°C.

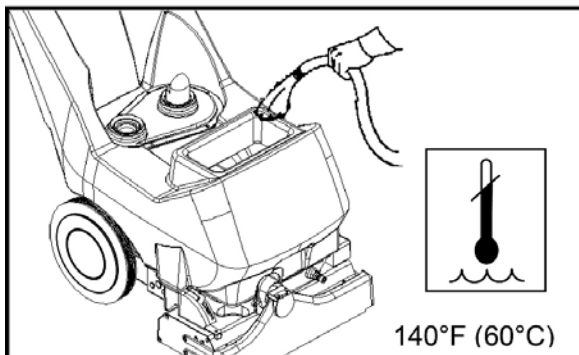

4. Add 7oz-14 oz. (207ml-414ml) of cleaning chemical.

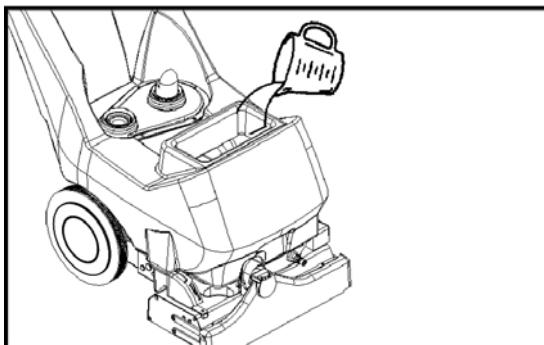

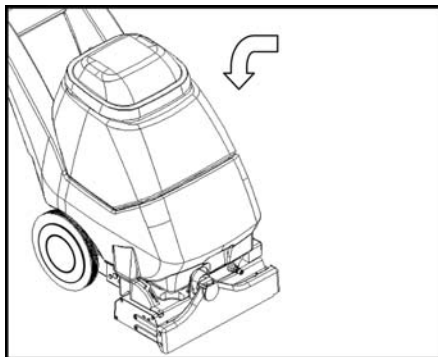

5. Replace the Recovery Tank on the machine.

### Machine Operation

1. Plug cord into grounded outlet.

*NOTE: Be sure dome is seated on recovery tank, and float shut-off is installed correctly.*

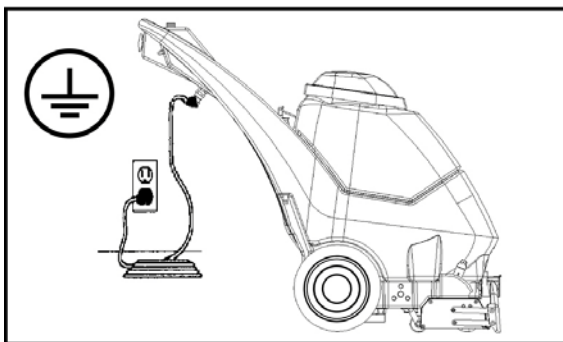

2. Adjust brush to proper setting.

*NOTE: For good operation the brush must skim the carpet. If circuit breaker trips, raise brush to prevent damage to motor or carpet.*

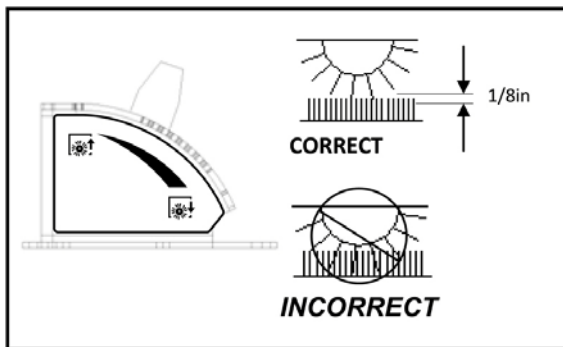

3. Turn on pump and vacuum motor switches ("ON"="I").

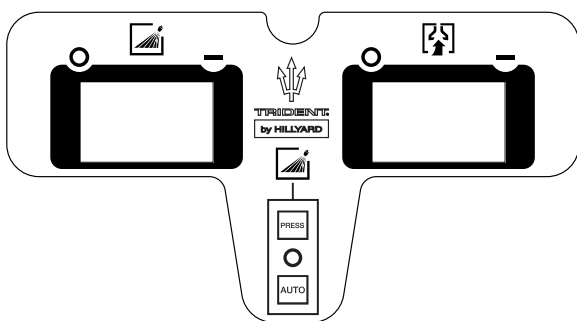

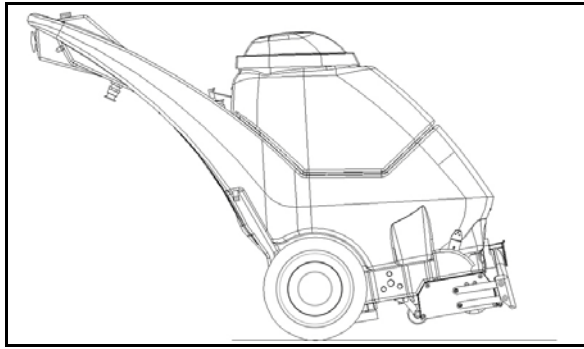

4. Tip machine back by main handle to move to starting point.

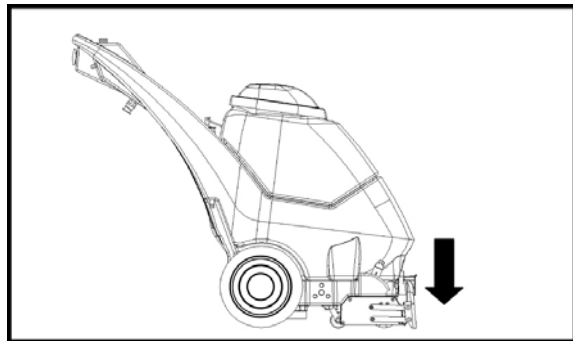

5. Lower machine to floor.

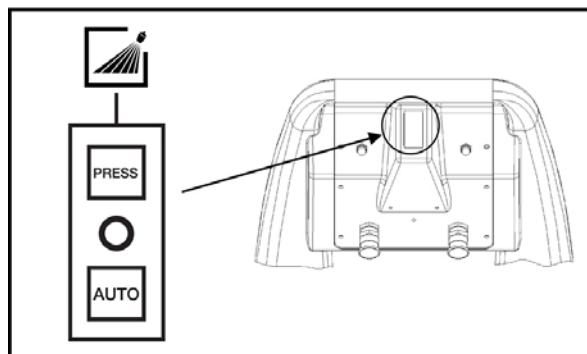

6. Select intermittent or continuous switch setting to turn on brush and start solution spray.  
The intermittent setting requires the operator to hold the switch in the "on" position with the thumb, and is typically used in small areas where short cleaning passes are made.  
The continuous setting allows the operator to set the switch in the "on" position with one touch, and is typically used in large areas where long cleaning passes are made.

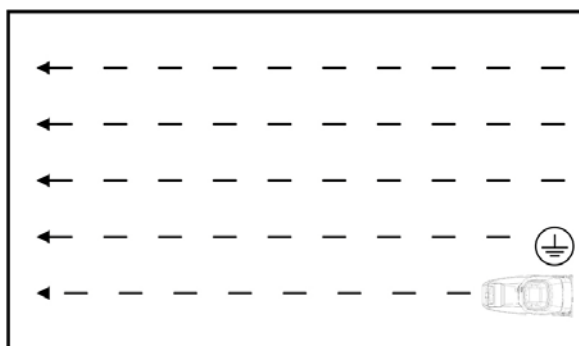

### Cleaning Procedure

1. Start at wall closest to power outlet. Pull straight back without pushing down on handle.

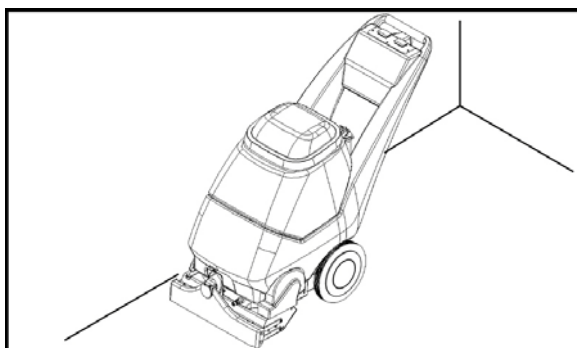
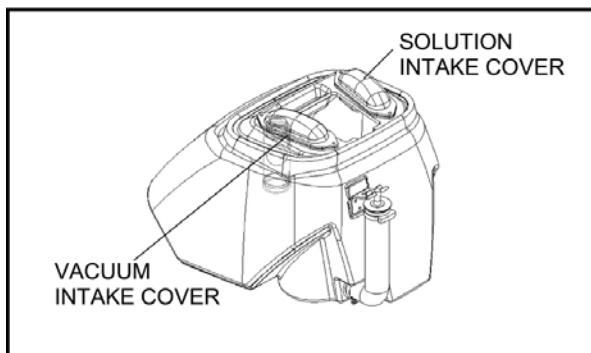
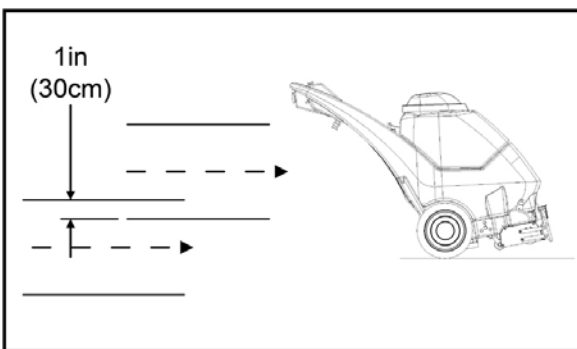
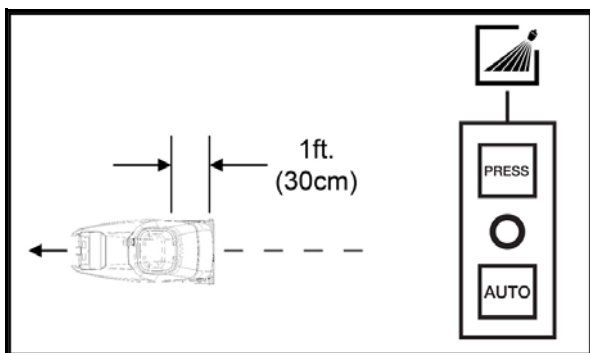

2. Release intermittent trigger switch or turn off continuous setting on solution switch approximately 1 foot before ending cleaning pass.

3. Push down on handle to raise vacuum shoe and brush before moving to the next cleaning pass. Overlap brush contact area a minimum of 1 inch.

4. During operation, observe the following: The EX7 is equipped with clear internal covers to facilitate operator viewing of dirty solution and vacuum air flow. During operation, observe the vacuum intake cover. Large amounts of water or foam entering the vacuum system can damage the vacuum motor.

*NOTE: If you notice either condition, shut down the machine immediately.*

Empty recovery tank and/or add defoamer to recovery tank.

5. Use right side of machine for cleaning against walls.

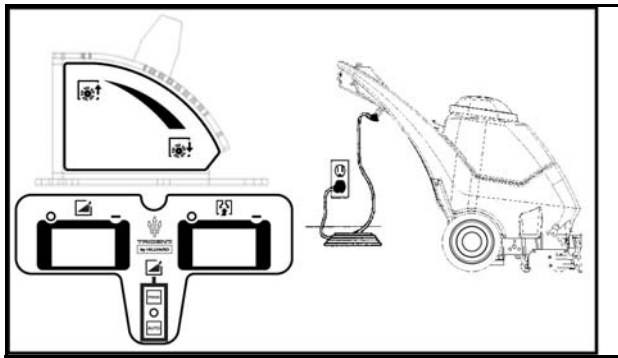

6. After cleaning, turn off all controls, return brush to storage position and carefully unplug machine.

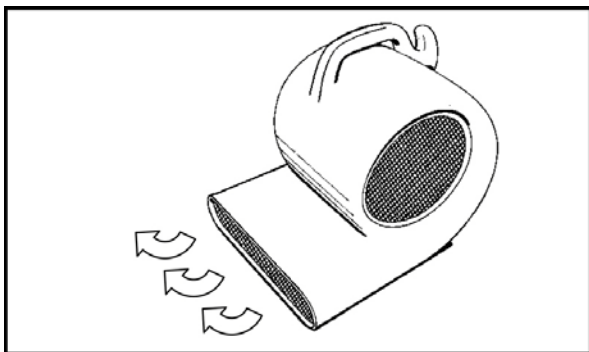

7. To speed drying, use an air moving fan.

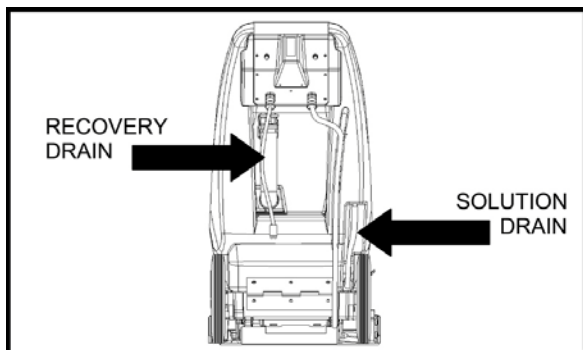

8. Empty recovery tank by releasing dump hose. Use a hose with cold water to clean out the recovery tank. Drain solution tank after each use.

## Accessory Tool Usage

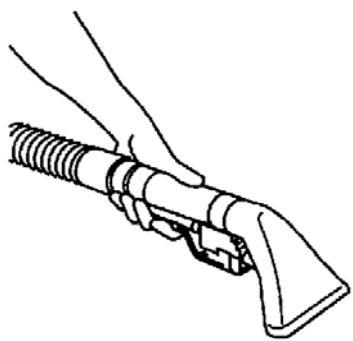
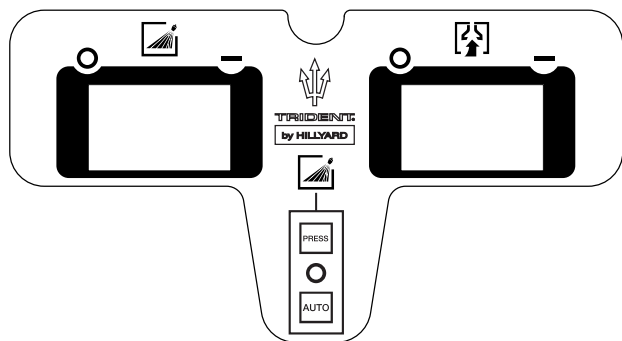
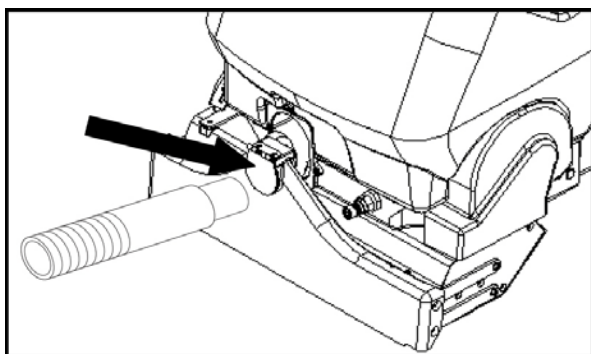
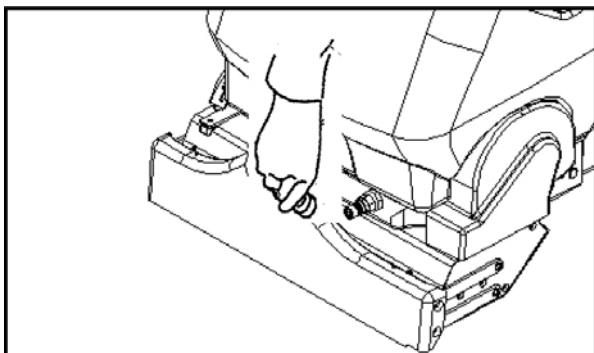

Use only one of the following acceptable accessory tools.

- 8.600-061.0 - STANDARD WAND
- 8.600-006.0 - VSM DUSTING TOOL W/MTG CLIP
- 8.603-154.0 - HOSE ASM, CST HANDTOOL U19821

1. Pull back collar and insert over machine mounted fitting, then release collar to lock into place.

2. Lift door on front of vacuum shoe and insert 1 ½ inch hose cuff into hole.

3. Turn on vacuum motor switch and set solution switch to intermittent position.

*NOTE: Be sure brush switch is in off position and brush is in storage position.*

4. Squeeze handle on accessory tool to begin cleaning.

**Service Schedule**

Maintenance	Daily	Weekly	Quarterly
Check machine for cord damage.	*		
Check recovery dome and gasket for damage and cleanliness.	*		
Check brush - should be clean with no lint or strings attached.	*		
Inspect vacuum shoe for blockage; remove fibers with coat hanger, etc.	*		
Check hoses for wear, blockages, or damage.	*		
Check handles, switches, and knobs for damage.	*		
Check vacuum motor intake filter and clean.	*		
Run one gallon of water through system.	*		
Clean out recovery tank and check float valve to make sure it moves freely.	*		
Clean out solution tank and remove and clean vacuum intake screen.	*		
Clean outside of all tanks and check for damage.	*		
Run vacuum motor for at least one minute to allow motor to dry.	*		
Store with dome off tank to allow the tank to dry.	*		
Check all bearings for noise		*	
Check all gaskets for wear and leakage		*	
Check vacuum intake screen for damage; replace if necessary.		*	
Check pump pressure; observe spray pattern and check with gauge if necessary		*	
Check and clean solution screen.		*	
Check belts for wear and replace as necessary.		*	
Check brush for wear; ensure bristles are not damaged.		*	
Check cables for fraying.		*	
Check the spray bar (manifold) for damage; replace if broken or bent.		*	
Check condition of vacuum shoe and frame for damage.		*	
Check overall performance of machine.		*	
Check vacuum motor carbon brushes.			*



## Periodic Maintenance

Twice a month, flush a white vinegar solution (One quart vinegar to two gallons of water) or anti-browning solution (mixed as directed) through the extractor. This will prevent build-up of alkaline residue in the system. If spray jets become clogged, remove the spray tips, wash them thoroughly, and blow-dry.

*NOTE: Do not use pins, wire, etc. to clean nozzles as this could destroy spray pattern.*

Periodically inspect all hoses, electrical cables and connections on your machine. Frayed or cracked hoses should be repaired or replaced to eliminate vacuum or solution pressure loss. If the cable insulation is broken or frayed, repair or replace it immediately. Don't take chances with electrical fire or shock.

## Daily / Regular Maintenance

Before making any adjustments or repairs to the machine, disconnect the power cord from electrical source.

1. Empty unused cleaning solution from the solution tank.
2. Inspect and clean filter screen in solution tank.
3. Flush pumping system with 4 or 7 liters of clean, hot water.
4. After each use, rinse tank with fresh water. Periodically inspect the recovery tank and decontaminate if necessary, using a Hospital Grade Virucide or a 1-10 bleach to water solution. Waste water should be disposed of properly.
5. Check for and remove any lint or debris around vacuum shoe.
6. Check spray jets for full spray pattern.
7. Remove lint and dirt build-up from brush and housing.

*NOTE: Brush removal.*

- a. To remove brush, grab and pull brush out from end opposite drive belt (operator's right). Remove other end from brush driver.
  - b. To install brush, line up slots in brush core with pin in driver on drive belt side (operator's left) and push brush onto driver. Then snap bearing end (opposite end) of brush into retaining clip.
8. Check cooling air screen (located on frame behind left wheel) for lint or debris.

9. Check float and shut-off screen and clean as necessary.

*NOTE: Always store machine with brush in "Store" position.*

## Vacuum Motor Replacement

### **⚠ WARNING:**

Only qualified maintenance personnel are to perform the following repairs.

### **⚠ AVERTISSEMENT:**

Seul le personnel d'entretien qualifié peut effectuer des réparations

1. Turn off all switches and unplug machine.
2. Remove recovery tank.
3. Remove the (2) screws that fasten the solution tank to the frame, and tilt tank back to expose the inside of the frame.
4. Locate the vacuum motor wires and disconnect at the connector. Close the solution tank.
5. Remove the (6) screws holding the vacuum motor cover to the solution tank.
6. Remove the vacuum motor.
7. Reverse process to install vacuum motor.

#### Vacuum Motor Carbon Brushes Replacement

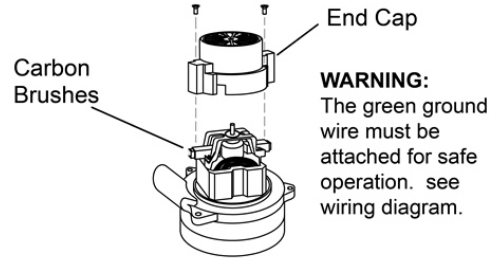

If armature commutator is grooved, extremely pitted or not concentric, the motor will need to be replaced or sent to a qualified service center.

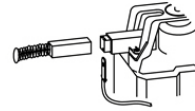

#### **Important:**

These brushes wear quicker as the length shortens due to increased heat. Spring inside brush housing will damage motor if brushes are allowed to wear away completely.

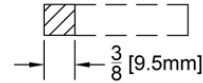

Periodically check the length of the carbon brushes. Replace both carbon brushes when either is less than 3/8" (9.5mm) long.

## Belt Replacement

### **⚠ WARNING:**

Only qualified maintenance personnel are to perform the following repairs.

### **⚠ AVERTISSEMENT:**

Seul le personnel d'entretien qualifié peut effectuer des réparations

1. Turn off all switches and unplug machine.
2. Remove recovery tank and brush.
3. Remove the (2) screws that fasten the solution tank to the frame, and tilt tank back to expose the inside of the frame.
4. Loosen the (4) screws that hold the brush motor in place and slide motor forward to release tension in belt.
5. Remove the (2) screws that fasten the vacuum shoe links to the brush housing.
6. Remove the (3) screws that fasten the side plate to the brush housing to remove belt.

*NOTE: All components associated with driving the brush will come out with the side plate.*

7. Reverse process to install belt.

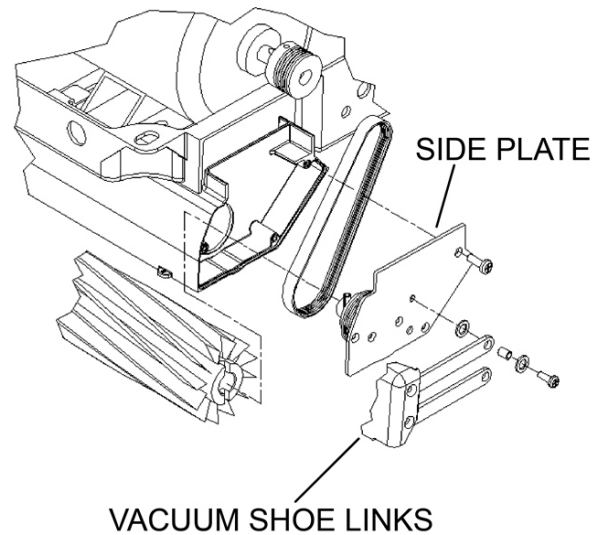

## Solution Pump Replacement

### **⚠ WARNING:**

Only qualified maintenance personnel are to perform the following repairs.

### **⚠ AVERTISSEMENT:**

Seul le personnel d'entretien qualifié peut effectuer des réparations

1. Turn off all switches and unplug the machine.
2. Remove recovery tank.
3. Remove the (2) screws that fasten the solution tank to the frame, and tilt tank back to expose the inside of the frame.
4. Remove solution hoses from fittings in pump.
5. Remove the (2) screws that fasten the pump to the frame.
6. Reverse process to install pump.

## Troubleshooting Chart

PROBLEM	CAUSE	SOLUTION
No Power, Nothing Runs	Is the cord plugged in.	Plug in cord.
	Circuit breaker tripped in building.	Reset breaker.
	Faulty switch.	Call for service.
	Faulty power cord or pigtail.	Call for service.
Vacuum Motor Will Not Run	Vacuum circuit breaker tripped.	Reset breaker.
	Faulty main vacuum switch.	Call for service.
	Loose wiring.	Call for service.
	Faulty vac motor.	Call for service.
	Carbon brushes worn.	See "Brush Replacement" in maintenance section.
Vacuum Motor Runs But Suction Is Poor	Debris lodged in vac shoe.	Remove debris from vac shoe.
	Dome gasket defective or missing.	Replace as necessary.
	Vacuum hose cracked or hose cuff loose.	Replace or repair as necessary.
	Recovery tank full / float ball stuck in the up position.	Turn off vac motor. Drain and rinse recovery tank.
Poor Or No Water Flow (Carpet Is Streaky)	Main pump switch off.	Turn on.
	Jets clogged or missing.	Clean using a vinegar /water solution or replace.
	Solution filter clogged.	Drain solution tank and clean solution filter.
	Faulty solenoid.	Call for service.
Brush Does Not Spin	Brush switch off.	Turn on brush switch.
	Brush circuit breaker tripped.	Reset circuit breaker.
	Brush belt broken.	Replace as necessary.
	Faulty brush motor.	Call for service.