

# Inflatable Dock Slide Owner's Manual

#00002



[WWW.RAVESPORTS.COM](http://WWW.RAVESPORTS.COM)

**Copyright © 2018**

All rights reserved. No part of this publication may be reproduced or transmitted in any form or by any means, electronic or mechanical, including photocopy, recording, or any information storage and retrieval system, without permission in writing from the publisher. Requests should be mailed to RAVE Sports, 985 Aldrin Drive #301, Eagan MN, 55121

# Table of Contents

Introduction .....	2
Safety rules and information.....	3
Dock compatibility guide .....	5
Assembling your Dock Slide .....	6
Operation .....	10
Deflation .....	11
Cleaning and storage .....	12
Troubleshooting .....	12
Repairs.....	13

## Contents in this package

- Dock Slide Tube
- 2 Attachment Straps
- Electric (120 volt) Inflator/Deflator (#02704)
- Repair Kit

Please make sure you have received the contents listed, and then record the following information for future reference.

---

---

**Date Purchased:** \_\_\_\_\_

**Purchased from:** \_\_\_\_\_

## Introduction

Water sports can be safe and fun for all levels of enthusiasts. The Owner's Manual is presented to enhance your enjoyment of the sport. It is intended to alert you to some of the potentially dangerous conditions that can arise in all water sports.

Please take a few minutes to read this manual before assembling and using the product. Although the product is simple to use, this manual contains important safety information that you and all users must understand to safely enjoy the Dock Slide.

If you have any questions regarding this product, please call RAVE Sports at 1-800-659-0790, or visit [www.ravesports.com](http://www.ravesports.com). Please have the serial number (if available) from your product ready when you call.

# **WARNING**

**UNSAFE USE OF THE DOCK SLIDE CAN RESULT  
IN PERSONAL INJURY OR DEATH.**

To reduce the risk of injury, read and follow all instructions and warnings in this manual. Do not use this product unless you understand and accept the risk of injury involved with this activity.

## Safety Rules and Information

- Read and understand all of the information contained in this owner's manual before assembling and using your product.
- Make sure that everyone who uses the product is provided with and understands these safety rules and information. This product is not recommended for non-swimmers.
- The Dock Slide is designed to be used only on docks that allow for safe attachment. Ensure that straps are properly attached to the dock and securely tightened before using. Do not use if attachment straps are damaged or incorrectly attached.
- Choose a location for your product that is most protected from wind, of at least 6 feet water depth at slide location, and free of obstructions above and below the water for at least 20 feet to the front and sides of the Dock Slide. Dock should have at least 12 inches but not greater than 30 inches of clearance above water surface.
- Always wear a U.S. Coast Guard approved Type III (PFD) personal floatation device when using the product.
- Never use the product after sunset, before dawn, or any other time in poor lighting conditions.
- Never use the product in rough surface water conditions, during storms, or when there is lightning. If an unexpected storm arises while using the product, seek shelter on shore. Do not stay on the product.
- Never use the product under the influence of alcohol or drugs, which may impair balance and proper judgement.
- Always stay under control while using the product.
- Always make sure water near slide entry is clear of swimmers or other obstructions including dock posts, benches, and boat lifts.
- Never swim or play under the Dock Slide.
- This product is not a towable; do not tow behind a boat or other vehicle.

- Do not allow more than one person (up to 180 lbs.) to slide and/or climb on the slide at one time. Exceeding this may result in injury.
- Never dive headfirst down the Dock Slide or attempt other acrobatic maneuvers on the product. Always slide feet first.
- No pushing or shoving persons while on the Dock Slide.
- Do not climb up the Dock Slide to exit the water. Use boarding ladder on the dock.
- Never jump from top of Dock Slide and stay in a seated position at all times. Do not stand on, leap, or dive from the dock slide.
- Never use the product while tired or fatigued. Use extreme caution while swimming around the dock.
- Do not use Dock Slide in close proximity to moving boats or other water craft in operation.
- Always inspect the areas around and under the product before each use to ensure the water is deep enough and free of all rocks, logs, sand bars, and underwater obstructions and that the product is a safe distance from above water hard objects. Ask about local water conditions before using the product in unfamiliar water.
- When not in use, deflate Dock Slide and store in a secure area. Never leave slide inflated and unattended. Never drag your dock slide on the ground; always lift it to move it.
- Inspect your product for any worn, defective, or missing parts and replace or repair before using. Do not use if product is damaged, leaking air, or under-inflated.
- Use the Dock Slide only under mature, knowledgeable adult supervision.

## Dock Compatibility Guide

**IMPORTANT: FOR DOCK SLIDE USE ONLY.** DO NOT ATTEMPT TO USE ON DECKBOATS, RUNABOUTS, FISHING BOATS OR OTHER CRAFT. BEFORE ASSEMBLING OR USING YOUR SLIDE, MAKE SURE YOUR DOCK MEETS THE FOLLOWING CRITERIA:

1. A secure deck with a height of 12-30 inches from the top of dock deck to the top of the water below.
2. Water depth should be a minimum of 6 feet deep (72") at location where the slide will be mounted.
3. The Dock Slide should not be used with docks that have less than 12 inches or more than 30 inches of clearance between the water surface and the top of the dock or with less than the recommended water depth as indicated above.
4. 1/8" x 1 1/2" openings in the decking to allow attachment straps to be fed through.

These criteria must be met in order for the Dock Slide to be securely fastened to the dock. If your dock does not meet these criteria, do not attempt to use the product.

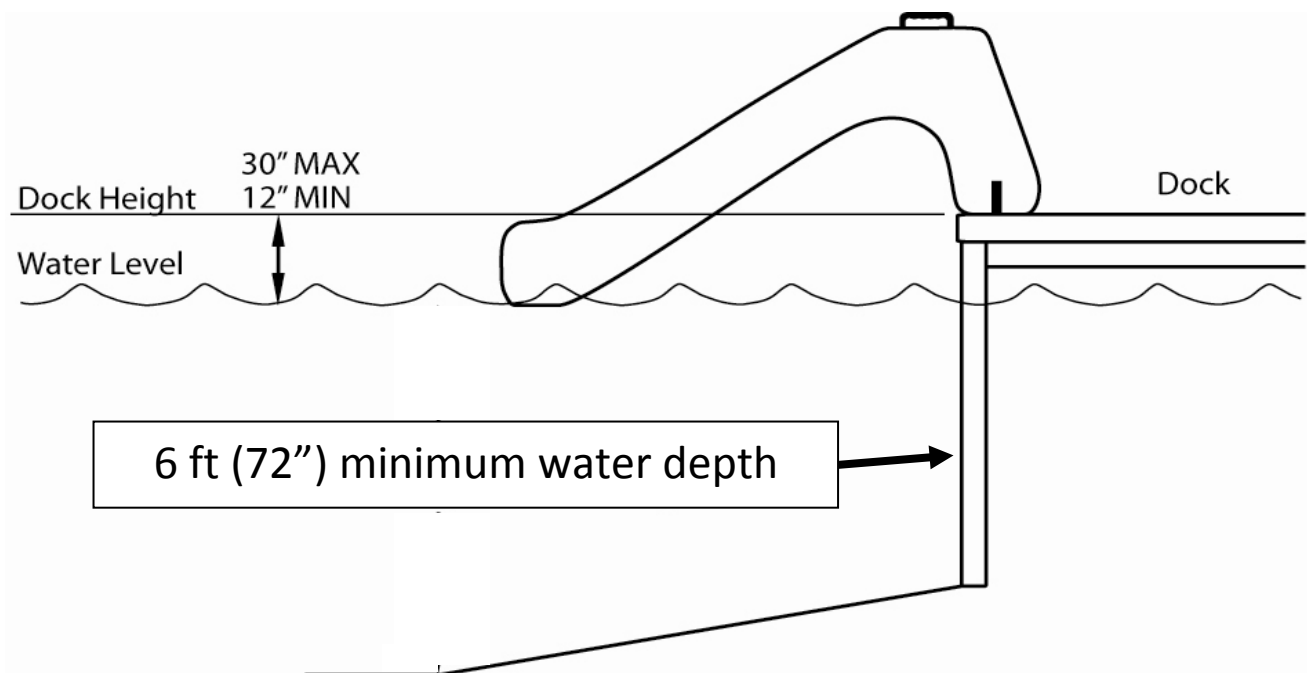

## Assembling your Dock Slide

### Step 1 – Confirm Dock Conditions

Make sure the dock deck and surrounding water are free from obstructions and that you have a minimum water depth as listed previously. Ensure the dock deck is secure and stable with a height between 12 - 30 inches above the water.

Do not use if your dock does not meet these requirements.



Place deflated Dock Slide on the shore or similar firm surface with sufficient clearance to inflate. Make sure the area is free of all sharp sticks, rocks or other objects which could puncture the product.

### Step 2 - Inflate

Using the RAVE Sports electric (120 volt) high-speed inflator / deflator (#02704) with a long reinforced hose and 5 inflation adapters that is included with the dock slide, inflate the main chamber of the dock slide until it is very firm (1.5 – 2.0 psi). A 0-15 psi Digital Pressure Gauge (Item # 02809) is available separately from RAVE Sports.

*CAUTION: Always use caution when using electricity near water. We recommend inflating your dock slide in an area on land a safe distance away from water, then lifting your dock slide to the dock.*

Locate the main valve (on climb side of slide) and remove cap. A special inflation adaptor is included with this product. Simply lock the adaptor onto the end of the inflation hose and insert into the valve body. Turn  $\frac{1}{4}$  turn clockwise to lock in place.



**NOTE:** This inflation adaptor will automatically open the valve when inserted and will close the valve when removed. You do not need to manually open/close the valve when using this special adaptor.

Inflate the main chamber of the slide until it is firm. Properly inflated, the slide will be firm and will not buckle during use. Inflate both side rail tubes last.

To remove inflator, turn adaptor  $\frac{1}{4}$  turn counter-clockwise. Install outer cap.

*CAUTION: Do not over-inflate. Do not exceed 2 PSI if filling with compressed air. Excessive pressure can cause the tube to rupture with potentially damaging force to eyes, ears, skin and limbs. Use of an air compressor or over-inflation can rupture the tube beyond repair, thus voiding the warranty.*



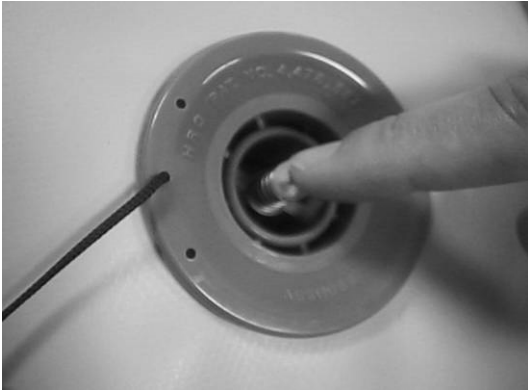

To manually open valve, depress the stem and rotate clockwise. To close valve, depress the stem and rotate counter-clockwise.

**NOTE:** It is normal for air pressure within the tube to fluctuate depending on air and water temperatures. It may be necessary to increase or decrease the air pressure in your product accordingly. To avoid damage on extremely hot days it may be necessary to check and release the air pressure from your product throughout the day. On cool days you may need to add air.



**Step 3 – Carry (do not drag) slide to dock and attach straps to dock**

Attach the 48-inch, black attachment straps by looping the strap around the planks of your dock.

**IMPORTANT:** Your decking must have openings that are a minimum of 1/8" x 1 1/2" wide to accommodate the straps passing through.

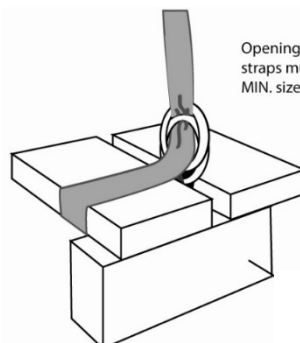

Openings for attachment straps must be 1/8" x 1 1/2" MIN. size.

For planks that run perpendicular to the slide direction (Fig. A), insert the straps around the second or third plank. Space straps approximately 36" apart.

For planks that run parallel to the slide direction (Fig. B), insert the straps behind a frame support member that is running perpendicular to the decking. This is critical to prevent the straps and slide from slipping forward.

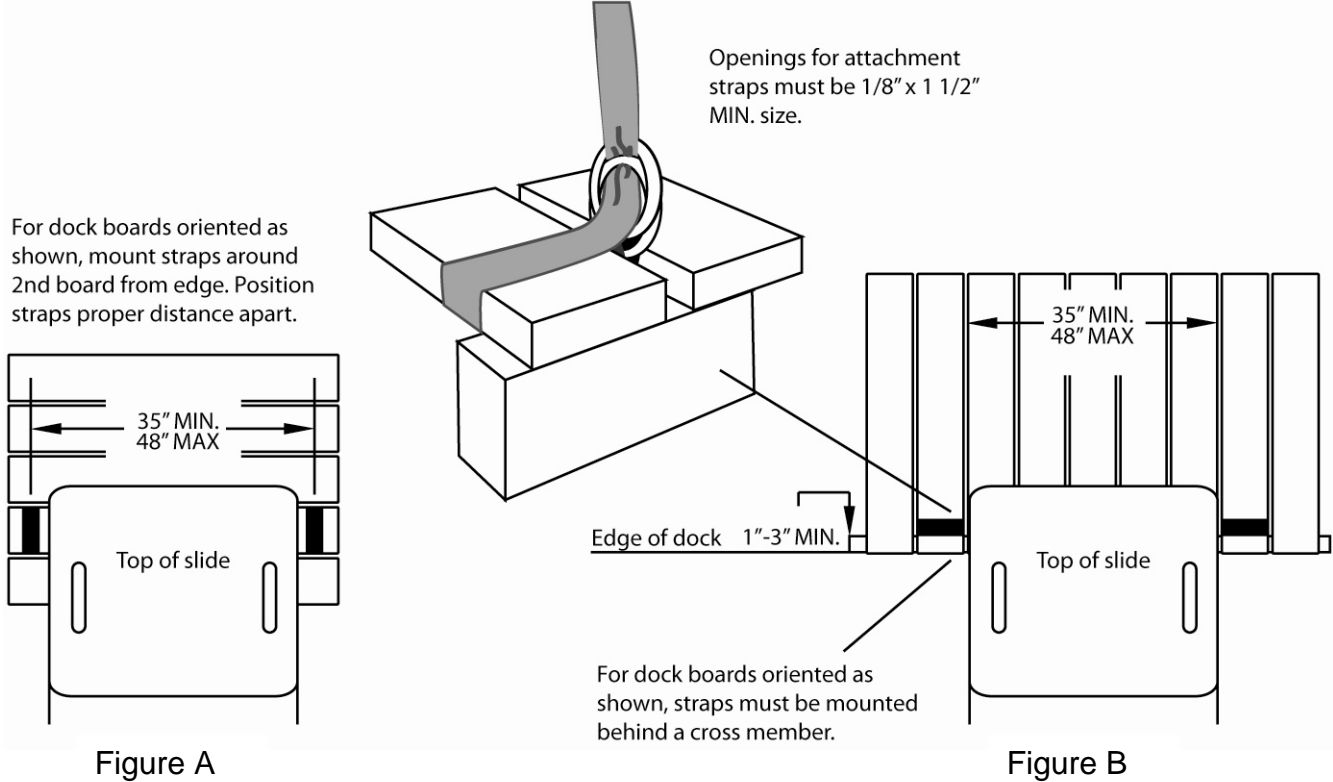

Attach both straps to the dock and tighten securely.

## Step 4 – Buckle straps to Dock Slide



Place a piece of foam or other non-slip mat (not included) on the surface of the deck where the slide will be positioned. This will help protect the inflatable slide from wear and possible puncture.

Position the slide between the two straps. Attach the free end of both straps to the buckle on each side of the slide. Feed the strap through the backside (slide side) of the buckle jaw and pull snug. Pull both straps tight so the slide is securely fastened to the surface of the dock. Tie off the remaining loose end of both straps in a secure fashion.

Before sliding, check to make sure the slide is securely fastened to the dock and the decking will not lift during use. Secure decking if necessary.

## Operation

Before sliding, wet slide surface with water. Sliding on a dry surface can cause burns to the skin or lack of sliding movement.

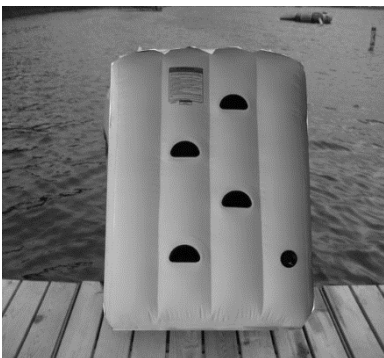

Climb up slide using hand and foot holds. Use top handles when transitioning from the climbing position to a seated position. **NEVER STAND ON THE TOP OF THE SLIDE.** Always slide feet first. Ensure water is clear of obstructions and other people before going down slide.

# Deflating your Dock Slide

## Step 1

Loosen all connection straps from dock deck.

## Step 2

Lift dock slide and carry it to an area on land safely away from water. Locate the main valve (on climb side of slide) and remove cap. Using the electric (120 volt) high speed inflator / deflator included with your dock slide, and the special inflation adaptor also included with this product, simply lock the adaptor onto the end of the inflation hose and insert into the valve body. Turn ¼ turn clockwise to lock in place. Set pump on “deflate” option, turn on, and deflate completely.



For deflation:

- 1) Deflate both side rails first
- 2) Deflate main slide second

Once all air is removed, make sure slide is completely dry for storage. Fold or roll to a compact size.

## Cleaning and Storage

- When the inflatable product is not being used, store it in a covered, shaded area. This will help protect it against ultraviolet (UV) rays and extend the life of the product.
- Clean the inflatable completely with a mild soap and fresh water. **NEVER USE PETROLEUM BASED PRODUCTS OR SOLVENTS FOR CLEANING. NEVER USE A POWER WASHER SINCE THE HIGH PRESSURE WATER WILL DAMAGE THE TUBE BEYOND REPAIR.**
- For storage, roll the product loosely and place in a container, preferably one that rodents can't chew through.
- Secure against unauthorized and unsupervised use.
- Store in a cool, dry location. Do not store product directly on concrete surface. Place mothballs around stored inflatable to keep mice and insects away.

## Troubleshooting

Air chambers won't hold air:

- Check to make sure all valves are completely closed.
- Check for holes in the slide following the procedures in the "Repairs" section.

## Repairs

Additional repair patches can be purchased at [www.ravesports.com](http://www.ravesports.com)

For Minor Holes or Tears:

- Inflate the slide and locate the leak by spraying the tube with soapy water. Bubbles will appear where there is a leak.
- Determine the hole size and cut a circular patch  $\frac{1}{2}$  - 1 inch wider than the hole with repair kit included with the product.
- Remove air from the tube and dry tube completely where the patch is to be applied.
- Peel off paper back from patch, apply repair patch to area and work out any air bubbles from beneath the patch.
- Apply weight to the patched area for one hour before re-inflating.

**For warranty and return information, please visit [www.ravesports.com](http://www.ravesports.com).**

RAVE

S P O R T S®

RAVE

S P O R T S®

**THIS PAGE INTENTIONALLY LEFT BLANK.**

RAVE

S P O R T S®

RAVE

S P O R T S®



[WWW.RAVESPORTS.COM](http://WWW.RAVESPORTS.COM)

**RAVE SPORTS**

A Revel Match, LLC Company

**985 Aldrin Drive #301**

**Eagan MN, 55121**

**800.659.0790**

January 2018