

Invacare® **G5510 Bed**
Full Electric Bed

User Manual

EN

IMPORTANT SAFETY INSTRUCTIONS
SAVE THESE INSTRUCTIONS

For more information regarding bed rail safety, refer to the Bed Rail Entrapment Risk Notification Guide at www.invacare.com.

This manual **MUST** be given to the user of the product.

BEFORE using this product, read this manual and save for future reference. If you are unable to understand the warnings, cautions or instructions, contact a healthcare professional, dealer or technical personnel before attempting to use this equipment



Yes, you can.®

Updated versions of this manual are available at www.invacare.com

© 2018 Invacare Corporation. All rights reserved. Reproduction, duplication or modification in whole or in part is prohibited without prior written permission from Invacare. Trademarks are identified by ™ and ®. All trademarks are owned by or licensed to Invacare Corporation or its subsidiaries unless otherwise noted.

Making Life's Experiences Possible is a registered trademark in the U.S.A.

Sherwin-Williams is a registered trademark of The Sherwin-Williams Company.

1	GENERAL	5
	Symbols	5
	Symbols Used on Bed	6
	Symbols Used on Packaging.....	7
	Limited Warranty	8
2	OVERVIEW	9
	Label Locations.....	9
	Specifications.....	11
	Accessories and Accessory Weight	13
	Optional Touch-up Paint.....	14
3	SAFETY	15
	General Guidelines	15
4	EMC INFORMATION	31
	Electromagnetic Compatibility (EMC) Information	31
5	OPERATION	33
	Operation Verification.....	35
	Operating the Bed	36
	Operating the Locking Function on the Locking Caster	38
	Electrical Connections	38
	Installing/Removing Pendant and/or Port Cover	39
	Using the Emergency Crank.....	41
	Optional Bed Rails	42
6	DEALER SECTION - PACKAGING, HANDLING, AND SET-UP	43

CONTENTS

Unpacking and Handling	43
Inspecting	45
Set-Up	45
Assembling the Bed Ends	49
Electrical Connections	54
Installing/Removing Mattress Keepers	55
Positioning Mattress Stop for SPS1080 Mattress and SPS1084 Mattress	56
Connect Power Supply	58
Storing the Bed	58
7 TROUBLESHOOTING/MAINTENANCE - USER/DEALER	60
<hr/>	
Troubleshooting Electrical	60
Troubleshooting Mechanical	62
8 MAINTENANCE AND CLEANING	64
<hr/>	
Maintenance Checklist	64
Cleaning the Beds	65

I General

I.1 Symbols

Warnings

Signal words are used in this manual and apply to hazards or unsafe practices which could result in personal injury or property damage. See the information below for definitions of the signal words.



DANGER!

Danger indicates an imminently hazardous situation which, if not avoided, will result in death or serious injury.



WARNING!

Warning indicates a potentially hazardous situation which, if not avoided, could result in death or serious injury.



CAUTION!

Caution indicates a potentially hazardous situation which, if not avoided, may result in property damage or minor injury or both.



IMPORTANT!





Indicates a hazardous situation that could result in damage to property if it is not avoided.













Gives useful tips, recommendations and information for efficient, trouble-free use.





I GENERAL

I.2 Symbols Used on Bed

	General Warning Symbol (ISO 7010 - W001)
IP66	International Protection Code. Degree of protection against solid foreign objects and ingress of water.
	Explosive Material, explosion hazard symbol (ISO 7010 - W002)
	Safe Working Load The combined weight of the patient, visitors, mattress, bedding and all accessories MUST not exceed rated capacity of safe working load.
	Intertek's ETL Listed Mark for US. A product bearing the ETL Listed Mark is determined to have met the minimum requirements of prescribed product safety standards.

	Flammable Material Symbol (ISO 7010 - W021)
	READ and Understand the User Manual before using the bed. (ISO 7010 - M002)
	General Mandatory Action Symbol (ISO 7010 - M001)
	Maximum Patient Weight
	General Prohibition Symbol (ISO 7010 - P001)

	EIP Pollution Control Mark (China RoHS)
	WEEE Directive 2002/96/EC
	UL Recognized Component in U.S. and Canada
	EC Directive Compliant
	C - Tick (Australian EMC)

	Degree of protection against electrical shock. Type BF equipment.
	Type of protection against electrical shock. Class II, Double Insulation.
	Alternating Current
	Protective Conductor Terminal
	IEC 60417 - 5957 For Indoor Use Only

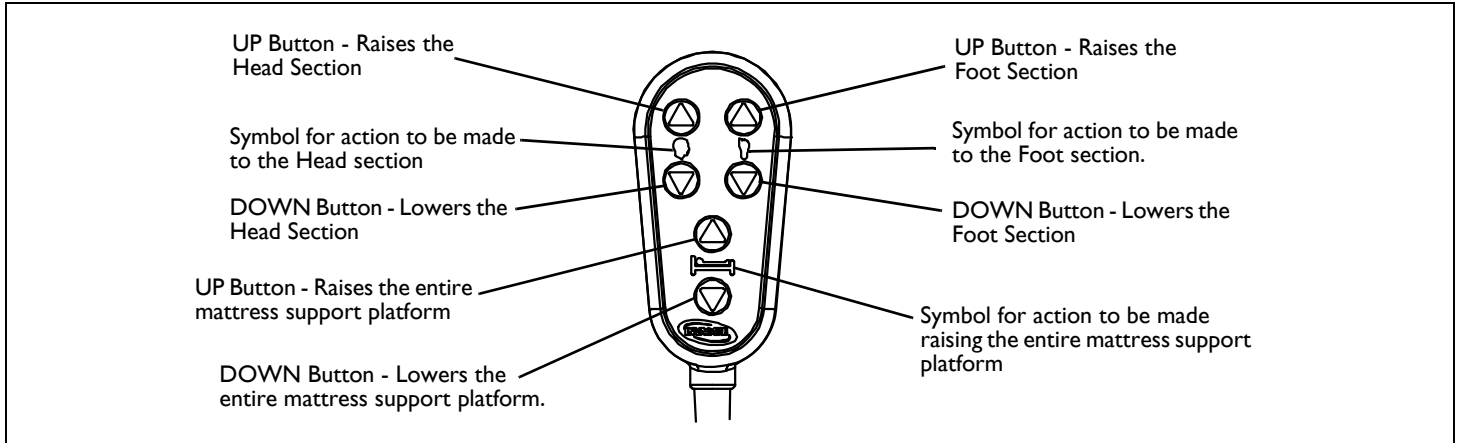

I.3 Symbols Used on Packaging



ISO 7000 - 0623
TOP



ISO 7000 - 0621
FRAGILE



ISO 7000 - 0626
KEEP DRY



ISO 7000 - 2403
DO NOT STACK OVER
2 HIGH



ISO 7000 - 0632
PERMITTED
TEMPERATURE
RANGE

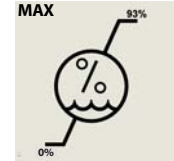

ISO 7000 - 2620
PERMITTED
HUMIDITY AREA

I GENERAL

I.4 Limited Warranty

PLEASE NOTE: THE WARRANTY BELOW HAS BEEN DRAFTED TO COMPLY WITH FEDERAL LAW APPLICABLE TO PRODUCTS MANUFACTURED AFTER JULY 4, 1975.

This warranty is extended only to the original purchaser who purchases this product when new and unused from Invacare or a dealer. This warranty is not extended to any other person or entity and is not transferable or assignable to any subsequent purchaser or owner. Coverage under this warranty will end upon any such subsequent sale or other transfer of title to any other person.

This warranty gives you specific legal rights and you may also have other legal rights which vary from state to state.

Invacare warrants the mechanical and electrical components of this product when purchased new and unused to be free from defects in materials and workmanship for a period of two years from date of purchase from Invacare or a dealer, with a copy of the seller's invoice required for coverage under this warranty. Invacare warrants all welds of this product when purchased new and unused to be free from defects in materials and workmanship for a period of five years from date of purchase from Invacare or a dealer, with a copy of the seller's invoice required for coverage under this warranty. If within such warranty period any such product shall be proven to be defective, such product shall be repaired or replaced, at Invacare's option, with refurbished or new parts. This warranty does not include any labor or shipping charges incurred in replacement part installation or repair of any such product. Product repairs shall not extend this warranty - coverage for repaired product shall end when this limited warranty terminates. Invacare's sole obligation and your exclusive remedy under this warranty shall be limited to such repair and/or replacement.

For warranty service, please contact the dealer from whom you purchased your Invacare product. In the event you do not receive satisfactory warranty service, please write directly to Invacare at the address on the back cover, provide dealer's name, address, and the date of purchase, indicate nature of the defect and, if the product is serialized, indicate the serial number. Do not return products to our factory without our prior consent.

LIMITATIONS AND EXCLUSIONS: THE FOREGOING WARRANTY SHALL NOT APPLY TO SERIAL NUMBERED PRODUCTS IF THE SERIAL NUMBER HAS BEEN REMOVED OR DEFACED, PRODUCTS SUBJECTED TO NEGLIGENCE, ACCIDENT, IMPROPER OPERATION, MAINTENANCE OR STORAGE, PRODUCTS MODIFIED WITHOUT INVACARE'S EXPRESS WRITTEN CONSENT (INCLUDING, BUT NOT LIMITED TO, MODIFICATION THROUGH THE USE OF UNAUTHORIZED PARTS OR ATTACHMENTS; PRODUCTS DAMAGED BY REASON OF REPAIRS MADE TO ANY COMPONENT WITHOUT THE SPECIFIC CONSENT OF INVACARE, OR TO A PRODUCT DAMAGED BY CIRCUMSTANCES BEYOND INVACARE'S CONTROL, AND SUCH EVALUATION WILL BE SOLELY DETERMINED BY INVACARE. THE WARRANTY SHALL NOT APPLY TO NORMAL WEAR AND TEAR OR FAILURE TO ADHERE TO THE PRODUCT INSTRUCTIONS.

THE FOREGOING EXPRESS WARRANTY IS EXCLUSIVE AND IN LIEU OF ANY OTHER WARRANTIES WHATSOEVER, WHETHER EXPRESS OR IMPLIED, INCLUDING THE IMPLIED WARRANTIES OF MERCHANTABILITY AND FITNESS FOR A PARTICULAR PURPOSE, AND THE SOLE REMEDY FOR VIOLATIONS OF ANY WARRANTY WHATSOEVER, SHALL BE LIMITED TO REPAIR OR REPLACEMENT OF THE DEFECTIVE PRODUCT PURSUANT TO THE TERMS CONTAINED HEREIN. THE APPLICATION OF ANY IMPLIED WARRANTY WHATSOEVER SHALL NOT EXTEND BEYOND THE DURATION OF THE EXPRESS WARRANTY PROVIDED HEREIN. INVACARE SHALL NOT BE LIABLE FOR ANY CONSEQUENTIAL OR INCIDENTAL DAMAGES WHATSOEVER.

SOME STATES DO NOT ALLOW THE EXCLUSION OR LIMITATION OF INCIDENTAL OR CONSEQUENTIAL DAMAGE, OR LIMITATION OF HOW LONG AN IMPLIED WARRANTY LASTS, SO THE ABOVE EXCLUSION AND LIMITATION MAY NOT BE APPLICABLE.

THIS WARRANTY SHALL BE EXTENDED TO COMPLY WITH STATE/PROVINCIAL LAWS AND REQUIREMENTS.

2 Overview

2.1 Label Locations

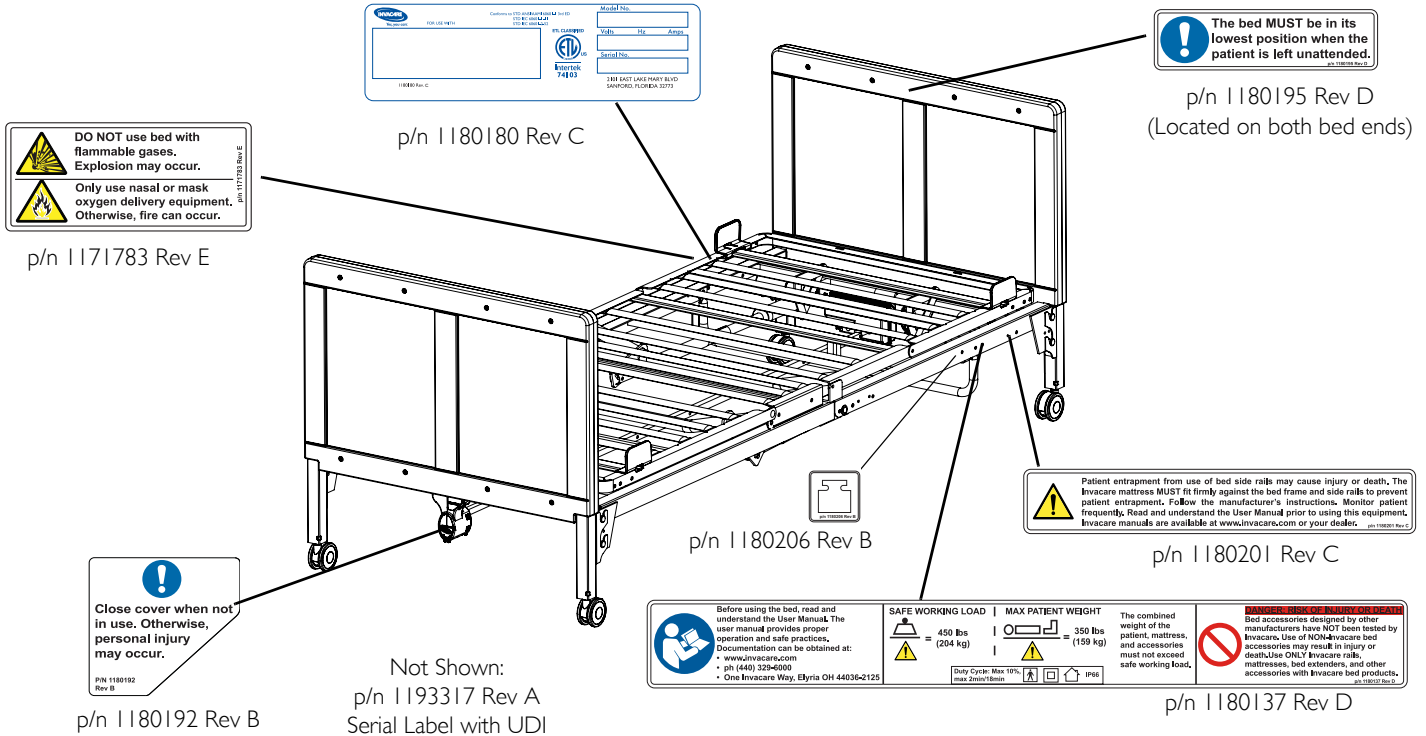

2 OVERVIEW

These labels are located on the pendant cord.

p/n 1171778 Rev B



* p/n 1180191 Rev C

* This label is also located on the emergency crank.

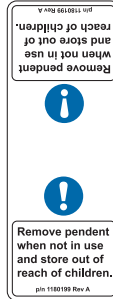
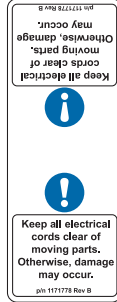

p/n 1180199 Rev A

These labels are located on the power supply.



p/n 1180193 Rev B

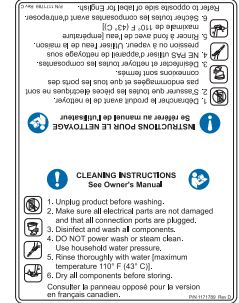

p/n 1171789 Rev D

*Labels shown for location and notice. Labels may change without notice. Contact your service provider or Invacare if label is missing or unreadable.

2.2 Specifications

Description	Full Electric Bed
Shipping Weight	183 lbs (83 kg)
Total Product Weight	158 lbs (71.6 kg)
Head Section Weight.....	47 lbs (21.3 kg)
Foot Section Weight.....	57 lbs (25.8 kg)
Bed End Weight	54 lbs (24.5 kg)
Safe Working Load	450 lbs (204 kg)
Maximum Patient Weight	350 lbs (159 kg)
Overall Length	88 in. (223.5 cm)
Overall Width	36 in. (91.4 cm)
Under bed clearance (at center of bed)	7.5 in. (19.0 cm)
Adjustment Range	
Deck*.....	15.25 to 32.25 in. \pm 2 in. (38.73 to 81.91 cm \pm 5 cm)
Bed End (G53).....	35.0 to 52.0 in. (88.9 to 132.1 cm)
Head Section (G50).....	43 in. (109.2 cm)
Foot Section (G54).....	45 in. (114.3 cm)

*The G-Series bed is capable of a height adjustment range of 15.25 \pm 2 to 32.25 \pm 2 inches. Under Normal Use, the bed should operate in a height range of 15.25 \pm 2 to 23.00 \pm 2 inches.

Electrical Requirements	120 VAC, 60 Hz
Rated Current Input	2.9 A max (full system)
Duty Cycle	10%, max 2 min/18 min
Electrical Components	Type BF Components IP66 min.
Results of Acoustic Testing	Under 75 db
Head Angle Range	0° to 70° (+0° to -10°)
Foot Angle Range	0° to 20° (+0° to -10°)
Recommended Storage and Shipping Temperature	
	-22°F to 158°F (-30°C to 70°C) (up to 93% relative humidity, non condensing)
Recommended Operating Temperature	
	41°F to 104°F (5°C to 40°C) (15% to 93% relative humidity, non condensing)
Recommended Atmospheric Pressure	
	700 hpa to 1060 hpa

2 OVERVIEW

Regulatory Listing: ANSI/AAMI 60601-1 3rd Edition, ANSI/AAMI 60601-1 I, IEC 60601-2-52

Application Environment 3-LTC - Long term care in a medical area where medical supervision is required and monitoring is provided, if necessary, and medical electrical equipment used in medical procedures may be provided to help maintain or improve the condition of the patient.

Application Environment 4-Domestic - Care provided in a domestic area where medical electrical equipment is used to alleviate or compensate for an injury, disability, or disease.

Product Description

The G5510 bed is a steel framed medical bed that allows for deck height adjustability and mattress deck articulation through the use of electronic actuators.

The G5510 bed is for assisting in diagnosis, monitoring, prevention, treatment, alleviation of disease, or compensation for an injury or disability in an indoor environment.

Interaction of Patient with Bed

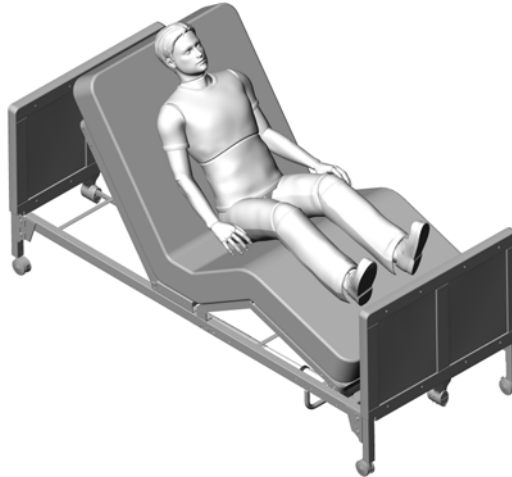

2.3 Accessories and Accessory Weight



DANGER!

Risk of Injury or Damage

Improper use of this product may cause injury or damage.

- If you are unable to understand the warnings, cautions or instructions, contact a healthcare professional, dealer or technical personnel before attempting to use this equipment.
- Do not use this product or any available optional equipment without first completely reading and understanding these instructions and any additional instructional material such as user manuals, service manuals or instruction sheets supplied with this product or optional equipment.

The accessories in this table have been tested with the bed to meet the international bed standard IEC 60601-2-52:	DESCRIPTION	MODEL NUMBER	WEIGHT
	BED RAIL, FULL LENGTH	G29	26 lbs (11.8 kg)
	BED RAIL, HALF LENGTH	G30	29 lbs (13.1 kg)
	BED RAIL ARTICULATING HEAD RAILS	G32	23 lbs (10.4 kg)
	MATTRESS	SPS1080 (80 in. Long x 36 in. Wide x 6 in. High)	21 lbs (9.5 kg)
		SPS1084 (84 in. Long x 36 in. Wide x 6 in. High)	24 lbs (10.9 kg)
TRAPEZE	G7740CS	25 lbs (11.3 kg)	



The G7740P trapeze is not approved for use with the G-series bed.

The 6628, 6628-TSS, G6629, 6629, G6630, 6630, and 6632 bed rails are not approved for use with the G-series bed.

The 5143IVC and 5143A bed extenders are not approved for use with the G-series bed.

2 OVERVIEW

The accessories in this table have not been tested to the international bed standard IEC 60601-2-52. They have been tested to comply with FDA Entrapment Guidelines when used with the G5510 bed and rails.

DESCRIPTION	MODEL NUMBER	WEIGHT
MATTRESS	5180	13.6 lbs (6.2 kg)
	5185	26.6 lbs (12.1 kg)
	SPS1080RSR	21.2 lbs (9.6 kg)
	SRS2080	26.0 lbs (11.8 kg)
	SRS2080RSR	27.0 lbs (12.2 kg)
	IXL1080	28.2 lbs (12.8 kg)
	IPM1080	28.0 lbs (12.7 kg)
	IXL1080VERUS	26.8 lbs (12.2 kg)
	IXL1080VITAS	27.2 lbs (12.3 kg)
	microAir Series*	17 - 56 lbs (7.7 - 25.4 kg) varies depending on model
STOR A BED	5142	8 lbs (3.6 kg)

*The microAir series of air mattresses are excluded from the FDA Entrapment Guidelines tests.

2.4 Optional Touch-up Paint

Sherwin-Williams®

5A-58147 00(A)

CODE 82X

WHITE BIRCH

2nd Dimension 5.0 Acrylic Enamel

This product can be purchased at Sherwin Williams Automotive paint branches only.

3 Safety

3.1 General Guidelines



The Invacare G5510 Bed has been engineered to provide reliable operation. The bed has been thoroughly tested and inspected prior to shipment.



DANGER!

Risk of Death, Injury or Death

Bed accessories designed by other manufacturers have **NOT** been tested by Invacare. Use of **NON-Invacare** bed accessories may result in injury or death.

- Use **ONLY Invacare** rails, mattresses, bed extenders and other accessories with Invacare bed products.

DANGER!

Risk of Death, Injury or Damage

Improper use of this product may cause injury or damage.

- If you are unable to understand the warnings, cautions or instructions, contact a healthcare professional, dealer or technical personnel before attempting to use this equipment.

- Do not use this product or any available optional equipment without first completely reading and understanding these instructions and any additional instructional material such as user manuals, service manuals or instruction sheets supplied with this product or optional equipment.

To avoid injury or product damage:

Set-up and Assembly instructions **MUST** be performed by a qualified technician only. “Qualified Technician Only” sections are marked accordingly.

3 SAFETY



DANGER!

Risk of Death, Injury or Damage

Continued use of the product with damaged parts could lead to the product malfunctioning, causing injury to the user and/or caregiver.

- Check ALL product components and carton for damage, and test components before use. DO NOT use product if components are damaged or if product is not working properly. Contact a qualified technician or Invacare for repair.

Conditions such as restlessness, mental deterioration and dementia or seizure disorders (uncontrolled body movement), sleeping problems, and incontinence can significantly impact a patient's risk of entrapment. Pediatric patients or patients with small body size may also have an increased risk of entrapment.

- Monitor patients with these conditions frequently.
- Place the mattress deck in the flat position when left unattended.



DANGER!

Risk of Death, Injury or Damage

Lighted cigarettes can cause a fire or other related hazards resulting in death, injury or damage.

- Do not smoke while using this product.
- Do not allow others to smoke near this product.



WARNING!

Risk of Injury or Damage

Use of the product beyond this time period may cause product damage and injury.

-This product has an expected lifetime of seven (7) years when used in accordance with safety instructions, maintenance intervals and correct use stated in this manual.

-Perform all maintenance according to the recommended schedule in this manual.



The effective bed lifetime can vary according to the frequency and intensity of use.



NOTICE

THE INFORMATION CONTAINED IN THIS DOCUMENT IS SUBJECT TO CHANGE WITHOUT NOTICE.



The slats may take a relaxed position over time. This is normal and there is no compromise to the bed's structure. This is not a warranty issue.

The slats are designed as part of an integral sleep surface. Be careful not to stand on individual slats or drop on rigid objects as localized bending may occur.

DO NOT use the slats as a hand hold to assemble/disassemble or move the bed, otherwise the slats may bend resulting in permanent damage.



Disposal of Equipment and Accessories

Follow local governing ordinances and recycling plans regarding disposal of the device or components normally used in operation. The device does not generate waste or residue in operation. Any accessories not part of the device **MUST** be handled in accordance with the individual product marking for disposal.

3 SAFETY

Electrical



DANGER!

Risk of Death, Injury or Damage

Shock hazards and risk of fire exist due to use of improper extension cord and use of three prong adapters.

- To avoid injury or product damage, when using an extension cord, use only an extension cord having at least 16 AWG (American Wire Gauge) wire and the same or higher electrical rating as the device being connected.

To reduce the risk of electric shock, this furnishing has a polarized plug (one blade is wider than the other). This plug will fit in a polarized outlet only one way.

- If the plug does not fit fully in the outlet, reverse the plug. If it still does not fit, contact a qualified electrician to install the proper outlet.
- DO NOT change the plug in any way.



NOTICE

Protection to the user against electrical shock hazard is provided by using double insulated construction. Servicing a double-insulated product requires extreme care and knowledge of the system, and is to be done only by qualified service personnel. Replacement parts for a double-insulated product must be identical to the parts they replace. A double-insulated product is marked with the words “DOUBLE INSULATION” or “DOUBLE INSULATED”. The symbol (□) is also able to be marked on the product.

Electrical

**DANGER!****Risk of Death, Injury or Damage**

To avoid serious injury or product damage due to tripping, strangulation, entanglement and/or pinched, or severed cords:

- Ensure that all cord(s) are routed and secured properly.
- Keep all moving parts, including the main frame, mattress deck, and all drive shafts, free of obstruction (i.e. blankets/sheets, tubing, wiring, cords, etc.) during operation of the product.
- Do not roll the product over the power or pendant cord.

**WARNING!****Risk of Product Damage**

To avoid product damage:

- DO NOT open assemblies such as the motors, pendant, junction boxes or gear boxes. No user serviceable parts are inside. Contact dealer or Invacare for repair/replacement.
- Ensure gear box cover and all other assemblies are closed.
- Unplug the power cord from its power source before performing any maintenance on the product. DO NOT unplug the power cord from the power supply. Damage to cord will result.

3 SAFETY



CAUTION!

Risk of Damage

To avoid damage to the power supply or the bed malfunctioning:

- To prevent overheating, the power supply **MUST** not be covered during bed operation (i.e. pillows, blankets, etc.).

Entrapment Warning



DANGER!

Risk of Death, Injury or Damage

To avoid injury or damage from misuse or entrapment:

-Proper patient assessment and monitoring, and proper maintenance and use of equipment is required to reduce the risk of entrapment. Variations in bed rail dimensions, and mattress thickness, size or density could increase the risk of entrapment.

- Visit the FDA website at <http://www.fda.gov> to learn about the risks of entrapment. Review “A Guide to Bed Safety”, published by the Hospital Bed Safety Workgroup. Use the link located under each bed rail product entry to access this bed’s safety guide.

Operating Information



DANGER!

Risk of Death, Injury, or Damage

To avoid electrical damage, product damage, shock and/or personal injury:

- Keep all product components and accessories a minimum of 12 inches away from hot or heated surfaces.

Operating Information



WARNING!

Risk of Injury or Damage

Continued use of the product with damaged parts could lead to the product malfunctioning, causing injury to the user and/or caregiver.

- Check ALL product components and carton for damage, and test components before use. DO NOT use product if components are damaged or if product is not working properly. Contact a qualified technician or Invacare for repair.
- Before operating the bed, detach the power supply from the slat located under the bed. Keeping the power supply attached to the slat may cause overheating resulting in the bed malfunctioning.



DANGER!

Risk of Death, Injury or Damage

To avoid pinching, crush and collapse hazards from bed deck contact with objects under the bed:

- DO NOT place any objects or let any individual underneath the bed or in between the raised bed frame components at any time.

To avoid risk of death or injury from choking or ingestion of small parts or materials:

- Closely supervise children, pets, or individuals with physical/mental disabilities.

3 SAFETY

Operating Information



DANGER!

Risk of Death, Injury or Damage

To reduce the risk of shock:

- When the bed is not to be used for an extended period, unplug the bed from the wall outlet.
- If liquid is spilled in or around the product, unplug before cleaning. Clean up the spill and allow the product or the area around the product to dry thoroughly before using the controls again.
- If the product is not working properly, contact a qualified technician or Invacare for repair.



DANGER!

Risk of Death, Injury or Damage

To avoid injury or damage when operating product:

- The product is not designed to be used as a patient transport. When transporting a patient, use an approved patient transport. Otherwise, injury or damage may result.

Operating Information



DANGER!

Risk of Death, Injury or Damage

To avoid injury or damage when operating/moving bed:

- Bed is only meant to be moved about patient room for cleaning or access purposes.
- Only use bed indoors.
- DO NOT use near explosive gases.
- ALWAYS ensure that the individual utilizing the bed is positioned properly within the confines of the bed. DO NOT let any extremities protrude over the side or between the bed rails when performing these functions.
- Make sure head and foot sections are connected securely to the bed ends before use.
- The bed is equipped with locking casters. Before using the bed, test the wheel locks to ensure casters lock correctly. When transferring into or out of the bed, ALWAYS lock the casters. Even with casters properly locked, some flooring surfaces (such as tile or wood) will allow the bed to move under some conditions. Using the bed on these types of surfaces MUST be evaluated by the care provider. DO NOT transfer occupant if bed is not stable. Otherwise, injury and/or damage may occur.
- DO NOT move product with locking casters in LOCKED position.

The emergency crank will turn when motor is on and could cause personal injury or damage to the bed.

- ALWAYS remove emergency crank(s) before performing electronic functions.



DANGER!

Risk of Death, Injury or Damage

To avoid bed collapse and resulting injury or damage:

- NEVER permit more than one individual on the bed at any time.
- Body weight should be evenly distributed over the surface of the bed. **DO NOT** lay, sit or lean in such a way that your entire body weight is placed only on raised head or foot sections of the bed. This includes when repositioning or transferring in or out of bed.
- **DO NOT** push on raised head or foot sections of the bed.
- After the product has been assembled and before use, always test to make sure that all sections of the bed are properly and securely in place. If any problems arise during the test, recheck all electrical connections and mechanical hook ups and then retest. If the product is not working properly, contact a qualified technician or Invacare for repair.

Pendant Operation



WARNING!

Risk of Injury or Damage

A safety feature of this product includes protection against overheating caused by excessive or extended periods of operation. Depending on the duration, this includes multiple or repeated adjustments or the use of multiple functions at one time.

- To assure trouble free operation, ALWAYS allow a slight pause between multiple adjustments and avoid pressing more than one function button at a time.
- If thermal protection activation should occur, the bed will not respond to pendant commands. Given this situation, release the pendant button and allow the bed to sit for several minutes. This will allow the protection function time to reset and restore bed function. Depending on the severity of the initial overheating, this could take up to 30 minutes.



Pendant is constructed of latex-free materials.

3 SAFETY

Repair or Service Information



WARNING!

Risk of Injury or Damage

To avoid injury or damage:

- DO NOT open assemblies such as the motors, pendant, power supply or gear boxes. No user serviceable parts are inside. Contact dealer or Invacare for repair/replacement.
- To avoid product damage, all electric cable connections MUST be aligned properly. Align locking levers with locking tabs for proper connection.
- DO NOT force the connectors together.
- After any adjustments, repair or service and before use, make sure all attaching hardware is tightened securely.

Replacement Parts/Accessories



DANGER!

Risk of Death, Injury, or Damage

To avoid fire hazards and tubing entanglement:

- Use masked or nasal type oxygen administering equipment only in conjunction with the bed. The use of any other type of oxygen administering equipment can result in a fire hazard.
- When using nasal or masked type oxygen administering equipment, the oxygen or air tubing MUST be routed and secured properly to ensure that the tubing does not become entangled and/or severed during normal operation of the bed.
- DO NOT use product with flammable gases. Explosion may occur.



DANGER!

Risk of Death, Injury or Damage

To avoid injury or damage from fall or entrapment:

- Invacare recommends the use of mattress keepers.



DANGER!

Risk of Death, Injury or Damage

To avoid entrapment, product damage, and/or personal injury:

-Invacare recommends that the mattress be centered on the bed frame. Otherwise, individuals may become trapped between the bed rail and the bed frame.

-ALWAYS test to make sure that the side rails are properly and securely in place before using the bed. Otherwise, injury or damage may occur.

3 SAFETY



DANGER!

Risk of Death, Injury or Damage

To avoid entrapment, product damage and/or personal injury:

- When used with an Invacare bed, the bed rails **DO NOT** fall under any weight limitations. Bed rails can be deformed or broken if excessive side pressure is exerted on the bed rails. These bed rails are used for the purpose of preventing an individual from inadvertently rolling out of bed. The bed rails are not intended nor may be used for restraint purposes. If an individual is capable of injuring himself/herself, a physician or a healthcare professional should be consulted for alternative means of safe restraint.
- After raising/lowering the head/foot end of the bed, check the distance between the bottom of the bed rail and the mattress. If there is excessive distance between the bottom of the bed rail and the mattress in which individuals may become entangled, adjust the height of the bed rail (if applicable), or provide alternative means of patient protection.
- **DO NOT** use the side rails as push handles for moving the electric bed.
- Replacement mattresses and bed side rails with dimensions different from the original equipment supplied by or specified by the bed frame manufacturer are not interchangeable. Variations in bed side rail design, width and thickness or firmness of the mattress could cause/contribute to entrapment.
- The trapeze is to be used only in assisting the patient in repositioning or transferring into or out of the bed.
- **NEVER** allow patients to use trapeze or traction units as a total individual weight support.



Trapeze units **MUST** be positioned on a bed end as near as possible to the center point of the bed end.

Weight Limitations**DANGER!****Risk of Death, Injury or Damage**

To avoid bed collapse and resulting injury or damage:

- The weight limit of the occupant of the bed **CANNOT** exceed 350 lbs (159 kg). The **TOTAL** weight limit of the bed (including accessories, mattress, occupant and any other objects positioned on the bed) cannot exceed 450 lbs (204 kg.) (Safe Working Load).
- **NEVER** permit more than one individual on the bed at any time.
- Body weight should be evenly distributed over the surface of the bed. **DO NOT** lay, sit or lean in such a way that your entire body weight is placed only on raised head or foot sections of the bed. This includes when repositioning or transferring in or out of bed.

3 SAFETY

Using Lifts with the G5510 Bed



WARNING!

Risk of Injury or Damage

To avoid injury or damage from crush hazard:

- Caregivers **MUST** be aware of the bed-floor clearance when using lifts or any other device that assists the bed user that enters between the lowest component of the bed and the floor.

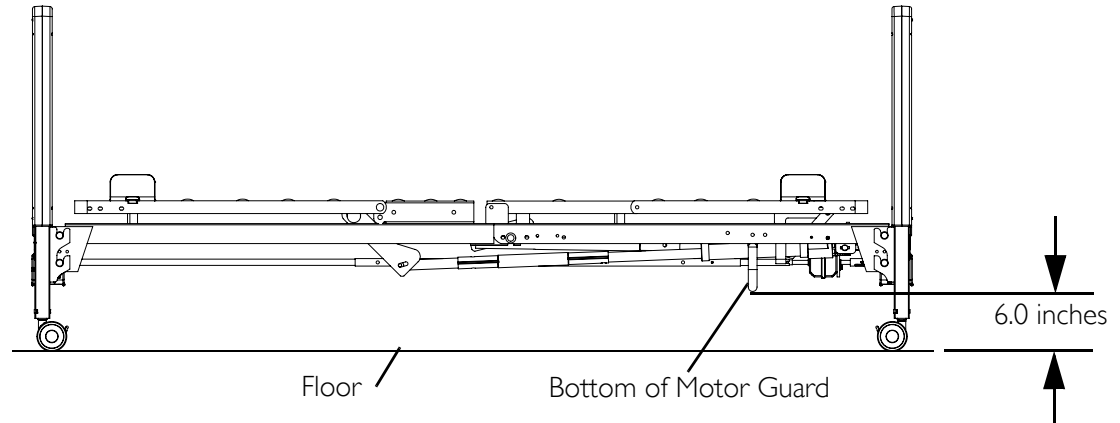

4 EMC Information

4.1 Electromagnetic Compatibility (EMC) Information



Medical Electrical Equipment needs special precautions regarding EMC and needs to be installed and put into service according to the EMC information provided in this manual.

Radio Frequency Interference



WARNING!

Risk of Injury or Damage

Electronic equipment may be influenced by Radio Frequency Interference (RFI).

- Caution should be exercised with regard to the use of portable communications equipment in the area around such equipment.
- If RFI causes erratic behavior, unplug the electric bed IMMEDIATELY. Leave unplugged while transmission is in progress.



WARNING!

Risk of Injury or Damage

The use of accessories, transducers, cords and cables other than those specified by the manufacturer, may result in increased emissions or decreased immunity of this bed.

- This bed should not be used adjacent to or stacked with other equipment. If adjacent or stacked use with other equipment is necessary, this bed should be observed to verify normal operation in the configuration in which it will be used.

4 EMC INFORMATION

Recommended separation distances between portable and mobile RF communications equipment and the G 5510 Bed

The G 5510 Bed is intended for use in an electromagnetic environment in which radiated RF disturbances are controlled. The customer or the user of the G 5510 Bed can help prevent electromagnetic interference by maintaining a minimum distance between portable and mobile RF communications equipment (transmitters) and the G 5510 Bed as recommended below, according to the maximum output power of the communications equipment.

Rated maximum output power of transmitter W	Separation distance according to frequency of transmitter m		
	150 kHz to 80 MHz $d=1.2 \sqrt{P}$	80 MHz to 800 MHz $d=1.2 \sqrt{P}$	800 MHz to 2,5 GHz $d=2.3 \sqrt{P}$
0.01	.12	.12	.23
0.1	.38	.38	.73
1	1.2	1.2	2.3
10	3.8	3.8	7.3
100	12	12	23

For transmitters rated at a maximum output power not listed above, the recommended separation distance d in metres (m) can be estimated using the equation applicable to the frequency of the transmitter, where P is the maximum output power rating of the transmitter in watts (W) according to the transmitter manufacturer.

NOTE 1: At 80 MHz and 800 MHz, the separation distance for the higher frequency range applies.

NOTE 2: These guidelines may not apply in all situations. Electromagnetic propagation is affected by absorption and reflection from structures, objects and people.

5 Operation

Bed Operation and Component Overview

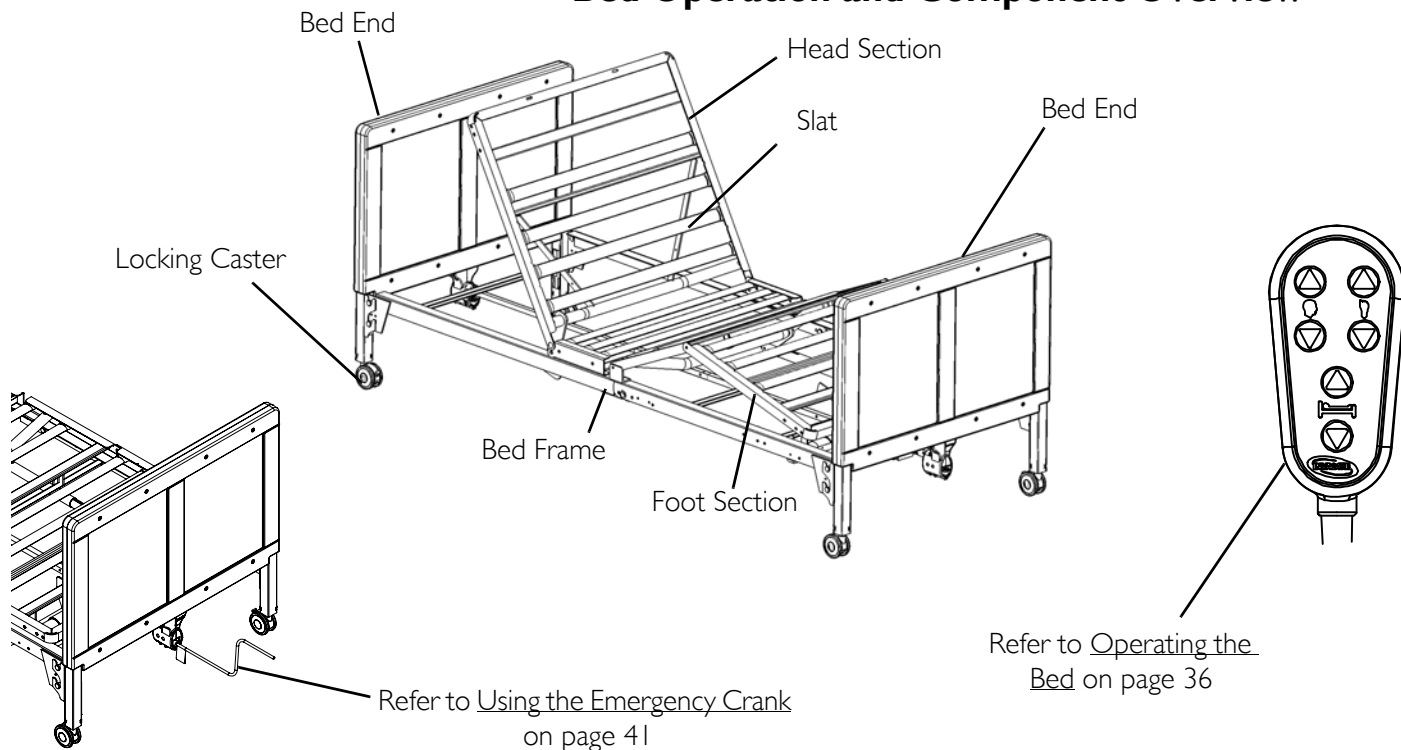

5 OPERATION



WARNING!

Risk of Injury or Damage

To avoid unintentionally pressing the pendant buttons and causing injury or damage:

- DO NOT place pendant under or between objects.



DANGER!

Risk of Death, Injury or Damage

To avoid serious injury or product damage due to tripping, strangulation, entanglement and/or pinched, or severed cords:

- Ensure that all cords are routed and secured properly.



DANGER!

Risk of Death, Injury or Damage

To avoid pinching, crush and collapse hazards from bed deck contact with objects under the bed:

- DO NOT place any objects or let any individual underneath the bed or in between the raised bed frame components at anytime.



CAUTION!

Risk of Damage

To avoid damage from misuse:

- Bed operation is intended for a duty cycle not to exceed max 10%, max 2 min./18 min. This includes multiple or repeated adjustments or the use of multiple functions at one time.
- ALWAYS allow a slight pause between multiple adjustments and avoid pressing more than one function button at a time.
- If a button on the pendant does not release or sticks, the bed section will not stop moving. If this occurs or any other malfunction, unplug the bed from the electrical wall outlet.

5.1 Operation Verification



Before placing any bed into use, test it by operating it through all phases of its operation.

If any problems arise during the test, recheck all electrical connections and mechanical hook ups.

This bed uses a six function pendant for all bed operations.

This bed is equipped with an emergency crank to allow operation in the event of a power outage.

Keep power supply as close to the electrical outlet as possible.

5 OPERATION

5.2 Operating the Bed



For this procedure, refer to FIGURE 1 on page 37.

To disable operation of the electric bed, lift connector cap and unplug the pendant cable from the bus cable port.

To cut power to the bed, remove the power cord plug from the electrical outlet.

Raising and Lowering the Entire Bed

- To raise the entire bed, press the "Bed Up" button.
- To lower the entire bed, press the "Bed Down" button.



The G-Series bed is capable of a height adjustment range of 15.25 ± 2 to 32.25 ± 2 inches. Under Normal Use, the bed should operate in a height range of 15.25 ± 2 to 23.00 ± 2 inches.

Raising and Lowering the Head and Foot Sections

- To raise the head of the bed, press the "Head Up" button; To lower the head of the bed, press the "Head Down" button.
- To raise the foot of the bed, press the "Foot Up" button; To lower the foot of the bed, press the "Foot Down" button.

5 OPERATION

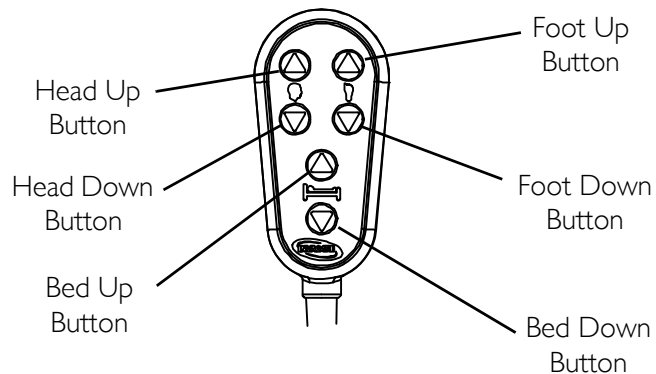
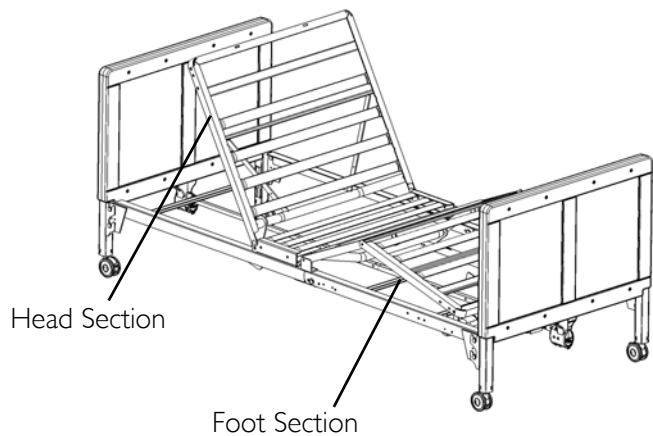

FIGURE I Operating the Bed

5 OPERATION

5.3 Operating the Locking Function on the Locking Caster



Locking the casters may not prevent the bed from moving on slick or slippery surfaces.

- LOCK - Push down on the lever.
- UNLOCK - Pull up on the lever.

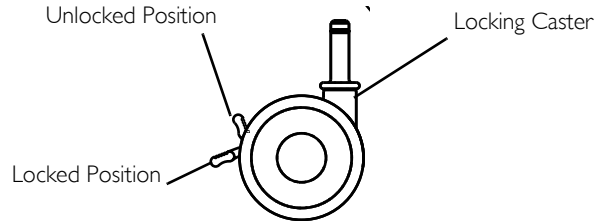

FIGURE 2 Operating the Locking Function on the Locking Caster

5.4 Electrical Connections



When installing/removing pendant cable, port cover, or power supply to bus cable, ensure that flat edge of each connector is aligned with the flat edge of the corresponding connector.

Pendant Connector

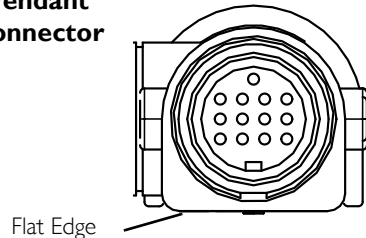

Pendant/Port Cover Connection

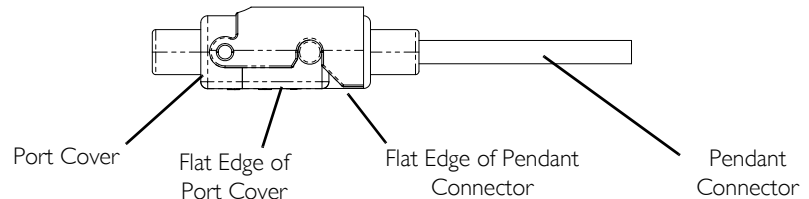

FIGURE 3 Electrical Connections

5.5 Installing/Removing Pendant and/or Port Cover



For this procedure, refer to FIGURE 4 on page 40.

Installing Pendant

1. Plug pendant cable into bus cable port located on either right or left side (Detail “A”).



Ensure connection between pendant cable and bus cable port is tight, otherwise, connector cap will not lock in place (Detail “B”).

2. Lower connector cap to lock the connection in place (Detail “C”).

Removing Pendant



To disable the operation of electric beds, these models have pendants that can be removed and stored in a secure place.

1. To disable operation of the electric bed, lift the connector cap (Detail “B”).
2. Unplug the pendant cable from the bus cable port (Detail “A”).

Installing Port Cover

There is a port on each side of the bed for the pendant to be plugged in to that allows the pendant to be located on either side of the bed. The port that is not being used **MUST** be covered using the provided port cover.

1. In the unused port of the bus cable, install port cover (Detail “D”).



Ensure connection between the bus cable and port cover is tight, otherwise, connector cap will not lock in place (Detail “E”).

2. Lower connector cap to lock the connection in place (Detail “F”).

Removing Port Cover

1. To remove the port cover, lift the port cover cap (Detail “E”) and remove the port cover from the bus cable port.

5 OPERATION

Pendant Cable
and Bus Cable
Port

PENDANT

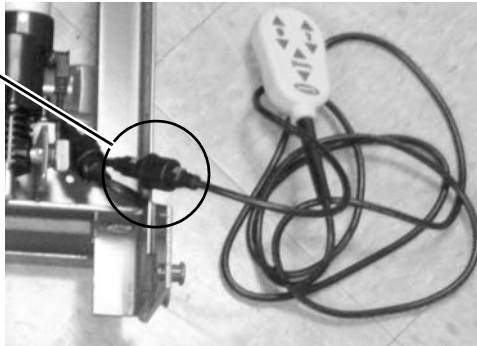

PORT COVER

Unused Port



Bus Cable

Connector Cap

Detail "A"

Bus Cable Port

Pendant Cable



Unused Port

Detail "D"

Connector Cap

Port Cover



Detail "B"

Connector Cap



Connection **MUST** be
tight

Detail "C"

Pendant Cable Cap



Pendant Cable

Bus Cable Port

Detail "E"

Connector Cap



Connection **MUST** be
tight

Detail "F"

Connector Cap

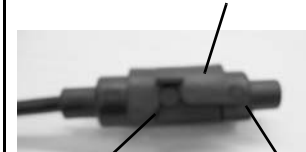

Bus Cable Port

Port Cover

FIGURE 4 Installing/Removing Pendant and/or Port Cover

5.6 Using the Emergency Crank



If the bed needs to be adjusted manually due to a power outage or an electronic malfunction, use the emergency crank to make the adjustments. You should find the emergency crank attached to the slats. If you do not find the crank, contact your dealer.

1. Disconnect the pendant from the bus cable.
2. Remove the emergency crank.
3. Locate the exposed shaft end according to the function you want to perform. Refer to FIGURE 5.
4. Attach the emergency crank to one of the following:
 - Shaft of head actuator to raise/lower head section.
 - Shaft of Gearbox to raise/lower the entire bed.
 - Shaft of foot actuator to raise/lower foot section.
5. Push in the emergency crank while turning it the desired direction. Turn clockwise to raise. Turn counterclockwise to lower.

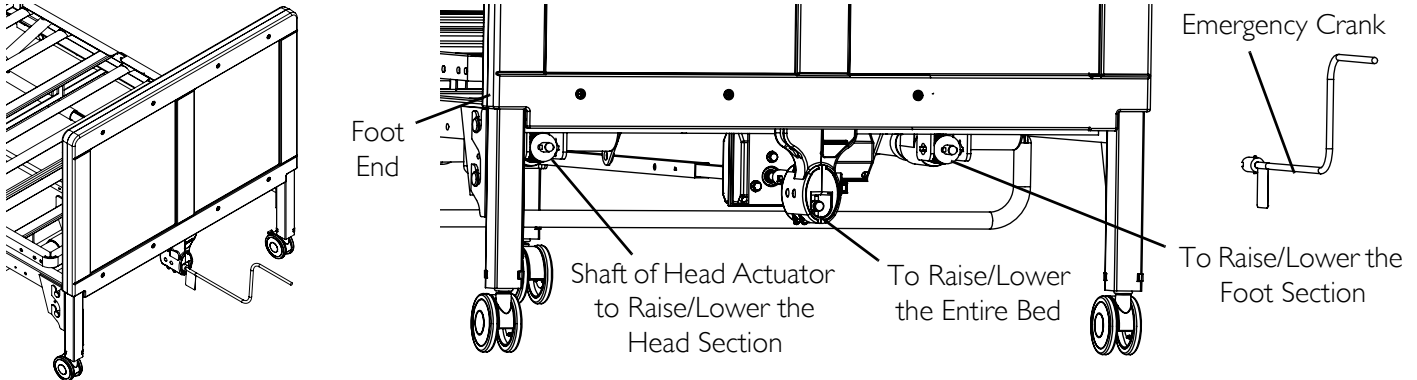

FIGURE 5 Using the Emergency Crank

5 OPERATION

5.7 Optional Bed Rails



DANGER!

Risk of Death, Injury, or Damage

Proper patient assessment and monitoring, and proper maintenance and use of equipment is required to reduce the risk of entrapment. Variations in bed rail dimensions, and mattress thickness, size or density could increase the risk of entrapment.

- Visit the FDA website at <http://www.fda.gov> to learn about the risks of entrapment. Review “A Guide to Bed Safety”, published by the Hospital Bed Safety Workgroup. Use the link located under each bed rail product entry to access this bed’s safety guide.

6 Dealer Section - Packaging, Handling, and Set-Up



WARNING!

Risk of Injury or Damage

The procedures in this section **MUST** be performed by a qualified technician.
Any modifications to the G5510 bed are strictly prohibited.

6.1 Unpacking and Handling



DANGER!

Risk of Death, Injury or Damage

To avoid injury or damage from electrical shock or misuse:

- DO NOT plug the power cord into a power source until assembly is complete. To do so could result in damage or personal injury.
- DO NOT attempt to operate bed controls prior to completion of assembly, otherwise damage to bed components may occur.

Unpacking the Bed Ends

1. Remove any loose packing from the carton.
2. Bed End carton includes:
 - Two Bed Ends - Any surface of the bed ends may be gripped for handling except the gear box.

- Four Locking Casters.
- One Drive Shaft Assembly in two pieces.

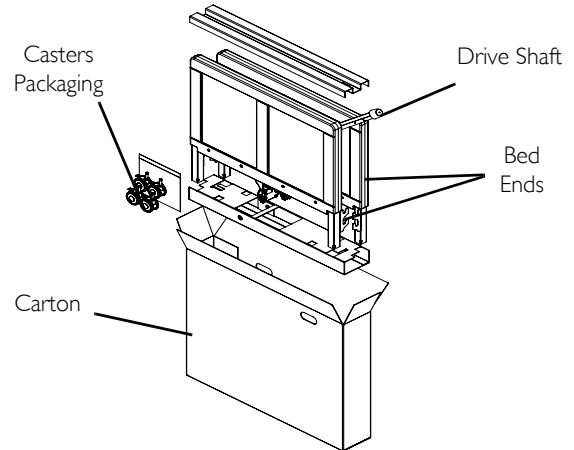

FIGURE I Unpacking the Bed Ends

6 DEALER SECTION - PACKAGING, HANDLING, AND SET-UP

Unpacking Foot and Head Sections

1. Remove any loose packing from the carton.
2. Foot Section carton includes: One Foot End Section (electric beds include pendant, power supply with power cord, and head, foot and hi/lo motors with cables), and one emergency crank handle. Only frame members should be gripped on the foot section for handling.
3. Head Section carton includes: One Head End Section. Any part of the head section may be gripped for handling.

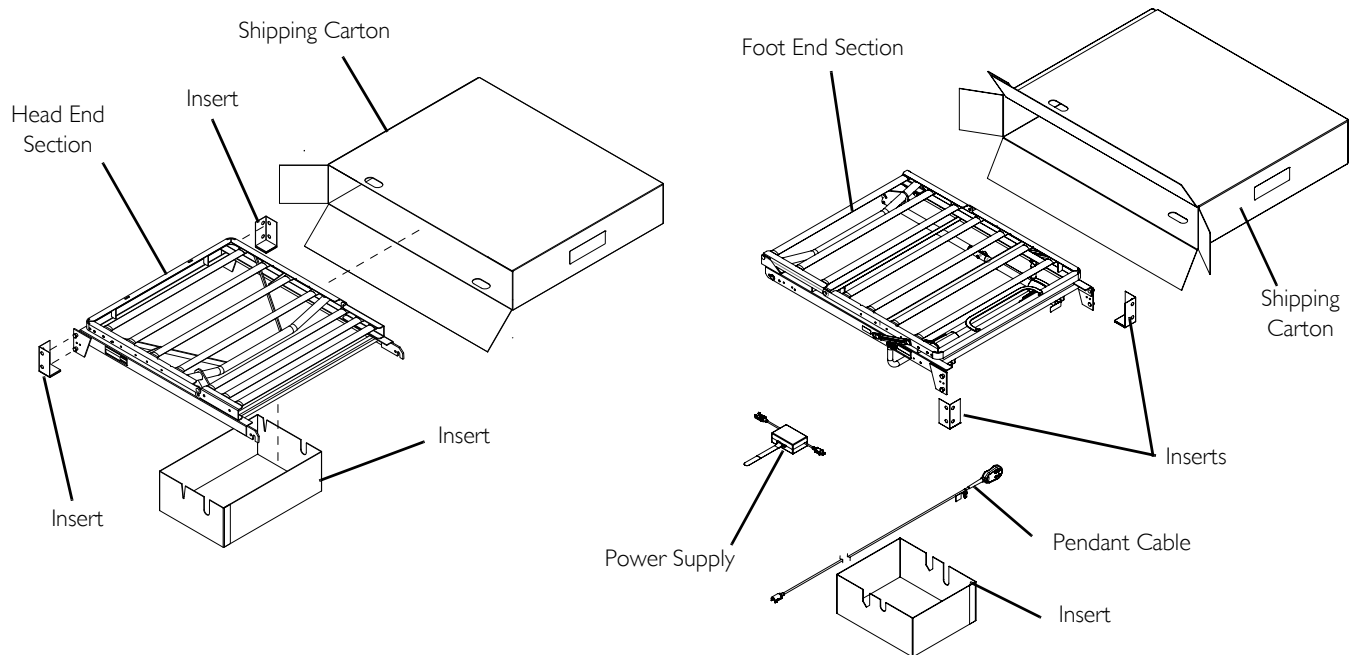

FIGURE 2 Unpacking Foot and Head Sections

6.2 Inspecting



DANGER!

Risk of Injury or Damage

To avoid injury or damage, inspect the following and contact a qualified technician or Invacare if any of the following issues are present:

- Pendant covering is cracked or damaged.
- Power cord or plug have cuts or damage.
- Motor cables have cuts or damage.
- Power supply or connectors are damaged.
- Emergency crank is missing or damaged.

6.3 Set-Up

Assembling the Head and Foot Sections



For this procedure, refer to [Assembling the Head and Foot Sections](#) on page 46.



WARNING!

Risk of Injury or Damage

To avoid injury or damage:

- DO NOT attempt to operate bed controls prior to completion of assembly.

CAUTION!

DO NOT use the slats as a hand hold to assemble/disassemble or move the bed, otherwise the slats may bend resulting in permanent damage.

6 DEALER SECTION - PACKAGING, HANDLING, AND SET-UP

1. Remove the head section (G50) and foot section (G54) of the bed from their packing cartons.
2. Place the head section on its side to your left so the center mounting latches are on the right.
3. Open the head section to a 45° to 90° angle for support.
4. Place foot section on its side to your right with the head section pull tube at the top of the assembly. The center mounting rivets should be on the left.

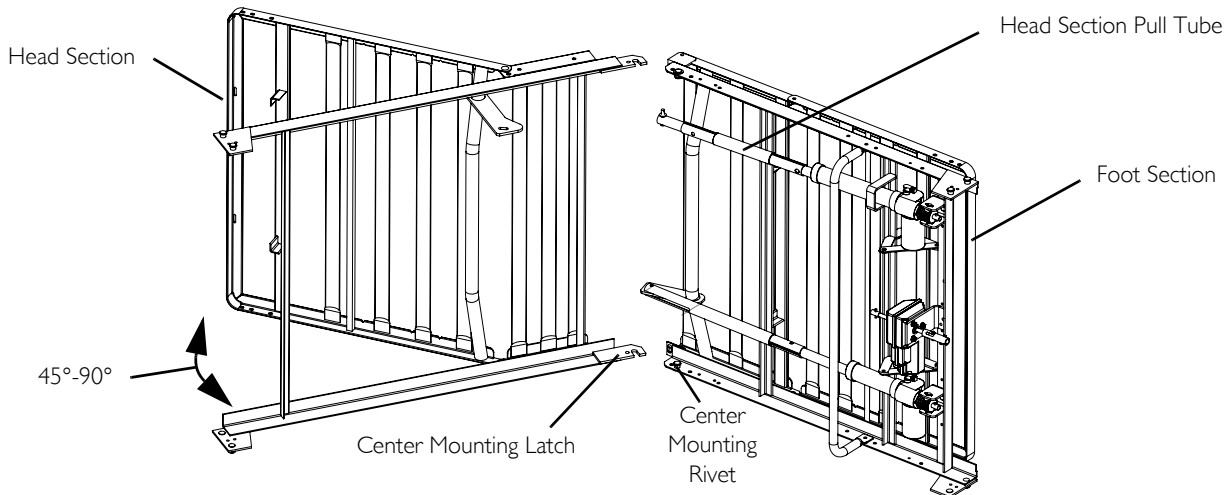

FIGURE 3 Assembling the Head and Foot Sections



For set-up purposes, the motors on the foot section as well as the crank handles should be on your right.

5. Place the head and foot sections approximately 90° from each other.
6. Hook the bottom head section center mounting latch to the bottom foot section center mounting rivet (FIGURE 4).
7. Hook the top head section center mounting latch to the top foot section center mounting rivet (FIGURE 4).

6 DEALER SECTION - PACKAGING, HANDLING, AND SET-UP



It may be necessary to lift the head section or foot section slightly to secure the mounting latches and rivets.

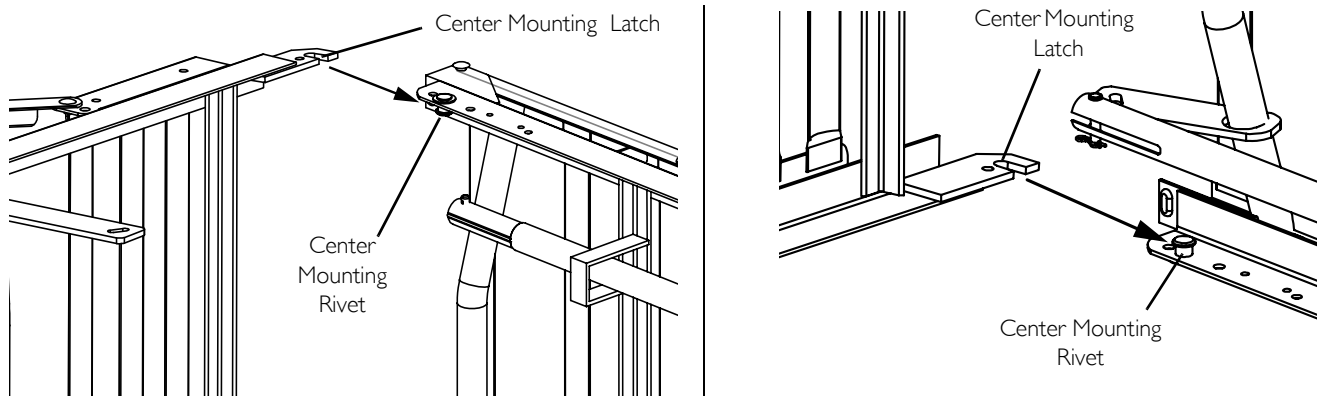

FIGURE 4 Inspecting - Assembling the Head and Foot Sections

8. After head and foot sections are connected, push the sections into a horizontal (straight) position while keeping the sections on their sides.

Adjusting and Reconnecting the Head Section Pull Tube



For this procedure, refer to FIGURE 5 on page 48.

1. To disconnect the head pull tube assembly from the side frame of the foot sections, remove the hitch pin, grommet/washer from the clevis pin (Detail "A").
2. Extend the inner pull tube shaft manually until the sections button "clicks" into the adjustment hole of the outer pull tube.
3. Connect the pull tube end assembly to the lift arm of the head section as follows (Detail "B"):
 - A. Insert the clevis pin into the lift arm slot.
 - B. Replace the grommet/washer.
 - C. Secure with hitch pin.

6 DEALER SECTION - PACKAGING, HANDLING, AND SET-UP

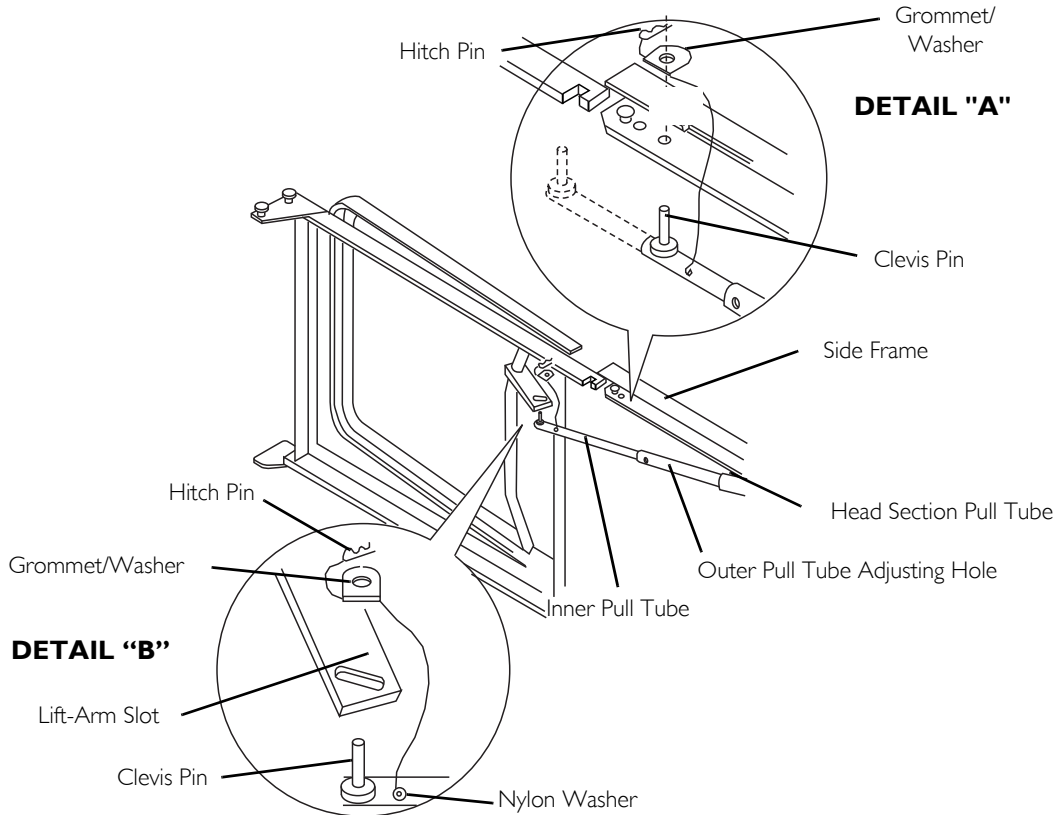

FIGURE 5 Adjusting and Reconnecting the Head Section Pull Tube

6 DEALER SECTION - PACKAGING, HANDLING, AND SET-UP

6.4 Assembling the Bed Ends

Installing the Casters



WARNING!

Risk of Injury or Damage

Ensure that all four casters are locked and that the bed does not move before transferring.

- DO NOT transfer occupant to the bed if bed is not stable.



For this procedure, refer to FIGURE 6 on page 49.

1. Lay the bed end flat on the floor.

2. Insert the shaft of a locking caster assembly into the caster socket in the leg of one of the bed ends.
3. To prevent excess movement of the bed during assembly, lock the caster. Refer to Operating the Locking Function on the Locking Caster on page 38.
4. Repeat STEPS 1-3 for the remaining casters.

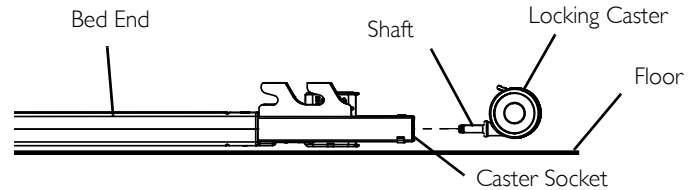

FIGURE 6 Assembling the Bed Ends

Installing/Removing the Bed Ends

Installing



For this procedure, refer to FIGURE 7 on page 50.

1. Stand one bed end as close to the head section as possible (Detail “A”).
2. Grasp the head section, by the side, and raise it until the rivets on the corner plates of the section are high enough to place into the corner locks on the bed end (Detail “A”).

6 DEALER SECTION - PACKAGING, HANDLING, AND SET-UP



WARNING!

Risk of Injury or Damage

To avoid injury or damage while assembling:

DO NOT place your hand between the section and the bed end.

3. Tilt the bed end toward the head section and place the rivets into the corner locks (Detail “A”).
4. Return the bed end to its full upright position. The head section rivets will lock into place (Detail “A”).
5. Repeat the same procedure for other bed end (Detail “B”).

Removing

1. While holding the bed end at the foot of the bed, lift up on the foot section and disengage the rivets out of the corner locks (Detail “B”).
2. Place the bed end and foot section on the ground.
3. While holding the bed end at the head of the bed, lift up on the head section and disengage the rivets out of the corner locks (Detail “A”).

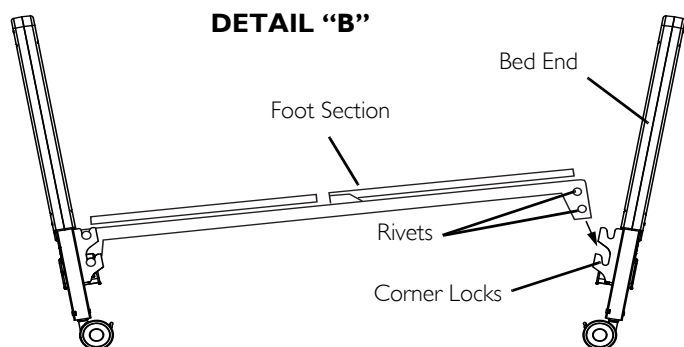
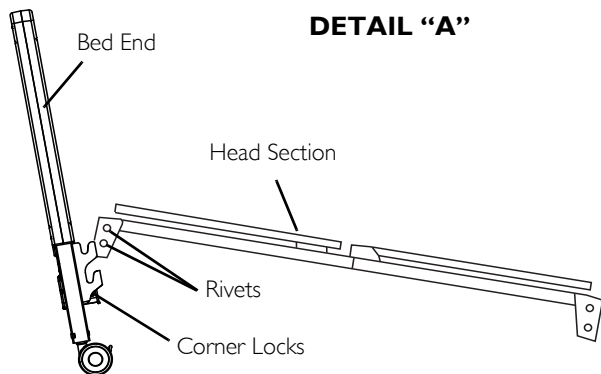

FIGURE 7 Installing/Removing the Bed Ends

Assembling the Drive Shaft



WARNING!

Risk of Injury or Damage

DO NOT attempt to operate bed controls prior to completion of assembly.

- Ensure gear box cover and all other assemblies are closed.



For this procedure, refer to FIGURE 8 on page 52 and FIGURE 9 on page 53.

The drive shaft for the Hi/Lo function consists of two sections that are shipped unassembled. The inner shaft has a positioning spring button, and the outer shaft has three positioning holes, one storage position hole and a telescoping end.

1. Remove the plastic caps from each end of the drive shaft.
 2. Press spring button on the inner shaft and insert the inner shaft into the outer shaft.
 3. Engage the spring button into the positioning hole.
-  A common gear box is used on both bed ends. The bottom output shaft is used at the head end and the top output shaft is used at the foot end of the bed.
4. Attach the inner shaft to the bottom gear box output shaft on the head end of the bed.
 5. Push in on the spring loaded end of the drive shaft and attach to the foot end of the bed as follows:
 - Attach drive shaft to the Hi/Lo motor output shaft facing head end of bed.

6 DEALER SECTION - PACKAGING, HANDLING, AND SET-UP

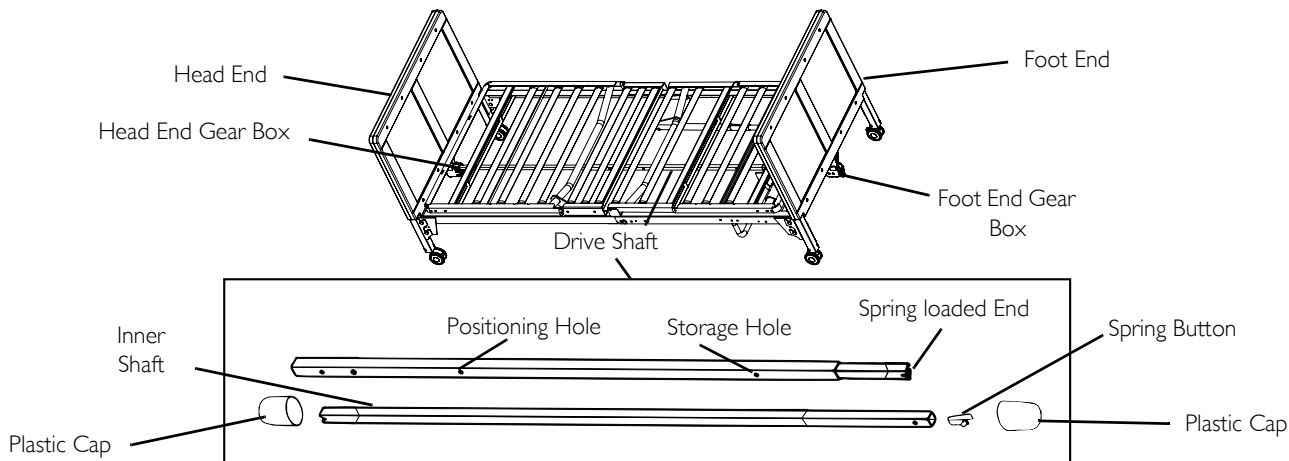
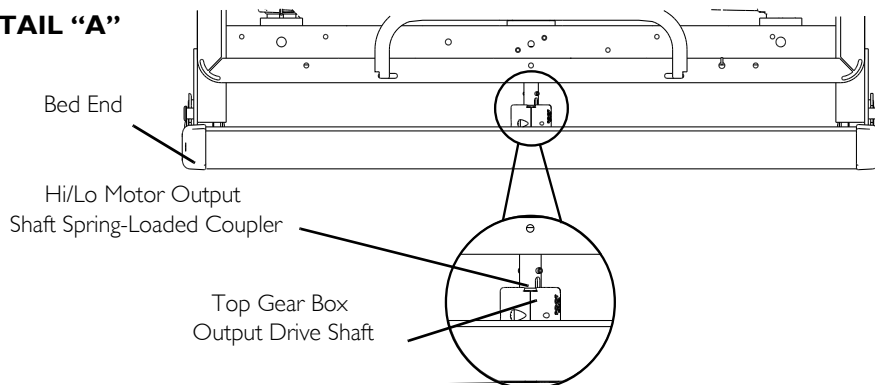

FIGURE 8 Assembling the Drive Shaft

- Attach the Hi/Lo Motor to the foot end gear box as follows:
 - i. Locate the Hi/Lo motor output shaft spring-loaded coupler.
- ① If necessary, shift bed end to right or left to align the Hi/Lo motor output shaft spring-loaded coupler with the foot end gear box.
- ii. Ensure the Hi/Lo motor output shaft spring-loaded coupler is properly aligned with the foot end gear box as shown in Detail “A” of FIGURE 9 on page 53.
- iii. Release the Hi/Lo motor output shaft spring-loaded coupler by pushing in against the Hi/Lo motor output shaft spring-loaded coupler and turning clockwise.
- iv. The coupling will release and engage the foot end top gear box output shaft cross pins.
- v. Ensure that all components are securely installed.

6 DEALER SECTION - PACKAGING, HANDLING, AND SET-UP

DETAIL "A"



LOCKED POSITION



UNLOCKED POSITION

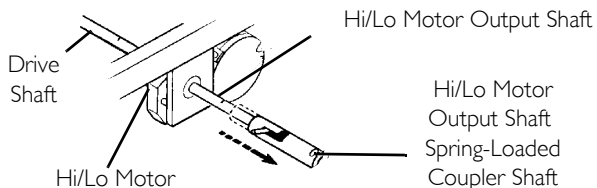

OUTPUT SIDE

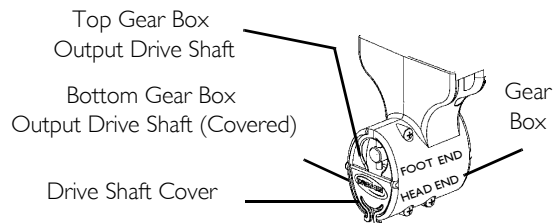

INPUT SIDE

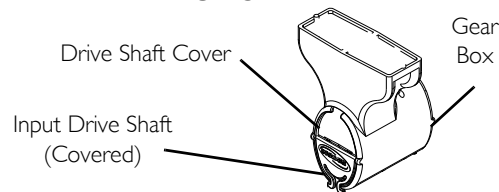

FIGURE 9 Assembling the Drive Shaft

6 DEALER SECTION - PACKAGING, HANDLING, AND SET-UP

Inspecting the Bed



WARNING!

Risk of Injury or Damage

To avoid product damage, all electric cable connections **MUST** be aligned properly. Align locking levers with locking tabs for proper connection.



All motors, power supply, connectors and wiring are located on the foot section.

Connect power supply and pendant. Each connector is labeled with its specific function.

1. Inspect the power supply cord and motor cables for cuts or damage to the cord and/or plug.
2. Inspect the power supply for any damage to the connectors.
3. Ensure that all cable plugs are connected securely.
4. Make sure all cables are routed properly.
5. If damage is found, contact an Invacare Customer Service Representative to report the damaged items and request appropriate replacement parts or products.
6. Make all the electrical connections. Refer to [Electrical Connections](#) on page 54.

6.5 Electrical Connections



When installing/removing pendant cable, port cover, or power supply to bus cable, ensure that flat edge of each connector is aligned with the flat edge of the corresponding connector.

6 DEALER SECTION - PACKAGING, HANDLING, AND SET-UP

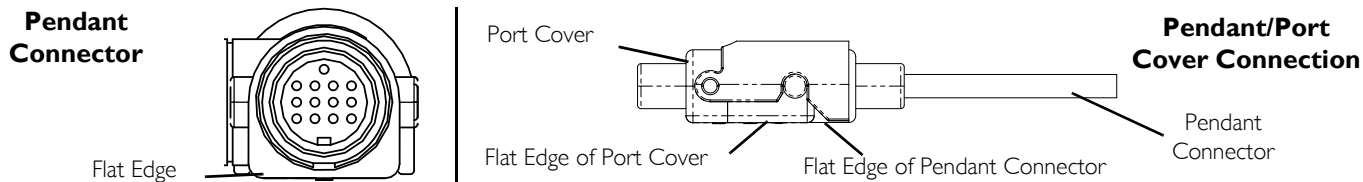

FIGURE 10 Electrical Connections

6.6 Installing/Removing Mattress Keepers



Recommended location for mattress keepers is on the end slat on either side of the bed.

Installing

1. Position mattress keeper over end slat as shown in Detail “B”.
2. Slide mattress keeper back until tab locks onto side rail as shown in Detail “C”.

Removing

1. Grasp mattress keeper and lift tab up to release from side rail (Detail “B”).
2. Slide mattress keeper off of end slat (Detail “B”).

6 DEALER SECTION - PACKAGING, HANDLING, AND SET-UP

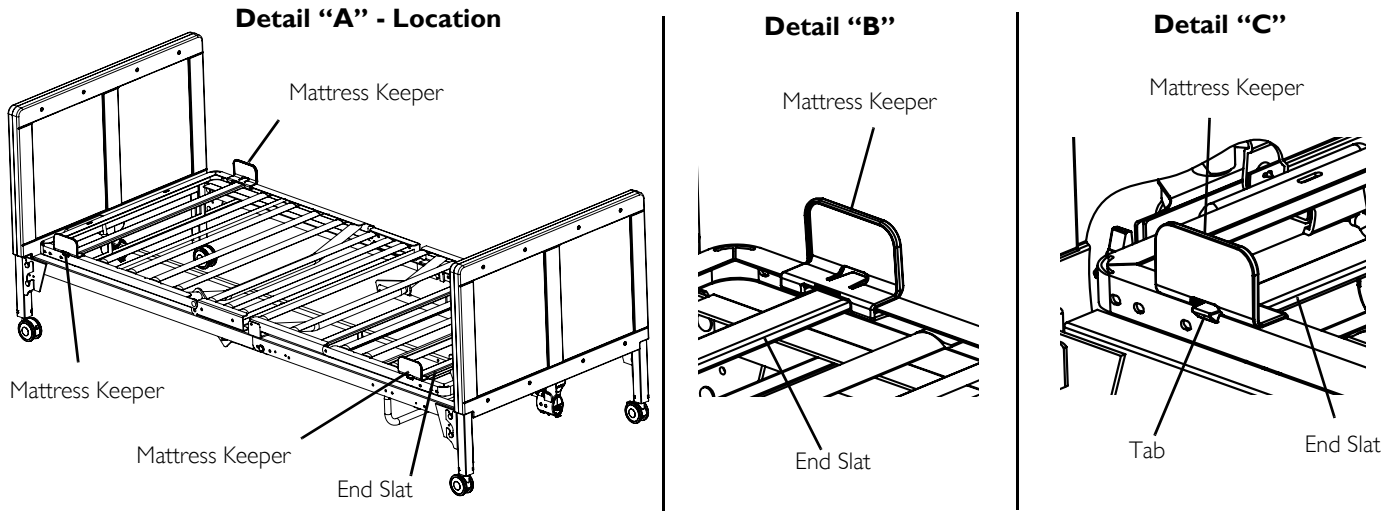

FIGURE 11 Installing/Removing Mattress Keepers

6.7 Positioning Mattress Stop for SPS1080 Mattress and SPS1084 Mattress

I. Perform one of the following:

- For SPS1080 Mattress:
 - Position the mattress stop in the UP position.
 - Position the mattress in between the headboard of the head section and the mattress stop.
- For SPS1084 Mattress:
 - Position the mattress stop in the DOWN position.
 - Position the mattress in-between the headboard of the head section and the footboard of the foot section.

6 DEALER SECTION - PACKAGING, HANDLING, AND SET-UP



For both mattresses, ensure the mattress is aligned inside the mattress keepers.

Detail "A" - Mattress Stop in UP Position

Mattress
Stop UP

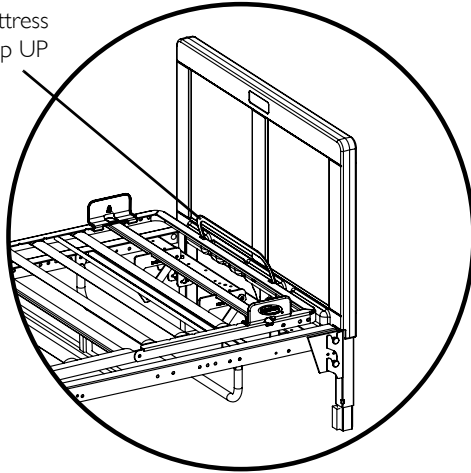

Detail "B" - Mattress Stop in DOWN Position

Mattress
Stop
DOWN

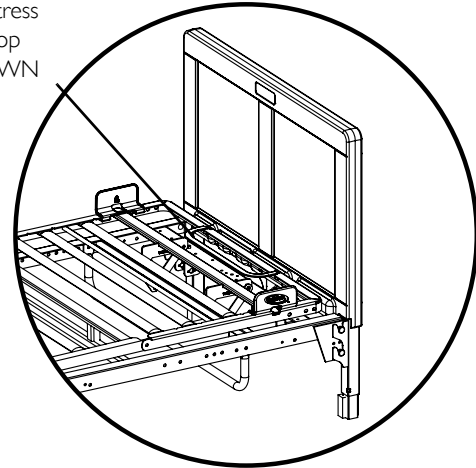

FIGURE 12 Positioning Mattress Stop for SPS1080 Mattress and SPS1084 Mattress

6 DEALER SECTION - PACKAGING, HANDLING, AND SET-UP

6.8 Connect Power Supply

1. Plug power supply into bus cable port marked power.

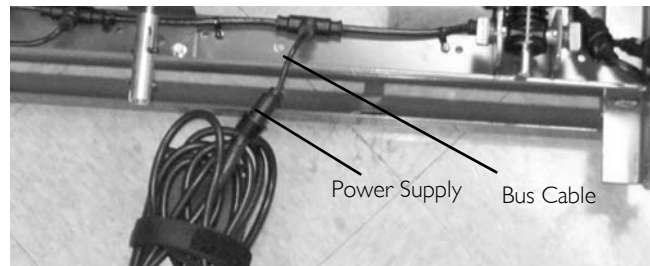

FIGURE 13 Connect Power Supply

6.9 Storing the Bed



For this procedure, refer to FIGURE 14 on page 59.

It is not necessary to disconnect power supply and pendant from the bus cable for storage.

If bed is not being assembled immediately, retain the cartons and packaging for storage until ready for assembly.

Store the bed in a dry area.



WARNING!

Risk of Injury or Damage

To avoid product damage and personal injury:

- DO NOT place other objects on top of the cartons.
- Disconnect the pendant and/or power supply when not in use and store out of reach of children.

CAUTION!

6 DEALER SECTION - PACKAGING, HANDLING, AND SET-UP

Risk of Damage

To avoid damage during transport:

- Power supply and pendant are intended to be stored on to the slat located under support brace for protection during transportation.



When performing STEP 1, the preferable slat to secure the pendant/power supply for storage is directly above the support brace. See Detail “B” in FIGURE 14.

1. Coil up pendant cable and power supply cable and secure with hook and loop provided to the underside of the slat located above the support brace bed.

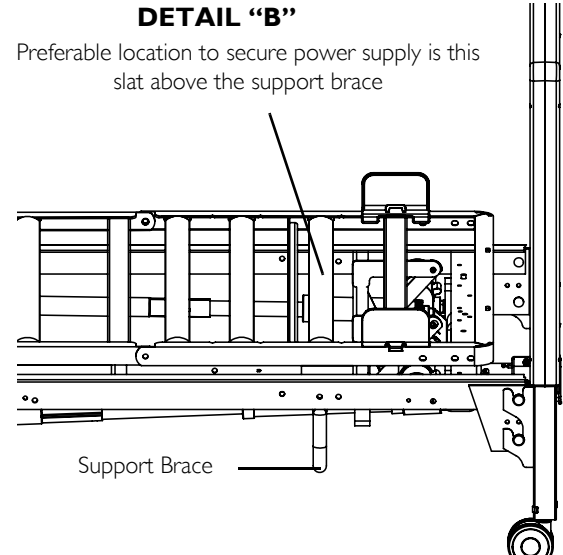
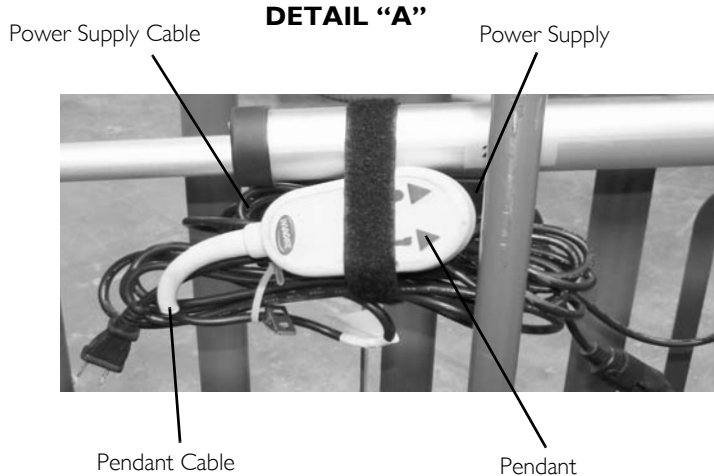

FIGURE 14 Storing the Bed

7 Troubleshooting/Maintenance - User/Dealer

7.1 Troubleshooting Electrical

SYMPTOM	PROBABLE CAUSE	USER SOLUTIONS	DEALER SOLUTIONS
<ul style="list-style-type: none"> • Electric functions do not move. 	<ul style="list-style-type: none"> • End of stroke reached. 	<ul style="list-style-type: none"> • Operate opposite button. 	<ul style="list-style-type: none"> • Operate opposite button.
	<ul style="list-style-type: none"> • Bed not plugged in. 	<ul style="list-style-type: none"> • Ensure power cord is plugged into power source. 	<ul style="list-style-type: none"> • Ensure power cord is plugged into power source. • Ensure motor and power supply are plugged into bus cable.
	<ul style="list-style-type: none"> • Pendant not functioning. 	<ul style="list-style-type: none"> • Ensure pendant cable not entangled/pinched. 	<ul style="list-style-type: none"> • Ensure pendant cable not entangled/pinched. • Ensure pendant is correctly connected to power supply. Refer to <u>Electrical Connections</u> on page 55
	<ul style="list-style-type: none"> • Cables. 	<ul style="list-style-type: none"> • Ensure cables are not entangled/pinched. • Call the dealer for repair/replacement of cables and/or motors. 	<ul style="list-style-type: none"> • Ensure motor cable(s) and power supply are correctly connected. Refer to <u>Assembling the Drive Shaft</u> on page 51. • Ensure cables are not entangled/pinched. • Call Invacare for instructions to repair/replacement of cables and/or motors.
	<ul style="list-style-type: none"> • Household fuse or breaker blown. 	<ul style="list-style-type: none"> • Check household fuse/breaker box. 	N/A

7 TROUBLESHOOTING/MAINTENANCE - USER/DEALER

SYMPTOM	PROBABLE CAUSE	USER SOLUTIONS	DEALER SOLUTIONS
<ul style="list-style-type: none"> • Bed section does not move. 	<ul style="list-style-type: none"> • Broken connector cap. 	<ul style="list-style-type: none"> • Call dealer. 	<ul style="list-style-type: none"> • Call Invacare for instructions to replace connector cap.
	<ul style="list-style-type: none"> • Motors are not functioning. 	<ul style="list-style-type: none"> • Call dealer. 	<ul style="list-style-type: none"> • Check to make sure nothing is blocking actuator.
	<ul style="list-style-type: none"> • Hi/Lo Motor not functioning. 	<ul style="list-style-type: none"> • Ensure cables are not entangled or pinched. • Call dealer. 	<ul style="list-style-type: none"> • Ensure cables are not entangled or pinched. • Ensure Drive Shaft is correctly installed. • Ensure Hi/Lo Motor cable is correctly connected. Refer to <u>Assembling the Drive Shaft</u> on page 51.
	<ul style="list-style-type: none"> • Thermal Protection Activated. 	<ul style="list-style-type: none"> • Allow bed unit to sit for up to 30 minutes and retry. 	<ul style="list-style-type: none"> • Allow bed unit to sit for 30 minutes and retry.
<ul style="list-style-type: none"> • Bed section does not stop moving. 	<ul style="list-style-type: none"> • Pendant. 	<ul style="list-style-type: none"> • Check for depressed/stuck buttons. If button is stuck, call dealer for repair. Unplug power cord from the wall. 	<ul style="list-style-type: none"> • Replace pendant. Refer to <u>Electrical Connections</u> on page 55.
<ul style="list-style-type: none"> • Bed Hi/Lo movement does not stop. 	<ul style="list-style-type: none"> • Defective Pendant. • Damaged Cables. 	<ul style="list-style-type: none"> • Check cables, if damaged call dealer. 	<ul style="list-style-type: none"> • Check cables, if damaged, replace. Refer to <u>Assembling the Drive Shaft</u> on page 51.

7 TROUBLESHOOTING/MAINTENANCE - USER/DEALER

SYMPTOM	PROBABLE CAUSE	USER SOLUTIONS	DEALER SOLUTIONS
<ul style="list-style-type: none"> • Bed is producing unusual sounds, burning odors, or movement deviations observed in the controls, motors, or the limits switch functions. 	<ul style="list-style-type: none"> • Electrical Component Error. 	<ul style="list-style-type: none"> • Unplug power cord from the wall. Call Dealer. 	<ul style="list-style-type: none"> • Call Invacare for instructions.
<ul style="list-style-type: none"> • Intermittent motor operation. 	<ul style="list-style-type: none"> • Pushing button too quickly. 	<ul style="list-style-type: none"> • Allow a slight pause between adjustments and avoid pressing multiple buttons at the same time. If pendant buttons are depressed too rapidly or multiple buttons are pressed at the same time, the desired feature may not activate. Simply release the pendant button, permit a slight pause and then activate the next operation. 	<ul style="list-style-type: none"> • Call Invacare for instructions.

7.2 Troubleshooting Mechanical

SYMPTOM	PROBABLE CAUSE	USER SOLUTIONS	DEALER SOLUTIONS
<ul style="list-style-type: none"> • Bed does not stay in place. 	<ul style="list-style-type: none"> • Casters unlocked. 	<ul style="list-style-type: none"> • Lock Casters. 	<ul style="list-style-type: none"> • Lock Casters.
	<ul style="list-style-type: none"> • Locking Caster not installed properly. 	<ul style="list-style-type: none"> • Call Dealer. 	<ul style="list-style-type: none"> • Ensure locking casters are installed properly. Refer to Assembling the Bed Ends on page 49.

7 TROUBLESHOOTING/MAINTENANCE - USER/DEALER

SYMPTOM	PROBABLE CAUSE	USER SOLUTIONS	DEALER SOLUTIONS
<ul style="list-style-type: none"> • Bed sections do not move. 	<ul style="list-style-type: none"> • Pull tube. 	<ul style="list-style-type: none"> • Check pull tube(s) for binding. Call dealer for repairs. 	<ul style="list-style-type: none"> • Ensure pull tubes are properly connected. Refer to <u>Adjusting and Reconnecting the Head Section Pull Tube</u> on page 47.
<ul style="list-style-type: none"> • Bed ends move in opposite directions. 	<ul style="list-style-type: none"> • Drive Shaft connected to wrong gear box shaft. 	<ul style="list-style-type: none"> • Call dealer. 	<ul style="list-style-type: none"> • Reinstall Drive Shaft. Refer to <u>Assembling the Drive Shaft</u> on page 51.
<ul style="list-style-type: none"> • Hi/Lo function does not work. 	<ul style="list-style-type: none"> • Drive Shaft disconnected. 	<ul style="list-style-type: none"> • Call dealer. 	<ul style="list-style-type: none"> • Reinstall Drive Shaft. Refer to <u>Assembling the Drive Shaft</u> on page 51.
<ul style="list-style-type: none"> • Pressing function on pendant results in motion other than that intended. 	<ul style="list-style-type: none"> • Motor cable connections are incorrect. 	<ul style="list-style-type: none"> • Call dealer. 	<ul style="list-style-type: none"> • Verify Connections. Refer to <u>Inspecting the Bed</u> on page 54.



For access to part numbers, see online parts book at www.invacare.com or call Invacare.

8 MAINTENANCE AND CLEANING

8 Maintenance and Cleaning



WARNING!

Risk of Injury or Damage

To avoid injury or damage from misuse:

- Read all general guidelines, warnings and cautions before performing any repair/maintenance on the bed.
- All repair and maintenance on the bed should be performed by a qualified technician.

Invacare recommends the following maintenance/cleaning procedures be conducted initially, between users or as needed. This form is provided as a guide to help with documentation.

8.1 Maintenance Checklist

Mechanical Inspection and Maintenance	Electrical Inspection and Maintenance
<input type="checkbox"/> Inspect rail latches. Ensure that all rails engage and lock as specified.	<input type="checkbox"/> Inspect for damaged or loose wiring. Have a qualified technician replace any frayed or damaged cords.
<input type="checkbox"/> Lubricate rail pivot points and all mechanical hinge points, bushings, and surface contact points as needed with white lithium grease.	<input type="checkbox"/> Inspect all electrical bed components for damage or excessive wear (i.e. cracked or broken housings, or worn components).
<input type="checkbox"/> Inspect bed, rails, assist rails, or assist bars for the presence of tubing end caps and replace as required.	<input type="checkbox"/> Check pendant, power and motor cords for chafing, cuts or excessive wear.
<input type="checkbox"/> Inspect all bed components (i.e. rails, clevis pins, hitch pins, etc...) for damage or excessive wear and replaced as necessary.	<input type="checkbox"/> Make sure all plugs are fully attached and free of damage.
<input type="checkbox"/> Visually examine all welds for cracks.	<input type="checkbox"/> Make sure all connectors are properly positioned and locked.
<input type="checkbox"/> Inspect the head and foot sections for bending, warping or damage.	

8 MAINTENANCE AND CLEANING

Mechanical Inspection and Maintenance	Electrical Inspection and Maintenance
<input type="checkbox"/> Inspect all bolts and rivets to ensure that they are securely tightened and functioning properly.	<input type="checkbox"/> Check all functions: 1. Head raises and lowers properly. 2. Foot raises and lowers properly. 3. Bed ends raise and lower properly.
<input type="checkbox"/> Check sleep surfaces to ensure all slats are intact.	
<input type="checkbox"/> Check casters to ensure they lock, if applicable, and roll properly.	

Pass/Fail

- PASS: Bed and all components have passed all of the above inspection criteria and the bed is ready for placement into a client's home.
- FAIL: Bed, or any component, has failed any of the above inspection criteria. Tag the bed or component with a complete description of the failure(s) and have the bed serviced.

8.2 Cleaning the Beds



WARNING!

Risk of Injury or Damage

To avoid injury or damage from liquid ingress during maintenance:

- DO NOT spray water into any power supply connection ports.
- The electronic motors, power supply and pendants are protected against the entrance of dust and water when properly attached.
- Before disassembling or washing an electric bed, disconnect the power supply from the electrical outlet.

8 MAINTENANCE AND CLEANING

Washing the Bed

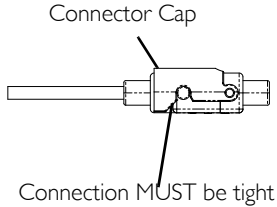

1. Before cleaning the bed, perform the following:
 - Ensure that the pendant cable, port cover, motor, actuators, and power supply are securely connected to the bus cable.
 - Ensure connector cap on all connections is lowered to lock connection in place.



2. Disconnect the power supply of the bed from the electrical outlet before washing.
3. Make sure all electrical parts are not damaged and that all connection ports are plugged.
4. Remove the head and foot boards. Refer to [Installing/Removing the Bed Ends](#) on page 49.
5. Inspect bed components for any exposed metal. To prevent rusting, Invacare recommends covering those areas with touch-up paint.
6. Disinfect and wash all components and exterior surfaces using a mild soap/detergent and soft bristle brush or sponge. **DO NOT** submerge the bed frame or electrical parts.





7. Using household water pressure only, rinse thoroughly with water (maximum temperature 110° F or 43° C). DO NOT power wash or steam clean. DO NOT use solvents, bleach, alcohol, petroleum products, caustic agents, or highly alkaline or acidic agents to clean the bed.

Drying the Bed

CAUTION!

Risk of Damage

To protect flooring from damage or staining, perform the following:

- Ensure bed ends are completely drained and dry before placing on flooring.



DANGER!

Risk of Injury or Death

To prevent a fall or fire:

- Inspect bed ends for leaking grease.
- Contact service provider if grease or other residue is detected.



1. Tip the bed from side to side to allow any collected or trapped water to drain.
2. Thoroughly towel dry bed and all components.
3. Repeat drying process until all components are dry.



Ensure that the bed is completely dry before storing.

Making Life's Experiences Possible[®]



Part No 1180159-E

8/22/2018



Invacare Corporation

USA
One Invacare Way
Elyria, Ohio USA
44035
800-333-6900

www.invacare.com



Yes, you can.