



JOHN DEERE

OPERATOR'S MANUAL

**Front Mounted Thatcher
38 Inch
LP48004**

**8 Inch Extension Kit - LP48003
Mounting Kit - LP48005**

**M154810-B
10 / 11 / 2021
English**

Introduction

Using Your Operator's Manual

Read this entire operator's manual, especially the safety information, before operating.

This manual is an important part of your machine. Keep all manuals in a convenient location so they can be accessed easily.

Use the safety and operating information in the attachment operator's manual, along with the machine operator's manual, to operate and service the attachment safely and correctly.

If your attachment manual has a section called Preparing the Machine, it means that you will have to do something to your tractor or vehicle before you can install the attachment. The Assembly and Installation sections of this manual provide information to assemble and install the attachment to your tractor or vehicle. Use the Service section to make any needed adjustments and routine service to your attachment.

If you have any questions or concerns with the assembly, installation, or operation of this attachment, see your local John Deere dealer.

Warranty information on this John Deere attachment can be found in the warranty statement included in this manual.

LP48004
+ LP48003
+ LP48005

Product Compatibility

Front Mounted Thatcher designed for X300 and X500 Series Tractors

Original instructions. All information, illustrations and specifications in this manual are based on the latest information available at the time of publication. The right is reserved to make changes at any time without notice.

Table of Contents

Introduction	2
Safety	3 - 4

Parts & Assembly

38" & 54" Thatcher	6 - 7
46" Thatcher	8 - 9
8" Extension Kit	10-11
Mounting Kit	12-13

Use and Care

Installing / Removing	15-19
Storing	19
Operation	20 - 25
Service	26
Troubleshooting	27

Warranty	28
----------------	----

Record Product Information

In the event that you need to contact an Authorized Service Center for information on servicing your product, record the following information in the spaces provided below.

DATE OF PURCHASE:

DEALER NAME:

DEALER PHONE:

Safety

Read the general safety operating precautions in your machine operator's manual for additional safety information.

Safety Labels

Understanding the Machine Safety Labels



The machine safety labels shown in this section are placed in important areas on your machine to draw attention to potential safety hazards.

On your machine safety labels, the words DANGER, WARNING, and CAUTION are used with this safety-alert symbol. DANGER identifies the most serious hazards.

The operator's manual also explains any potential safety hazards whenever necessary in special safety messages that are identified with the word, CAUTION, and the safety-alert symbol.

CAUTION: Help Avoid Injury



CAUTION

HELP AVOID INJURY
Read operator's manual
Make sure the safety rods are
securely in place before operating.

- Read operator's manual.
- Make sure the safety rods are securely in place before operating.

MX57684

Operate Safely

- Read the machine and attachment operator's manual carefully. Be thoroughly familiar with the controls and the proper use of the equipment. Know how to stop the machine and disengage the controls quickly.
- This attachment is intended for use in lawn care and home applications. Do not use for use other than intended by the manufacturer.
- Do not modify machine or safety devices. Unauthorized modifications to the machine or attachment may impair its function and safety.
- Do not let children or an untrained person operate machine.
- Make any necessary adjustments before you operate. Never attempt to make any adjustments while the engine is running, unless if recommended in adjustment procedure.
- Look behind machine before backing up carefully.
- Do not let anyone, especially children, ride on machine or attachment. Riders are subject to injury such as being struck by foreign objects and being thrown off. Riders may also obstruct the operator's view, resulting in the machine being operated in an unsafe manner.
- Disengage any power to the attachment when the machine is transported or not in use.

Practice Safe Maintenance

- Only qualified, trained adults should service machine.
- Understand service procedure before doing work. Keep area clean and dry.
- Do not operate the engine in a confined space where dangerous carbon monoxide fumes can collect.
- Never lubricate, service or adjust the machine or attachment while it is moving. Keep safety devices in place and in working condition. Keep hardware tight.
- Keep hands, feet, clothing, jewelry, and long hair away from any moving parts, to prevent them from getting caught.

Safety / Specifications

Practice Safe Maintenance, cont.

- Disconnect battery or remove spark plug wire (for gasoline engines) before making any repairs.
- Keep all parts in good condition and properly installed. Fix damage immediately. Replace worn or broken parts. Replace all worn or damaged safety and instruction decals.
- Check all hardware at frequent intervals to be sure the equipment is in safe working condition.
- Do not modify machine or safety devices. Unauthorized modifications to the machine or attachment may impair its function and safety.

Wear Appropriate Clothing

- Always wear eye protection when operating the machine.
- Wear close fitting clothing and safety equipment appropriate for the job.
- While mowing, always wear substantial footwear and long trousers. Do not operate the equipment when barefoot or wearing open sandals.
- Wear a suitable protective device such as earplugs. Loud noise can cause impairment or loss of hearing.



Specifications

38 in. Thatcher Specifications

MAIN FRAME

Construction 11 Gauge Steel
Size 21 x 101.6 cm (8-1/4 x 40 in.)
Working Width 96.5 cm (38 in.)
Weight 25 kg (55 lb)

GAUGE WHEEL

Width 44 mm (1-3/4 in.)
Diameter 20.3 cm (8 in.)
Wheel Bearing Material Iron, Oil
Impregnated

TINES

Number 10 Double End
Diameter 4.8 mm (3/16 in.)

(Specifications and design subject to change without notice).



JOHN DEERE

ASSEMBLY SECTION

Front Mounted Thatcher & Kits

38 & 54 Inch Thatchers	6-7
46 Inch Thatcher	8-9

KITS

8 inch Frame Extension	10-11
Thatcher Mounting Kit	12-13

Assembly

► Thatcher, 38 and 54 in.

Parts:

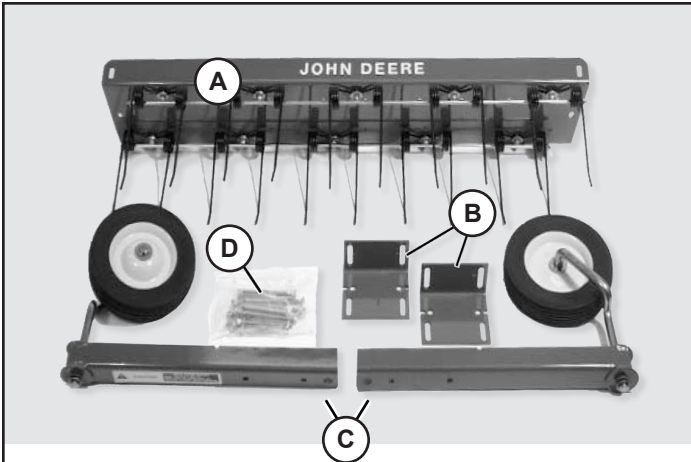

Ref.	Description	Qty.
(A)	Main Frame	1
(B)	Frame Mounting Brackets	2
(C)	Gauge Wheel Assemblies	2
(D)	BAG OF PARTS:	1
(E)	- Carriage Bolt, 5/16 x 4 in.	4
(F)	- Carriage Bolt, 5/16 x 1 in.	4
(G)	- Locknut, 5/16 in.	8
(H)	- Spacer, 3-1/4 in.	4

Note:



CAUTION: Avoid Injury!
TINES ARE SHARP

Wear heavy gloves when working around tines and do not work under raised attachment unless it is safely supported.

Step 1-A. Attach Mounting Brackets

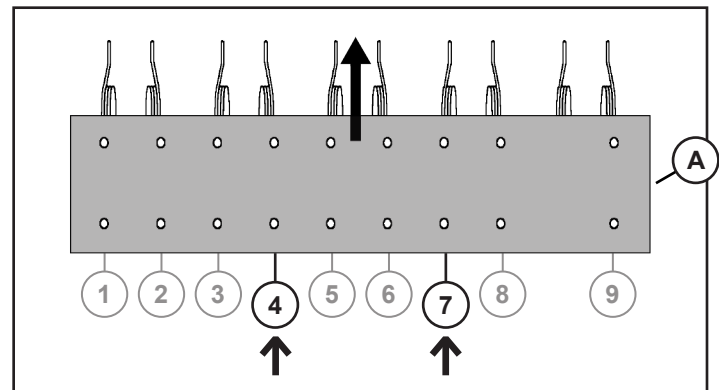

IMPORTANT: Avoid damage!

Tips of tines must face direction of forward travel.

1. Locate frame (A) mounting bracket mounting holes 4 and 7.

Assembly

Step 1-B. Attach Mounting Brackets

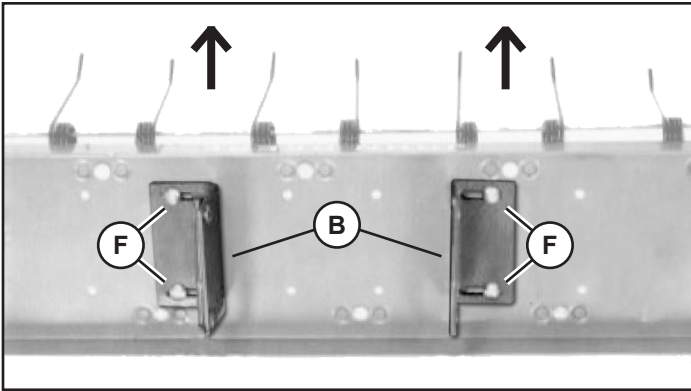

2. Attach frame mounting brackets (**B**). Long side of each bracket must face toward outside of frame as shown.
3. Install four 5/16 x 1 in. carriage bolts (**F**) and locknuts (**G**). Do not tighten completely.

Step 2-A. Attach Wheel Assemblies

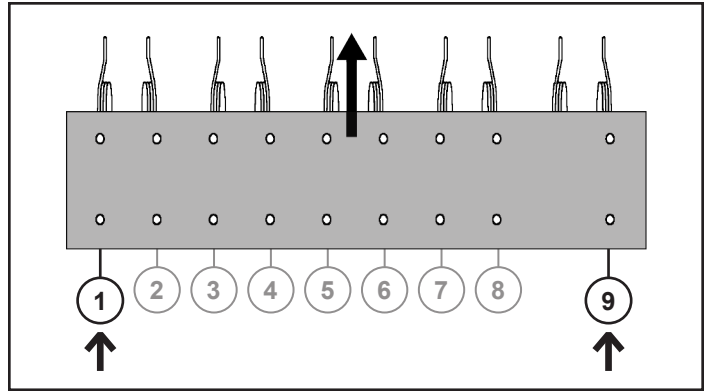

1. Locate wheel support bracket mounting 1 and 9.

Step 2-B. Attach Wheel Assemblies

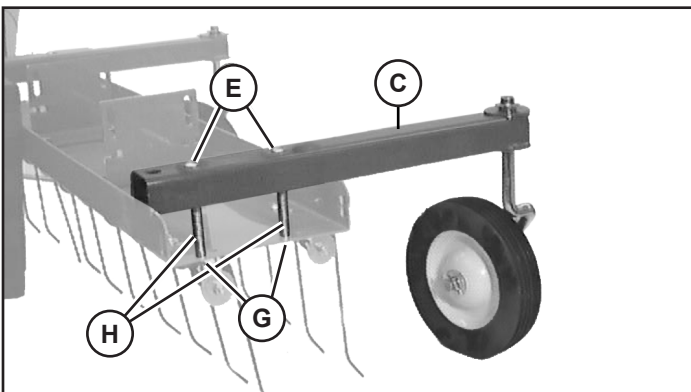

2. Fasten wheel supports (**C**) to main Thatcher frame using four 5/16 x 4 in. carriage bolts (**E**), pipe spacers (**H**), and locknuts (**G**).
3. Tighten nuts completely.

Next Steps:

Continue to page 10 for the 8" Extension Kit Assembly Steps

or

Continue to page 12 for the Thatcher Mounting Kit Assembly Steps

NOTE: Use and Care section begins on page 14.

Assembly

► Thatcher, 46 in.

Parts:

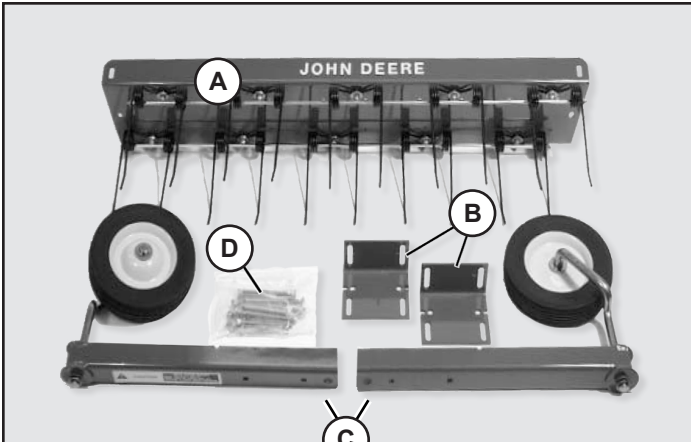

Ref.	Description	Qty.
(A)	Main Frame	1
(B)	Frame Mounting Brackets	2
(C)	Gauge Wheel Assemblies	2
(D)	BAG OF PARTS:	1
(E)	- Carriage Bolt, 5/16 x 4 in.	4
(F)	- Carriage Bolt, 5/16 x 1 in.	4
(G)	- Locknut, 5/16 in.	8
(H)	- Spacer, 3-1/4 in.	4

Note:



CAUTION: Avoid Injury!
TINES ARE SHARP

Wear heavy gloves when working around tines and do not work under raised attachment unless it is safely supported.

Step 1-A. Attach Mounting Brackets

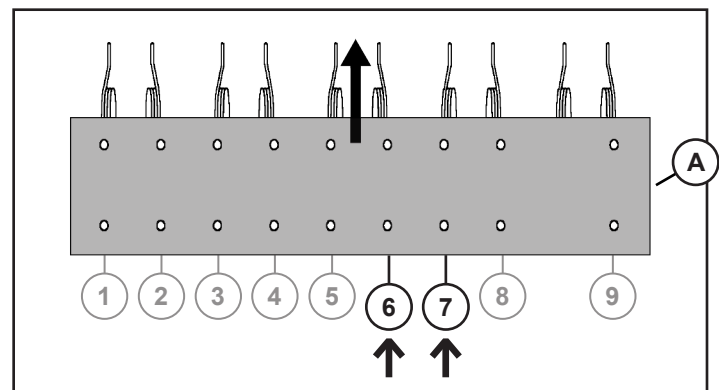

IMPORTANT: Avoid damage!

Tips of tines must face direction of forward travel.

1. Locate frame (A) mounting bracket mounting holes 6 and 7.

Assembly

Step 1-B. Attach Mounting Brackets

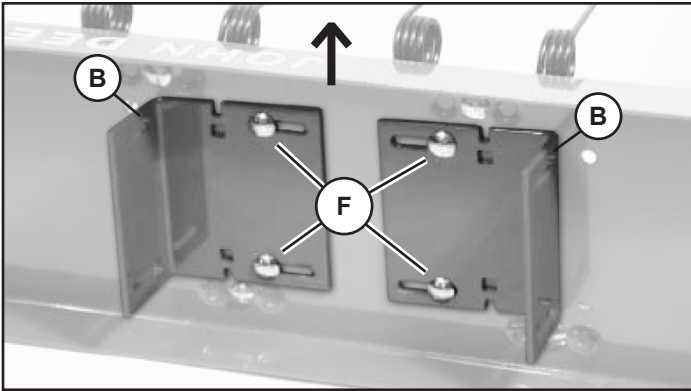

2. Attach frame mounting brackets (**B**). Long side of each bracket must face toward outside of frame as shown.
3. Install four 5/16 x 1 in. carriage bolts (**F**) and locknuts (**G**). Do not tighten completely.

Step 2-A. Attach Wheel Assemblies

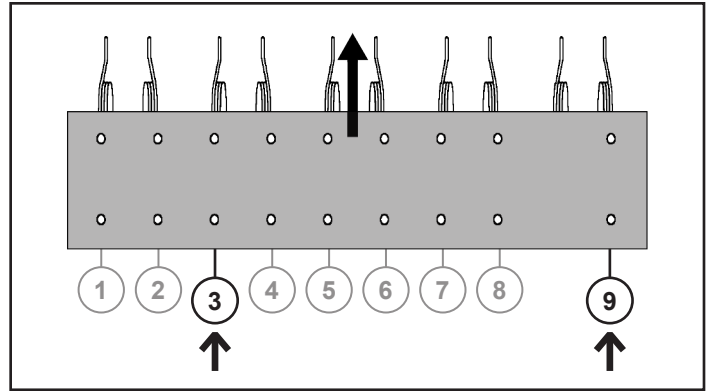

1. Locate wheel support bracket mounting 3 and 9.

Step 2-B. Attach Wheel Assemblies

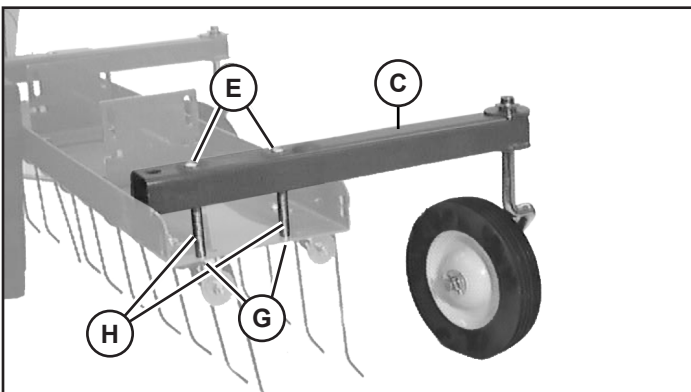

2. Fasten wheel supports (**C**) to main Thatcher frame using four 5/16 x 4 in. carriage bolts (**E**), pipe spacers (**H**), and locknuts (**G**).
3. Tighten nuts completely.

Next Steps:

Continue to page 10 for the 8" Extension Kit Assembly Steps

or

Continue to page 12 for the Thatcher Mounting Kit Assembly Steps

NOTE: Use and Care section begins on page 14.

Assembly

► 8 Inch Frame Extension Kit, 46 & 54 in.

Parts:

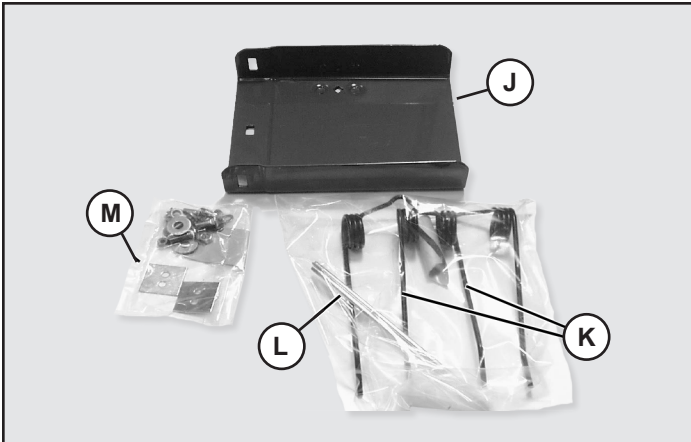

Ref.	Description	Qty.
(J)	Extension	1
(K)	Tine	2
(L)	Tine Retention Safety Rod	2
(M)	Bag of Parts:	1
(N)	- Washer, Two-Hole	2
(O)	- Carriage Bolt, 5/16 x 3/4 in.	3
(F)	- Carriage Bolt, 5/16 x 1 in.	2
(P)	- Locknut, 1/4 in.	4
(Q)	- Hex Nut, 5/16 in.	5
(R)	- Lockwasher, 5/16 in.	5
(S)	- Washer, 0.344 x 0.688 x 0.065 in.	3
(T)	- Washer, 9 x 29 x 3 mm	2

NOTE: Thatcher Frame Extensions are used for increasing the thatching width for the 38 in. thatcher, creating the 46 and 54 in. thatchers.

- 46 in. thatcher requires one frame extension.
- 54 in. thatcher requires two frame extensions.

Note:

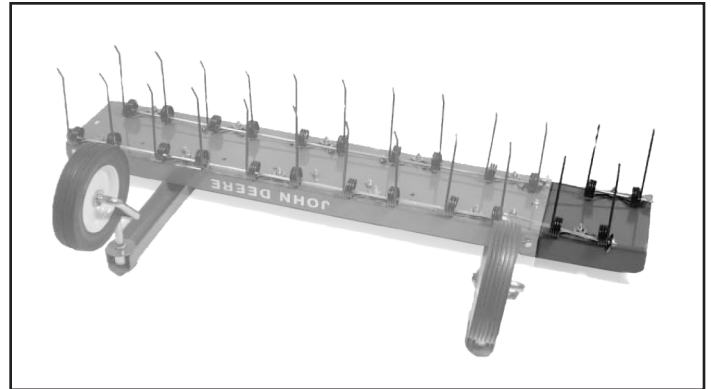

Picture Note: Finished 46-inch thatcher with one extension installed on right side of main thatcher frame.

⚠ CAUTION: Avoid Injury! Tines are sharp.
Wear heavy gloves when working around tines and do not work under raised attachment unless it is safely supported.

Step.1.

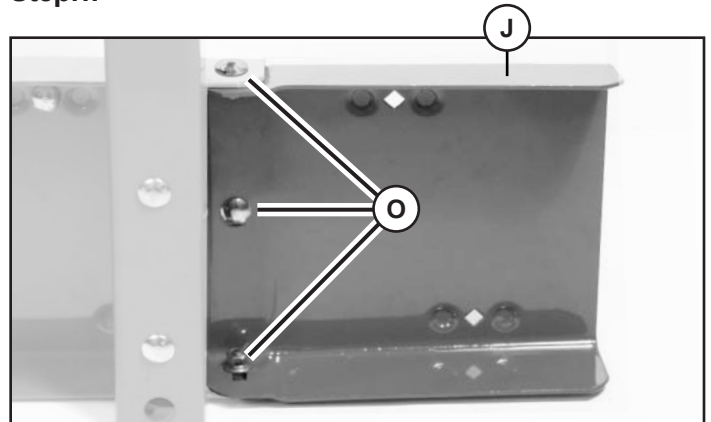

1. Install frame extension (J) on right side of main frame using three 5/16 x 3/4 in. carriage bolts (O) through main frame and extension, then 0.344 x 0.688 washers (S), lock washers (R) and 5/16 in. hex nuts (Q).

Tighten nuts completely.

Assembly

Step 2.

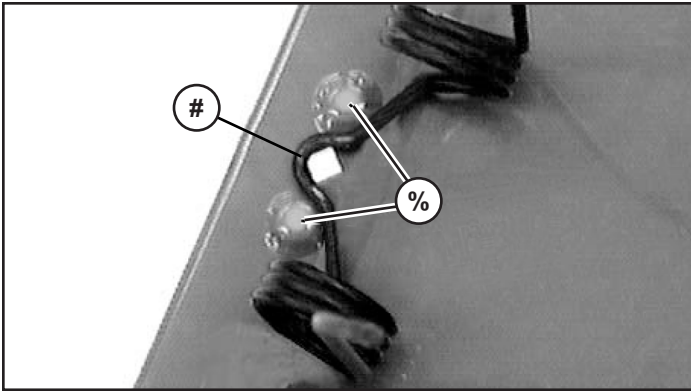

2. Position the offset (#) in line between two frame extrusions (%).

Steps 3 & 4.

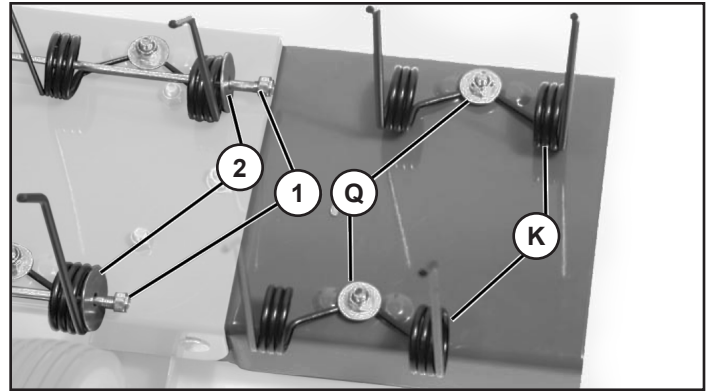

3. Attach two tines (K) to extension with tine tips facing same direction as tine tips in main frame.
Fasten with two 5/16 x 1 in. carriage bolts (F), 9 x 29 x 3 mm washers (T), lock washers (R) and 5/16 in. hex nuts (Q). Tighten nuts completely.
4. Remove and retain locknuts (1) and washers (2) from main frame tine retention rods.

Step 5.

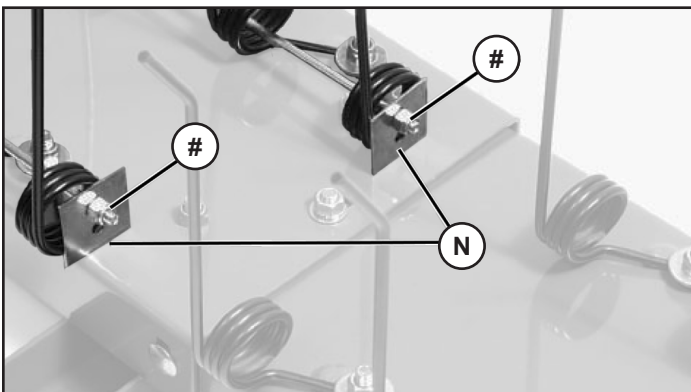

5. Install two-hole washers (N) onto main retention rods. Fasten with the lock nuts (1) that were removed on Step 4.

Steps 6 & 7.

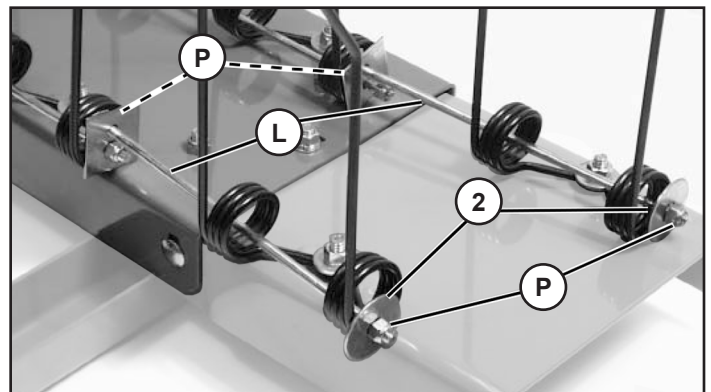

6. Place short retention rods (L) through tines and secure in two-hole washers with 1/4 in. locknuts (P).
7. Install the washers (2) that were removed on Step 4, on the other end of short retention rods. secure with 1/4 in. locknuts (P).

Assembly

► Thatcher Mounting Kit

Parts:

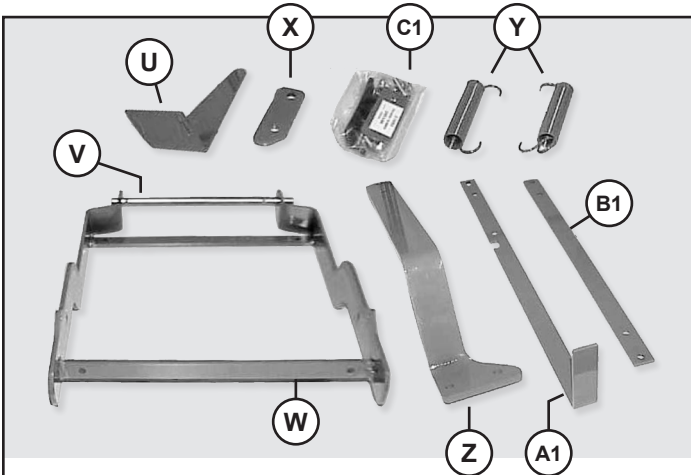

Ref.	Description	Qty.
(U)	Bracket, Lift Handle	1
(V)	Rod, Mounting	1
(W)	Mounting Frame	1
(X)	Strap, Spacer	1
(Y)	Lift Spring	2
(Z)	Extension, Lift Lock	1
(A1)	Lift Handle, Upper	1
(B1)	Lift Handle, Lower	1
(C1)	Bag of Parts:	1
(F)	- Carriage Bolt, 5/16 x 1 in.	8
(D1)	- Carriage Bolt, 5/16 x 1-1/4 in.	1
(E1)	- Screw, M10 x 30	2
(Q)	- Hex Nut, 5/16 in.	8
(G)	- Locknut, 5/16 in.	1
(F1)	- Nut, M10	2
(R)	- Lockwasher, 5/16 in.	8
(S)	- Washer, 0.344 x 0.688 x 0.065 in.	4
(G1)	- Spring Locking Pin	2
(H1)	- Pin, Drilled (Short) (5/16 x 3/4 in.)	1
(J1)	- Pin, Drilled (Long) (5/16 x 1-1/4 in.)	1
(K1)	- Bracket, Lock	1
(L1)	- Handle Grip	1
(M1)	- Spacer, 1/2 in. long	1

Note:



CAUTION: Avoid Injury! TOUCHING HOT SURFACES CAN BURN SKIN.

The engine, components, and fluids will be hot if the engine has been running. Keep hands and body away from hot surfaces when servicing or working near the engine and components.

Step 1.

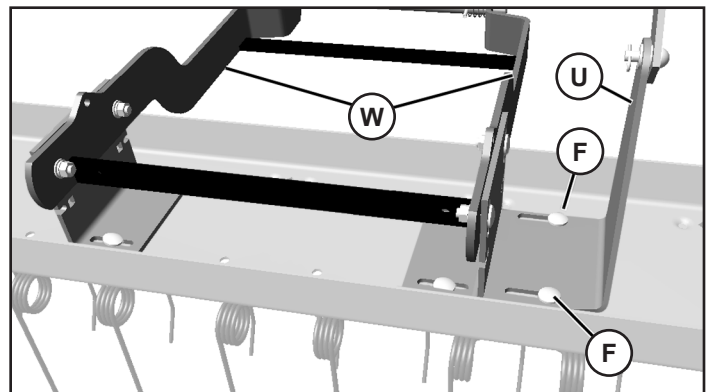

1. Position lift handle bracket (U) over holes next to frame mounting bracket (W) on left side of thatcher. Make sure lift handle bracket faces direction shown. Install two 5/16 x 1 in. carriage bolts (F), lockwashers (R), and hex nuts (Q). Do not tighten completely.

Assembly

Step 2.

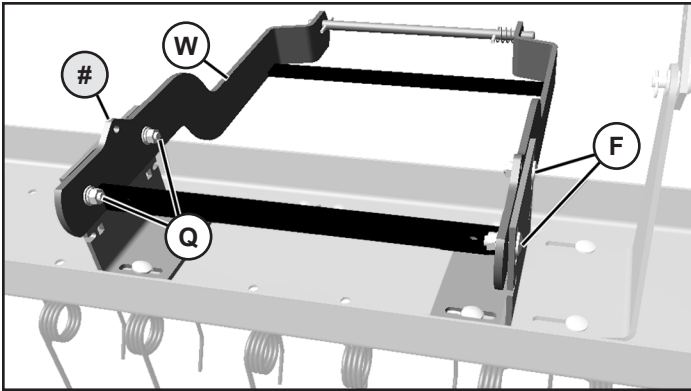

2. Attach mounting frame (W) to frame mounting brackets with four 5/16 x 1 in. carriage bolts (F), lockwashers (R), and hex nuts (Q). Mounting frames and frame mounting brackets should be aligned so hole in notch (#) is visible as shown. Tighten nuts completely to ease in assembly; nuts will be loosened later for leveling procedure.

Step 3.

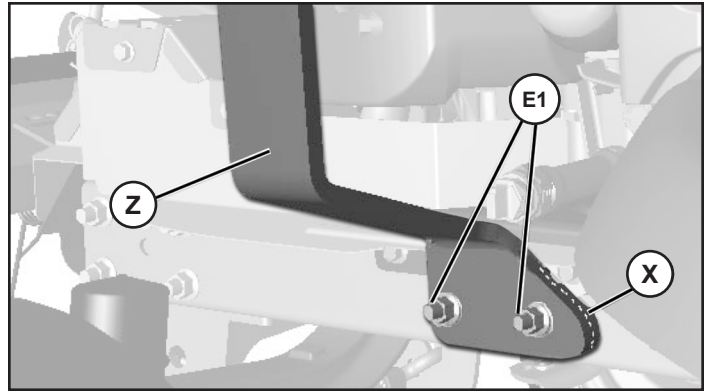

3. Install lift lock extension (Z) and spacer strap (X) using existing holes in left side of tractor frame. Secure with two M10 x 30 flange bolts (E1) and M10 serrated hex nuts (F1). Tighten nuts completely. *As nuts are tightened the heat shield will form up to proper position.*

Steps 4 & 5.

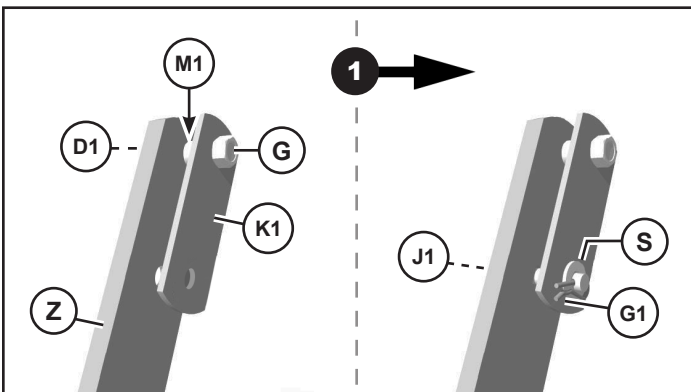

NOTE: Front of tractor indicated by (1).

4. Assemble lock bracket (K1) to the lift lock extension (Z) and secure with a 5/16 x 1-1/4 in. carriage bolt (D1), spacer (M1), and locknut (G).
5. Insert the long drilled pin (5/16 x 1-1/4 in.) (J1) in lower hole; add washer (S) and secure with spring locking pin (G1).

Next Steps:

Continue to the installation section on page 15.
The remaining parts in this kit are used to attach the dethatcher:

Ref.	Description	Qty.
V	Rod, Mounting	1
Y	Lift Spring	2
A1	Lift Handle, Upper	1
B1	Lift Handle, Lower	1
F	Carriage Bolt, 5/16 x 1 in.	2
Q	Hex Nut, 5/16 in.	2
R	Lockwasher, 5/16 in.	2
S	Washer, 0.344 x 0.688 x 0.065 in.	3
G1	Spring Locking Pin	1
H1	Pin, Drilled (Short) (5/16 x 3/4 in.)	1
L1	Handle Grip	1

Use and Care

38" Front Mounted Thatcher



LP48004

Installing / Removing 15-19

Storing 19

Operation

- *What is Thatcher?* 20

- *When to Use Thatcher* 20

- *Lift Handle & Gauge Wheels* 21

- *Adjusting Tines* 21

- *Leveling Thatcher* 22 - 23

- *Centering Thatcher* 24

- *Checking Tines & Transport Mode* 25

- *Service* 26

- *Troubleshooting* 27

Quality 27

Warranty 28

This product was manufactured by Brinly-Hardy Co., a John Deere Licensee, located at 3230 Industrial Pkwy, Jeffersonville, IN 47130. If you have any questions or concerns with the assembly, installation or operation of this attachment see your local John Deere Dealer or call Brinly-Hardy Co. at 866-218-8622 for assistance.



Installing

Steps 1 & 2.

CAUTION: Avoid Injury! TOUCHING HOT SURFACES CAN BURN SKIN.

The engine, components, and fluids will be hot if the engine has been running. Keep hands and body away from hot surfaces when servicing or working near the engine and components.

1. Park machine safely.
(See *Parking Safely* in the **SAFETY** section).
2. Align thatcher mounting frame with mounting bracket at front of tractor.

Step 3.

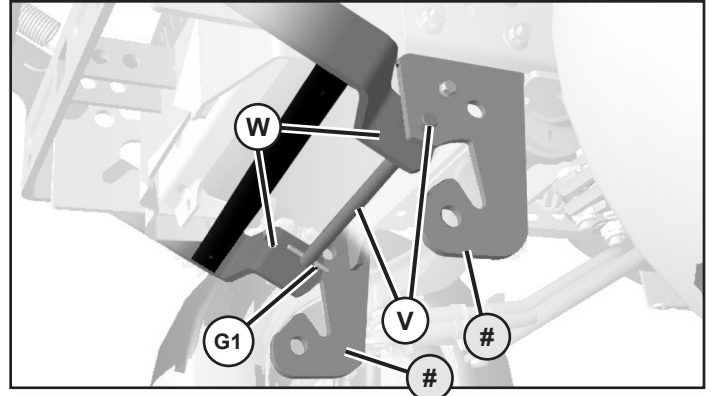

3. Install mounting rod (V) through mounting brackets (#) and through frame (W).
 - Pull back on spring pin (G1) and place opposite end through mounting frame and tractor frame.
 - With the spring pulled back insert that end through the other side of tractor through mounting frame and tractor frame.

Step 4.

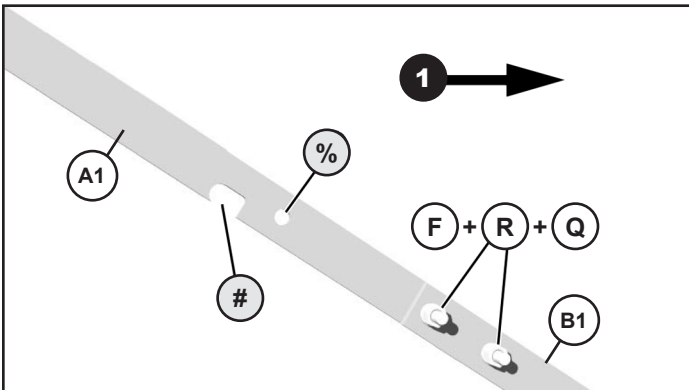

NOTE: Notch (#) in lift handle must face downward. For transporting use hole (%). Front of tractor indicated by (1).

4. Attach lower lift handle (B1) to upper lift handle (A1) with two 5/16 x 1 in. carriage bolts (F), lockwashers (R), and hex nuts (Q). Tighten nuts completely and add the handle grip (L1) on the end.

Step 5.

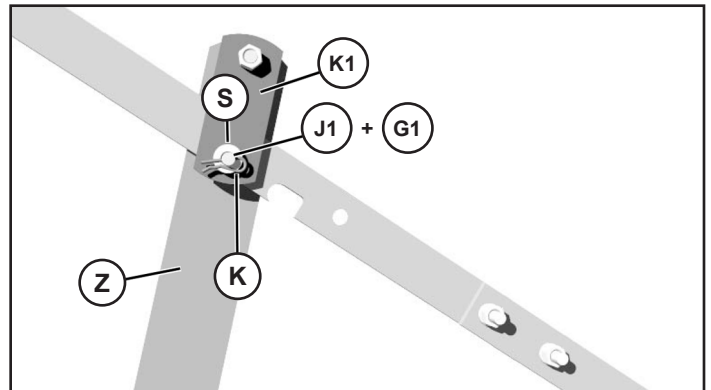

5. Remove spring locking pin (G1), washer (S), and drilled pin (J1). Next, slide lift handle between lift lock extension (Z) and lock bracket (K1).
Re-install the drilled pin (J1), washer (S) and secure with spring locking pin (G1).

Installing

Step 6.

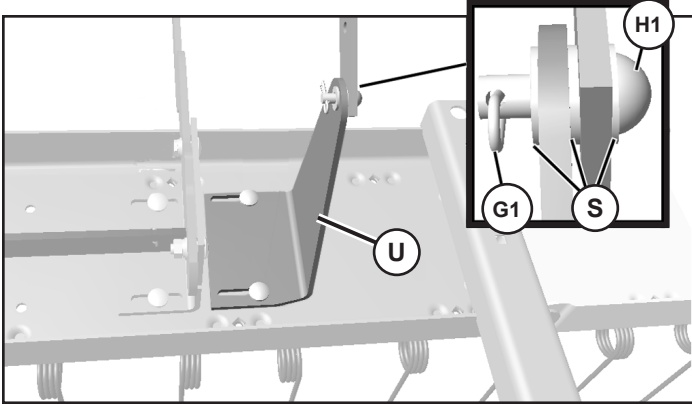

6. Attach lift handle to lift handle bracket (U) with three 0.344 x 0.688 x 0.065 in. washers (S), drilled pin (H1), and clip pin (G1).

Install Springs (X300 Select Series)

* for X500 Select Series, skip to Step 11-A on pg 17.

Step 10-A.

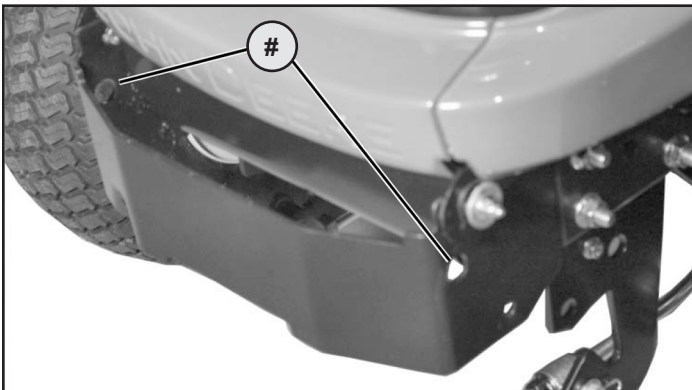

CAUTION: Avoid Injury! Springs are under tension. Hold firmly during removal and installation. Wear eye protection.

NOTE: The thatcher must be in the transport position to install springs. Hook the end without the finger pull loop to the front bracket (#) on the tractor.

Steps 7-9.

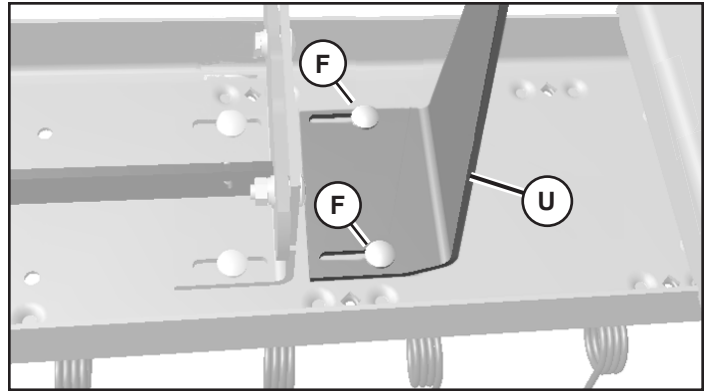

7. Align bracket (U) so lift handle remains straight as it leaves lift lock extension mounted at tractor frame. Tighten carriage bolt (F) hardware completely.
8. Lift and lock thatcher in transport position.
9. Level and center the thatcher. (See *Level and Center Thatcher in the Operating Section.*)

Step 10-B.

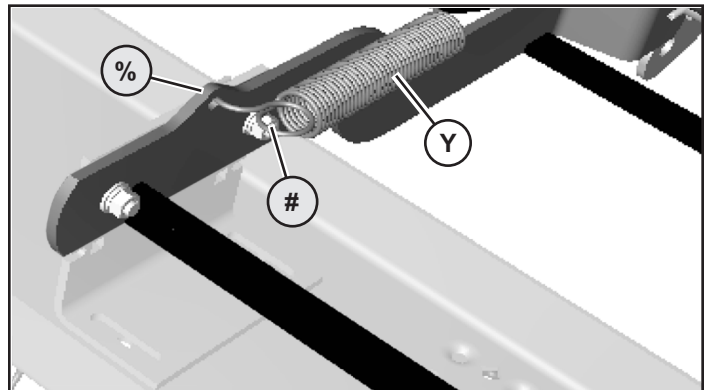

Pull the spring (Y) using the finger pull loop (#) to the bump hole (%) on the lift bracket. Repeat for the other spring.

Installing

Install Springs (X500 Select Series)



CAUTION: Avoid Injury!
SPRINGS ARE UNDER TENSION.

Hold firmly during removal and installation.
Wear eye protection.

NOTE: The thatcher must be in the transport position to install springs.

Step 11-A.

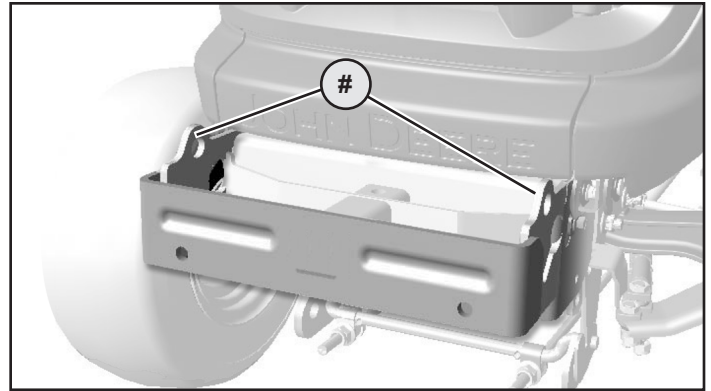

Hook the end without the finger pull loop to the weight bracket (#) on the tractor.

Step 11-B.

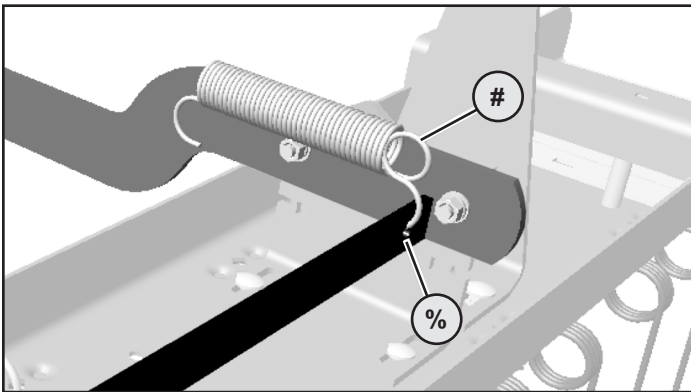

Pull the spring (Y) using the finger pull loop (#) to the cross bracket (%) on the attachment assembly.

Removing

Steps 1-2.



CAUTION: Avoid Injury! TOUCHING HOT SURFACES CAN BURN SKIN.

The engine, components, and fluids will be hot if the engine has been running. Keep hands and body away from hot surfaces when servicing or working near the engine and components.

1. Park machine safely.
(See *Parking Safely in the SAFETY section.*)
2. Raise thatcher to transport position.

Steps 3-4.

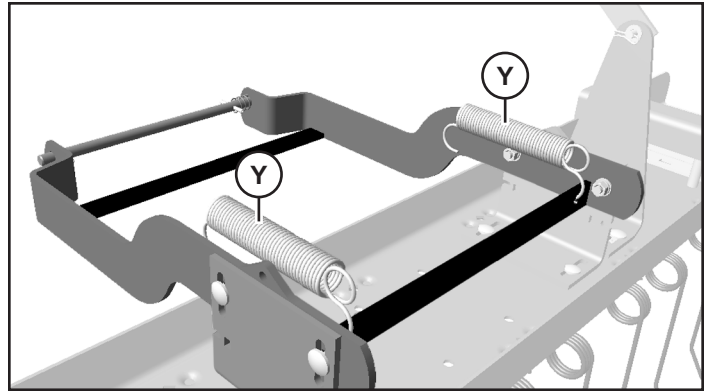

3. Unhook lift spring (Y) from thatcher, then from tractor frame. Repeat at opposite side.
4. Lower thatcher to ground.

Step 5.

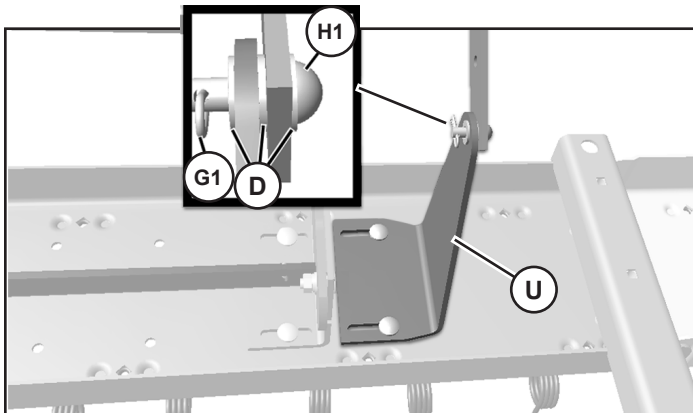

5. Remove clip pin (G1), drilled pin (H1), and three washers (D). Attach these parts to lift bracket (U) for storage.

Step 6.

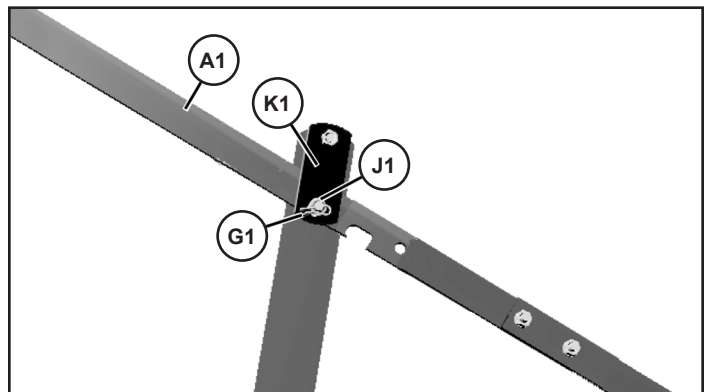

6. Remove lift handle (A1) by removing quick pull pin (G1), and drilled pin (J1). Slide lift handle down through lock bracket (K1) on lift lock extension. Install hardware back in place for storage.

Removing & Storing

Step 7. Removing, *continued.*

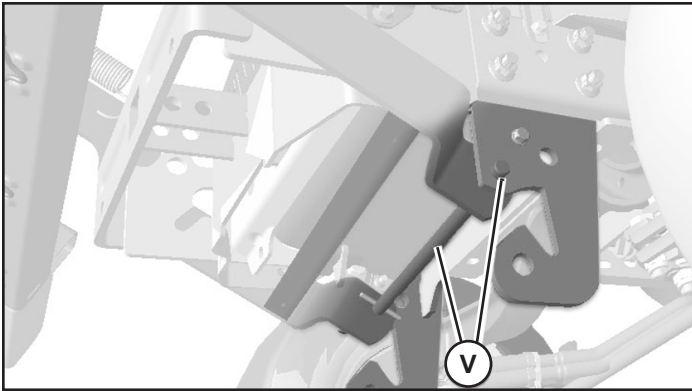

7. Push rod (V) to one side and remove from tractor frame and attaching thatcher brackets.

Steps 2-9.

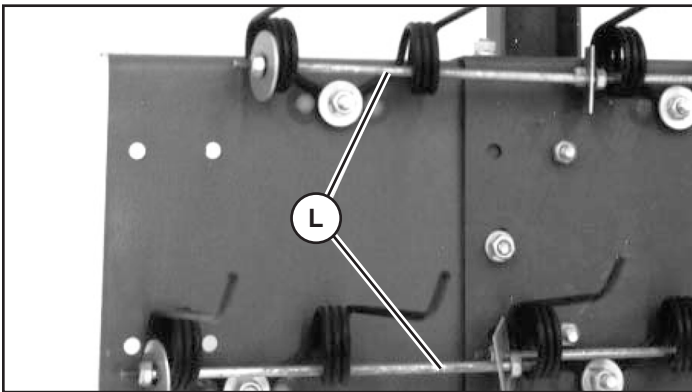

2. Secure all retention safety rods (L).
3. Clean attachment.
4. Repair or replace worn, bent, or damaged parts. Tighten loose hardware.
5. Lightly sand any rust spots on main frame and brackets and apply paint as needed.

Step 1. Storing

CAUTION: Avoid injury!



Thatcher tines can cause severe puncture wounds and death! Prevent contact with thatcher tines:

- *Always store thatcher with tines facing floor surface.*
- *Never store thatcher on elevated shelving. Thatcher could fall onto bystanders.*

Before placing thatcher in storage:

1. Tighten loose tines.
Replace damaged or missing tines.

6. Apply paint to painted surfaces where needed to prevent rust.
7. Apply a thin coat of grease to tines to prevent rust.
8. Lubricate any pivot points with engine oil to prevent rust.



CAUTION: Avoid damage!
ABRASIVE SURFACES CAN DAMAGE THE ATTACHMENT.

Store attachment on non-abrasive surface or on wooden blocks.

9. If storing attachment outdoors, block up attachment if possible and place a waterproof cover over it.

Operation

What is Thatch?

- Thatch is a layer of stems, clippings and leaves that has not decayed.
- Thatch builds up between the ground surface and the green part of grass.

Excessive thatch (12.7 mm (1/2 in.) or more), prevents proper amounts of air, water and fertilizer from reaching grass roots. Excessive thatch may also kill grass, providing a favorable environment for insects and encourages plant disease.

Main Cause of Thatch

A small amount of thatch is beneficial to lawns because it protects roots from direct sunlight, yet allows air, water and fertilizer to reach roots.

Decaying thatch also acts as fertilizer to promote grass growth. However, decay of grass clippings is a slow process. Thatch build-up can occur by over-fertilization, resulting in fast plant growth and more frequent mowing.

NOTE: Not all grass clippings are picked up when mower bagging attachment or lawn sweeper is used.

With a slow decaying process, a layer of thatch can build up enough to smother the grass root system.

When to Use Thatcher

Every lawn is different, so there is no rule for when to use the thatcher (which actually de-thatches, or loosens thatch so it can be removed from lawn). In general, the thatcher should be used more often on very dense lawns.

- Consult your local agriculture extension service to determine when and how often to de-thatch lawn.
- Ground conditions should be dry to help prevent damage to grass root system.
- Summer de-thatching is not recommended.

Using Thatcher to Seed

Thatcher can be used as a scarifier to scratch new ground to seed, or an established lawn to reseed. Lower tines 6.4 mm (1/4 in.) at a time until, when operating, tines stay in their rearward working position, scratching ground and producing a good seedbed for seeds to germinate.

Do Not Modify Thatcher

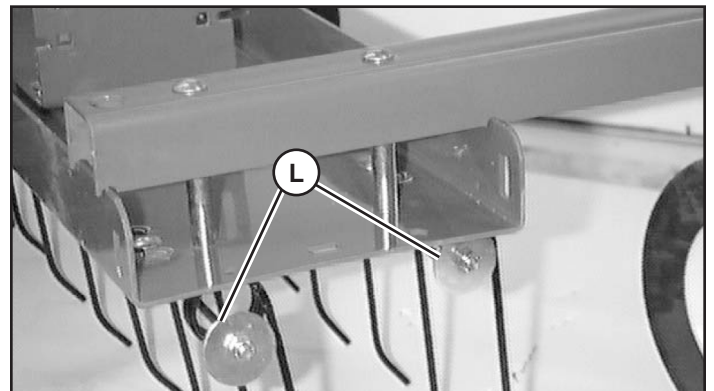

Unauthorized modifications of thatcher may impair its function or safety, and reduce thatcher longevity.

Retention safety rods (L) prevent loose or broken tines from falling into mower path. Do not alter or remove any part of tine retention safety rods. If retention safety rods break or become removed from thatcher, replace rods with parts from dealer before continuing thatcher operation.

Operation

Using Lift Handle

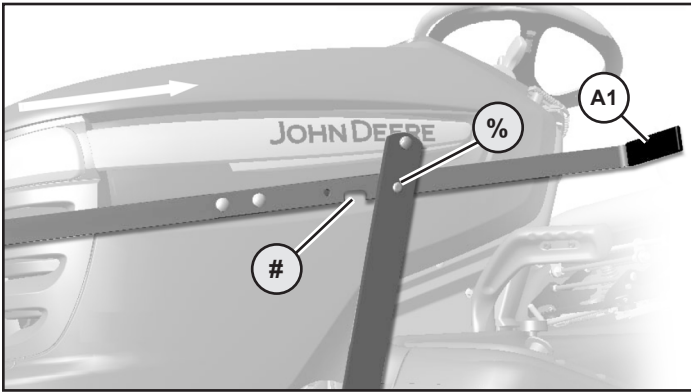

To Raise Thatcher: Pull lift handle (A1) toward rear of machine until notch (#) locks on drilled pin (%).

To Lower Thatcher: Grasp lift handle (A1) firmly and raise upward until notch (#) unlocks from drilled pin (%). Next, slowly lower thatcher to ground.

Adjusting Gauge Wheels

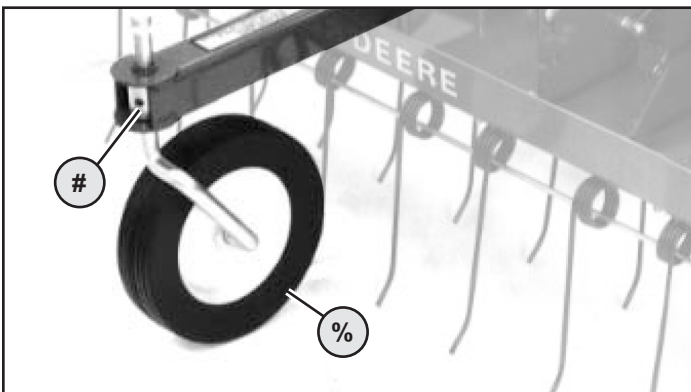

The height of gauge wheels determines operating depth of thatcher.

1. Loosen set screw (#) with hex wrench to adjust gauge wheel (%) height.
2. Tighten set screw (#) at desired depth setting.

Adjusting Tine Action

Grass should be less than 76.2 mm (3 in.) tall for proper tine action. When in use, all tines on thatcher should deflect back independently and flip thatch forward.

In the Free Position (1), tines are relaxed and not working.

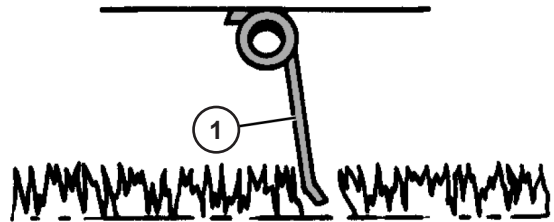

In the Thatching Position (2), the tines are rearward and working.

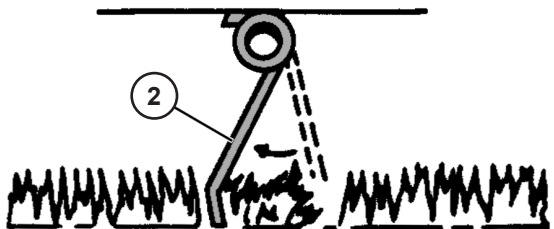

Released Position (3), tines are flipping thatch up, ready to be picked up by mower / bagger or sweeper.

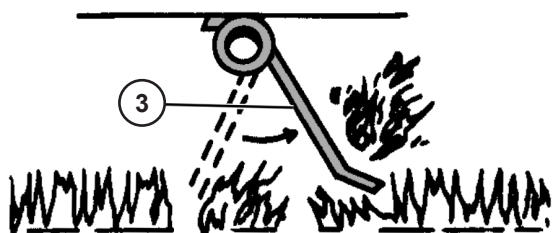

Operation

Thatching

Set thatcher tines in released position (3) to loosen thatch for removal from lawn.

- If tines remain in thatching position (2) where they work but do not flip thatch up, raise main frame.
- If tines remain in free position (1) where they do not work or lift thatch, lower main frame.

Seeding

Set thatcher tines to remain in thatching position (2) to seed or reseed lawn.

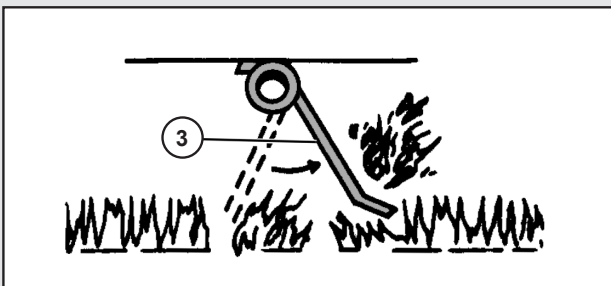
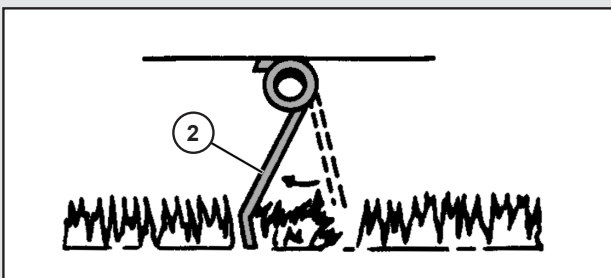
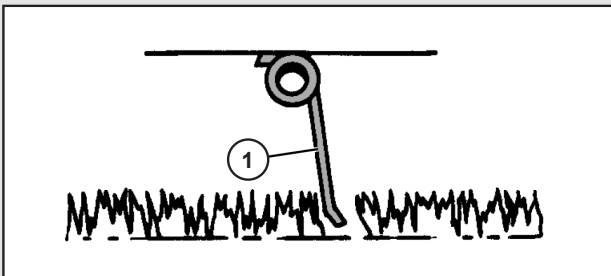

Leveling Thatcher Steps 1 & 2.



NOTE: Level thatcher only when installed on tractor.

1. Park machine safely.
(See *Parking Safely in the SAFETY section.*)
2. Lower thatcher slowly to ground by lifting and slowly releasing lift handle (A1).

Step 3.

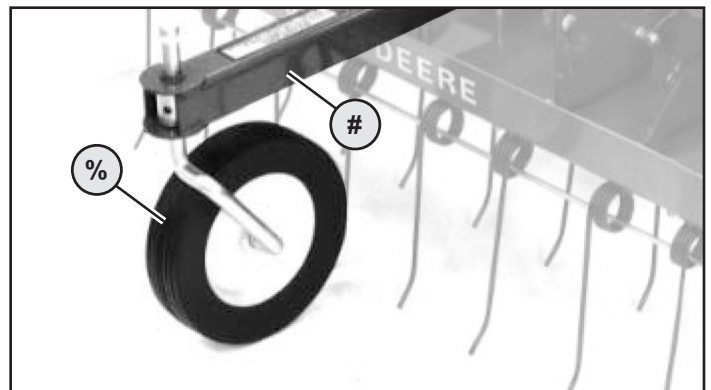

3. Align each gauge wheel (%) directly under wheel support (#).

Operation

Step 4.

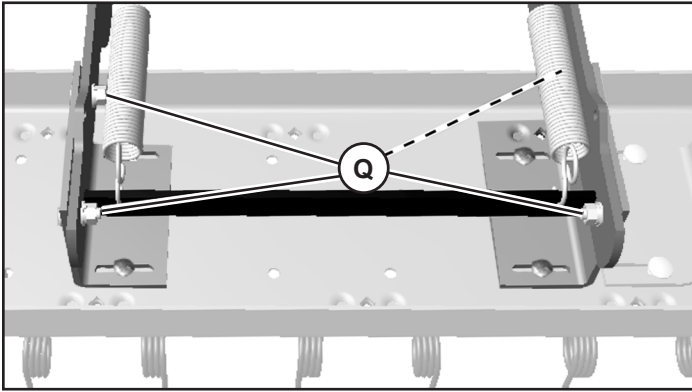

4. Loosen mounting frame nuts (**Q**) securing thatcher to mounting frame.

Step 5.

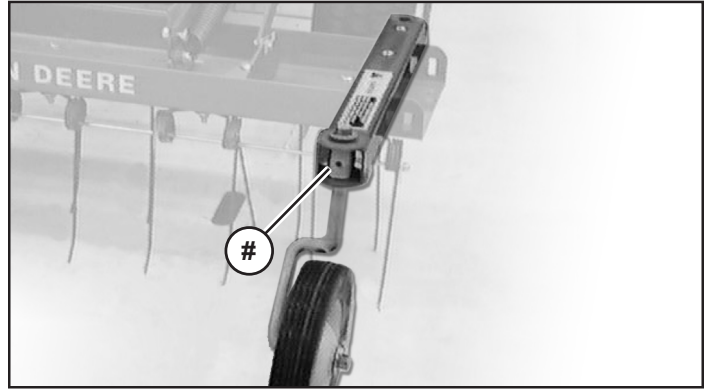

5. Loosen set screw (**#**) on each gauge wheel.

Steps 6-8.

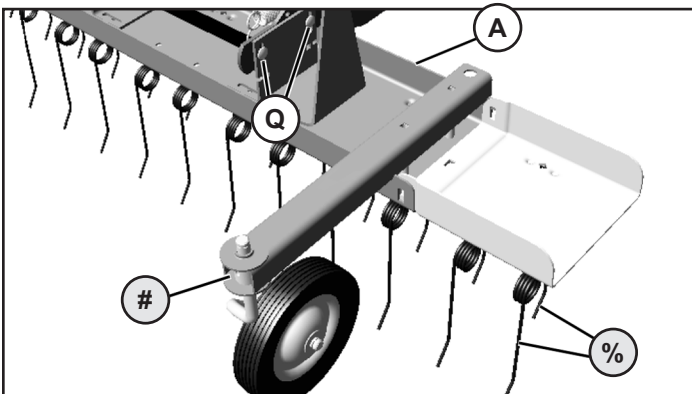

6. Adjust height of thatcher frame (**A**) so both tine rows (**%**) are approximately 12.7 mm (1/2 in.) above the ground in the free position. Tines should touch flat surface when manually deflected rearward.
7. Tighten mounting frame nuts (**Q**) and gauge wheel set screws (**#**).
8. Operate thatcher in lawn after initial leveling and centering adjustments. Make further leveling adjustments only 6.4mm (1/4in.) at a time.

REMINDER: Adjust tines to released position to loosen and flip up thatch for removal by mower / bagger.

Operation

Centering Thatcher

Steps 1-7.



NOTE: Center thatcher only when installed on tractor.

1. Park tractor on level surface, not on slope.
2. Disengage power take-off (PTO).
3. Lock park brake.
4. Turn off ignition key.
5. Wait for engine and all moving parts to stop.
6. Remove ignition key.
7. Lower thatcher slowly to ground by releasing lift handle.

Step 8.

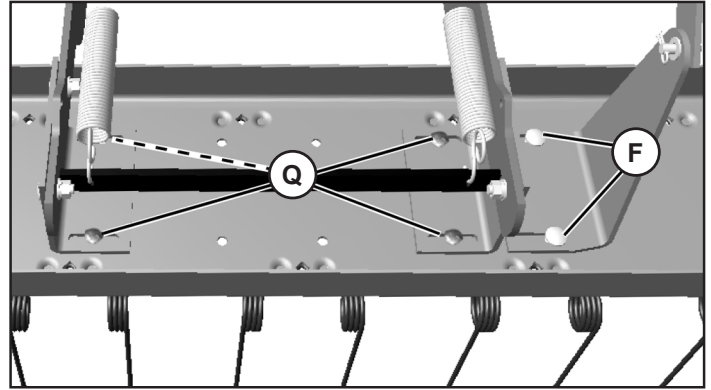

8. Loosen carriage bolts (**F**) and (**Q**) so lift handle bracket and frame mounting brackets can slide in adjustment slots.

Steps 9-10.

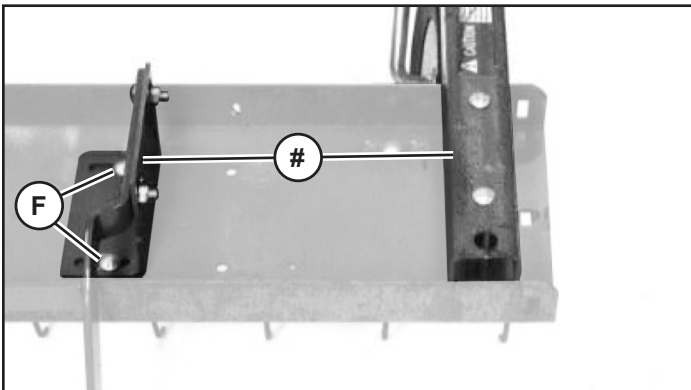

9. Adjust thatcher by sliding frame mounting brackets left or right in adjustment slots. Keep distance (**#**) between gauge wheel support and mounting bracket equal on both sides of thatcher.
10. Tighten carriage bolts (**F**) on frame mounting brackets.

Step 11.

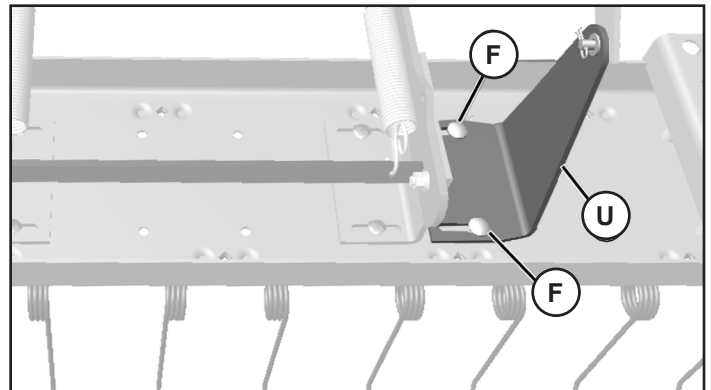

11. Align lift handle bracket (**U**) so lift handle remains straight as it leaves lift lock extension mounted at tractor frame. Tighten carriage bolts (**F**).

Operation

Checking Thatcher Tines

NOTE: Do not overlook this step. Broken tines can be picked up and thrown by mower.



CAUTION: Avoid injury! A mower can pick up and throw broken tines.

Check tines on entire unit before and during each use. Replace cracked or broken tines before using thatcher.

Check all retention safety rods. Secure if loose. Replace if damaged. Do not alter or remove.

1. Check tines (**K**) on entire unit for breaks or cracks. Replace broken or cracked tines with parts from the dealer.

2. Make sure retention safety rods (**L**) pass through all tines and are secured at ends with washer and locknut.

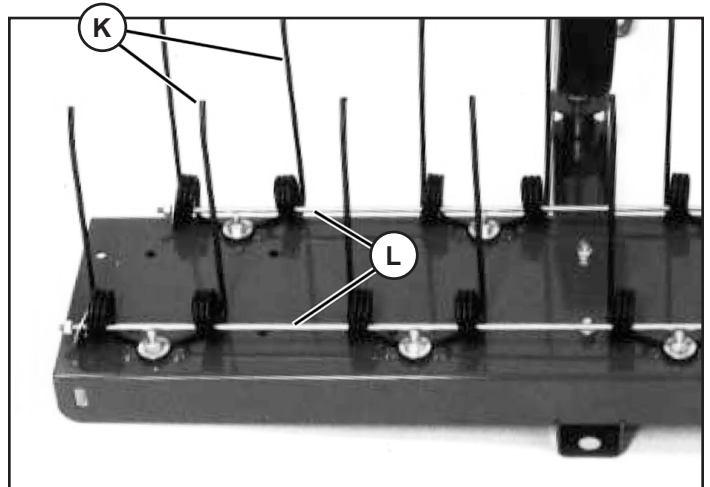

Transporting Thatcher

NOTE: When transporting, lock the thatcher in transport position.



CAUTION: Avoid injury! Stop the machine before attempting to raise thatcher to transport position.

Reduce speed when transporting thatcher in rough terrain. Always transport unit in up (transport) position.

1. Pull lift handle (**A1**) toward rear of tractor.

2. Remove the spring locking pin (**J1**) and drilled pin (**G1**).

3. Align the hole (**#**) from lift handle and lift lock extension and install drilled pin.

4. Secure with spring locking pin.

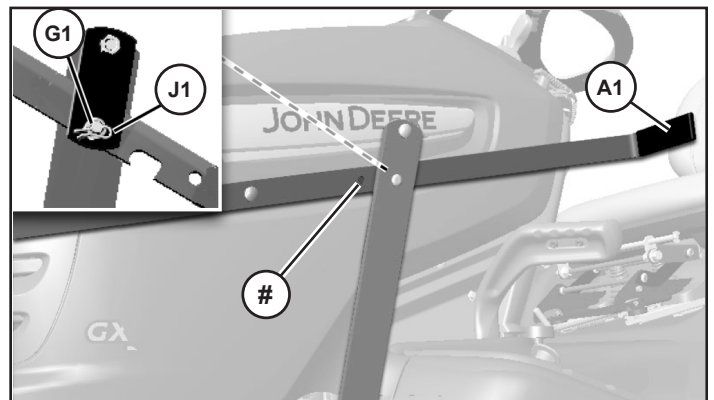

Service

Replacing Tines



CAUTION: Avoid injury!
Tines are sharp.

- *Wear heavy gloves when working around tines.*
- *Do not work under raised attachment unless it is safely supported.*

Steps 1 & 2.

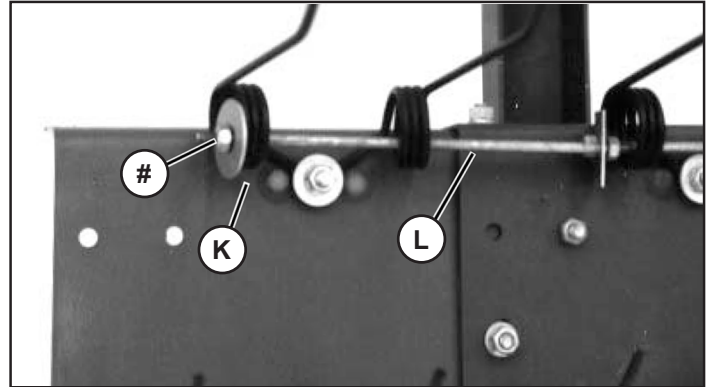

1. Remove locknut and washer (#) from end of retention safety rod (L). Keep nut and washer.
2. Slide rod (L) from damaged tine set (K).

Step 3.

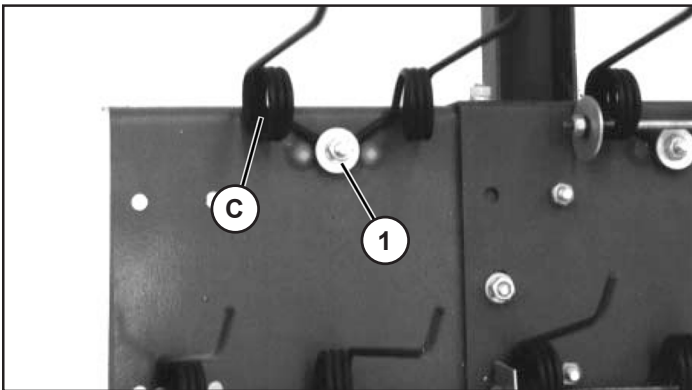

3. Remove hex nut, carriage bolt, lockwasher, and flat washer (1). Remove and discard damaged tine set (K).

Steps 4 & 5.

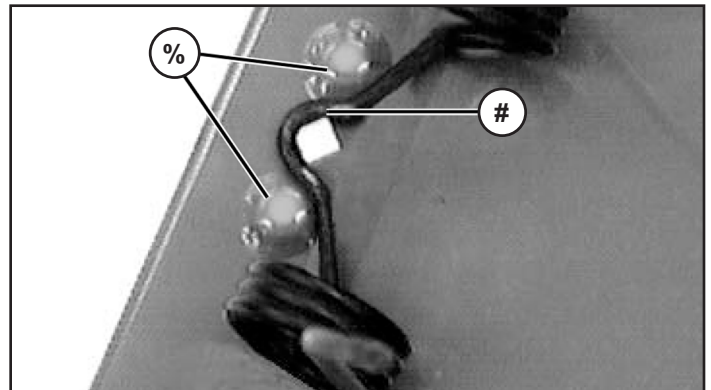

NOTE: Offset (#) in tine wire should be between two frame extrusions (%) for proper assembly.

4. Attach new tine set, making certain tine tips face same direction as other tines on thatcher. Secure new tine set with original carriage bolt, flat washer, lockwasher, and hex nut. Tighten completely.
5. Insert retention safety rod through all tines sets. Secure with original washer and locknut. Tighten completely.

Troubleshooting / Quality

Using Troubleshooting Chart

If you are experiencing a problem that is not listed in this chart, see your authorized dealer for service.

When you have checked all the possible causes listed and you are still experiencing the problem, see your authorized dealer.

If	Check
Debris Gets Stuck in Thatcher	Back machine up with thatcher lowered to free debris.
Thatcher is Uneven	Level thatcher.
Strips of the Lawn Not Thatched	Center thatcher.

Notes:

This product was manufactured by Brinly-Hardy Co., a John Deere Licensee, located at 3230 Industrial Pkwy, Jeffersonville, IN 47130. If you have any questions or concerns with the assembly, installation or operation of this attachment see your local John Deere Dealer or call Brinly-Hardy Co. at 866-218-8622 for assistance.

John Deere Quality Continues with Quality Service

John Deere provides a process to handle your questions or problems, should they arise, to ensure that product quality continues with quality parts and service support.

Follow the steps below to get answers to any questions you may have about your product.

1. Refer to your attachment and machine operator manuals.
2. In North America or Canada, call Brinly-Hardy Co. Customer Service at 1-866-218-8622 and provide product serial number (if available) and model number.

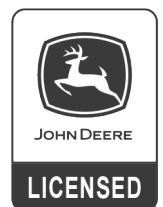

Warranty

Limited Warranty for New John Deere Licensed Products

A. General Provisions – The warranties described below are provided by manufacturer, Brinly Hardy Company, on John Deere Licensed products to the original purchaser of new Lawn and Garden attachments from authorized John Deere Dealers & Retailers. Under these warranties, the manufacturer will repair or replace, at its option, any covered part found to be defective in material or workmanship during the applicable warranty term. The purchaser will be responsible, however, for any service call and / or transportation of product to and from the dealer's place of business, for any premium charged for overtime labor requested by the purchaser, and for any service and/or maintenance not directly related to any defect covered under the warranties below.

B. What is warranted – All parts of any new John Deere Licensed product, are warranted for the number of months specified below. When you call please have the serial number, if applicable, and model number.

C. What is not warranted – 1) Used products; (2) Any product that has been altered or modified in ways not approved by the manufacturer; (3) Depreciation or damage caused by normal wear, lack of reasonable and proper maintenance, failure to follow operating instructions, misuse, lack of proper protection during storage, or accident; (4) normal maintenance parts and service.

D. Securing Warranty Service – To secure warranty service, the purchaser must (1) report the product defect to an authorized dealer, or to the manufacturer by calling 866-218-8622, and request repair within the applicable

warranty term, (2) present evidence of the warranty start date, and (3) make the product available to the dealer or service center within a reasonable period of time.

E. Limitation of implied warranties and other remedies – To the extent permitted by law, neither John Deere nor any company affiliated with it makes any warranties, representations or promises as to the quality, performance or freedom from defect of the equipment covered by this warranty. Implied warranties of merchantability and fitness for a particular purpose, to the extent applicable, shall be limited in duration to the applicable period of warranty set forth on this page. The purchaser's only remedies in connection with the breach or performance of any warranty on the John Deere Lawn and Garden attachments are those set forth on this page. In no event will the Dealer, John Deere or the manufacturer be liable for incidental or consequential damages. (Note: Some states do not allow limitations on how long an implied warranty lasts or the exclusion or limitation of incidental or consequential damages so the above limitations and exclusions may not apply to you.) This warranty gives you specific legal right, and you may also have other rights, which vary from state to state.

F. No Dealer Warranty – The selling Dealer makes no warranty of its own and the Dealer has no authority to make any representation or promise on the behalf of John Deere or the manufacturer to modify the terms or limitations of the warranty in any way.

Manufacturer's Lawn & Garden Attachments	*Warranty Term
Steel Frame	2 Years
Transmission (gearbox)	2 Years
Poly Hoppers & Beds	2 Years
Wheels	1 Year
Hydraulics	1 Year
Drive Gears	1 Year
Other normal wear parts	1 Year

**Each Warranty Term begins on the date of product delivery to the purchaser.*

Register your John Deere Licensed Product by completing & mailing in the enclosed Warranty Registration Card.
For Customer Service: Please call 866-218-8622