

ROHL

Authentic Luxury for Kitchen and Bath®

www.rohlhome.com



RETRO-FIT SHOWER COLUMN RISER WITH DIVERTER/HANDSHOWER/ HOSE/SHOWERHEAD SET

ROHL Spa Shower

L0095KIT2

FEATURES

- Complete with the following items:
 - L0095: Retro-fit shower column riser with diverter
 - B0311: Cylindrica single-function handshower
 - WI0195: Dinamic 3-function showerhead
 - A40/1: Flexible 59" metal hose
- Flow rate 2.0 GPM
- Tuscan Brass and Inca Brass not available

COLORS/FINISHES

- Polished Chrome
- Polished Nickel
- Satin Nickel

WARRANTY

- Limited Lifetime

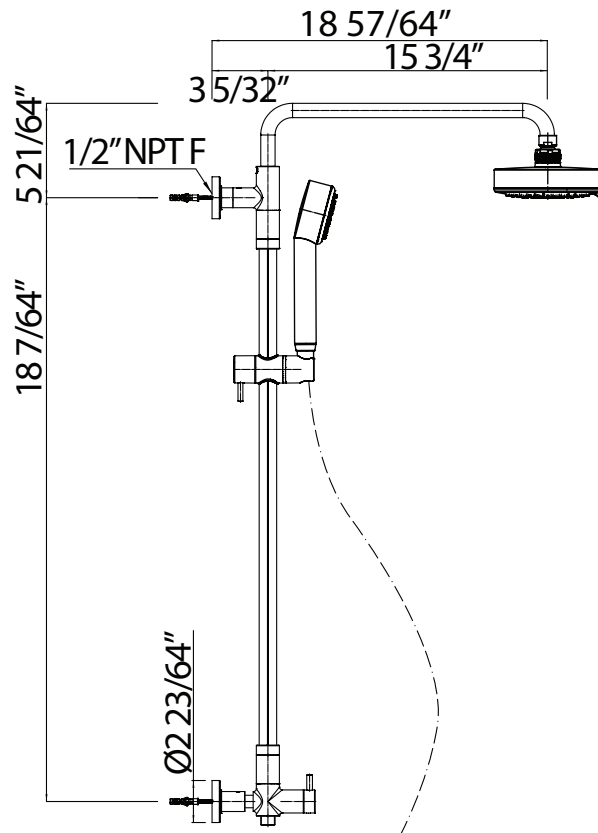

Consult your local ROHL showroom for additional information and specifications. For complete warranty details and a list of showrooms, go to www.rohlhome.com.



INSTALLATION INSTRUCTIONS

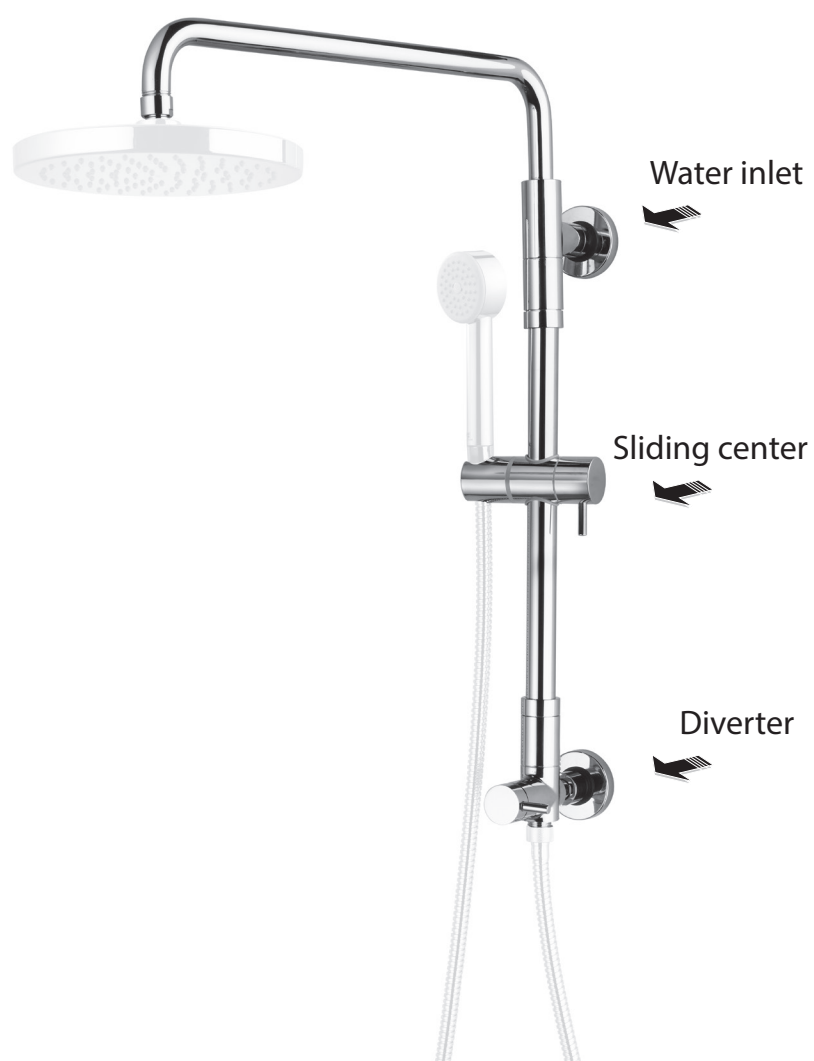

INSTALLATION INSTRUCTIONS

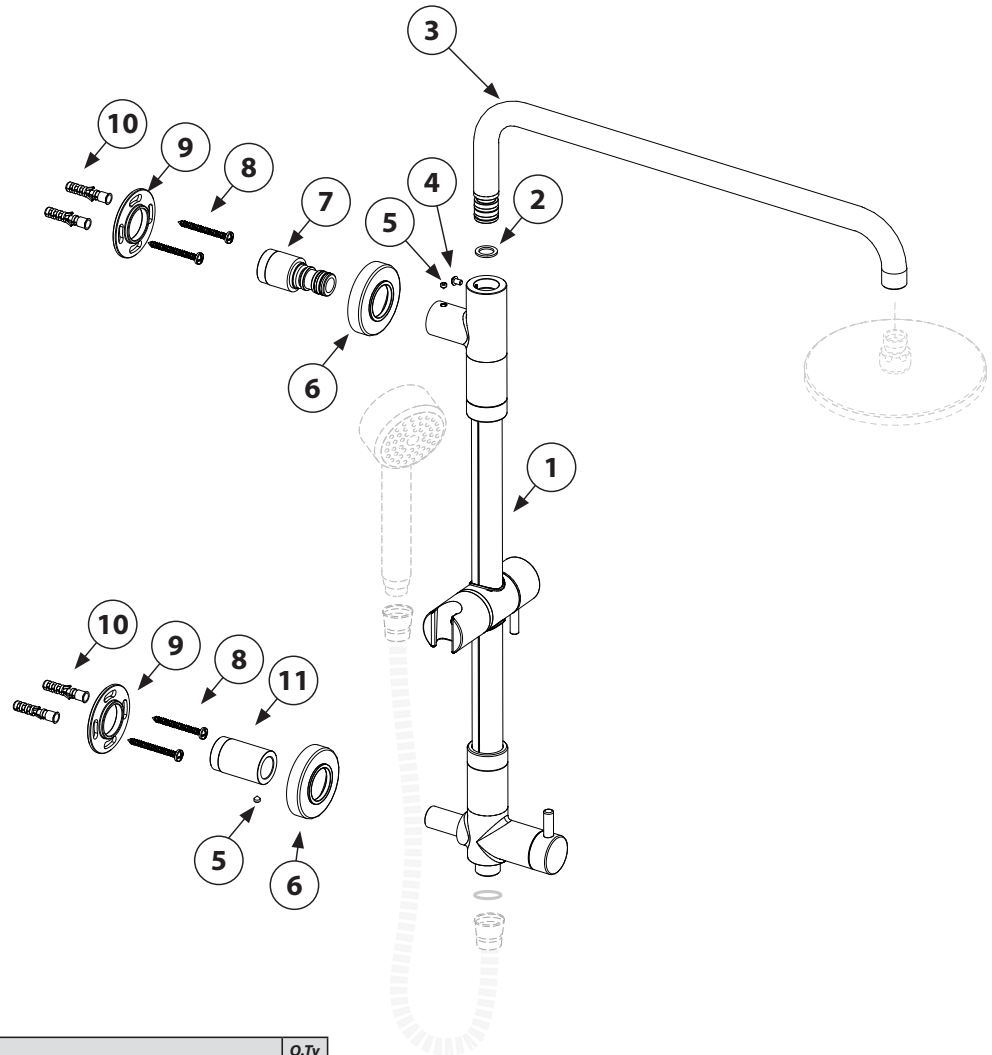

Package content

Item	Description	Q.Ty
1	Straight pipe assembly	1
2	Friction ring	1
3	Arm	1
4	Screw	1
5	Grub screws	2
6	Flange cover	2
7	Female NPT inlet nipple	1
8	Mounting Screws Ø5 x 50 mm	4
9	Mounting Ring	2
10	Wall Anchors	4
11	Lower support	1



READ THIS INSTALLATION AND CARE MANUAL CAREFULLY.



WEAR PROTECTIVE GLOVES.

INSTALLATION INSTRUCTIONS

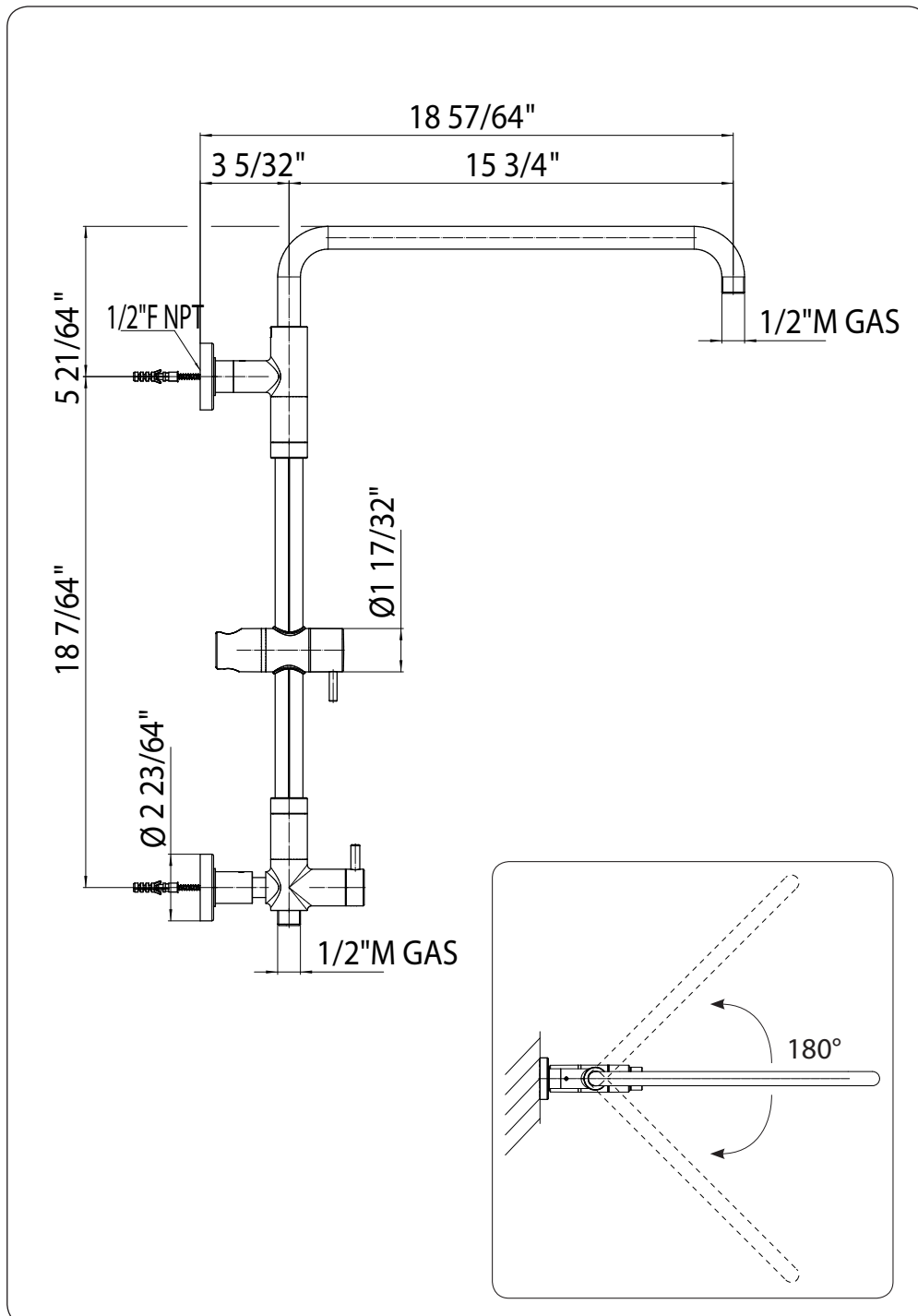

INSTALLATION INSTRUCTIONS

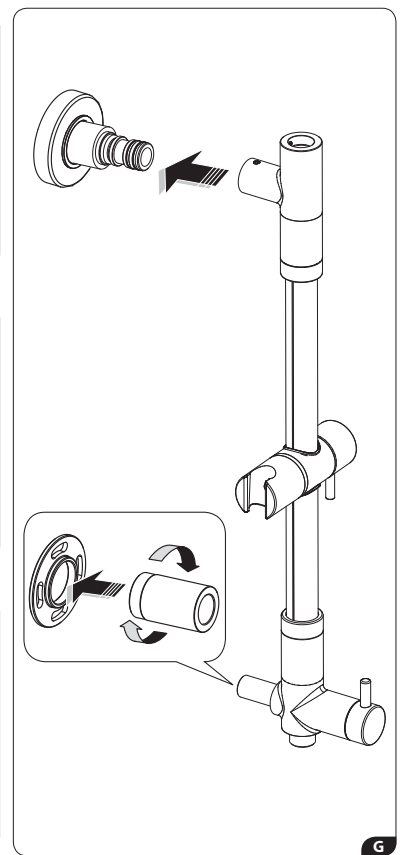
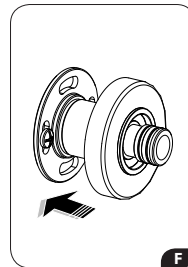
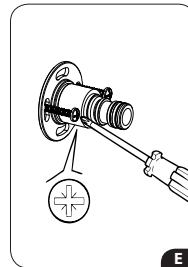
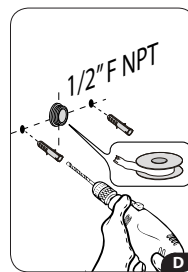
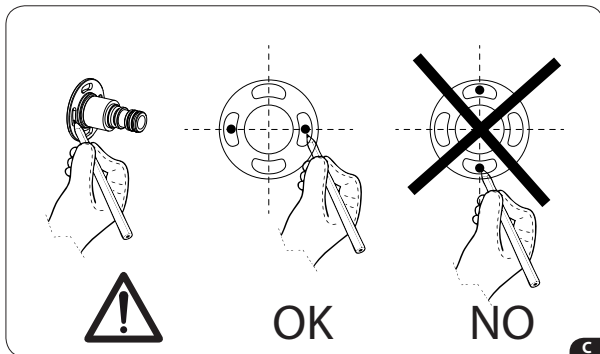
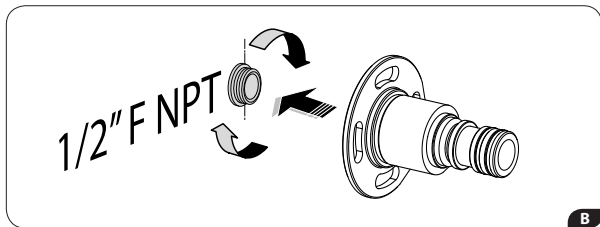
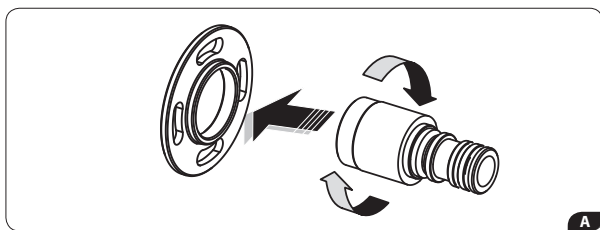

ROHL

Authentic Luxury for Kitchen and Bath®

www.rohlhome.com

INSTALLATION INSTRUCTIONS

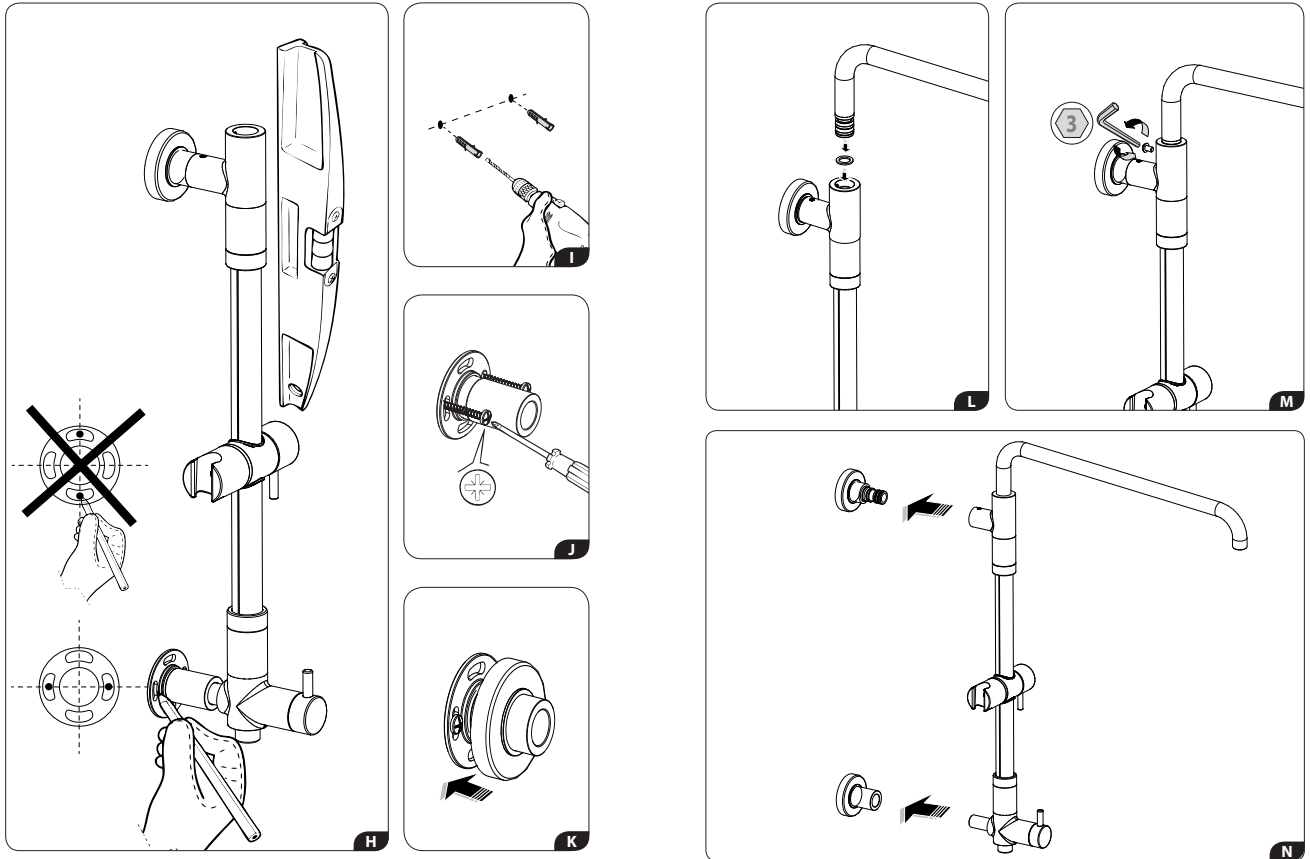

INSTALLATION INSTRUCTIONS

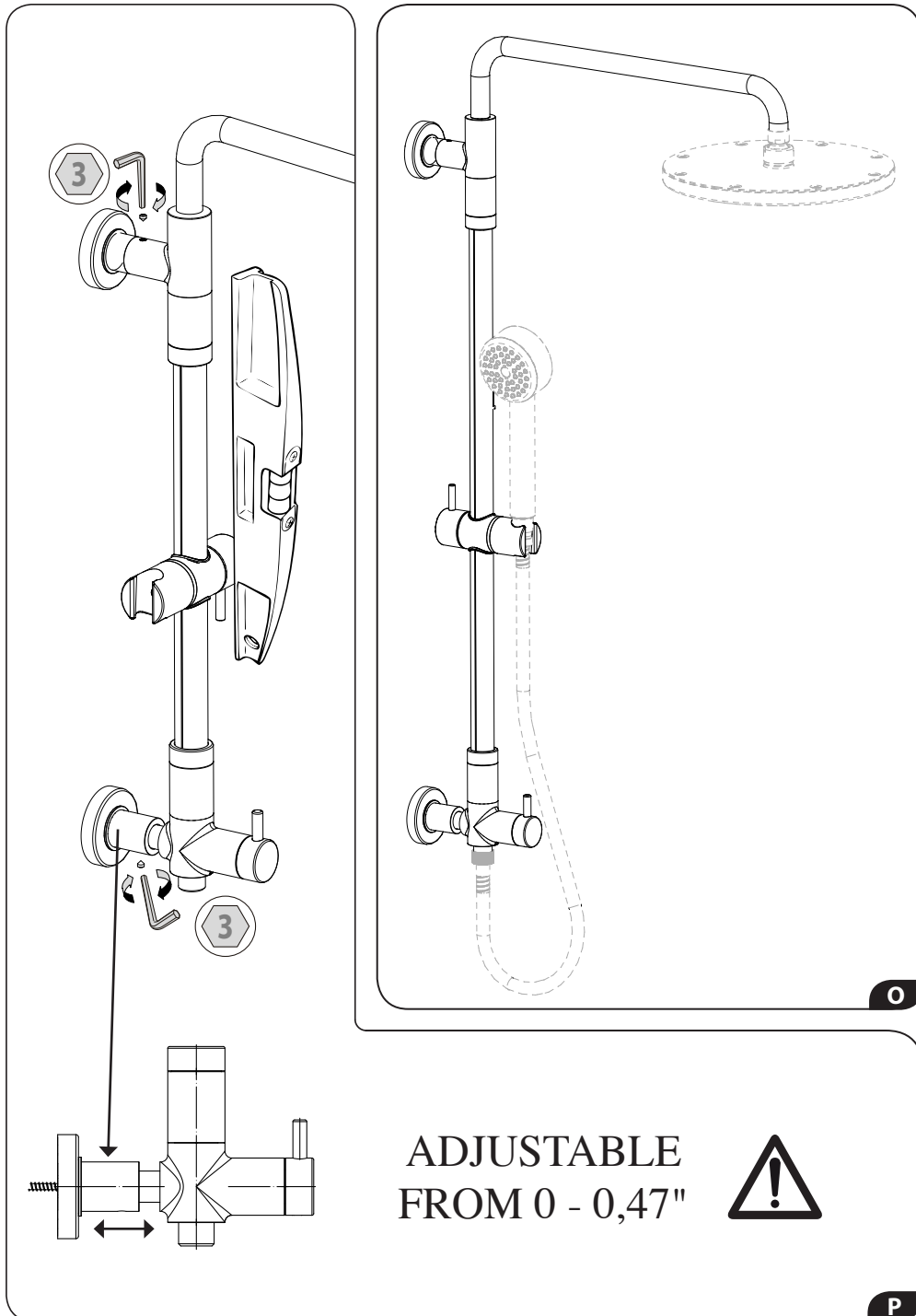

INSTALLATION INSTRUCTIONS

Recommendations For Proper Use

Proper use of this product will avoid damages to the bathroom environment.

** To prevent impurities or debris from getting inside the product and causing functional problems, flush out the system before connecting it to the supply pipes. **It is recommended to install the filter at the system's water intake.***

** To keep the diffuser clean and prevent lime scales from clogging the diffuser, we advise that you periodically rub the silicone nozzles to free them of the lime deposits.*

Cleaning

Congratulations for choosing a ROHL product and we thank you for the trust you have given us. To keep the material's appearance as long as possible, a few guidelines must be followed.

Cleaning metal parts: water contains calcium that forms unpleasant spots. For routine cleaning, simply use a damp cloth with a little soap, rinse and dry. Calcium spots can be avoided by drying after use.

Important note: Using only a soap-based detergent is recommended. Never use abrasive detergents or disinfectants or those containing alcohol, hydrochloric acid or phosphoric acid, Bleach, chlorine etc

Cleaning the rubber nozzles: the showerhead is equipped with the "Easy-Clean" system with silicon nozzles. Calcium is a shower's worst enemy and that is why ROHL proposes the "Easy-Clean" system. These silicon nozzles are extremely heat resistant and with hot water they dilate, thus detaching the first layer of calcium. Periodically rubbing the silicon nozzles manually easily gets rid of calcium. With one simple gesture, your shower is always perfect.

We would like to remind you that the warranty on our product's surface is not valid if the material undergoes treatment different than that suggested. The warranty does not cover any damage due to deposits of calcium or impurities.

INSTALLATION INSTRUCTIONS

Warranty Terms

Dear Customer,

We congratulate you and thank you for choosing a ROHL quality product. The product is covered by 2 Years warranty against any defects due to manufacturing faults.

The warranty does not cover damages caused by improper installation or use, neglect, incorrect plumbing, normal fair wear and tear, damages caused by limescale deposits or impurities, the use of detergents and maintenance products other than those specifically recommended in our instructions manual. Furthermore ROHL is not responsible for labor costs and/or damages, whether accidental or consequent to the installation, repairing or replacement of the product. The request for replacement under the terms of this warranty must be made in a letter setting out the date and place of purchase and giving a brief explanation of the problem. The letter must be received by us within the warranty period and must be accompanied by proof of the purchase date (e.g. a receipt). The warranty only covers production faults / defects and is strictly limited to the repair or free replacement of the parts which are recognised to be defective. The defective parts have to be returned to ROHL carriage free with a report describing the defect. ROHL reserves the right to inspect the part alleged to be faulty or defective and to evaluate the applicability of the warranty terms.

The warranty period commences on the date the product is purchased, evidenced by the relevant purchase document (e.g. receipt, invoice, cash voucher) and it is NOT renewable.

For further information please contact ROHL or its distributor.