



IMPORTANT

Carefully remove all the parts from the carton and place them individually on a soft cloth to prevent scratches or other damage.

Carefully and strictly follow these assembly instructions to ensure a completed product as designed.

Do not use power tools above 8 volts to assemble.

Part List

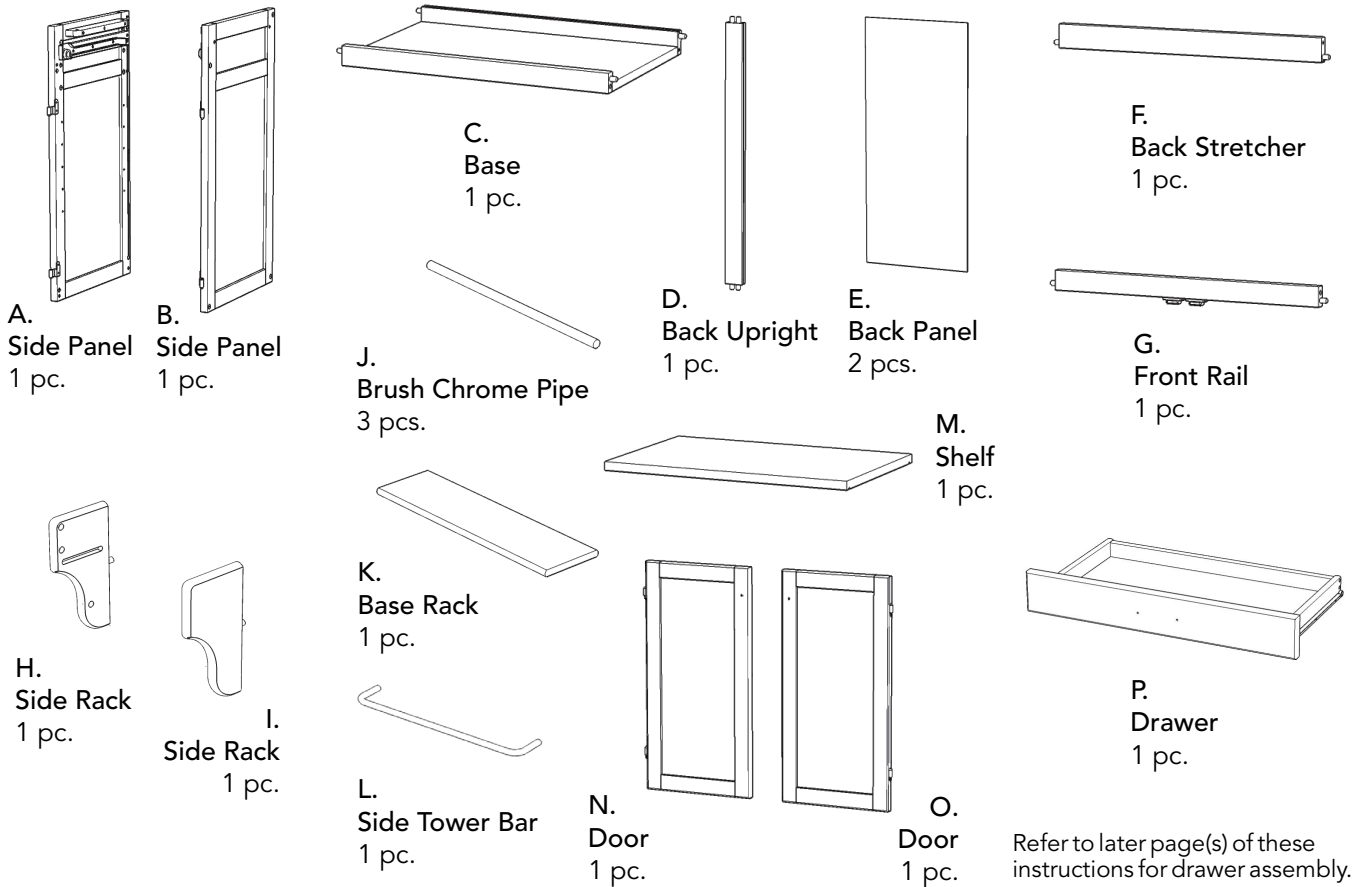

Hardware List

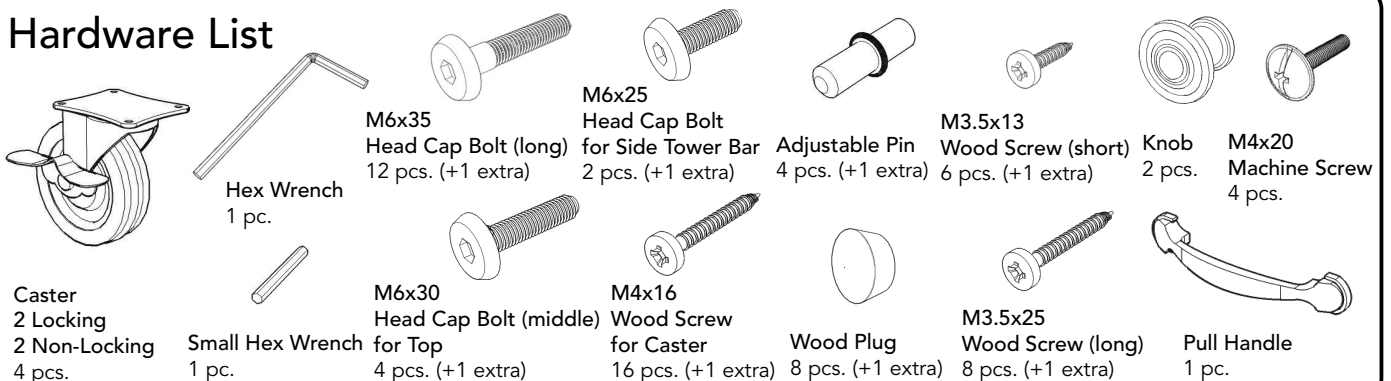

Tool(s) required for assembly: Phillips screwdriver

Assembly Instructions 2/5

IMPORTANT

- Use a soft cloth between these parts and the floor.
- Do not use power tools above 8 volts to assemble.
- Do not tighten all the bolts until each part is properly assembled.
- Keep Hex Wrench in a safe place as the bolts may need to be tightened up in the future.

STEP 1

Attach Casters underneath Base (C) with Wood Screws for Caster, with Locking Casters on the front. (See Figure 1)

Note: The 'Arrow' sticker indicates the front of Base (C).

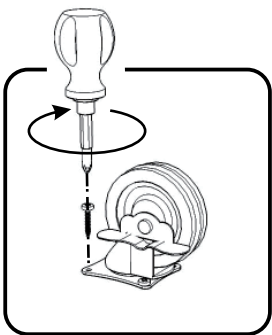
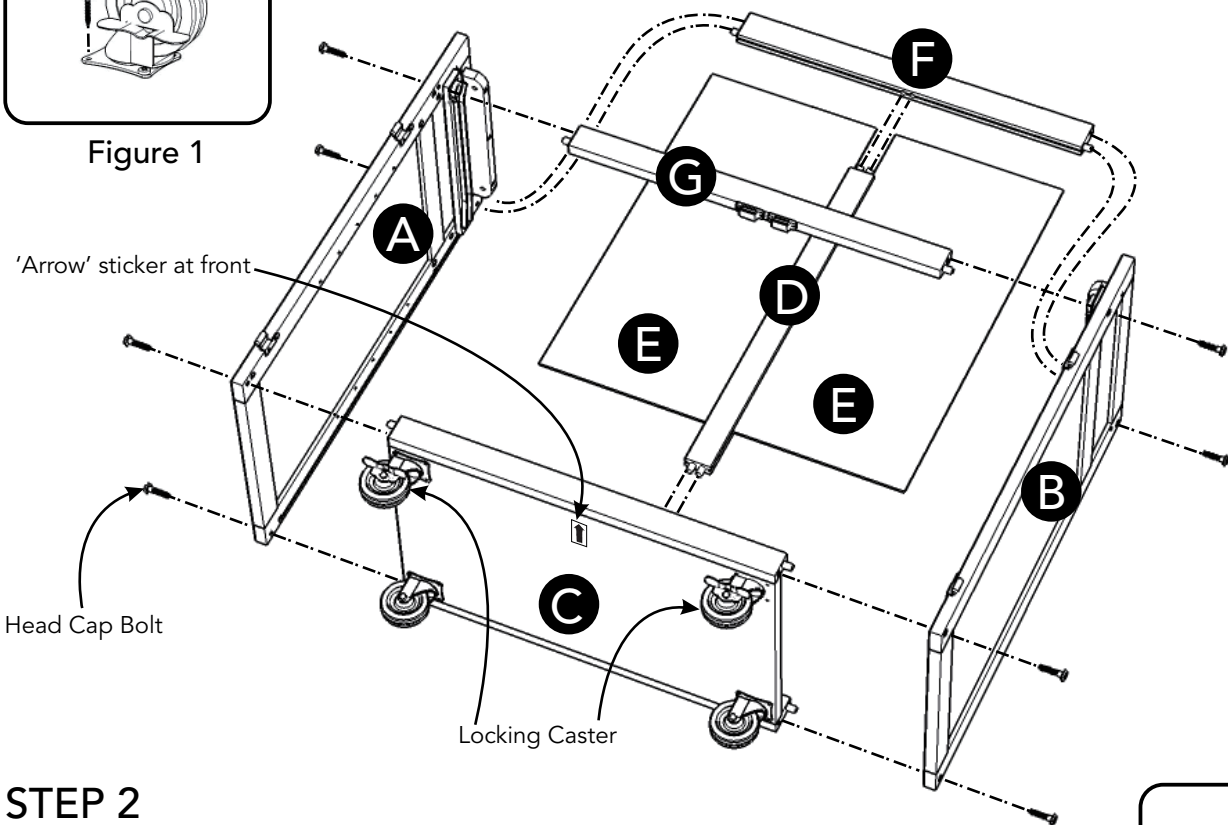
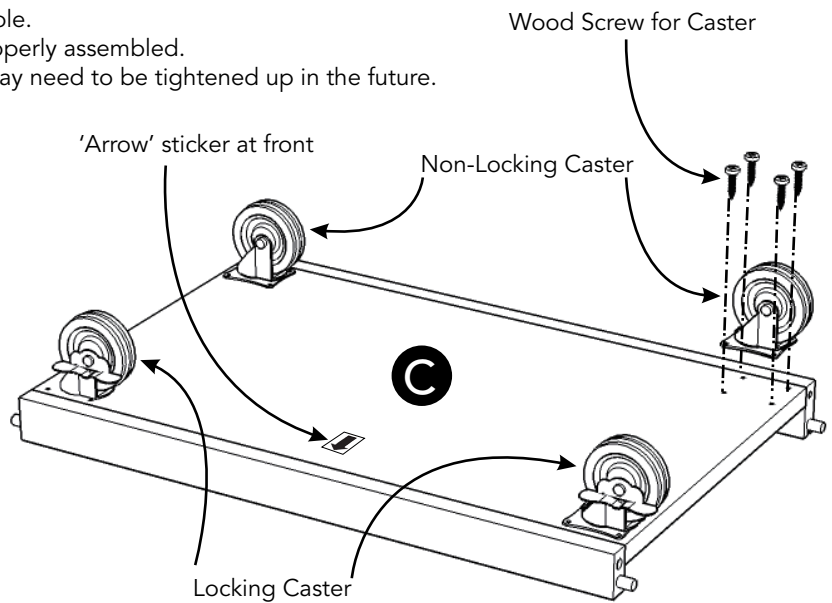

Figure 1



STEP 2

Attach Side Panel (A) to Base (C) with Head Cap Bolts. (See Figure 2)

Attach Back Upright (D) to Base (C).

Slide Back Panels (E) into place.

Attach Back Stretcher (F) and Front Rail (G) to Side Panel (A) with Head Cap Bolts.

Attach Side Panel (B) to unit with Head Cap Bolts.

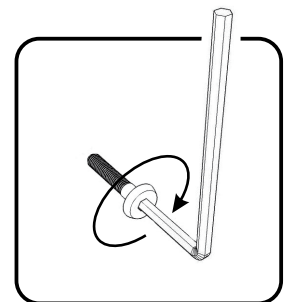

Figure 2

Assembly Instructions 3/5

STEP 3

Attach Side Rack (H) to Side Panel (A) with Head Cap Bolts.

Slide Brush Chrome Pipes (J) and Base Rack (K) into Side Rack (H).

Attach Side Rack (I) to Side Panel (A) with Head Cap Bolts.

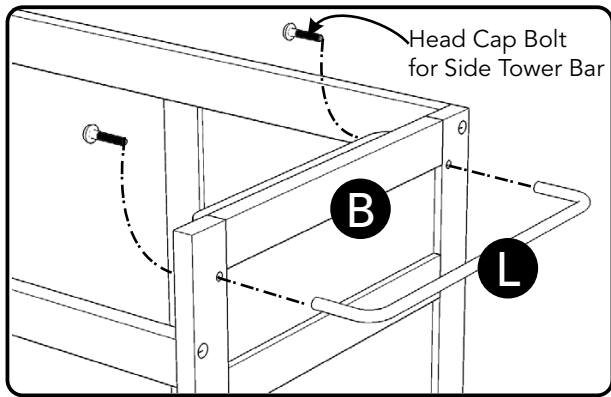
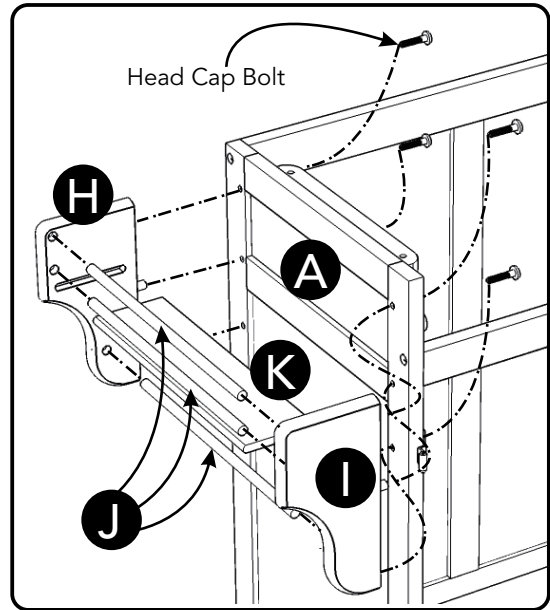

STEP 4

Attach Side Tower Bar (L) to Side Panel (B) with Head Cap Bolts for Side Tower Bar.

STEP 5

Attach Top to unit with Head Cap Bolts for Top.

Insert Adjustable Pins into side panels at the desired level. (See Figure 3)

Place Shelf (M) into position.

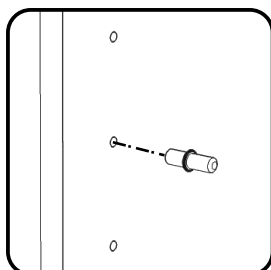
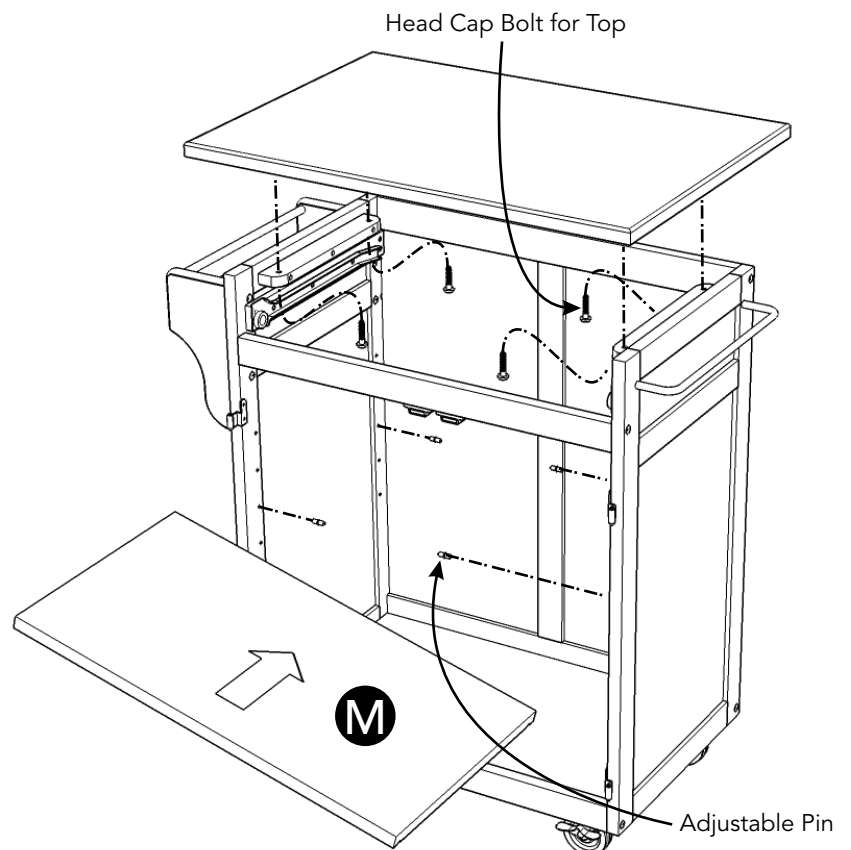
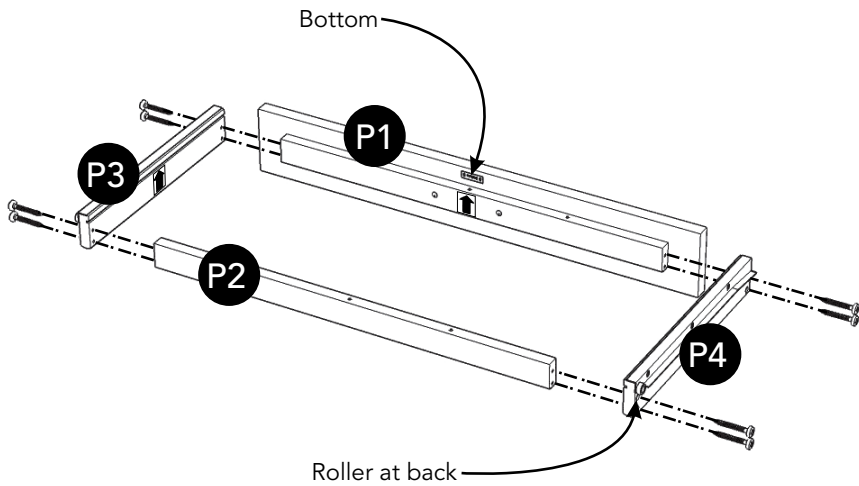
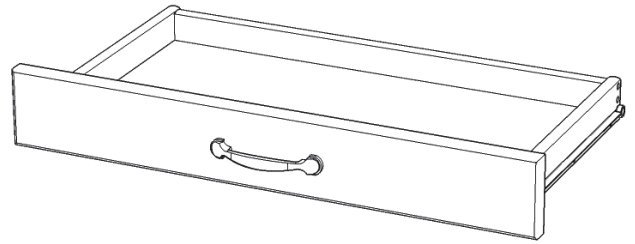

Figure 3



Assembly Instructions 4/5

Drawer (P)



STEP 6

Attach Drawer Front (P1) and Drawer Back (P2) to Drawer Side (P3) with Wood Screws (long).

Attach Drawer Side (P4) to unit with Wood Screws (long).

STEP 7

Slide Drawer Bottom (P5) into the grooves of Drawer Sides (P3) and (P4) until it meets Drawer Front (P1).

Attach Drawer Bottom (P5) to unit with Wood Screws (short).

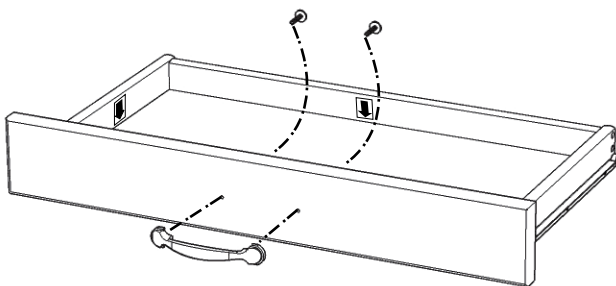
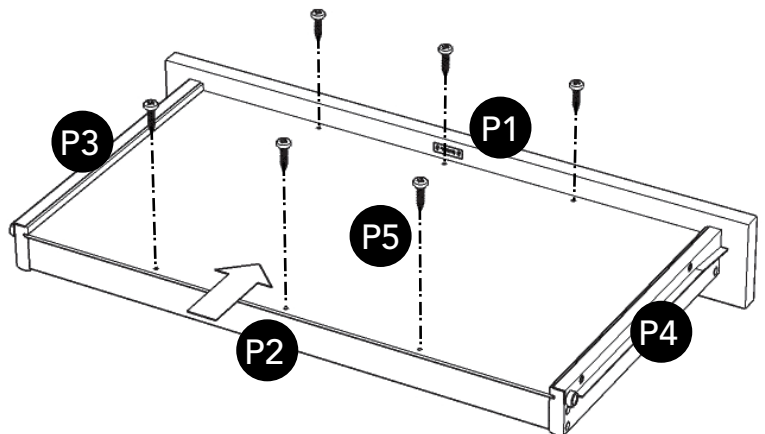

STEP 8

Attach Pull Handle with Machine Screws.

Part List

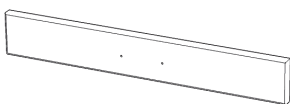

P1.
Drawer Front
1 pc.

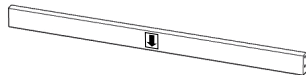

P2.
Drawer Back
1 pc.

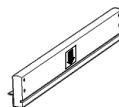

P3.
Drawer Side
1 pc.

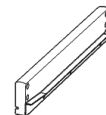

P4.
Drawer Side
1 pc.

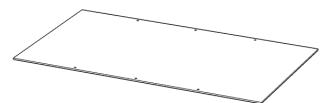

P5.
Drawer Bottom
1 pc.

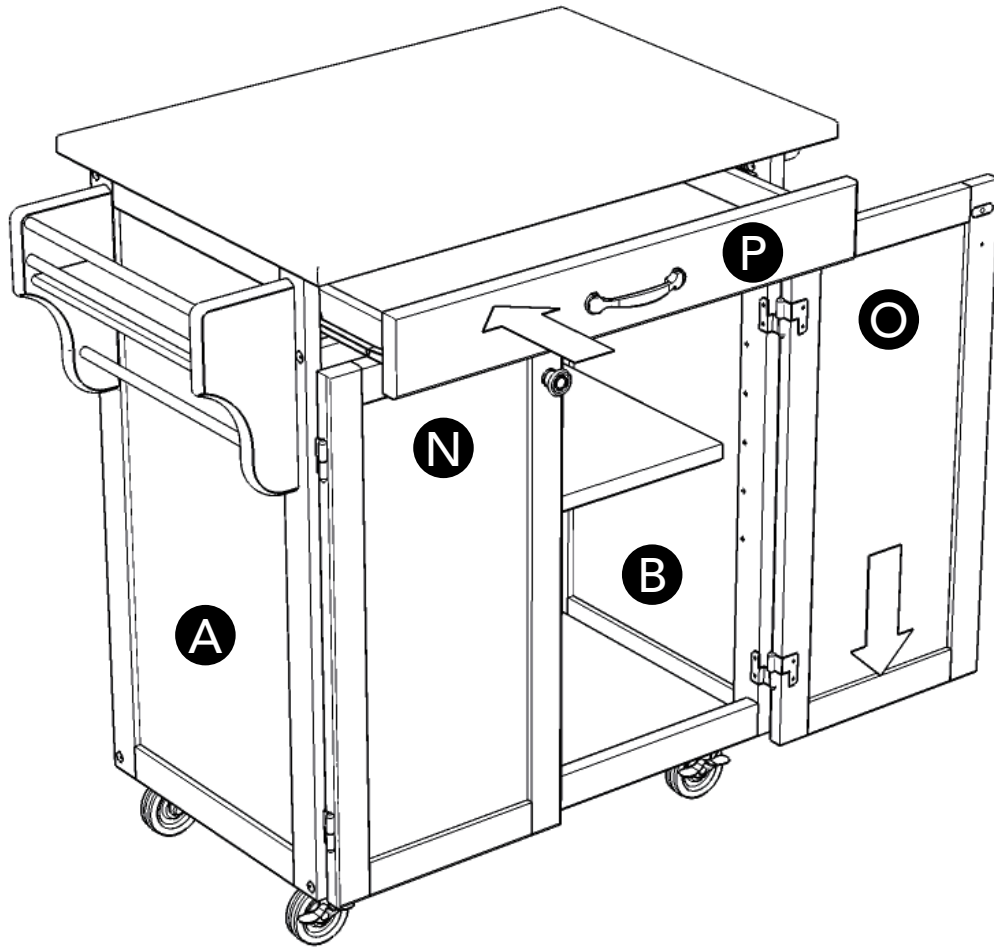

STEP 9

Attach Knobs to Doors (N) and (O) with Machine Screws.
(See Figure 4)

Attach Doors (N) and (O) to unit by sliding the door lift hinges into side panel lift hinges.
(See Figure 5)

Slide Drawer (P) into position.

Cover all holes with Wood Plugs.
(See Figure 6)

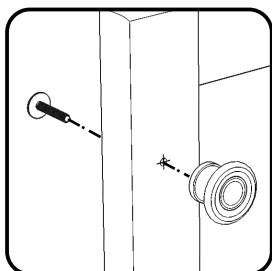

Figure 4

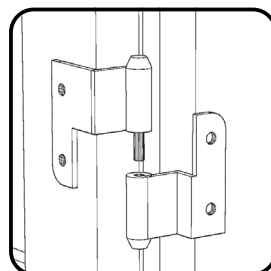

Figure 5

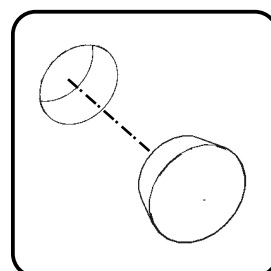

Figure 6

CARE INSTRUCTIONS

NEVER

allow liquids to remain on furniture.
Absorption causes parts to warp
and split and finishes to delaminate.

NEVER

use glass cleaners on
finished furniture. Ammonia
chemically attacks the finish.



Do not use power tools
above 8 volts to assemble.
**PREVENT
CRACKING**



Do not place
in direct sunlight.
**PREVENT
FADING**



Do not write
directly on surface.
**PREVENT
MARKING**



Do not place hot
objects on surface.
**PREVENT
FINISH DAMAGE**

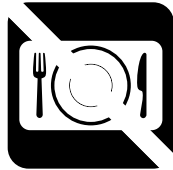

Do not use rubber
based placemats.
**PREVENT
DISCOLORING**



Do not use commercial
waxes and polishes.
**PREVENT
YELLOWING**

CLEAN

with a soft cloth moistened
in lukewarm soap and water.
Buff with a dry clean cloth.



Home Styles will provide replacements free of charge for missing or damaged hardware or parts within 30 days of purchase. Digital images of the defective parts may be required. If the product was not purchased from an authorized retail affiliate, Home Styles is under no obligation to provide replacement parts. Parts are not available for fully assembled items nor are parts available for sale. Replacements for missing or damaged hardware or parts may be requested at:

www.homestyles-furniture.com/customer-service/replacement-parts

Home Styles Customer Service: www.homestyles-furniture.com,
servicedesk@homestyles-furniture.com, 888-680-7460, 877-831-0319