

Assembly Instruction

Item No: U2506 -13
ENZO GLIDER RECLINER

Thank you for purchasing this quality product. Be sure to check all packing materials carefully for small parts, which may have come loose during shipment. Identify and count all items and compare with the parts list shown below.

It is recommended to have two people during unpacking and assembling of the backs and base of the furniture out from the box.

Parts List			
NO.	DESCRIPTION	SKETCH	QTY
A	SEAT		1PC
B	BACKREST		1PC
C	LEFT SIDE FACING (LSF) WING		1PC
D	RIGHT SIDE FACING (RSF) WING		1PC

WEIGHT CAPACITY (PER SEAT) : 350 LBS

Please follow the drawings below to assemble the item

STEP 1: Cut and remove the fasteners on the frame at the bottom of the seat (A).

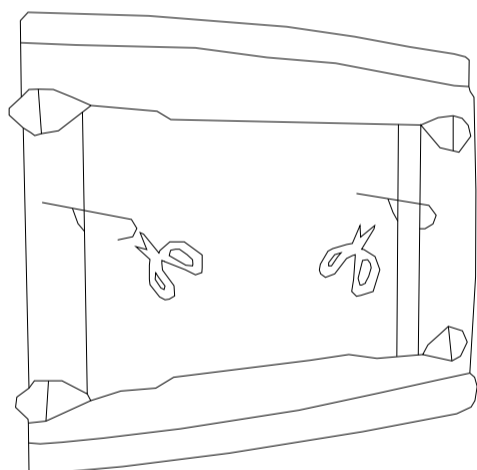

STEP 2: Install the backrest (B) by align and insert the metal bracket on the backrest (B) to the metal bracket of the seat (A). Please make sure the brackets are inserted all the way and secured into position.

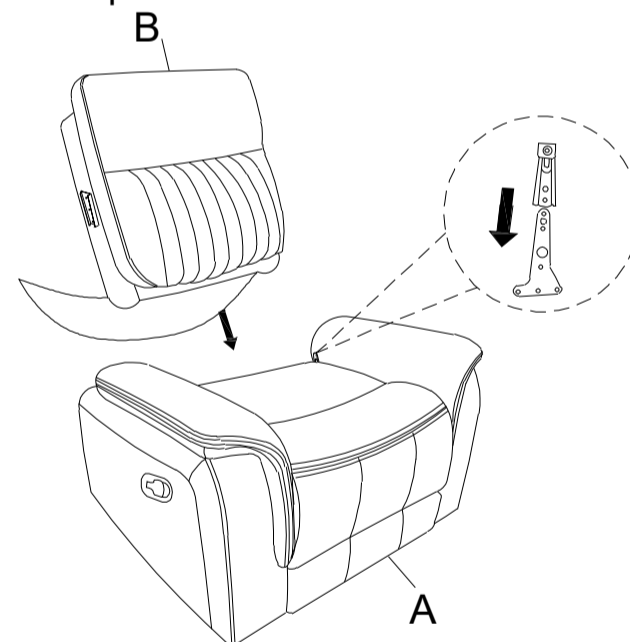

STEP 3: Install the wings by inserting metal bracket on the LSF wing (C) and RSF wing (D) into the metal bracket on the backrest (B). Please make sure the brackets are inserted all the way and secured into position.

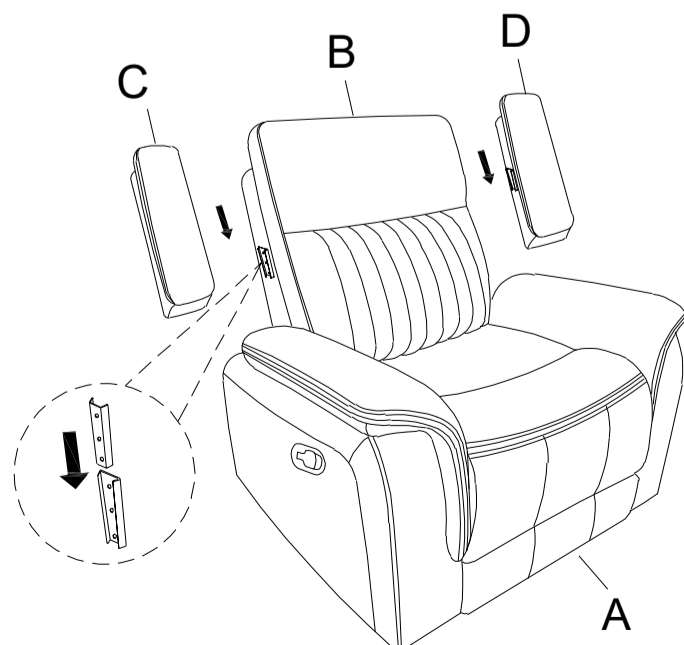

STEP 4: Complete

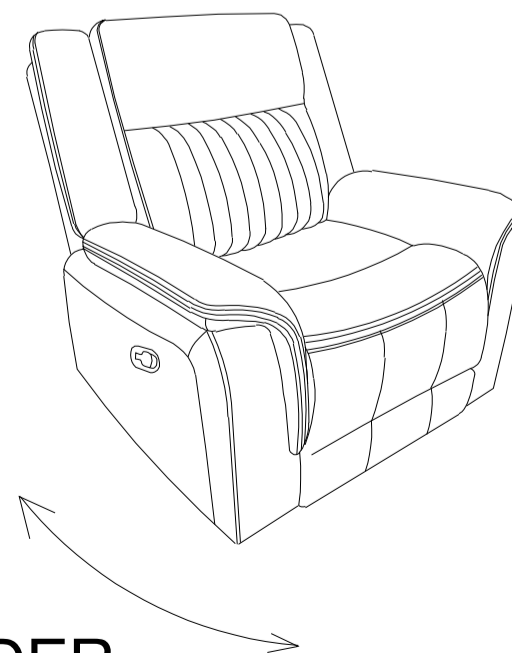

GLIDER