



File MQ1617

Vol 3

Auth. Page 1

Issued: 1994-10-17

Revised: 2019-07-25

FOLLOW-UP SERVICE PROCEDURE  
(TYPE L)

PERSONAL BUOYANT WATER SAFETY PRODUCTS  
(ZDTQC)

Manufacturer: SEE ADDENDUM FOR MANUFACTURER LOCATIONS

Applicant: 414097 (Party Site)  
(184499-001) Mustang Survival Corp  
7525 Lowland Dr  
Burnaby  
BC V5J 5L1 CANADA

Listee: 414097 (Party Site)  
(184499-001) SAME AS APPLICANT

Use of the Mark

This Follow-Up Service Procedure authorizes the above Manufacturer(s) to use the marking specified by Underwriters Laboratories of Canada Inc. ("ULC"), or any authorized licensee of ULC, including the UL Contracting Party, only on products when constructed, tested and found to be in compliance with the requirements of this Follow-Up Service Procedure and in accordance with the terms of the applicable service agreement with UL Contracting Party. The UL Contracting Party for Follow-Up Services is listed in the addendum to this Follow-Up Service Procedure ("UL Contracting Party"). UL Contracting Party and ULC are referred to jointly herein as "UL."

It is the responsibility of the Applicant, Manufacturer(s), and Listee to make sure that only the products meeting the aforementioned requirements bear the authorized Marks of ULC, or any authorized licensee of ULC.

### Additional Responsibilities

Additional responsibilities, duties and requirements for the Applicant and Manufacturers are defined under Additional Resources at the following web-site: <http://www.ul.com/fus>. Manufacturers without Internet access may obtain the current version of these documents from their local ULC customer service representative or ULC field representative. For assistance, or to obtain a paper copy of these documents or the Follow-Up Service Terms referenced below, please contact ULC's Customer Service at <http://www.ul.com/aboutul/locations/>, select a location and enter your request, or call the number listed for that location.

### Acceptance of Follow-Up Services

The Applicant and the specified Manufacturer(s) and any Listee in this Follow-Up Service Procedure must agree to receive Follow-Up Services from UL Contracting Party. If your applicable service agreement is a Global Services Agreement ("GSA"), the Applicant, the specified Manufacturer(s) and any Listee will be bound to a Service Agreement for Follow-Up Services upon the earliest by any Subscriber of a) use of the prescribed ULC Mark, b) acceptance of the factory inspection, or c) payment of the Follow-Up Service fees. The Service Agreement incorporates such GSA, this Follow-Up Service Procedure and the

Follow-Up Service Terms which can be accessed by clicking the following link: <http://services.ul.com/fus-service-terms>. In all other events, Follow-Up Services will be governed by and incorporate the terms of your applicable service agreement and this Follow-Up Service Procedure.

### Use and Ownership of the Follow-Up Service Procedure

This Follow-Up Service Procedure, and any subsequent revisions, is the property of UL and is not transferable. This Follow-Up Service Procedure contains confidential information for use only by the Applicant, the specified Manufacturer(s), and representatives of UL and is not to be used for any other purpose. It is provided to the Subscribers with the understanding that it is not to be copied, either wholly or in part unless specifically allowed, and that it will be returned to UL, upon request.

### Definition of Terms

Capitalized terms used but not defined herein have the meanings set forth in the GSA and the applicable Service Terms or any other applicable UL service agreement.

### No Third Party Liability

UL shall not incur any obligation or liability for any loss, expense or damages, including incidental, consequential or punitive damages arising out of or in connection with the use or reliance upon this Follow-Up Service Procedure to anyone other than the above Manufacturer(s) as provided in the agreement between ULC or an authorized licensee of ULC, including UL Contracting Party, and the Manufacturer(s).

### Certification Body

ULC has signed below solely in its capacity as the certification body to indicate that this Follow-Up Service Procedure fulfills the requirements for certification documentation issued by the certification body.

Gunsimar Paintal  
ULC Mark Certification Program Manager  
Underwriters Laboratories of Canada Inc.

LOCATION

(106700-001) 156608 (Party Site)  
Taicang Bibliogem Sporting Products Co Ltd  
No.19 Fengnan Rd  
Shuang Feng Town  
Taicang  
Jiangsu 215416 CHINA  
Factory ID: Use Label Issue No. for 106700001  
UL Contracting Party for above site is: UL GmbH

(184499-001) 414097 (Party Site)  
Mustang Survival Corp  
7525 Lowland Dr  
Burnaby  
BC V5J 5L1 CANADA  
Factory ID: None  
UL Contracting Party for above site is: Underwriters Laboratories of Canada Inc.

(100581-078) 613971 (Party Site)  
HUAIAN GAIA SPORTING PRODUCTS CO. LTD.  
123 Neng Gjiang Road  
Economic Dev Zone Of Huai Ying  
Huaian  
Jiang Su 223000 CHINA  
Factory ID: Use Label Issue No. for 100581078  
UL Contracting Party for above site is: UL GmbH

MODEL	SECTION
Approved Components List and Seam/Stitching Details	1
B830, B831, B832, MV1203, MV1205, MV1207, MV1233, MV1235, MV1237, MV1245, MV1247	2
<b>WITHDRAWN</b>	3
MV1340, MV1345, MV1350	4
MV3175	5

PERSONAL BUOYANT WATER SAFETY PRODUCTS (ZDTQC)

APPENDIX A

ULC REPRESENTATIVE'S DUTIES AND  
INSTRUCTIONS FOR EXAMINATION OF THE PRODUCT

Table of Contents:

- I. ULC Representative's Duties
- II. ULC Representative's Countercheck Program
  - A. ULC Representative's Test and Inspection Program
    - 1. Visual Examination
    - 2. Review of Records
    - 3. Countercheck Tests - Each Inspection

## PERSONAL BUOYANT WATER SAFETY PRODUCTS (ZDTQC)

## I. ULC REPRESENTATIVE'S DUTIES:

The ULC Representative's duties include, but are not limited to:

1. Examining the construction of production intended to bear the ULC Mark or Marking to determine compliance with the description of the product and any other requirements expressed in this Procedure.
2. Where so specified in App. B, forward samples to ULC for follow-up tests.
3. Inspecting the test records and facilities of the manufacturer to insure that:
  - a. The proper number of samples are undergoing the required tests, and
  - b. The required tests are being performed correctly, and
  - c. The proper information is being recorded and is up-to-date, and
  - d. The instruments being used for the tests have been calibrated at the prescribed interval and are in good working order.
4. Reporting to the manufacturer and Follow-Up Services Department by means of a Variation Notice (VN) if:
  - a. Variations in construction or materials are found, or
  - b. The manufacturer's method and/or frequency of test is not as described, or
  - c. The records maintained by the manufacturer are not as described, or
  - d. The manufacturer's inspection program is not being performed as described, or
  - e. Unacceptable test results are witnessed during tests conducted specifically for the ULC Representative.
  - f. The required test equipment has not been calibrated at the frequency specified in this Appendix.

## PERSONAL BUOYANT WATER SAFETY PRODUCTS (ZDTQC)

Explain to the manufacturer that a VN is a means of communication with the manufacturer and forms a record of those items where non-conformance to the Procedure has been found.

5. When a product does not comply with the Follow-Up Service Procedure, requiring that the manufacturer either shall (1) remove any markings referencing ULC from the product, (2) suitably modify all products that do not comply with the Follow-Up Service Procedure, or (3) hold shipment pending further instructions from Follow-Up Services.

In the event of disagreement between the manufacturer and the ULC Representative as to whether a product is acceptable, the manufacturer shall hold production at the factory pending resolution of the variations. The manufacturer has the right to appeal a decision with which he disagrees and the ULC Representative shall provide the name of the Follow-Up Service engineer to whom the appeal is to be made. Should Follow-Up Services grant temporary authorization for the continued use of the ULC Mark, such temporary authorization shall only be for the time needed to review and/or process the Procedure revisions, or as otherwise specified to cover a particular lot or production run.

## II. ULC REPRESENTATIVE'S COUNTERCHECK PROGRAM:

## A. ULC REPRESENTATIVE'S TEST AND INSPECTION PROGRAM

## 1. Visual Inspection

At each inspection, samples of current production and/or stock, which the manufacturer has previously determined acceptable, shall be examined to determine:

- a. That product contains the required marking as specified in the Procedure.
- b. The product has been assembled and contains all components as specified in the descriptive pages and assembly drawings of the Procedure. Component models and dimensions (if applicable) should be given particular attention.
- c. The pocket dimensions and locations conform to the specified dimensions as in the assembly drawings of the Procedure.

## PERSONAL BUOYANT WATER SAFETY PRODUCTS (ZDTQC)

## 2. Review of Records

At each inspection, the ULC Representative shall review the manufacturer's required records to see that the necessary information is recorded.

## 3. Countercheck Tests - Each Inspection

At each inspection, the ULC Representative shall witness the manufacturer's performance of the tests as outlined in Appendix D and determine that the tests are conducted properly, paying particular attention to see that the proper test conditions are being maintained.



PERSONAL BUOYANT WATER SAFETY PRODUCTS (ZDTQC)

APPENDIX B

INSTRUCTIONS TO THE ULC REPRESENTATIVE  
FOR SAMPLE PICKUP

**RESERVED**

PERSONAL BUOYANT WATER SAFETY PRODUCTS (ZDTQC)

APPENDIX C

FOLLOW-UP TESTS AT ULC

**RESERVED**

PERSONAL BUOYANT WATER SAFETY PRODUCTS (ZDTQC)

APPENDIX D

INSTRUCTIONS FOR  
TEST AND/OR INSPECTION AT THE FACTORY

Table of Contents:

- I. MANUFACTURER'S RESPONSIBILITIES
- II. SAMPLE SELECTION FOR MANUFACTURER'S PRODUCTION EXAMINATIONS AND/OR TESTS
- III. MANUFACTURER'S PRODUCTION EXAMINATIONS AND/OR TESTS
  - A. PRODUCTION EXAMINATION
  - B. BUOYANCY AND BUOYANCY DISTRIBUTION
  - C. FINISHED DEVICE EXAMINATION
  - D. TENSILE STRENGTH TEST
  - E. WISE CHOICE BROCHURE ATTACHMENT STRENGTH TEST
- IV. PROCEDURE IN CASE OF TEST AND/OR EXAMINATION NON-CONFORMANCE
- V. RECORDS TO BE MAINTAINED BY THE MANUFACTURER

## PERSONAL BUOYANT WATER SAFETY PRODUCTS (ZDTQC)

## I. MANUFACTURER'S RESPONSIBILITIES:

It is the manufacturer's responsibility to comply with the requirements in the Procedure. This is to be accomplished in part by maintaining the necessary quality control for component materials, manufacturing methods and finished devices. The following items outline the minimum steps necessary to demonstrate that the product conforms under normal manufacturing conditions. It is understood that the manufacturer must have a continuing program of employee training, equipment maintenance and other quality assurance practices, which keep the product in conformance. Under abnormal conditions, additional examination, inspection, or other steps will be required to ensure product conformance.

The manufacturer's Quality Control Program shall include at least the following:

- a. The source and type of materials and components and invoice numbers. All materials and components must be as shown in the Descriptive Sections of this Procedure unless otherwise noted. ULC Listed components must only be accepted if a ULC Label is attached.
- b. Proof of conformity of materials to the requirements of this Procedure.
- c. The quantity of supplies received and used by lot number.

The manufacturer shall provide and maintain equipment necessary to perform the tests in this Appendix. This equipment shall be calibrated at intervals not exceeding 12 months.

The manufacturer shall maintain a program to assure that testing and measuring equipment used in production and/or inspection is kept clean, is maintained in good working order, and in calibration.

The manufacturer shall maintain certification of this calibration until the next succeeding certification is provided and shall be readily available for review by the ULC representative.

## PERSONAL BUOYANT WATER SAFETY PRODUCTS (ZDTQC)

## II. SAMPLE SELECTION FOR MANUFACTURER'S PRODUCTION EXAMINATIONS AND/OR TESTS

## GENERAL

The manufacturer or the ULC Representative shall select samples for tests, at random from each lot.

## DESIGNATION OF LOTS

The manufacturer shall start a new lot with each change in run, material used, model or sizes. Each lot shall be identified with the lot designation. The manufacturer shall maintain records for each lot. The number of samples indicated in the production tests is for one lot only.

An equal number of samples shall be provided for each additional lot to be tested.

## III. MANUFACTURER'S PRODUCTION EXAMINATIONS AND/OR TESTS

## A. PRODUCTION EXAMINATION

The product quality shall be checked at each point in the manufacturing process where irreversible changes are made to the raw materials and partly finished product. Records of rejections and corrective actions shall be maintained by lot number.

The inspection shall include:

- a. At least one sample set of buoyancy panels (including fabric laminated neoprene if applicable) is to be checked against the requirements of this Procedure for each lot prior to continuing with production. Use equipment as outlined in buoyancy and buoyancy distribution test on next page.
- b. Seam allowances.
- c. Stitch size, thread tensions and finishing.
- d. Attachment of belts, buckles and adjusters.
- e. Operation of zippers.

## PERSONAL BUOYANT WATER SAFETY PRODUCTS (ZDTQC)

## BASIS FOR ACCEPTABILITY

Results of the sample inspection are to be recorded to verify (1) compliance with the specifications in the descriptive section(s) of this Procedure; (2) that first-class workmanship is inherent in the product; and (3) that the product is free from defects which may materially affect the appearance or serviceability.

Products considered "seconds" or "irregulars" must not be accepted. A product with surface imperfections such as colour deficiencies, or with other minor defects in optional or decorative features, is generally not considered as seconds or irregulars if it complies with all other requirements. However, it may not have any marking indicating that it has imperfections. Acceptance of questionable product is to be cleared by a Follow-Up Services Department Field Engineer.

## B. BUOYANCY AND BUOYANCY DISTRIBUTION

## SAMPLES

At least one set of front, back and collar buoyancy inserts from each lot before device assembly. If Applicable; Fabric Laminated Neoprene may not be included in the buoyancy of the device. If a lot consists of more than 500 devices, at least one set of front and back buoyancy inserts is to be selected per 500 devices.

## TEST EQUIPMENT

The following equipment is required for this test:

- a. Mesh basket large enough to hold the device and sufficiently weighted to overcome its buoyancy.
- b. Tank of fresh water large enough to contain the basket submerged with its top edge at least 50 mm below the surface and to allow the submerged basket to be manipulated to remove entrapped air.
- c. Scale or load cell that has an accuracy of  $\pm 25$  g (1 oz) and is arranged to support the basket in the tank and to determine its mass.

## METHOD

Place, in turn, front, back and collar buoyancy inserts in an individual weighted cage and suspend it in fresh water so that the cage is completely submerged with minimum of 50 mm between the top of the cage and the water surface.

## PERSONAL BUOYANT WATER SAFETY PRODUCTS (ZDTQC)

Ensure that the buoyant material tested in this manner is not unduly compressed during the test period and is so placed in the cage as to permit the free escape of entrapped air. The inserts should be agitated to help free entrapped air.

The inserts shall remain submerged for a period of at least 1 hour after agitation. Determine the mass of the cage and buoyancy inserts.

Calculate the buoyant force by subtracting the submerged weight of the weighted cage alone when submerged to the same depth. Determine the measured buoyancy in Newton's (1 kgf = 9.807 Newton's).

The measured buoyancy must be adjusted for water temperature and atmospheric pressure using one of the following formulas (or similar formula using manufacturer's applicable equipment units of measurement), if the tank water temperature is not at  $20^{\circ}\text{C} \pm 3^{\circ}\text{C}$  during the test, or the Atmospheric Pressure is not  $101.3 \text{ kPa} \pm 3 \text{ kPa}$ .

$$\text{a) Corrected buoyancy} = \text{Measured buoyancy} \times (P/101.3) \times (293/(T+273))$$

Where; P = Pressure (kPa)  
T = Temperature (Degree Celsius)

$$\text{b) Corrected buoyancy} = \text{Measured buoyancy} \times (P/760) \times (528/(T+460))$$

Where; P = Pressure (mm of Hg)  
T = Temperature (Degree Fahrenheit)

## BASIS OF ACCEPTABILITY

The corrected buoyancy (compare with minimum production total buoyancy) and buoyancy distribution values shall be equal to or above those specified in the descriptive section(s) of the Procedure for each model.

## C. FINISHED DEVICE EXAMINATION

At least one sample is to be selected from each 500 finished units. This sample is to be compared with the requirements of the Product Description as shown in this Procedure. If any discrepancy is noted, a further 10 samples are to be selected and examined. A discrepancy noted in the second sampling constitutes rejection of the lot.

## PERSONAL BUOYANT WATER SAFETY PRODUCTS (ZDTQC)

## D. TENSILE STRENGTH TEST

## SAMPLES

For every lot, at least one sample (any size: Infant, Child or Youth) is to be selected from each 500 finished units.

## METHOD

## TENSILE - VERTICAL LOAD

For this test, one of the setups as shown in the following three diagrams is to be used. The device is to be fitted to the form and all forms of adjustment (i.e. zippers, body belts, etc.) are tightened firmly. With the device supported by a 75 mm strap with a 6 mm foam covering placed under the shoulder strap, a weight is to be applied to the lower frame member. The total mass of frame and weight is to be 34 kg (75 lbs). The load is to be raised from the floor and maintained for 2 minutes.

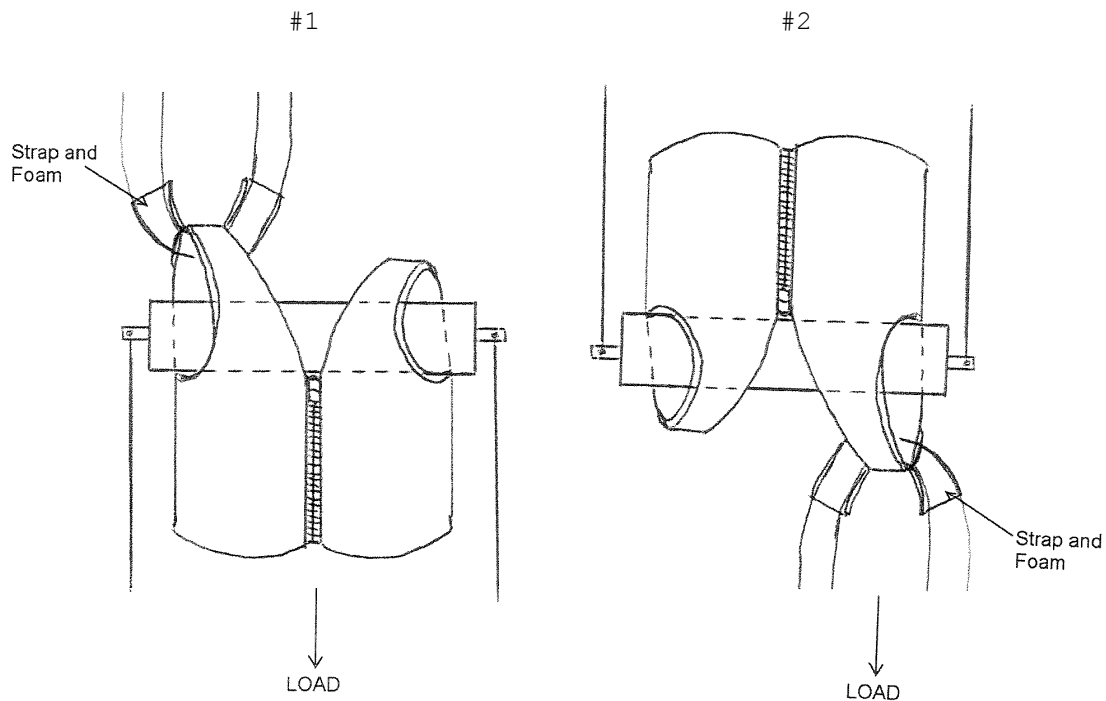



PERSONAL BUOYANT WATER SAFETY PRODUCTS (ZDTQC)

TENSILE STRENGTH TEST (CONTINUED):

TEST FORM

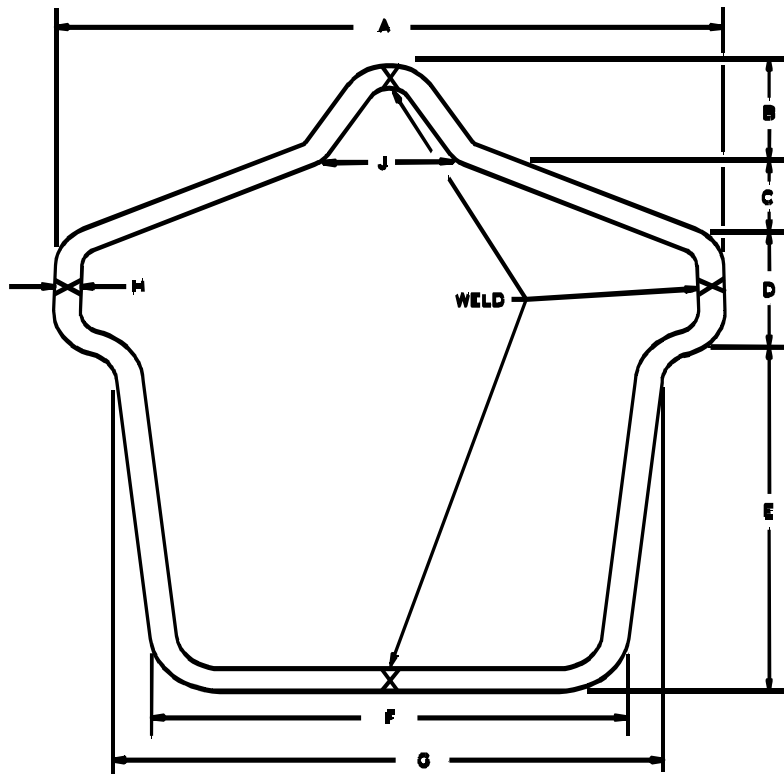

Size	Dimension	A	B	C	D	E	F	G	H	J
Infant	(mm)	305	63.5	38.1	63.5	191	203	241	19.1	76.2
Child	(mm)	330	76.2	50.8	76.2	229	254	292	19.1	102
Youth	(mm)	508	102	76.2	102	279	330	406	22.2	152

## PERSONAL BUOYANT WATER SAFETY PRODUCTS (ZDTQC)

## TENSILE STRENGTH TEST (CONTINUED):

## TENSILE - HORIZONTAL LOAD

For this test, the Tensile Test Apparatus as shown in the following diagram and described below is to be used. The apparatus is comprised of two cylinders, each with a diameter of 50 mm and a length sufficient to freely support the device, and a means of support/attachment. The webbing is to be adjusted to the midway point of adjustment. With the device supported by the top cylinder, a weight is to be attached to the bottom cylinder so that the required load is applied to the device. The total load of 72 kg (159 lbs) is to include the weight, its attachment means, and the bottom cylinder. The load is to be raised from the floor and maintained for 5 minutes duration.

## TENSILE TEST APPARATUS

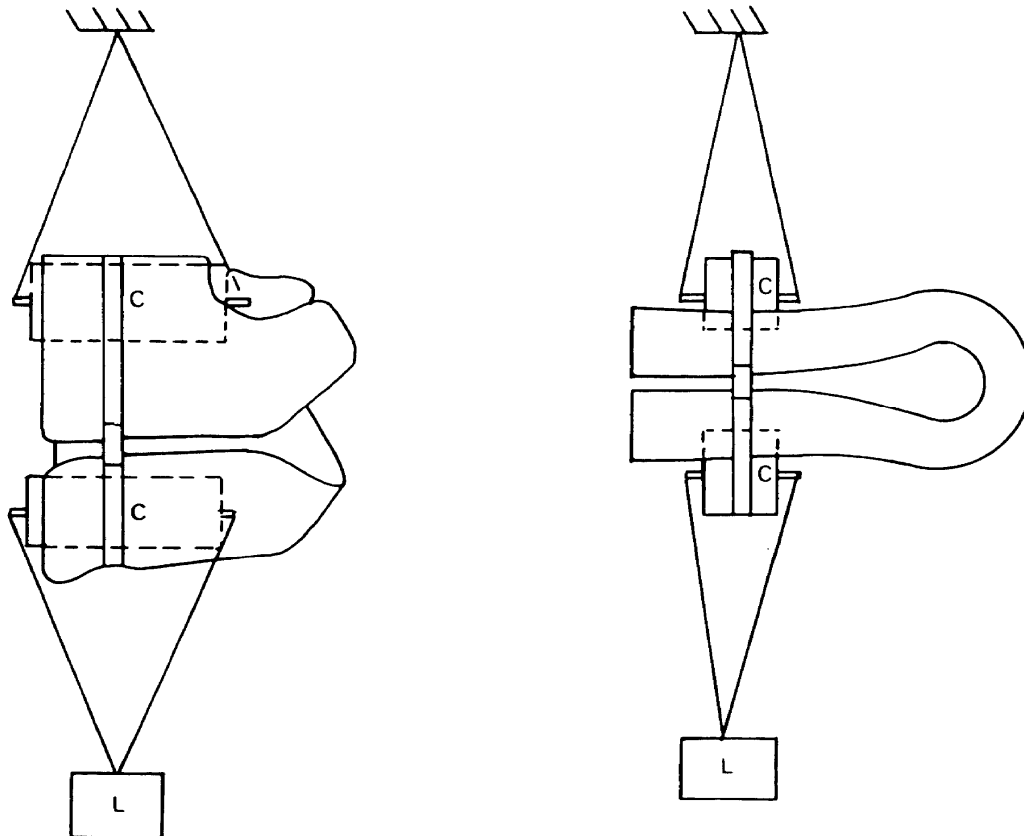

## PERSONAL BUOYANT WATER SAFETY PRODUCTS (ZDTQC)

## TENSILE STRENGTH TEST (CONTINUED):

For devices having more than one body strap, the test is to be repeated so as to evaluate each body strap independent of other closures (i.e. other body straps, zippers). For devices, which incorporate a zipper as a front closure, the test is to be repeated so as to evaluate the zipper independent of other closures (i.e. other body straps).

If any discrepancy is noted, a further 10 samples are to be selected and examined. A discrepancy noted in the second sampling constitutes rejection of the lot.

## BASIS OF ACCEPTABILITY

The sample shall hold the load with no evidence of deterioration or impaired operation of the device. EACH SAMPLE SUBJECTED TO THE TENSILE STRENGTH TEST SHALL BE RENDERED UNUSABLE AND DISCARDED FOLLOWING TESTING.

## E. WISE CHOICE BROCHURE ATTACHMENT STRENGTH TEST

## SAMPLES

For every lot, at least one sample is to be selected from each 500 finished units.

## METHOD

A sample PFD was secured in a vertical normally oriented position with the information pamphlet "Wise Choice Brochure" attached by means of a hangtag fastener.

A 1.8 kg mass was attached to the pamphlet and allowed to hang freely for 1 min.

## BASIS OF ACCEPTABILITY

The pamphlet remained attached to the device and undamaged.

## PERSONAL BUOYANT WATER SAFETY PRODUCTS (ZDTQC)

## IV. PROCEDURE IN CASE OF NON-CONFORMANCE TEST AND/OR EXAMINATIONS

Lots from which samples are taken which do not conform to the requirements in this Procedure within the required tolerances shall not be marked with the ULC Listing Mark. It shall be necessary to obtain clearance from a Responsible Reviewing Office Personnel, if the manufacturer desires to rework a lot and/or submit a lot for additional investigation to obtain acceptance for marking and shipment of the lot with the ULC Listing Mark.

## V. RECORDS TO BE MAINTAINED BY THE MANUFACTURER

The manufacturer shall keep comprehensive records for at least five years from the date of manufacture, to provide the capability to:

- A. Assure that materials of acceptable quality are used; and
- B. Enable further testing of samples from questionable lots; and
- C. Immediately trace the cause of any non-conformance and take the necessary corrective action.

The records shall be made available to the Laboratories upon request and shall include, but not be limited to, the following:

- A. Records of calibration for test equipment, which include identity of agency responsible for calibration, date of calibration and results.
- B. Records for all test and product inspection should include sample and lot identification, date of test and/or inspection and test result values. Where non-conformance is indicated, the records shall include the cause of non-conformance, corrective action when taken, and/or the final disposition of the lot.
- C. Records of receipt of materials from suppliers, which include quantities, origin, date and lot identification.
- D. Records of shipment, which include quantities, destination, date and lot identification.

## LABELS (APPROVAL AND ISSUE NUMBERS):

The Applicant is required to have their label design covering the REQUIRED MARKINGS reviewed and approved by the Label Center before labelling may commence.

If a new manufacturing location has been added to the file, the Applicant must contact the Label Center for the Issue Number.

Please use one of the following methods to contact the Label Center:

Email: labelcenter.usa@us.ul.com

Phone: 877-854-3577 Ext. 43030

If the approved Label design is modified, the Label must again be reviewed and approved.

Each device covered in this File shall be permanently (waterproof ink) and clearly marked in a colour, which contrasts with the colour of the surface on which the markings are applied. These markings shall lie entirely in one area and shall be applied by silk-screening, stamping or stencilling directly on the inside surface of the device. Labels printed on spun-bonded paper shall be permanently affixed with thread on all sides of the label to the inside of the device.

## REQUIRED MARKINGS:

Each Infant/Child/Youth personal flotation device will bear a ULC label including the following information:



LISTED/HOMOLOGUÉ  
Personal Flotation Device  
Vêtement de Flottaison Individuel  
Issue No./ No. d'émission <sup>1</sup>

Together with the Listee's name and address.

<sup>1</sup> Issue No. for the applicable Manufacturing Plant location will be assigned during Label review/orders by the Label Center.

The device will also bear a permanent marking including the following information in English and French.

Model name or number (as shown in the applicable Description sections)  
+ Size: \_\_\_ Mass Range: \_\_\_ to \_\_\_ kg  
Month and Year of Manufacture (as an option, this may be clearly included in the Lot Number)  
Lot Number: \_\_\_ to conform to Standard CAN/CGSB-65.15-M88  
+ Buoyancy \_\_\_ N minimum

-AUTHORIZATION FOR IN-HOUSE PRINTING AND USE OF A  
PERMANENT ISSUE NUMBER-

(THIS PAGE IS TO BE REVISED BY THE LABEL DEPARTMENT ONLY)

The following manufacturing facilities are authorized to print UL Marks "In-House" and to use a permanent issue number as described below:

The UL Mark shall include the appropriate UL Logo, the product identification, a date code consisting of the year and month at a minimum, and the issue number corresponding to the appropriate label part no. as follows:

Subscriber No.	Account-Class-Code- UL Label Part No.	Issue No.
184499-001	0160-60-03-74868	L-7123

Date code exception: A date code is not required to be part of the UL Mark when this Follow-Up Service Procedure already requires a production date code to be marked on the product.

When printing the UL Mark on a label, the UL Mark shall be printed with indelibly applied ink. This specification shall be waived only when the UL mark is combined with other Procedure required markings, and printed on a UL Recognized Component Marking and Labeling System as required in this Procedure.

The Field Representative shall report usage of UL Marks to the responsible UL Label Center for the above authorized manufacturing locations. The reported periods shall begin a day after the last day for the previously reported period.

The Field Representative shall periodically review the manufacturer's production recording method to confirm that the manufacturer is accurately and appropriately maintaining usage records of the UL Mark. The Field Representative shall report immediately to the UL Label Center any significant changes in the manufacturer's production recording method and the ability to adequately control and accurately record usage of the UL Mark.

-AUTHORIZATION FOR IN-HOUSE PRINTING AND USE OF A  
PERMANENT ISSUE NUMBER-

(THIS PAGE IS TO BE REVISED BY THE LABEL DEPARTMENT ONLY)

The following manufacturing facilities are authorized to print UL Marks "In-House" and to use a permanent issue number as described below:

The UL Mark shall include the UL Logo, the word (LISTED) in CAPITALS, the product identification, a date code consisting of the year and month at a minimum, and the issue number corresponding to the appropriate label part no. as follows:

Customer No. (Subscriber No.)	UL Label Item No.	Lot No. (Issue No.)
244254 (106700-001)	50026228	0015608
745680 (100581-078)	50026243	0015712

Date code exception: A date code is not required to be part of the UL Mark when this Follow-Up Service Procedure already requires a production date code to be marked on the product.

When printing the UL Mark on a label, the UL Mark shall be printed with indelibly applied ink applied to tamperproof adhesive-backed label material.

This specification shall be waived only when the UL mark is combined with other Procedure required markings, and printed on a UL Recognized Component Marking and Labeling System as required in this Procedure.

The Field Representative shall report usage of UL Marks to the responsible UL Label Center for the above authorized manufacturing locations using a work ticket on a monthly basis. The reported periods shall begin a day after the last day for the previously reported period.

The Field Representative shall periodically review the manufacturer's production recording method to confirm that the manufacturer is accurately and appropriately maintaining usage records of the UL Mark. The Field Representative shall report immediately to the UL Label Center any significant changes in the manufacturer's production recording method and the ability to adequately control and accurately record usage of the UL Mark.

Department of Transport (Canada) Approved  
 Approval Number: (Insert number associated with Model and/or size as shown in the applicable Section of this File)

THIS PFD IS DESIGNED TO BE WORN, WEAR IT.

CAUTION:

1. This device may lose buoyancy over a period of time and become no longer serviceable. The in-water performance should be checked regularly during each season to determine that it provides adequate buoyancy for your needs.
2. Orange, red and yellow coloured PFD are recommended for higher visibility.

NOTICE TO PARENTS:

Parents are reminded that this device is not a substitute for adult supervision.

Modèle: (name or number as shown in the applicable Description sections)

- + Taille: \_\_\_ Masse: \_\_\_ à \_\_\_ kg  
 Mois et année de construction (option: cette information pourrait être incluse clairement dans le numéro de lot)  
 Numéro du lot \_\_\_ selon la norme CAN/CGSB-65.15-M88  
 + Flottabilité minimale, \_\_\_ N

Ministère des Transports (Canada) Approuvé  
 N° d'approbation: (Insert number associated with Model and/or size)

CE VÊTEMENT EST CONÇU POUR VOTRE SÉCURITÉ, PORTEZ-LE!

AVERTISSEMENT:

1. Ce vêtement peut perdre de sa flottabilité après un certain temps et devenir inutilisable. Sa tenue en service dans l'eau devrait donc être vérifiée régulièrement au cours de chaque saison afin de s'assurer que la flottabilité offerte convient aux besoins des utilisateurs.
2. Les V.F.I. de couleur orange, rouge ou jaune sont recommandés pour une meilleure visibilité.

AVIS AUX PARENTS

Ce vêtement ne peut pas remplacer la surveillance par un adulte.

Together with a diagram showing how the PFD is to be worn.

The information in the following table must be included on the ULC label in the above lines marked with a + sign.

Size/Taille	Mass/Masse	Buoyancy/Flottabilité (min.)
Youth/Jeune or B	27-41 kg	44 N
Child/Enfant or C	14-27 kg	36 N
Infant/Jeune enfant or D	9-14 kg	27 N

Note: Each size designation must relate to a specific mass and buoyancy as shown above.

Note: Other Markings may be added at Manufacturer's discretion provided that they do not contradict or confuse the required markings.



MARKINGS FOR USE WITH OPTIONAL FEATURES (DOES NOT NEED TO BE INCORPORATED IN THE REQUIRED MARKINGS LABEL, MAY BE A SEPARATE SEWN LABEL/SILKSCREEN):

For devices incorporating D-rings, O-rings or tabs as optional features (listed out in Sec. 1 of this Volume), the following marking in English and French shall be permanently marked on the device:

"THIS DEVICE IS NOT TO BE FASTENED TO THE BOAT"

"CET APPAREIL NE DOIT PAS ÊTRE ARRIMÉ AU BATEAU"

INFORMATION BROCHURE:

Each PFD shall have the "WISE CHOICE BROCHURE" securely attached to the device. An electronic version of this brochure may be obtained from ULC or Department of Transport Canada.

If a different brochure is to be used, it must contain all of the "WISE CHOICE BROCHURE" information and be approved for use by the Department of Transport Canada.

OPTIONAL MARKINGS:

Logos, Emblems, Heat Transfers, or Silk Screens - The application of these markings shall be such that they do not:

- a. Affect the integrity of the device,
- b. Affect the visibility or readability of the required markings, and
- c. Provide any information contradicting the required markings.

Heat transfers shall be of the low temperature type.

**LISTEE OR MANUFACTURER'S NAME AND ADDRESS:**

The Listee or manufacturer's name and address, where specified in the ULC label shall be one of the following:

**MUSTANG SURVIVAL 7525 LOWLAND DR, BURNABY, BC V5J-5L1, CANADA and/or  
MUSTANG SURVIVAL toll free: 1-800-526-0532, email:  
custserv@mustangsurvival.com, www.mustangsurvival.com (IN ANY ORDER)**

File MQ1617  
Project 07CA18342  
Project 07CA33157  
Project 08CA55280

Issued: May 26, 2007  
Revised: **March 17, 2011**

REPORT

on

PERSONAL BUOYANT WATER SAFETY PRODUCTS  
(ZDTQC)

MUSTANG SURVIVAL CORP  
**BURNABY**, BC, CANADA

Copyright © 2007 Underwriters' Laboratories of Canada

Underwriters' Laboratories of Canada authorizes the above-named company to reproduce this Report provided it is reproduced in its entirety.

## DESCRIPTION

## DEVICE COVERED:

Personal Flotation Device for Children (PFD); Models:  
 B830, MV1203, MV1233 (Infant);  
 B831, MV1205, MV1235, MV1245 (Child); and  
 B832, MV1207, MV1237, MV1247 (Youth).

These devices are designed to be worn in and out of the water, or on the water surface, to provide increased survival possibility in the event of exposure to drowning risks.

All models covered by this section are inherently buoyant, non-reversible vests that have the following features:

- Front zipper.
- 1 Body Belt.
- Crotch Strap.
- Collar with Handle.

See Illustration 1 for General Appearance.

Model	Size	Made for Persons Weighing (Kg.)	Department of Transport Canada Approval Number
B830, MV1203, MV1233	D (Infant)	9 - 14	A29-19-22
B831, MV1205, MV1235, MV1245	C (Child)	14 - 27	A29-19-22
B832, MV1207, MV1237, MV1247	B (Youth)	27 - 41	A29-19-22

## COMPLIANCE:

The products described herein have been investigated to, and found in compliance with, the Standard for Personal Flotation Devices for Children, CAN/CGSB-65.15-M88.

## MARKING:

See Section General in this Volume for requirements.

## CONSTRUCTION DETAILS:

## MINIMUM TOTAL PRODUCTION BUOYANCY AND DISTRIBUTIONS

Production devices must meet the values as specified in the following table. Devices employing flotation foam materials with a V-Factor of less than 95 must adjust the minimum production total buoyancy using the calculation under Flotation Foam in Section 1 of this Volume.

Model	Size	Minimum Production Total Buoyancy (N)	Minimum Production Front Distribution (%)	Minimum Production Front and Collar Distribution (%)
B830, MV1203, MV1233	D (Infant)	28.8	61.0	81.0
B831, MV1205, MV1235, MV1245	C (Child)	38.7	61.0	81.0
B832, MV1207, MV1237, MV1247	B (Youth)	44.1	61.0	81.0

## COMPONENTS

Approved components used in the construction of the PFD covered by this Section are covered in Section 1 of this Volume.

## STRUCTURAL SEAMS AND STITCHING

Approved seams/stitches are illustrated in Section 1 of this Volume.

## POCKETS

These devices have no pockets.

## ILLUSTRATION INDEX

<u>ILL. No.</u>	<u>Description</u>
1	General Assembly
2	Assembly Detail - Sec. A-A
3	Assembly Detail - Sec. B-B, Sec. C-C & Sec. D-D
4	Infant size - Front Foam Patterns
5	Infant size - Back Foam Patterns
6	Infant size - Collar Centre Foam Patterns
7	Infant size - Collar Sides Foam Patterns
8	Child size - Front Foam Patterns
9	Child size - Back Foam Patterns
10	Child size - Collar Centre Foam Patterns
11	Child size - Collar Sides Foam Patterns
12	Youth size - Front Foam Patterns
13	Youth size - Back Foam Patterns
14	Youth size - Collar Centre Foam Patterns
15	Youth size - Collar Sides Foam Patterns
16	B830, B831 & B832 Shell Fabric Patterns
17	MV1203, MV1205 & MV1207 Shell Fabric Patterns
18	MV1233, MV1235 & MV1237 Shell Fabric Patterns
19	MV1245 & MV1247 Shell Fabric Patterns
20	Lining Fabric Patterns

REV	DESCRIPTION	DATE	BY
A	DESIGN FOR THE MUSTANG SURVIVAL GORP. (SEE ILL. 1)		
B	REVISION TO ADD ELASTIC STRAP TO THE GORP. (SEE ILL. 2)		
C	REVISION TO ADD ELASTIC STRAP TO THE GORP. (SEE ILL. 3)		

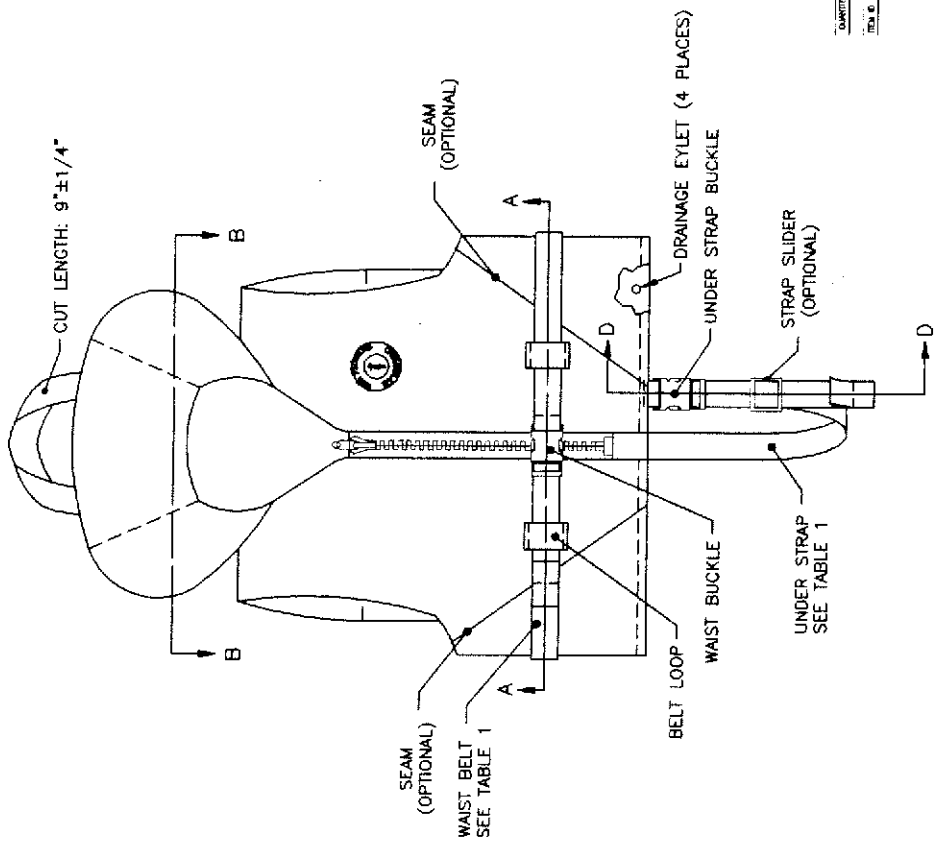
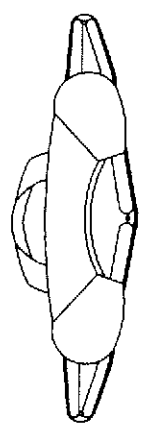
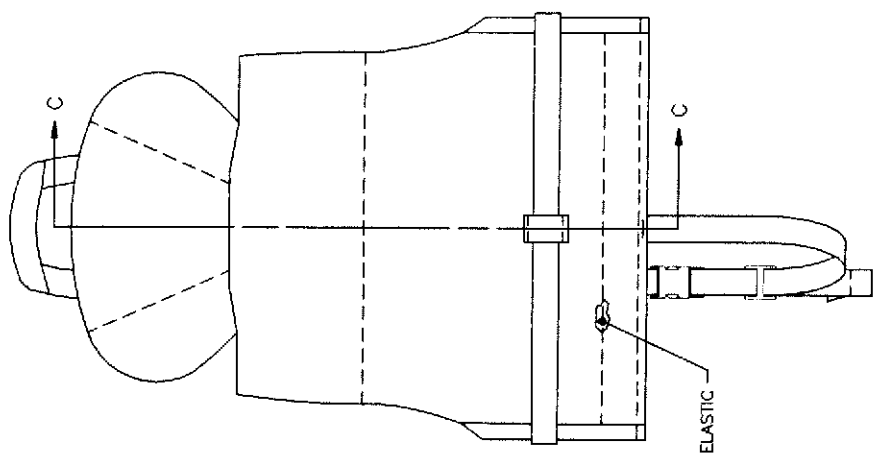

TABLE 1 - WEAVING CUT LENGTHS

STYLES	UNDER STRAP (GROUCH STRAP)
B830, M41200, M41233	21" ± 1/2"
B831, M41205, M41235, M41245	38" ± 3/4"
B832, M41207, M41237, M41247	29" ± 3/4"

QUANTITY	ITEM NO.	PART OR IDENTIFYING NO.	DESCRIPTION	UNIT OF MEASURE
			MUSTANG SURVIVAL GORP.	
			GENERAL ILLUSTRATION MODELS:	
			B830, B831, B832, M41203, M41205, M41233, M41235, M41237, M41245	
			DATE: 12/27/53	
			BY: D. J. F. (5)	
			31M4017	

THE DRAWING IS THE PROPERTY OF MUSTANG SURVIVAL CORP. (INCORPORATED, U.S.A.) AND IS NOT TO BE REPRODUCED OR COPIED IN ANY MANNER WITHOUT THE WRITTEN CONSENT OF MUSTANG SURVIVAL CORP. (INCORPORATED, U.S.A.).

REV.	DATE	DESCRIPTION
1	10/15/68	DESIGN DEVELOPMENT
2	11/15/68	DESIGN DEVELOPMENT
3	12/15/68	DESIGN DEVELOPMENT
4	1/15/69	DESIGN DEVELOPMENT
5	2/15/69	DESIGN DEVELOPMENT
6	3/15/69	DESIGN DEVELOPMENT
7	4/15/69	DESIGN DEVELOPMENT
8	5/15/69	DESIGN DEVELOPMENT
9	6/15/69	DESIGN DEVELOPMENT
10	7/15/69	DESIGN DEVELOPMENT
11	8/15/69	DESIGN DEVELOPMENT
12	9/15/69	DESIGN DEVELOPMENT
13	10/15/69	DESIGN DEVELOPMENT
14	11/15/69	DESIGN DEVELOPMENT
15	12/15/69	DESIGN DEVELOPMENT
16	1/15/70	DESIGN DEVELOPMENT
17	2/15/70	DESIGN DEVELOPMENT
18	3/15/70	DESIGN DEVELOPMENT
19	4/15/70	DESIGN DEVELOPMENT
20	5/15/70	DESIGN DEVELOPMENT
21	6/15/70	DESIGN DEVELOPMENT
22	7/15/70	DESIGN DEVELOPMENT
23	8/15/70	DESIGN DEVELOPMENT
24	9/15/70	DESIGN DEVELOPMENT
25	10/15/70	DESIGN DEVELOPMENT
26	11/15/70	DESIGN DEVELOPMENT
27	12/15/70	DESIGN DEVELOPMENT
28	1/15/71	DESIGN DEVELOPMENT
29	2/15/71	DESIGN DEVELOPMENT
30	3/15/71	DESIGN DEVELOPMENT
31	4/15/71	DESIGN DEVELOPMENT
32	5/15/71	DESIGN DEVELOPMENT
33	6/15/71	DESIGN DEVELOPMENT
34	7/15/71	DESIGN DEVELOPMENT
35	8/15/71	DESIGN DEVELOPMENT
36	9/15/71	DESIGN DEVELOPMENT
37	10/15/71	DESIGN DEVELOPMENT
38	11/15/71	DESIGN DEVELOPMENT
39	12/15/71	DESIGN DEVELOPMENT
40	1/15/72	DESIGN DEVELOPMENT
41	2/15/72	DESIGN DEVELOPMENT
42	3/15/72	DESIGN DEVELOPMENT
43	4/15/72	DESIGN DEVELOPMENT
44	5/15/72	DESIGN DEVELOPMENT
45	6/15/72	DESIGN DEVELOPMENT
46	7/15/72	DESIGN DEVELOPMENT
47	8/15/72	DESIGN DEVELOPMENT
48	9/15/72	DESIGN DEVELOPMENT
49	10/15/72	DESIGN DEVELOPMENT
50	11/15/72	DESIGN DEVELOPMENT
51	12/15/72	DESIGN DEVELOPMENT
52	1/15/73	DESIGN DEVELOPMENT
53	2/15/73	DESIGN DEVELOPMENT
54	3/15/73	DESIGN DEVELOPMENT
55	4/15/73	DESIGN DEVELOPMENT
56	5/15/73	DESIGN DEVELOPMENT
57	6/15/73	DESIGN DEVELOPMENT
58	7/15/73	DESIGN DEVELOPMENT
59	8/15/73	DESIGN DEVELOPMENT
60	9/15/73	DESIGN DEVELOPMENT
61	10/15/73	DESIGN DEVELOPMENT
62	11/15/73	DESIGN DEVELOPMENT
63	12/15/73	DESIGN DEVELOPMENT
64	1/15/74	DESIGN DEVELOPMENT
65	2/15/74	DESIGN DEVELOPMENT
66	3/15/74	DESIGN DEVELOPMENT
67	4/15/74	DESIGN DEVELOPMENT
68	5/15/74	DESIGN DEVELOPMENT
69	6/15/74	DESIGN DEVELOPMENT
70	7/15/74	DESIGN DEVELOPMENT
71	8/15/74	DESIGN DEVELOPMENT
72	9/15/74	DESIGN DEVELOPMENT
73	10/15/74	DESIGN DEVELOPMENT
74	11/15/74	DESIGN DEVELOPMENT
75	12/15/74	DESIGN DEVELOPMENT
76	1/15/75	DESIGN DEVELOPMENT
77	2/15/75	DESIGN DEVELOPMENT
78	3/15/75	DESIGN DEVELOPMENT
79	4/15/75	DESIGN DEVELOPMENT
80	5/15/75	DESIGN DEVELOPMENT
81	6/15/75	DESIGN DEVELOPMENT
82	7/15/75	DESIGN DEVELOPMENT
83	8/15/75	DESIGN DEVELOPMENT
84	9/15/75	DESIGN DEVELOPMENT
85	10/15/75	DESIGN DEVELOPMENT
86	11/15/75	DESIGN DEVELOPMENT
87	12/15/75	DESIGN DEVELOPMENT
88	1/15/76	DESIGN DEVELOPMENT
89	2/15/76	DESIGN DEVELOPMENT
90	3/15/76	DESIGN DEVELOPMENT
91	4/15/76	DESIGN DEVELOPMENT
92	5/15/76	DESIGN DEVELOPMENT
93	6/15/76	DESIGN DEVELOPMENT
94	7/15/76	DESIGN DEVELOPMENT
95	8/15/76	DESIGN DEVELOPMENT
96	9/15/76	DESIGN DEVELOPMENT
97	10/15/76	DESIGN DEVELOPMENT
98	11/15/76	DESIGN DEVELOPMENT
99	12/15/76	DESIGN DEVELOPMENT
100	1/15/77	DESIGN DEVELOPMENT

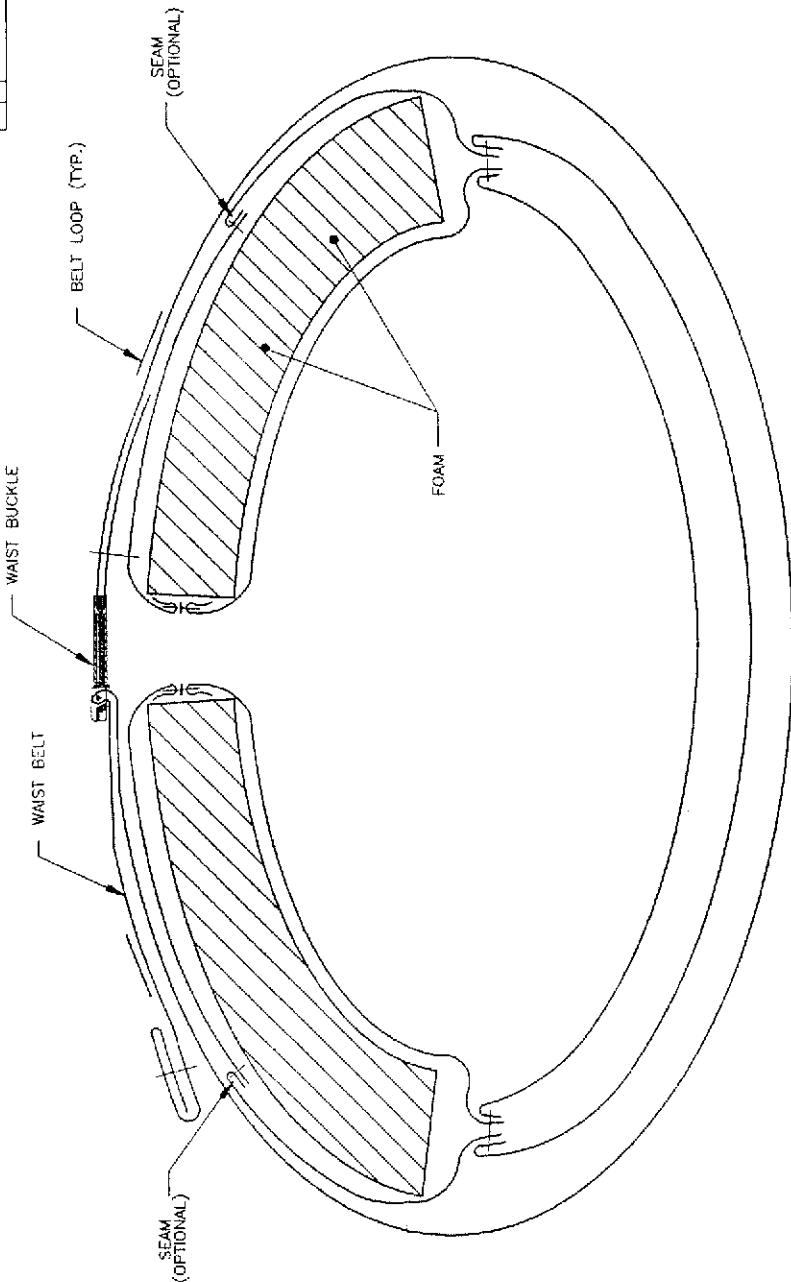

SECTION A-A  
REMOVED & EXPANDED

QUANTITY	ITEM NO.	DESCRIPTION	UNIT	QTY	PRICE	TOTAL
1	1	VEST	EA	1	37.463	37.463
1	2	WAIST BELT	EA	1	3.24	3.24
1	3	WAIST BUCKLE	EA	1	1.25	1.25
1	4	BELT LOOP	EA	1	0.15	0.15
1	5	SEAM	EA	1	0.15	0.15
1	6	FOAM	EA	1	0.15	0.15
1	7	STRAP	EA	1	0.15	0.15
1	8	BUCKLE	EA	1	0.15	0.15
1	9	SEAM	EA	1	0.15	0.15
1	10	SEAM	EA	1	0.15	0.15
1	11	SEAM	EA	1	0.15	0.15
1	12	SEAM	EA	1	0.15	0.15
1	13	SEAM	EA	1	0.15	0.15
1	14	SEAM	EA	1	0.15	0.15
1	15	SEAM	EA	1	0.15	0.15
1	16	SEAM	EA	1	0.15	0.15
1	17	SEAM	EA	1	0.15	0.15
1	18	SEAM	EA	1	0.15	0.15
1	19	SEAM	EA	1	0.15	0.15
1	20	SEAM	EA	1	0.15	0.15
1	21	SEAM	EA	1	0.15	0.15
1	22	SEAM	EA	1	0.15	0.15
1	23	SEAM	EA	1	0.15	0.15
1	24	SEAM	EA	1	0.15	0.15
1	25	SEAM	EA	1	0.15	0.15
1	26	SEAM	EA	1	0.15	0.15
1	27	SEAM	EA	1	0.15	0.15
1	28	SEAM	EA	1	0.15	0.15
1	29	SEAM	EA	1	0.15	0.15
1	30	SEAM	EA	1	0.15	0.15
1	31	SEAM	EA	1	0.15	0.15
1	32	SEAM	EA	1	0.15	0.15
1	33	SEAM	EA	1	0.15	0.15
1	34	SEAM	EA	1	0.15	0.15
1	35	SEAM	EA	1	0.15	0.15
1	36	SEAM	EA	1	0.15	0.15
1	37	SEAM	EA	1	0.15	0.15
1	38	SEAM	EA	1	0.15	0.15
1	39	SEAM	EA	1	0.15	0.15
1	40	SEAM	EA	1	0.15	0.15
1	41	SEAM	EA	1	0.15	0.15
1	42	SEAM	EA	1	0.15	0.15
1	43	SEAM	EA	1	0.15	0.15
1	44	SEAM	EA	1	0.15	0.15
1	45	SEAM	EA	1	0.15	0.15
1	46	SEAM	EA	1	0.15	0.15
1	47	SEAM	EA	1	0.15	0.15
1	48	SEAM	EA	1	0.15	0.15
1	49	SEAM	EA	1	0.15	0.15
1	50	SEAM	EA	1	0.15	0.15
1	51	SEAM	EA	1	0.15	0.15
1	52	SEAM	EA	1	0.15	0.15
1	53	SEAM	EA	1	0.15	0.15
1	54	SEAM	EA	1	0.15	0.15
1	55	SEAM	EA	1	0.15	0.15
1	56	SEAM	EA	1	0.15	0.15
1	57	SEAM	EA	1	0.15	0.15
1	58	SEAM	EA	1	0.15	0.15
1	59	SEAM	EA	1	0.15	0.15
1	60	SEAM	EA	1	0.15	0.15
1	61	SEAM	EA	1	0.15	0.15
1	62	SEAM	EA	1	0.15	0.15
1	63	SEAM	EA	1	0.15	0.15
1	64	SEAM	EA	1	0.15	0.15
1	65	SEAM	EA	1	0.15	0.15
1	66	SEAM	EA	1	0.15	0.15
1	67	SEAM	EA	1	0.15	0.15
1	68	SEAM	EA	1	0.15	0.15
1	69	SEAM	EA	1	0.15	0.15
1	70	SEAM	EA	1	0.15	0.15
1	71	SEAM	EA	1	0.15	0.15
1	72	SEAM	EA	1	0.15	0.15
1	73	SEAM	EA	1	0.15	0.15
1	74	SEAM	EA	1	0.15	0.15
1	75	SEAM	EA	1	0.15	0.15
1	76	SEAM	EA	1	0.15	0.15
1	77	SEAM	EA	1	0.15	0.15
1	78	SEAM	EA	1	0.15	0.15
1	79	SEAM	EA	1	0.15	0.15
1	80	SEAM	EA	1	0.15	0.15
1	81	SEAM	EA	1	0.15	0.15
1	82	SEAM	EA	1	0.15	0.15
1	83	SEAM	EA	1	0.15	0.15
1	84	SEAM	EA	1	0.15	0.15
1	85	SEAM	EA	1	0.15	0.15
1	86	SEAM	EA	1	0.15	0.15
1	87	SEAM	EA	1	0.15	0.15
1	88	SEAM	EA	1	0.15	0.15
1	89	SEAM	EA	1	0.15	0.15
1	90	SEAM	EA	1	0.15	0.15
1	91	SEAM	EA	1	0.15	0.15
1	92	SEAM	EA	1	0.15	0.15
1	93	SEAM	EA	1	0.15	0.15
1	94	SEAM	EA	1	0.15	0.15
1	95	SEAM	EA	1	0.15	0.15
1	96	SEAM	EA	1	0.15	0.15
1	97	SEAM	EA	1	0.15	0.15
1	98	SEAM	EA	1	0.15	0.15
1	99	SEAM	EA	1	0.15	0.15
1	100	SEAM	EA	1	0.15	0.15

MUSTANG SURVIVAL CORP.  
 GENERAL ILLUSTRATION NUMBER:  
 BB30, BB31, BB32, BB33, BB34, BB35, BB36, BB37, BB38, BB39, BB40, BB41, BB42, BB43, BB44, BB45, BB46, BB47, BB48, BB49, BB50, BB51, BB52, BB53, BB54, BB55, BB56, BB57, BB58, BB59, BB60, BB61, BB62, BB63, BB64, BB65, BB66, BB67, BB68, BB69, BB70, BB71, BB72, BB73, BB74, BB75, BB76, BB77, BB78, BB79, BB80, BB81, BB82, BB83, BB84, BB85, BB86, BB87, BB88, BB89, BB90, BB91, BB92, BB93, BB94, BB95, BB96, BB97, BB98, BB99, BB100, BB101, BB102, BB103, BB104, BB105, BB106, BB107, BB108, BB109, BB110, BB111, BB112, BB113, BB114, BB115, BB116, BB117, BB118, BB119, BB120, BB121, BB122, BB123, BB124, BB125, BB126, BB127, BB128, BB129, BB130, BB131, BB132, BB133, BB134, BB135, BB136, BB137, BB138, BB139, BB140, BB141, BB142, BB143, BB144, BB145, BB146, BB147, BB148, BB149, BB150, BB151, BB152, BB153, BB154, BB155, BB156, BB157, BB158, BB159, BB160, BB161, BB162, BB163, BB164, BB165, BB166, BB167, BB168, BB169, BB170, BB171, BB172, BB173, BB174, BB175, BB176, BB177, BB178, BB179, BB180, BB181, BB182, BB183, BB184, BB185, BB186, BB187, BB188, BB189, BB190, BB191, BB192, BB193, BB194, BB195, BB196, BB197, BB198, BB199, BB200, BB201, BB202, BB203, BB204, BB205, BB206, BB207, BB208, BB209, BB210, BB211, BB212, BB213, BB214, BB215, BB216, BB217, BB218, BB219, BB220, BB221, BB222, BB223, BB224, BB225, BB226, BB227, BB228, BB229, BB230, BB231, BB232, BB233, BB234, BB235, BB236, BB237, BB238, BB239, BB240, BB241, BB242, BB243, BB244, BB245, BB246, BB247, BB248, BB249, BB250, BB251, BB252, BB253, BB254, BB255, BB256, BB257, BB258, BB259, BB260, BB261, BB262, BB263, BB264, BB265, BB266, BB267, BB268, BB269, BB270, BB271, BB272, BB273, BB274, BB275, BB276, BB277, BB278, BB279, BB280, BB281, BB282, BB283, BB284, BB285, BB286, BB287, BB288, BB289, BB290, BB291, BB292, BB293, BB294, BB295, BB296, BB297, BB298, BB299, BB300, BB301, BB302, BB303, BB304, BB305, BB306, BB307, BB308, BB309, BB310, BB311, BB312, BB313, BB314, BB315, BB316, BB317, BB318, BB319, BB320, BB321, BB322, BB323, BB324, BB325, BB326, BB327, BB328, BB329, BB330, BB331, BB332, BB333, BB334, BB335, BB336, BB337, BB338, BB339, BB340, BB341, BB342, BB343, BB344, BB345, BB346, BB347, BB348, BB349, BB350, BB351, BB352, BB353, BB354, BB355, BB356, BB357, BB358, BB359, BB360,





# B830, MV1203, MV1233 – VEST, BUOYANCY AID FOAM – FRONT

## LINEAR TOLERANCES:

0 – 10" = +/- 1/4"  
 10 – 15" = +/- 3/8"  
 15 – 25" = +/- 1/2"  
 25" and OVER = +/- 3/4"  
 Thickness: +/- 10%

## DIMENSIONS:

Size	# of Foam Layers per side @ 1/4" or 5/16" each
INFANT	5

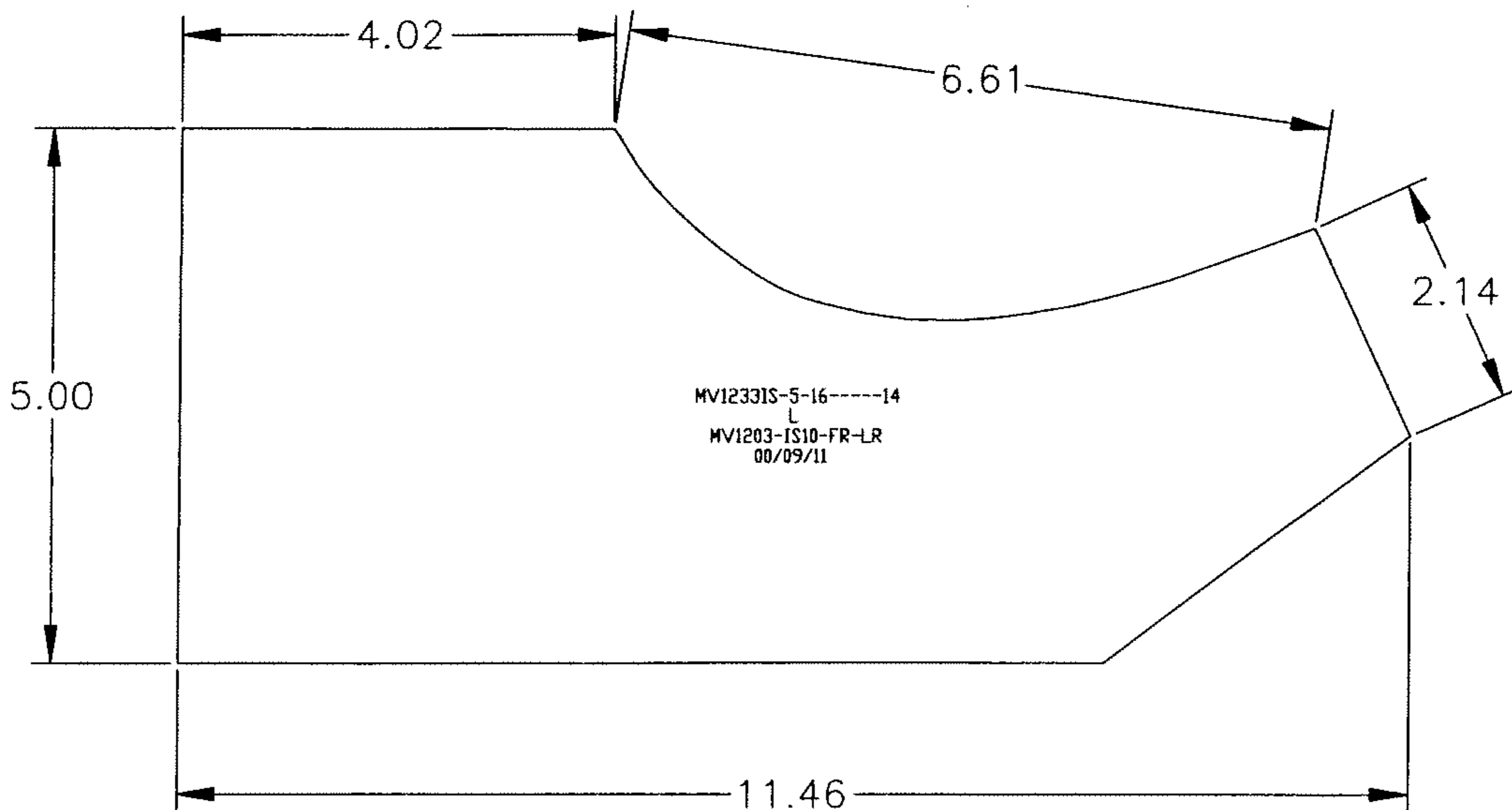

# B830, MV1203, MV1233 – VEST, BUOYANCY AID FOAM – BACK

## LINEAR TOLERANCES:

0 – 10" = +/- 1/4"  
 10 – 15" = +/- 3/8"  
 15 – 25" = +/- 1/2"  
 25" and OVER = +/- 3/4"  
 Thickness: +/- 10%

## DIMENSIONS:

Size	# of Foam Layers @ 1/4" or 5/16" each
INFANT	4

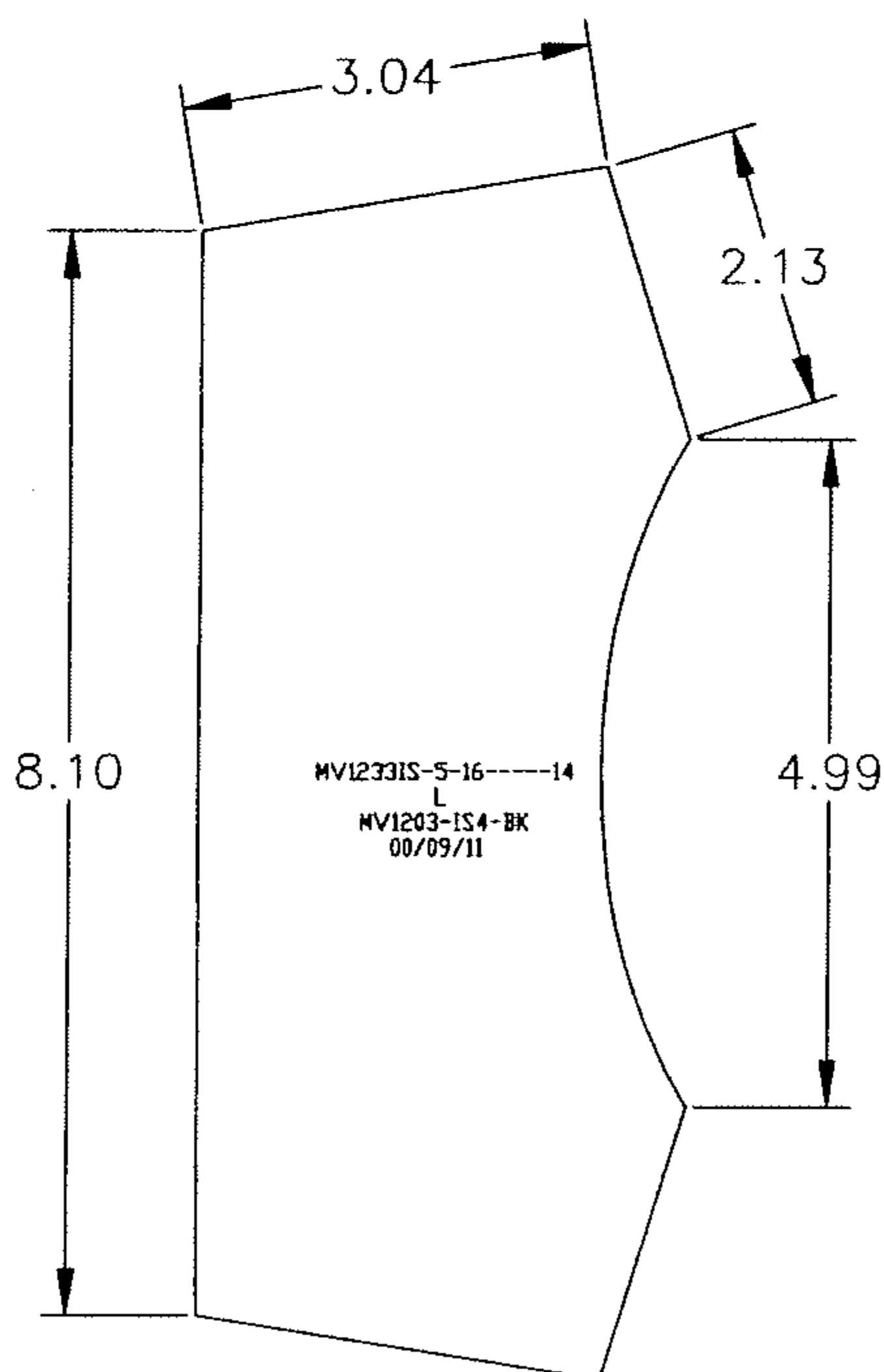

# B830, MV1203, MV1233 – VEST, BUOYANCY AID FOAM – COLLAR CENTRE

## LINEAR TOLERANCES:

0 – 10" = +/- 1/4"  
 10 – 15" = +/- 3/8"  
 15 – 25" = +/- 1/2"  
 25" and OVER = +/- 3/4"  
 Thickness: +/- 10%

## DIMENSIONS:

Size	# of Foam Layers @ 1/4" or 5/16" each
INFANT	4

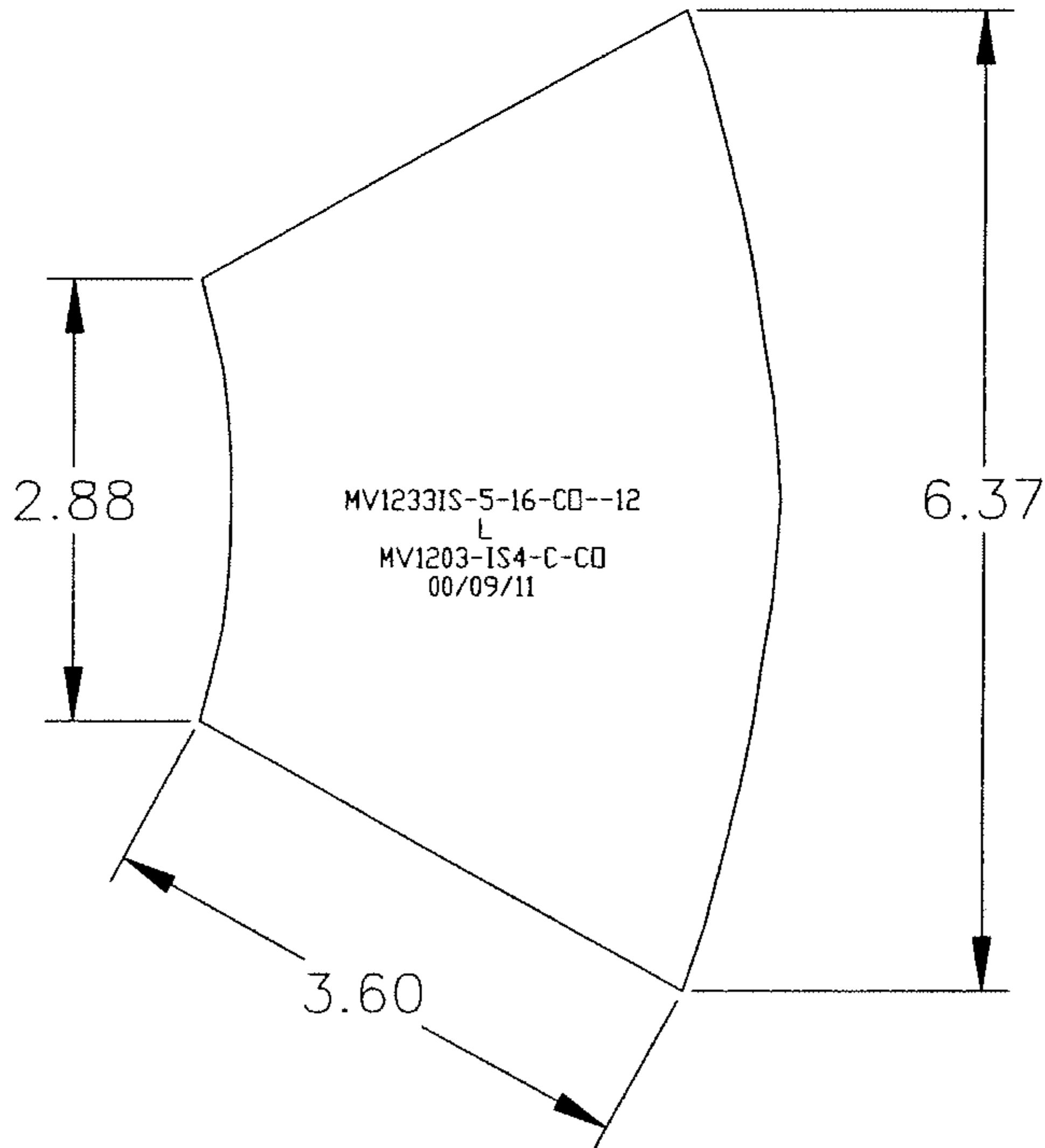

# B830, MV1203, MV1233 – VEST, BUOYANCY AID FOAM – COLLAR SIDES

## LINEAR TOLERANCES:

0 – 10" = +/- 1/4"  
 10 – 15" = +/- 3/8"  
 15 – 25" = +/- 1/2"  
 25" and OVER = +/- 3/4"  
 Thickness: +/- 10%

## DIMENSIONS:

Size	# of Foam Layers per side @ 1/4" or 5/16" each
INFANT	4

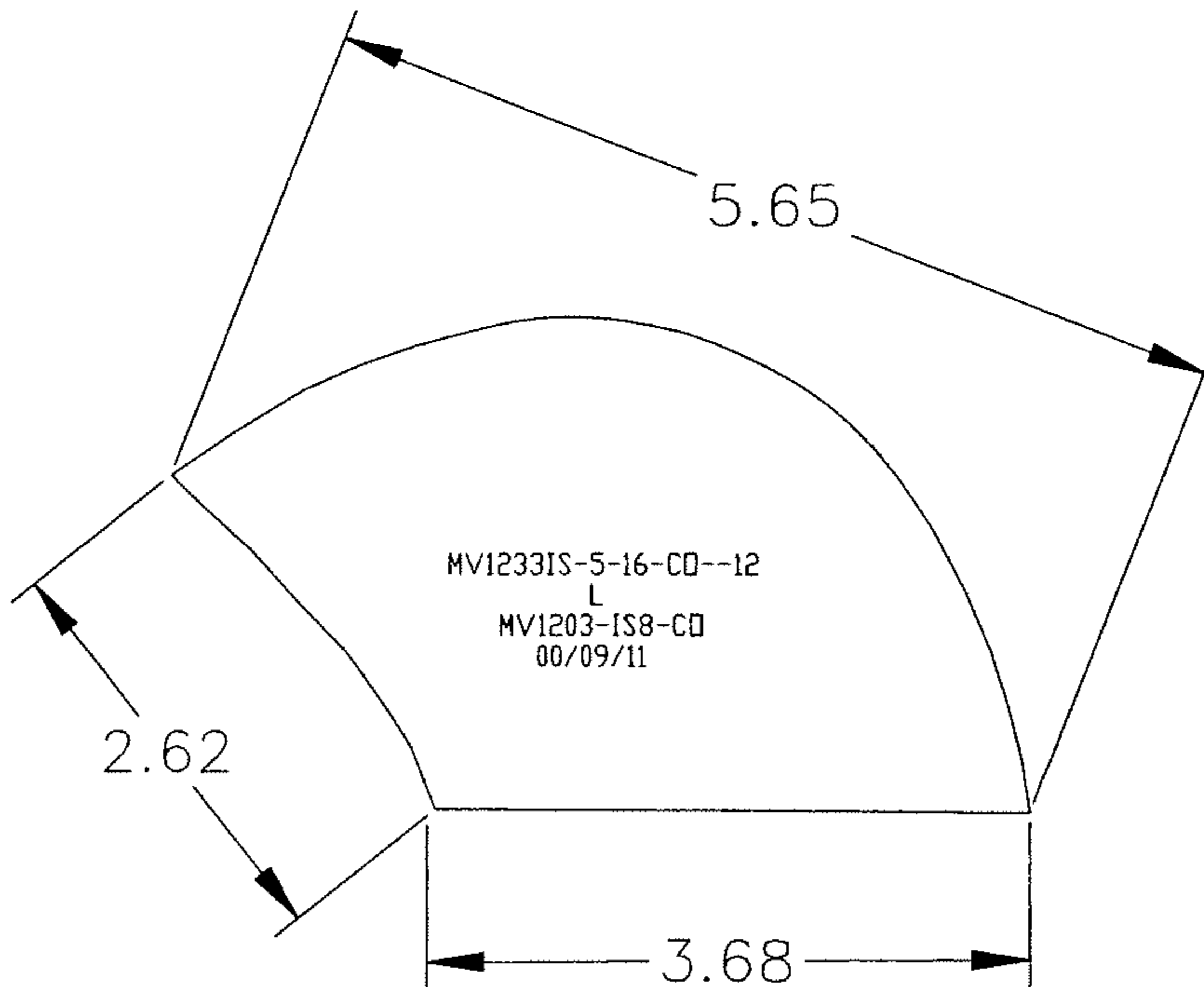

# B831, MV1205, MV1235, MV1245 – VEST, BUOYANCY AID FOAM – FRONT

## LINEAR TOLERANCES:

0 – 10" = +/- 1/4"

10 – 15" = +/- 3/8"

15 – 25" = +/- 1/2"

25" and OVER = +/- 3/4"

Thickness: +/- 10%

## DIMENSIONS:

Size	# of Foam Layers per side @ 1/4" or 5/16" each
CHILD	5

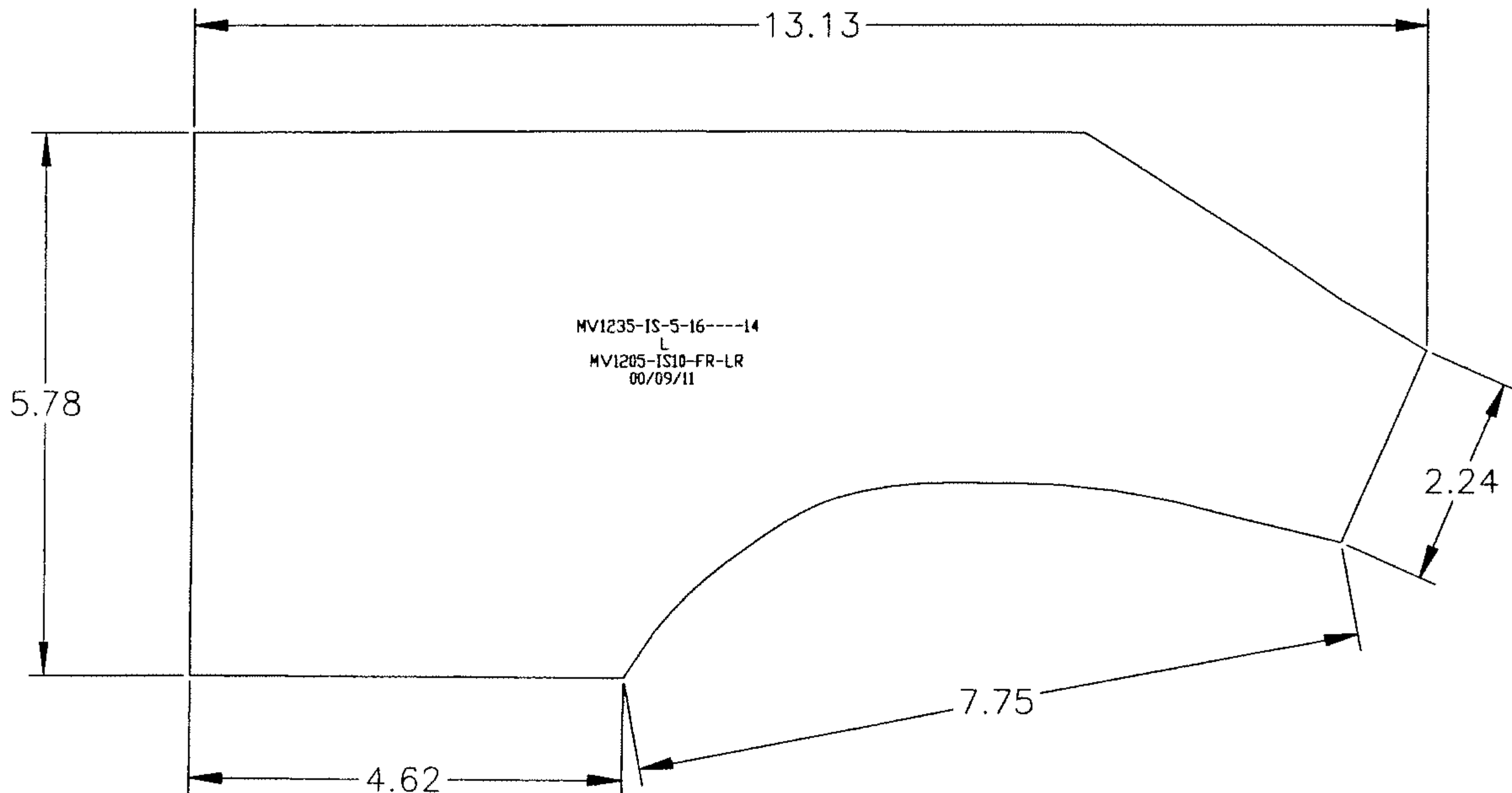

# B831, MV1205, MV1235, MV1245 – VEST, BUOYANCY AID FOAM – BACK

## LINEAR TOLERANCES:

- 0 – 10" = +/- 1/4"
- 10 – 15" = +/- 3/8"
- 15 – 25" = +/- 1/2"
- 25" and OVER = +/- 3/4"
- Thickness: +/- 10%

## DIMENSIONS:

Size	# of Foam Layers @ 1/4" or 5/16" each
CHILD	4

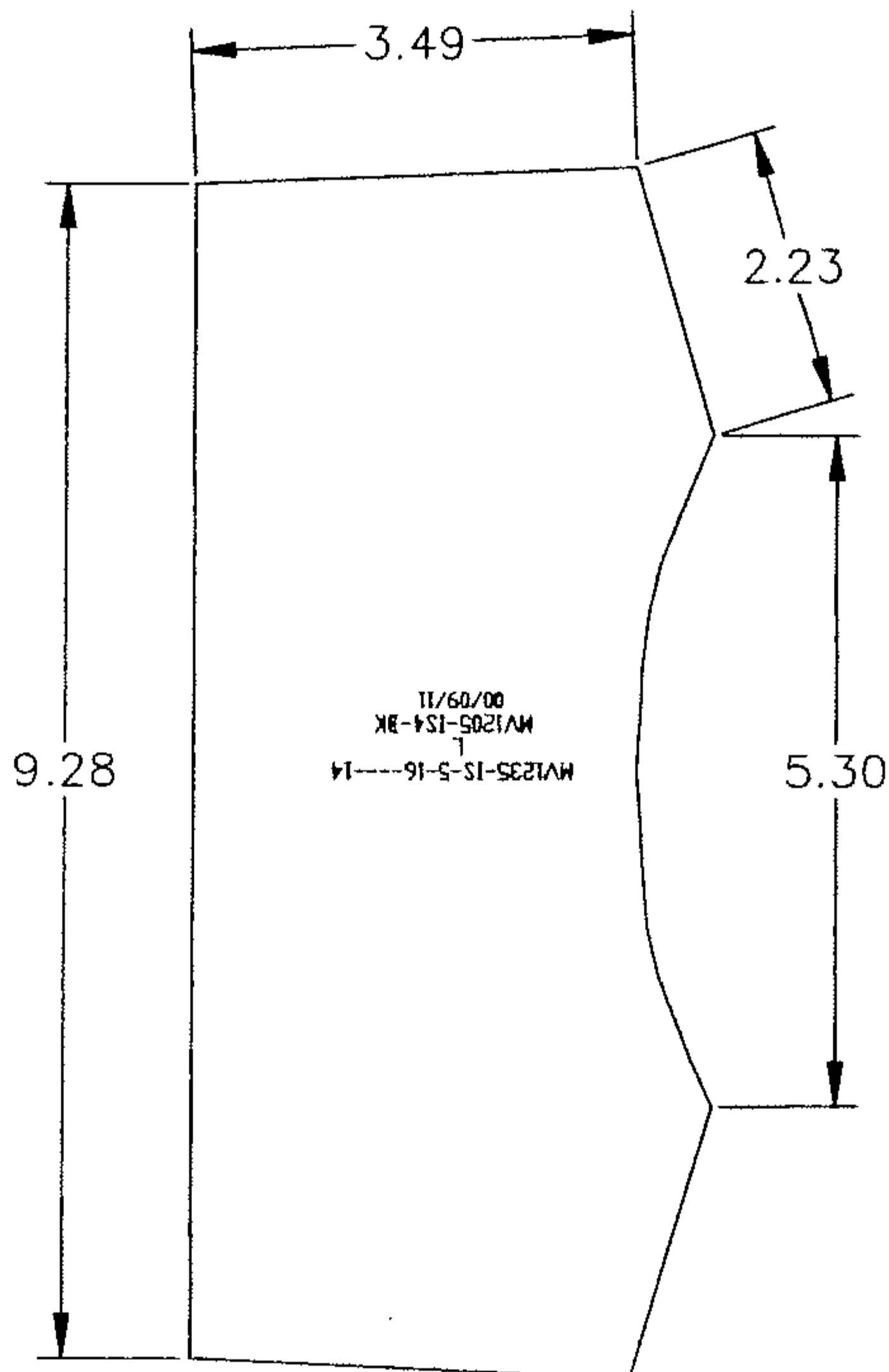

# B831, MV1205, MV1235, MV1245 – VEST, BUOYANCY AID FOAM – COLLAR CENTRE

## LINEAR TOLERANCES:

- 0 – 10" = +/- 1/4"
- 10 – 15" = +/- 3/8"
- 15 – 25" = +/- 1/2"
- 25" and OVER = +/- 3/4"
- Thickness: +/- 10%

## DIMENSIONS:

Size	# of Foam Layers @ 1/4" or 5/16" each
CHILD	4

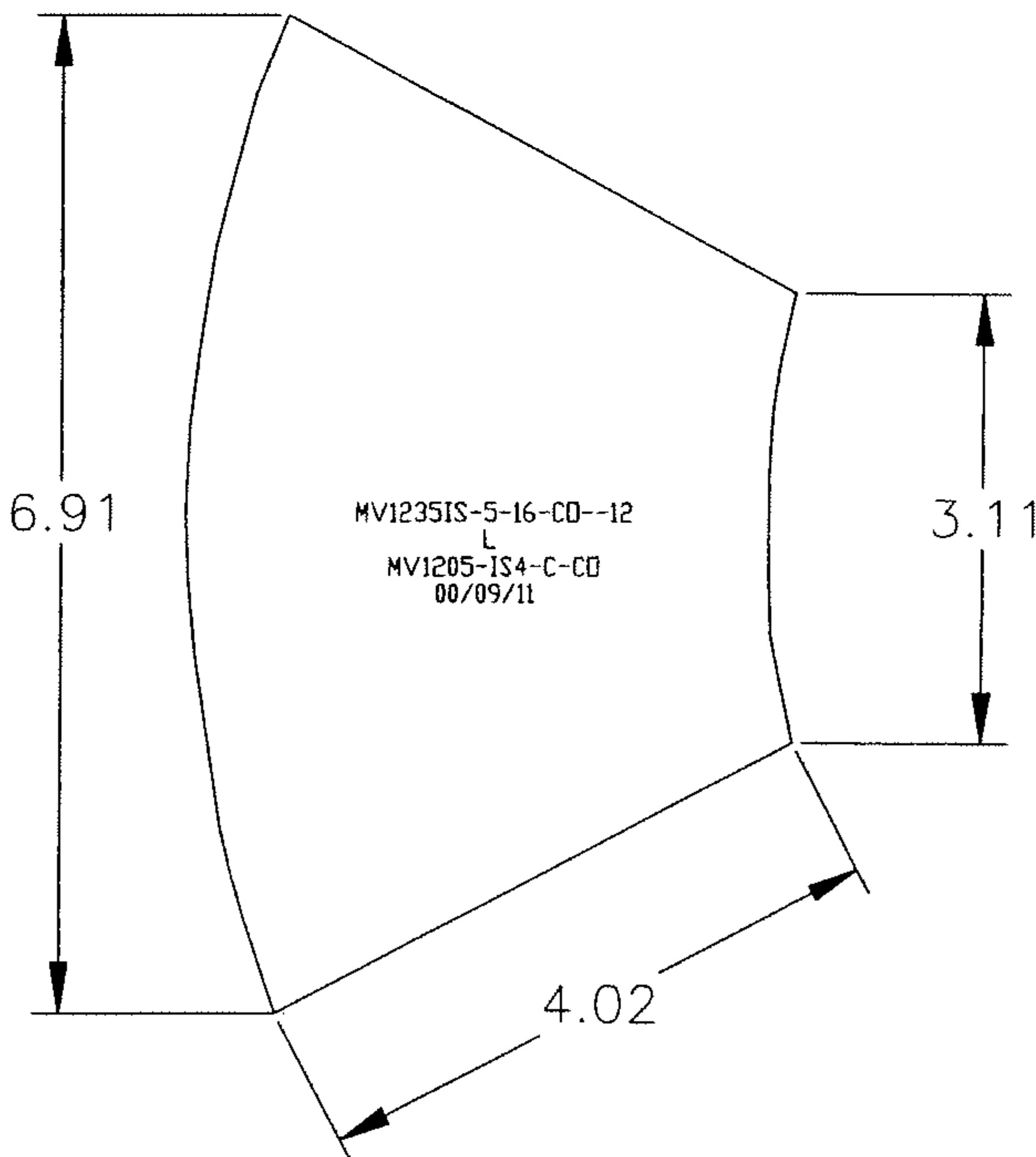

# B831, MV1205, MV1235, MV1245 – VEST, BUOYANCY AID FOAM – COLLAR SIDES

## LINEAR TOLERANCES:

0 – 10" = +/- 1/4"

10 – 15" = +/- 3/8"

15 – 25" = +/- 1/2"

25" and OVER = +/- 3/4"

Thickness: +/- 10%

## DIMENSIONS:

Size	# of Foam Layers per side @ 1/4" or 5/16" each
CHILD	4

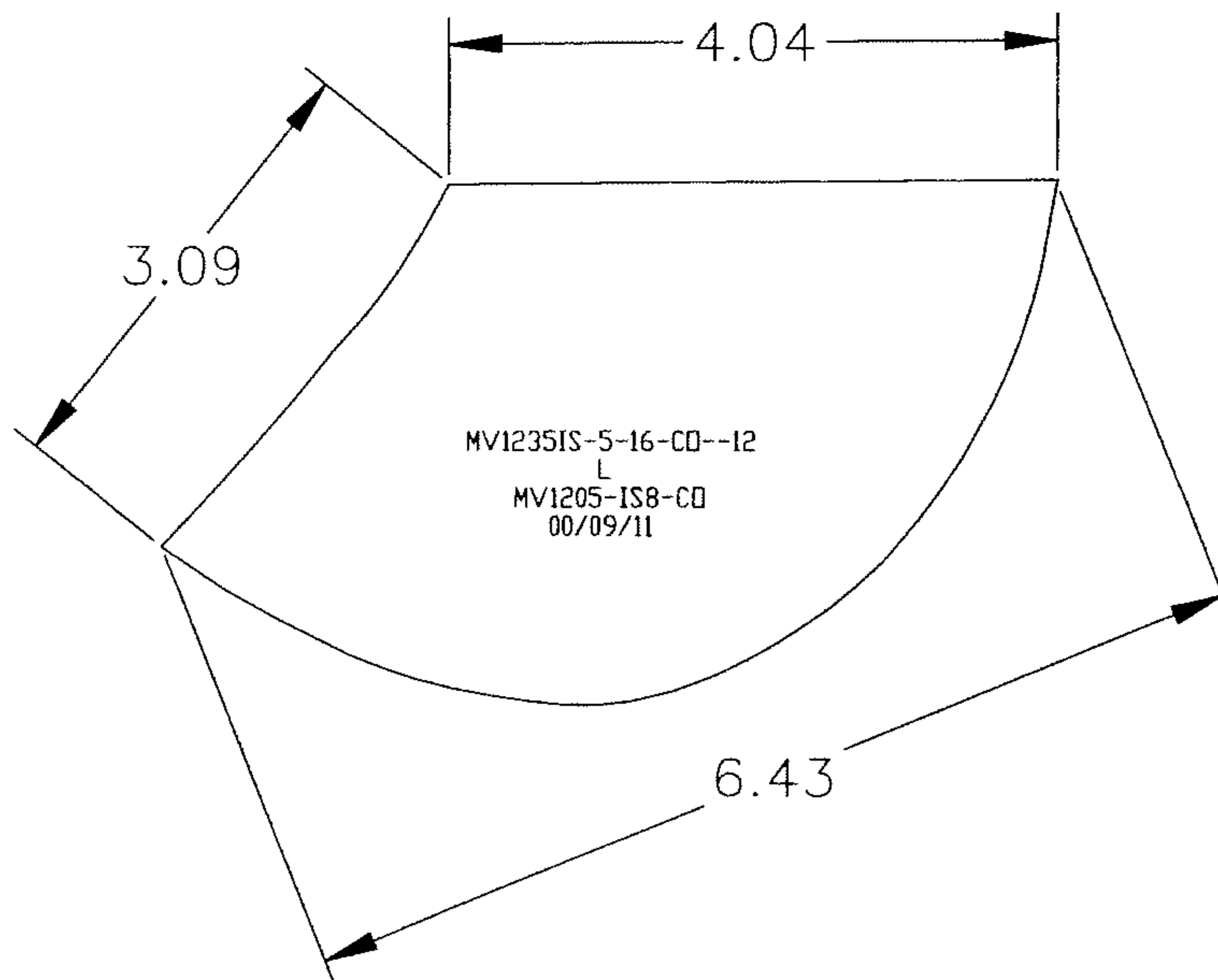



# B832, MV1207, MV1237, MV1247 – VEST, BUOYANCY AID FOAM – FRONT

## LINEAR TOLERANCES:

- 0 – 10" = +/- 1/4"
- 10 – 15" = +/- 3/8"
- 15 – 25" = +/- 1/2"
- 25" and OVER = +/- 3/4"

## DIMENSIONS:

Size	# of Foam Layers per side @ 1/4" or 5/16" each
YOUTH	5

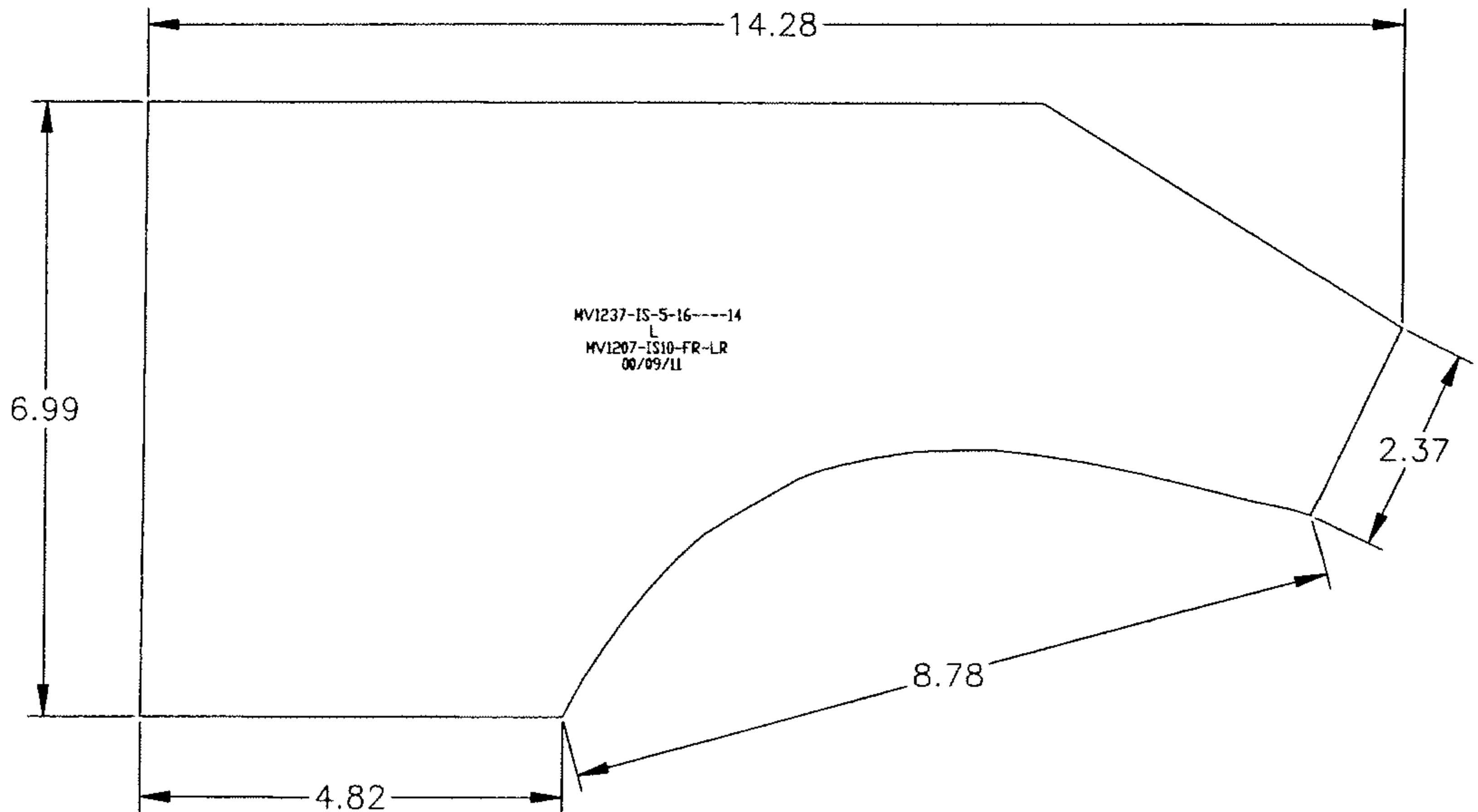

File MQ1617 Vol. 3 Sec. 2 File 16 and Section Issue: 2009-05-26

# B832, MV1207, MV1237, MV1247 – VEST, BUOYANCY AID FOAM – BACK

## LINEAR TOLERANCES:

- 0 – 10" = +/- 1/4"
- 10 – 15" = +/- 3/8"
- 15 – 25" = +/- 1/2"
- 25" and OVER = +/- 3/4"

## DIMENSIONS:

Size	# of Foam Layers @ 1/4" or 5/16" each
YOUTH	4

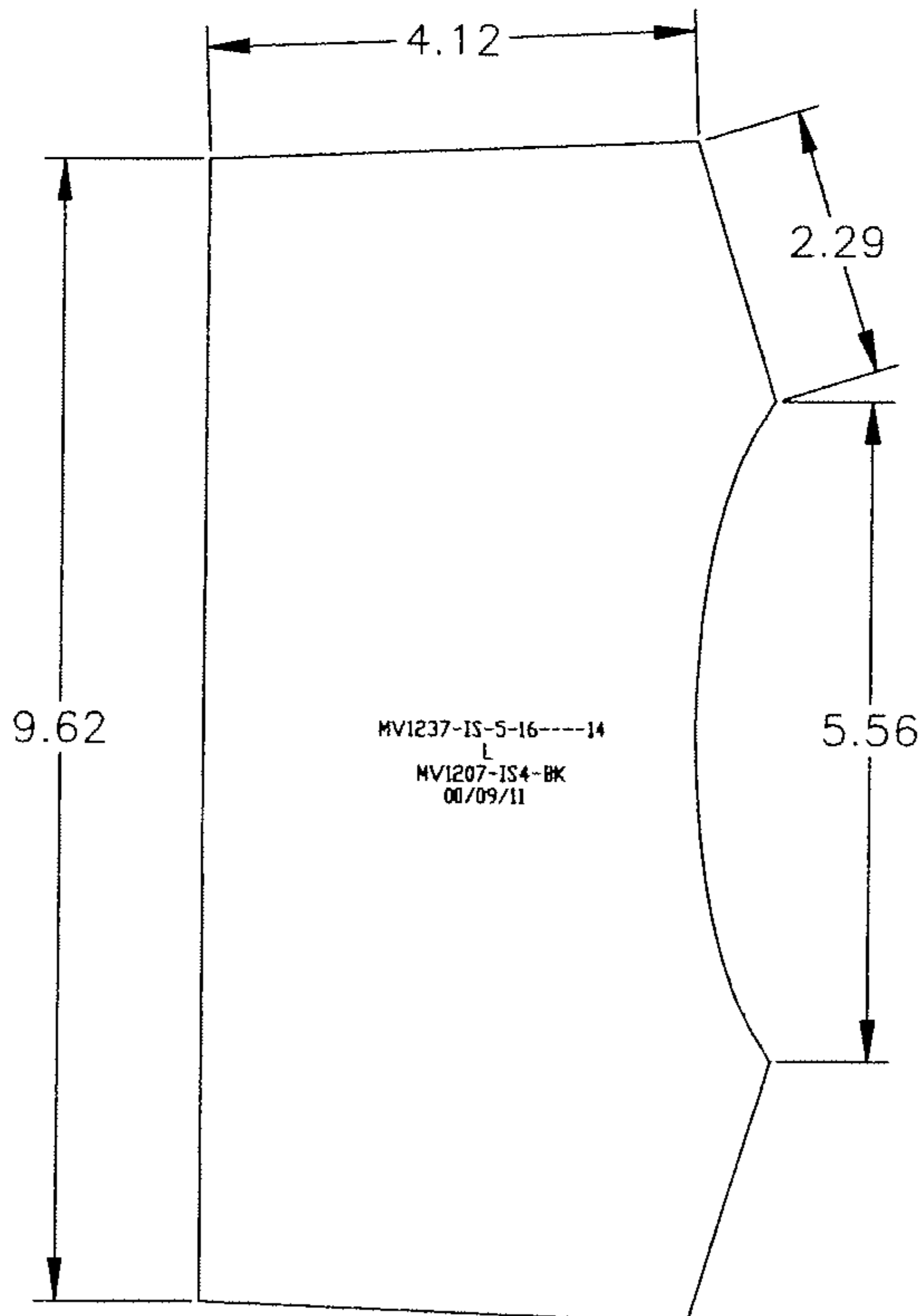

File MQ1617

# B832, MV1207, MV1237, MV1247 – VEST, BUOYANCY AID FOAM – COLLAR CENTRE

Issue 007-05-26

## LINEAR TOLERANCES:

0 – 10" = +/- 1/4"  
10 – 15" = +/- 3/8"  
15 – 25" = +/- 1/2"  
25" and OVER = +/- 3/4"  
Thickness: +/- 10%

## DIMENSIONS:

Size	# of Foam Layers @ 1/4" or 5/16" each
YOUTH	4

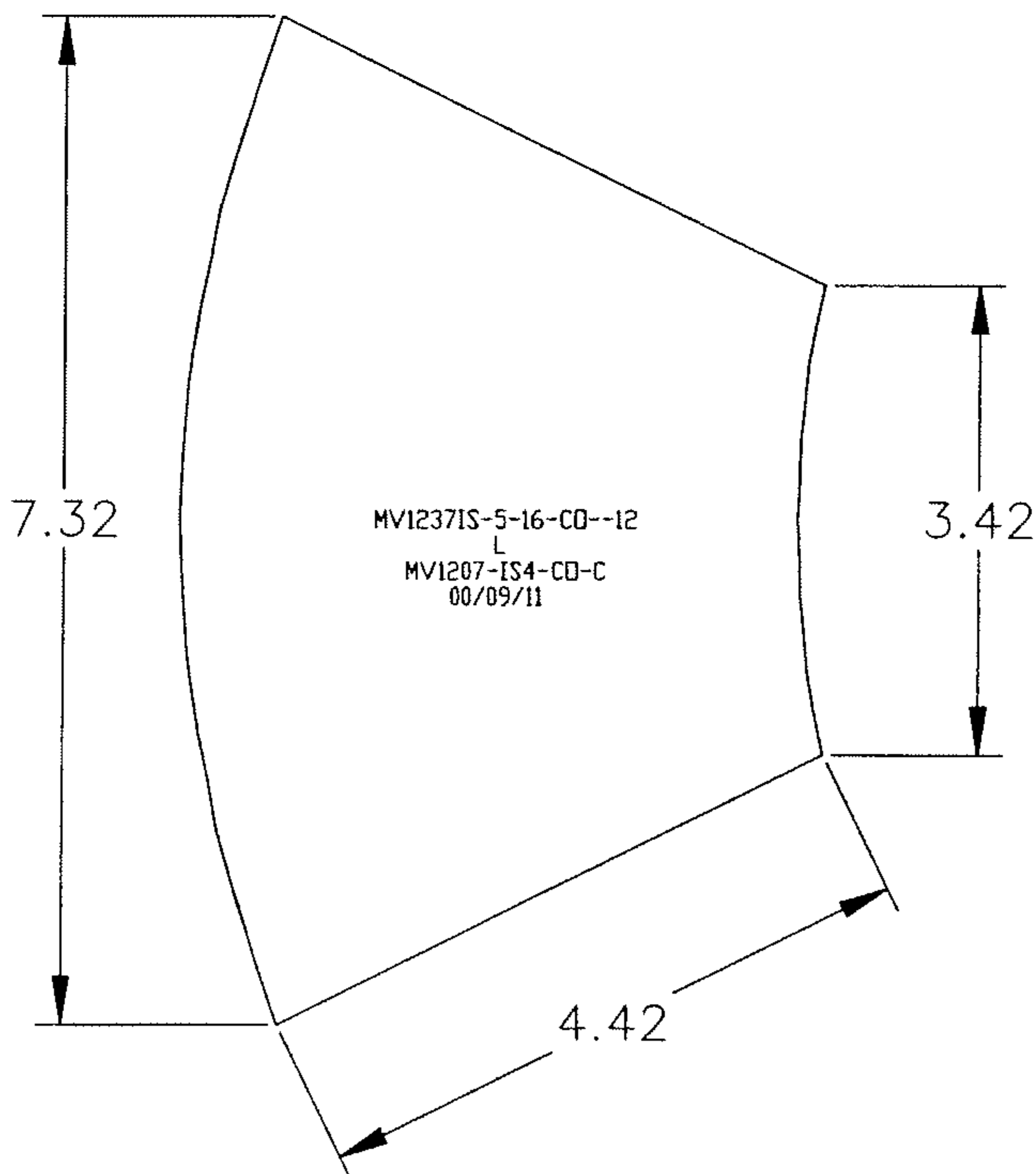

# B832, MV1207, MV1237, MV1247 – VEST, BUOYANCY AID FOAM – COLLAR SIDES

## LINEAR TOLERANCES:

0 – 10" = +/- 1/4"  
 10 – 15" = +/- 3/8"  
 15 – 25" = +/- 1/2"  
 25" and OVER = +/- 3/4"  
 Thickness: +/- 10%

## DIMENSIONS:

Size	# of Foam Layers per side @ 1/4" or 5/16" each
YOUTH	4

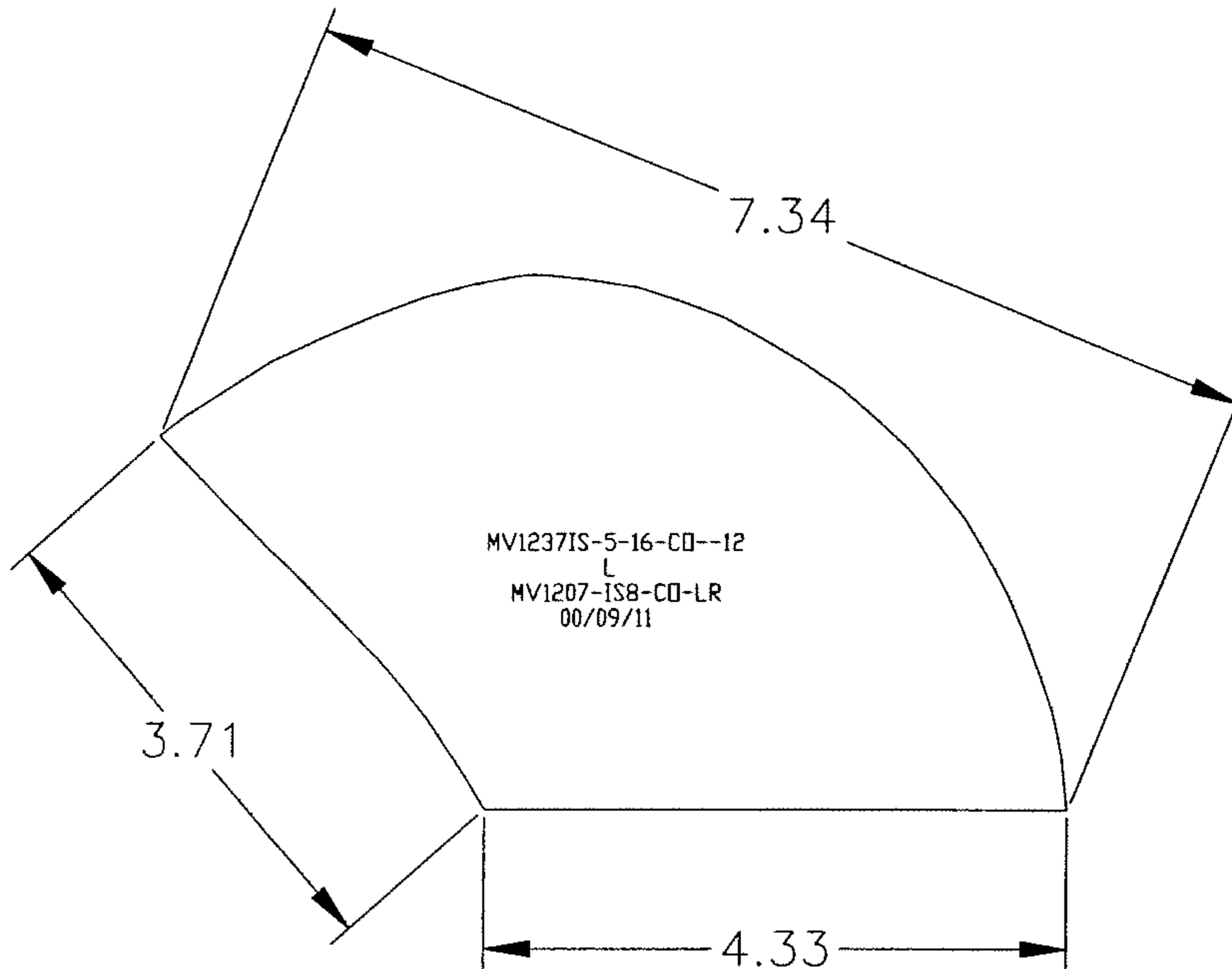

# SHELL PATTERN

## B830, B831, B832

Drawings not to scale

Dimensions in inches

### FRONT

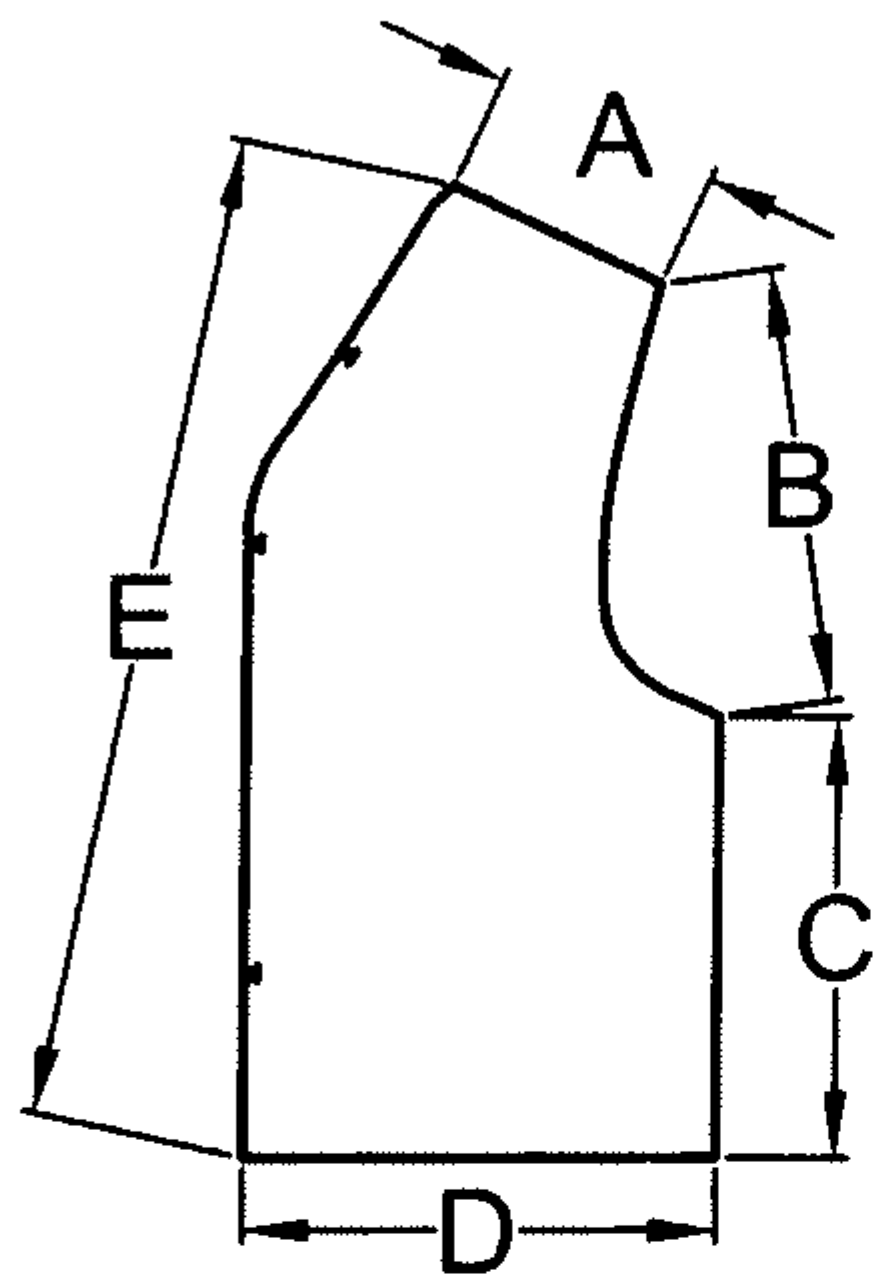

No. Required: 2 per unit (L&R)

### COLLAR

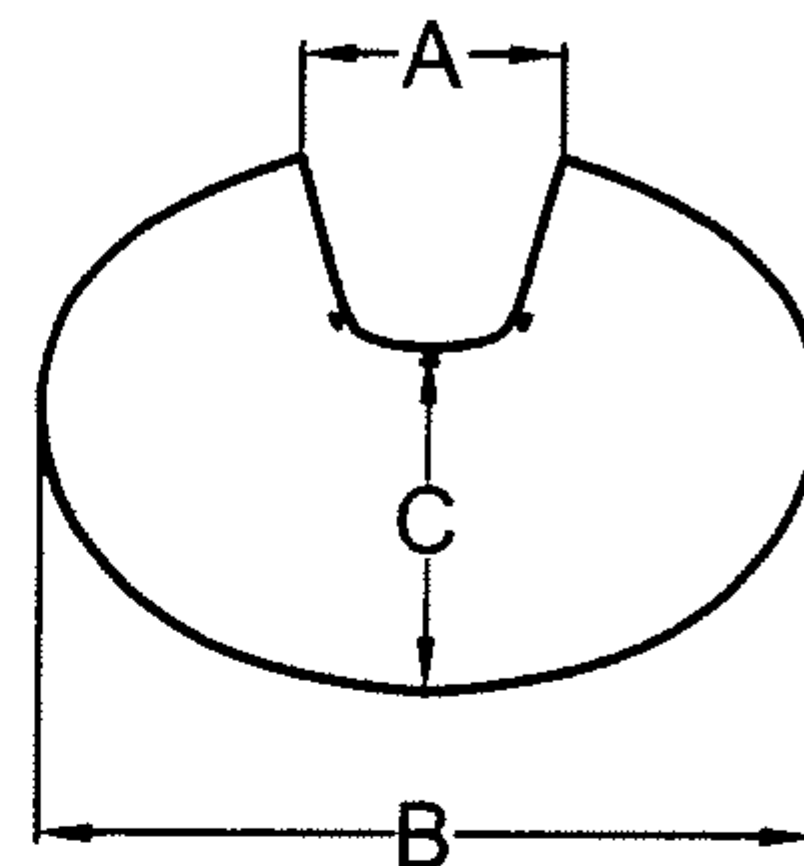

No. Required: 2 per unit (TOP & BOTTOM)

STYLE	A	B	C
B830	4.86	14.45	6.38
B831	5.67	15.51	6.88
B832	6.59	16.57	7.34

STYLE	A	B	C	D	E
B830	4.27	6.73	7.78	8.00	16.75
B831	4.27	8.10	8.22	8.81	18.48
B832	4.27	9.26	8.77	10.52	19.80

### BACK

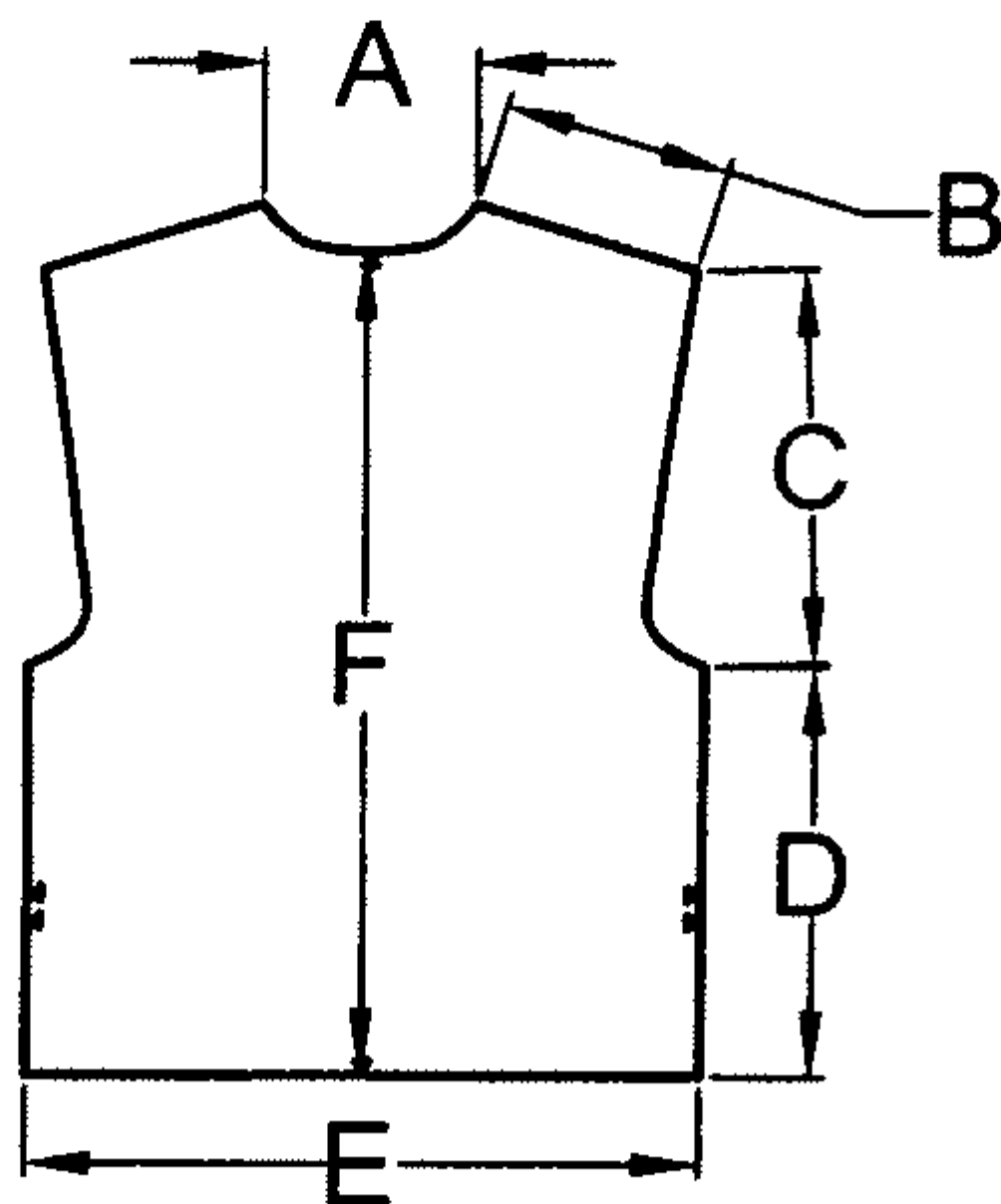

No. Required: 1 per unit

STYLE	A	B	C	D	E	F
B830	3.97	4.30	7.42	7.70	12.63	15.45
B831	4.20	4.28	8.78	8.23	15.58	17.23
B832	4.50	4.30	9.74	8.77	18.07	18.55

Drawings not to scale  
 Dimensions in inches

BACK

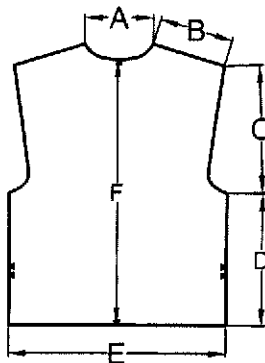

No. Required: 1 per unit

STYLE	A	B	C	D	E	F
MV1203	3.97	4.30	7.42	7.70	12.63	15.45
MV1205	4.20	4.28	8.79	8.22	15.58	17.23
MV1207	4.50	4.30	9.74	8.77	18.07	18.55

COLLAR

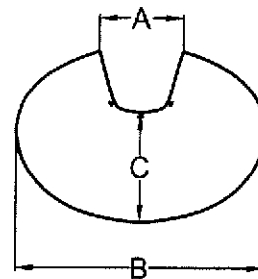

No. Required: 2 per unit (TOP & BOTTOM)

STYLE	A	B	C
MV1203	4.86	14.45	6.38
MV1205	5.67	15.51	6.88
MV1207	6.59	16.57	7.34

FRONT A

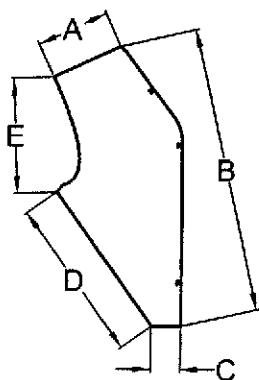

No. Required: 2 per unit (L&R)

STYLE	A	B	C	D	E
MV1203	4.27	16.75	1.72	9.60	6.73
MV1205	4.27	18.48	2.40	10.26	7.85
MV1207	4.27	19.80	3.13	10.61	9.06

FRONT B

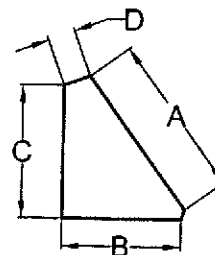

No. Required: 2 per unit (L&R)

STYLE	A	B	C	D
MV1203	9.58	6.91	7.78	1.60
MV1205	10.06	7.10	8.22	1.65
MV1207	10.60	8.00	8.77	2.12

**SHELL PATTERN**  
 MV1233, 1235, 1237

Drawings not to scale  
 Dimensions in inches

**BACK**

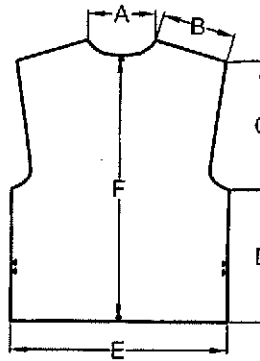

No. Required: 1 per unit

STYLE	A	B	C	D	E	F
MV1233	3.97	4.30	7.42	7.70	12.63	15.45
MV1235	4.20	4.28	8.78	8.23	15.58	17.23
MV1237	4.50	4.30	9.74	8.77	18.07	18.55

**FRONT**

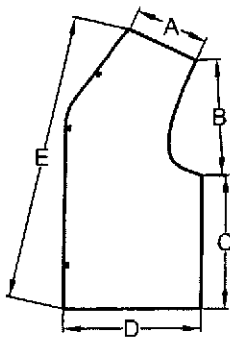

No. Required: 2 per unit (L&R)

**COLLAR**

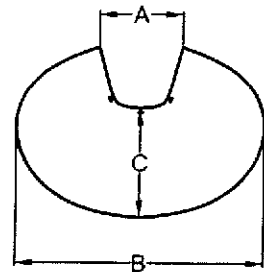

No. Required: 2 per unit (TOP & BTM)

STYLE	A	B	C	D	E
MV1233	4.27	6.73	7.78	8.00	16.75
MV1235	4.27	8.10	8.22	8.81	18.48
MV1237	4.27	9.26	8.77	10.52	19.80

STYLE	A	B	C
MV1233	4.86	14.45	6.38
MV1235	5.67	15.51	6.88
MV1237	6.59	16.55	7.34

# MV1245

## BACK

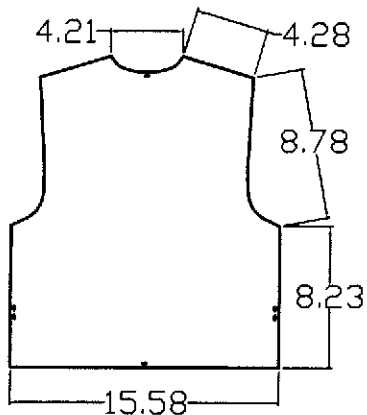

No. Required: 1 per unit

## FRONT

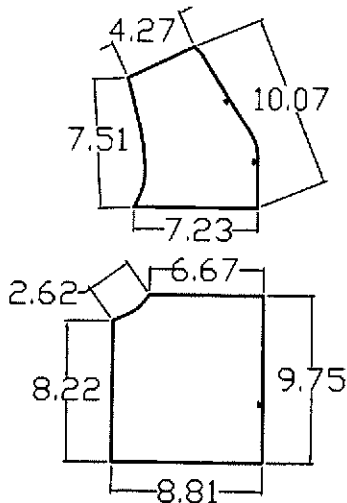

No. Required: 2 per unit (L & R)

## COLLAR

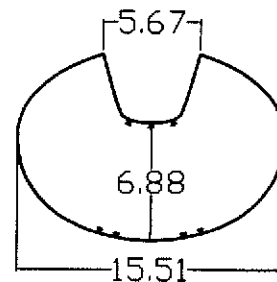

No. Required: 2 per unit  
(TOP & BOTTOM)

# MV1247

## BACK

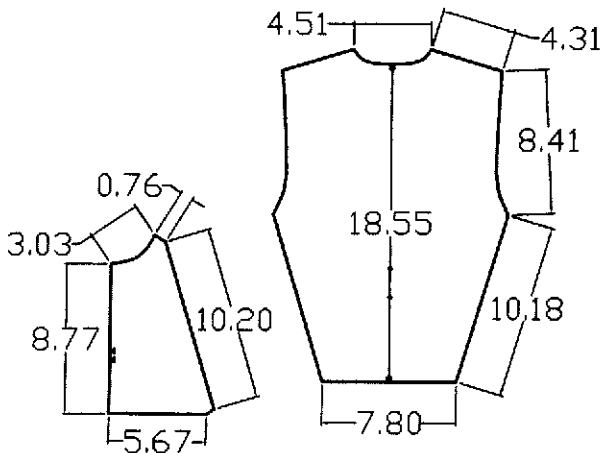

No. Required: 1 per unit

## FRONT

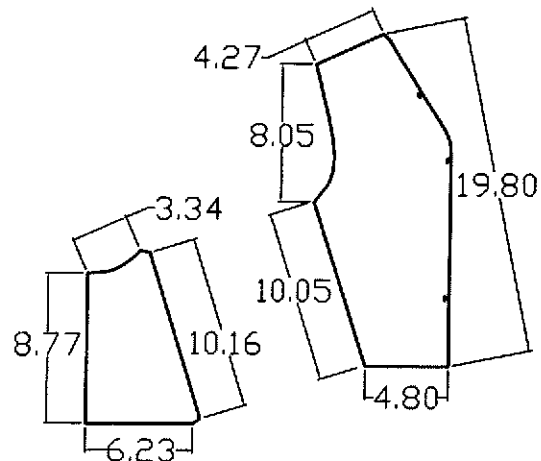

No. Required: 2 per unit (L & R)

## COLLAR

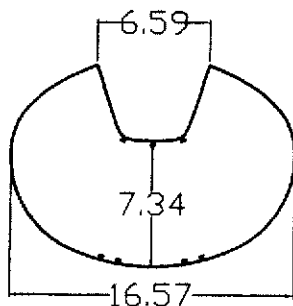

No. Required: 2 per unit  
(TOP & BOTTOM)



**MV1203, 1205, 1207**  
**1233, 1235, 1237**  
**1245, 1247**

Drawings not to scale  
 Dimensions in inches

**FRONT**

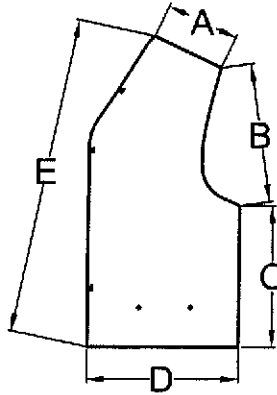

No. Required: 2 per unit (L&R)

STYLE	A	B	C	D	E
B830, MV1203, 1233	4.27	6.73	7.78	8.00	16.75
B831, MV1205, 1235, 1245	4.27	8.10	8.22	8.81	18.48
B832, MV1207, 1237, 1247	4.27	9.26	8.77	10.52	19.80

**BACK**

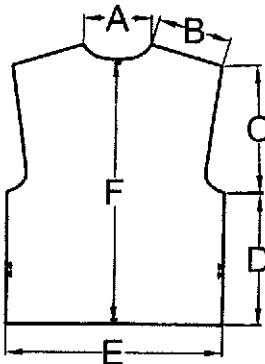

No. Required: 1 per unit

STYLE	A	B	C	D	E	F
B830, MV1203, 1233	3.97	4.30	7.42	7.70	12.63	15.45
B831, MV1205, 1235, 1245	4.20	4.28	8.78	8.23	15.58	17.23
B832, MV1207, 1237, 1247	4.50	4.30	9.74	8.77	18.07	18.55