

SIMPLIHOME®

Fallon / Jovie / Lainey

TV Media Stand

MODEL # AXCFAL-16-NL

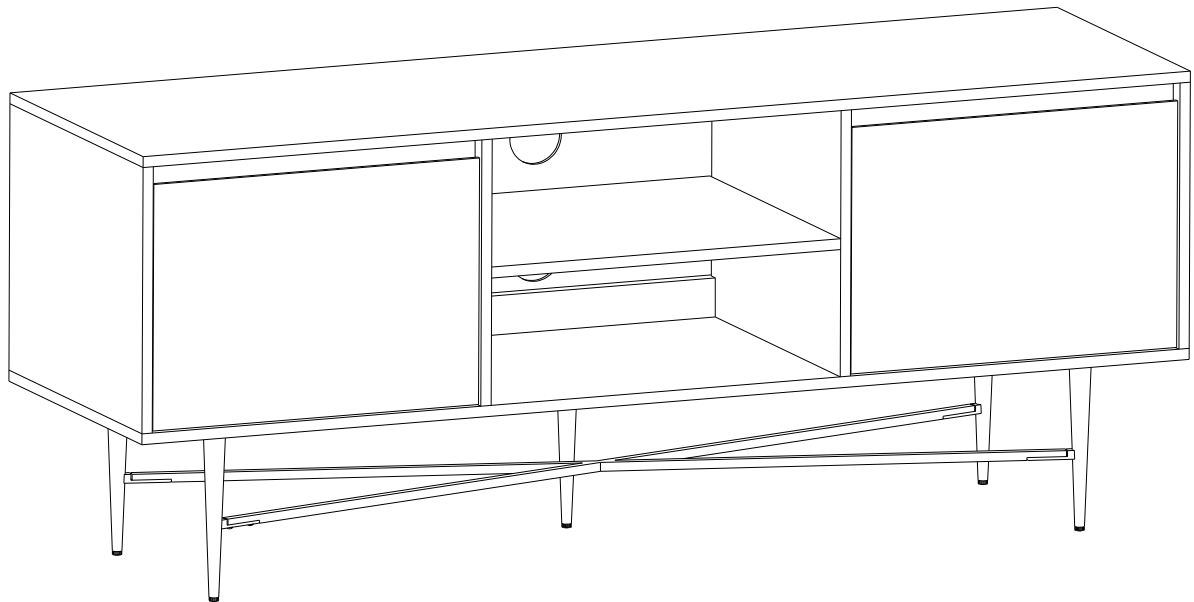

SIMPLIHOME®

Great quality is a right.

Thank you for shopping with Simpli Home,
America's top brand for high-value furniture.



It's time to register your product warranty.

It's quick and easy. And you'll be happy you did.



- ✓ Activate your **1-year** warranty
- ✓ Automatic entry to win a **\$500** gift certificate
- ✓ Earn instant rewards and **save**

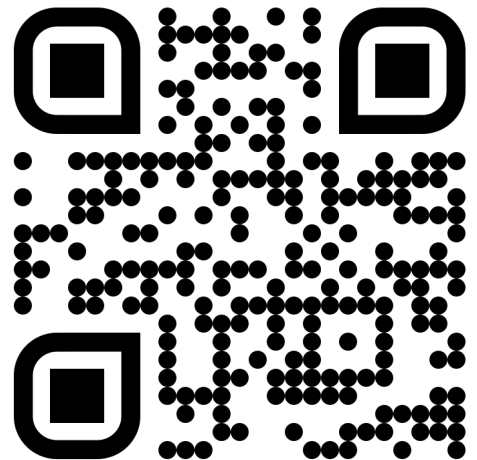

simpli-home.com/product-registration

SIMPLIHOME®

Review your product and collect rewards!

Thank you for your purchase! We hope you enjoy it. We'd love your feedback. Please share a review and get instant rewards!

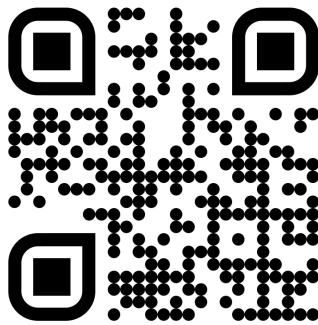

simpli-home.com/product-review



Share photos and get your cash back!

Send us images or share them on social and qualify for instant rewards. You may even receive store credit on your entire purchase!

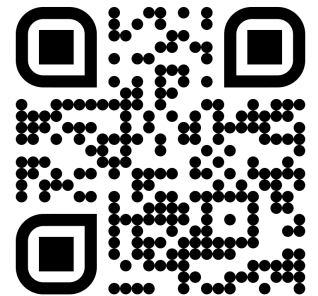
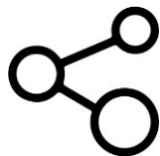

simpli-home.com/share-images

SIMPLIHOME®

For fastest customer service

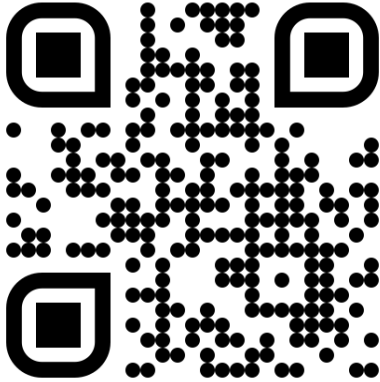

1. Open your phone's camera.
2. Point your phone's camera at the QR code to scan.
3. Click on the pop up.
4. You'll be taken to our customer service page.
5. Fill the form with your order information and issue.
6. Submit form.
7. A customer service associate will contact you.

Other ways to contact us...



Email Us

customerservice@simpli-home.com



Visit Us

Visit our site directly at
www.simpli-home.com



Call Us

1-866-518-0120
Monday to Friday
9am to 5pm EST

***If you've purchased from a retailer and you wish to return the product, please contact the retailer directly.**

IMPORTANT: Please read this manual carefully before beginning assembly of this product. Keep this manual for future reference.

Safety Information

CAUTION: Injuries and damage can occur from furniture tip over if product is not properly anchored to the wall. Use the Furniture Anti-Tipping Restraint provided with the product. Consult our assembly instructions for help.

If the Furniture Anti-Tipping Restraint kit is not in the box, please contact our customer service department in order to obtain another kit before using the furniture.

Identify all the parts and hardware. Do not discard of the packaging until you have checked that you have all the parts and hardware required. Hardware package may have spare parts.

WARNING: This item contains small parts which can be swallowed by children and pets. Keep children and pets away during assembly. To avoid danger of suffocation, always keep plastic bags away from children and pets.

We recommend that you assemble this unit on a carpeted floor to avoid scratches. If using power tools, set the tool to low torque to avoid damage.

May require 2 people for ease of assembly.

Care & Maintenance

This furniture is designed for indoor use.

Damage to furniture can come from temperature changes in relative humidity (RH) in our homes. Humid air oxidizes metal which results in rusting, corrosion, tarnishing and roughness. Wood absorbs water as relative humidity rises and falls, and in doing so it swells and shrinks.

To protect against the humidity effect, the metal is powder coated. The powder coat layer protects the metal from oxidizing, corrosion, tarnishing and scratching and keeps it looking good for years to come. The wood is sealed and lacquered to protect against humidity.

To help protect your furniture, follow these steps:

- Use a humidifier, preferably one with an automatic control system that can sense the humidity level and adjust itself accordingly
- Dust with soft dry cloth
- Wipe up spills promptly
- Clean with a dry cloth
- Do not use abrasive cleaners, chemical solvents, strong detergents, cleaners with bleach, and furniture polish
- Use soft felt base coasters, placemats to help prevent scratches
- Keep furniture out of direct sunlight, which can cause cracking or roughness on the protective layer
- If it can be avoided, do not put furniture near heating vents
- Keep the furniture 3 to 4 inches away from the wall, giving heat and air space to circulate

WARNING

The maximum diagonal CRT television screen size is 25 inch to 27 inch (63.50 cm to 68.58 cm). For use with televisions weighing 95 lbs or less. Using larger or heavier televisions may cause instability or tip over which can lead to serious injury or even death.

The recommended maximum width of the television intended for use is 66 inch (167.6 cm).

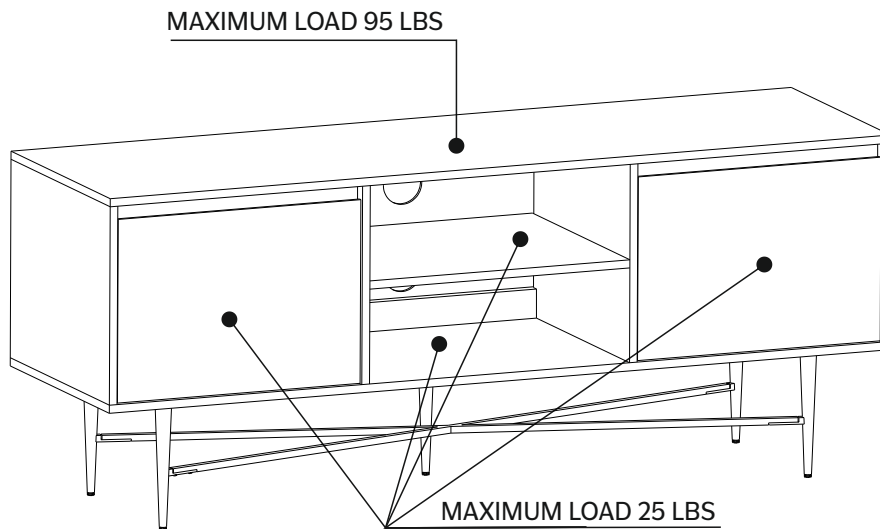

! **WARNING** Do not place toys, food, etc. on the top shelves or upper drawers. Serious injury or death may occur when children climb on furniture. A remote control or items placed on the furniture may encourage a child to climb on the furniture and as a result make it top-heavy and cause it to tip over on the child.

! **WARNING** Do not place a TV that exceeds the weight limits or size guidelines shown in the instructions specified for the furniture. Do not overload shelves or place heavy items on top shelves or drawers. Improper use of furniture to support TVs may result in serious injury or death.

! **WARNING** Do not relocate audio and/or video equipment to furniture not specifically designed to support audio and/or video equipment. Do not move furniture without shelves or drawers unloaded. Furniture can collapse or tip over onto a child and cause physical injury or death.

This TV Stand does not come with legible instructions pertaining to the risk of fire and electric shock that is associated with the use of electrical components such as operation, user-maintenance, loading, storage and as applicable electrical issues including grounding or double-insulation.

Any use of this item other than that recommended by the manufacturer in this manual may cause fire, burns, electric shock and/or serious injuries or death.

Part Description

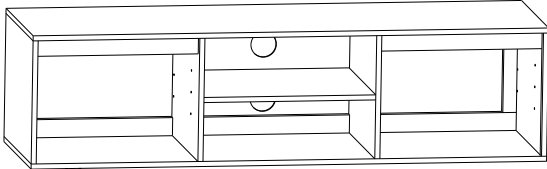
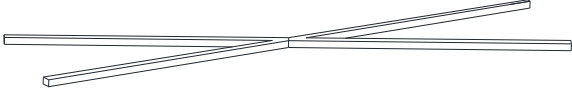
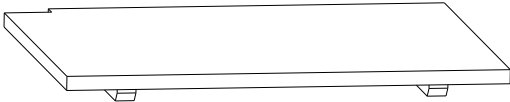
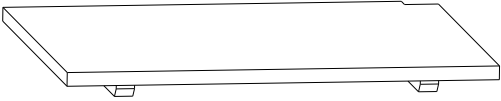
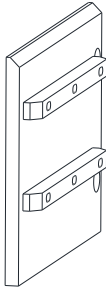
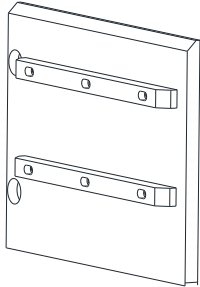
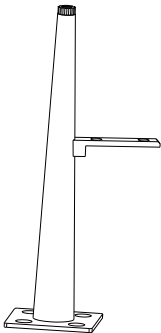
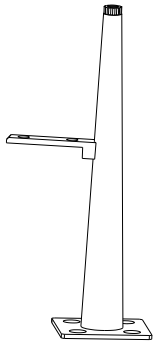
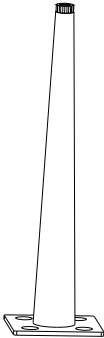
<p>A</p>  <p>CABINET QTY 1</p>	<p>B</p>  <p>X-SUPPORT QTY 1</p>	
<p>CL</p>  <p>LEFT ADJUSTABLE SHELF QTY 1</p>	<p>CR</p>  <p>RIGHT ADJUSTABLE SHELF QTY 1</p>	
<p>DL</p>  <p>LEFT DOOR QTY 1</p>	<p>DR</p>  <p>RIGHT DOOR QTY 1</p>	
<p>EL</p>  <p>LEFT LEG QTY 2</p>	<p>ER</p>  <p>RIGHT LEG QTY 2</p>	<p>F</p>  <p>CENTER LEG QTY 1</p>

Hardware Description

1

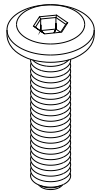

ALLEN KEY BOLT
M6 X 15mm
QTY 20

2

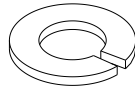

LOCK WASHER
Ø15 / Ø8 x 1.5 mm
QTY 20

3

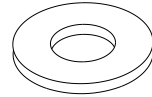

WASHER
Ø18 / Ø8 x 1.5 mm
QTY 20

4

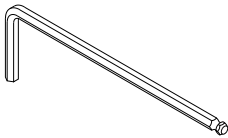

ALLEN KEY
4mm
QTY 1

5

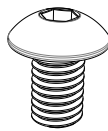

ALLEN KEY BOLT
M6 X 10mm
QTY 8

6

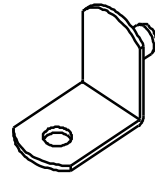

SHELF SUPPORT
QTY 8

7

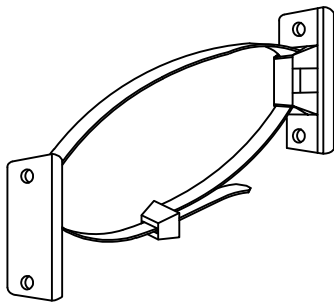

FURNITURE TIP OVER RESTRAINT
QTY - 2 SETS



QTY - 4



M4 x 20 mm - QTY - 4



M4 x 30 mm - QTY - 4

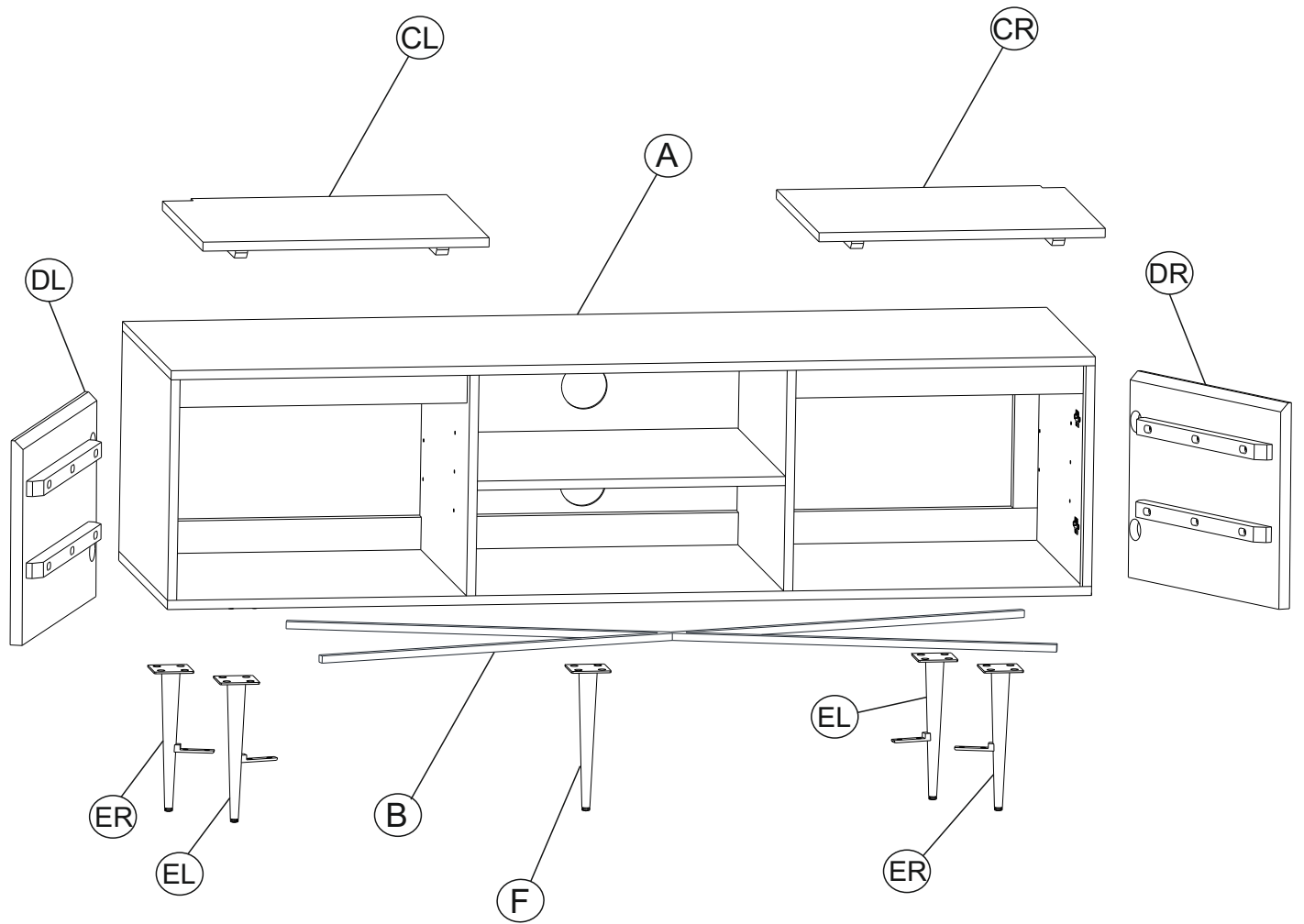

Step 1

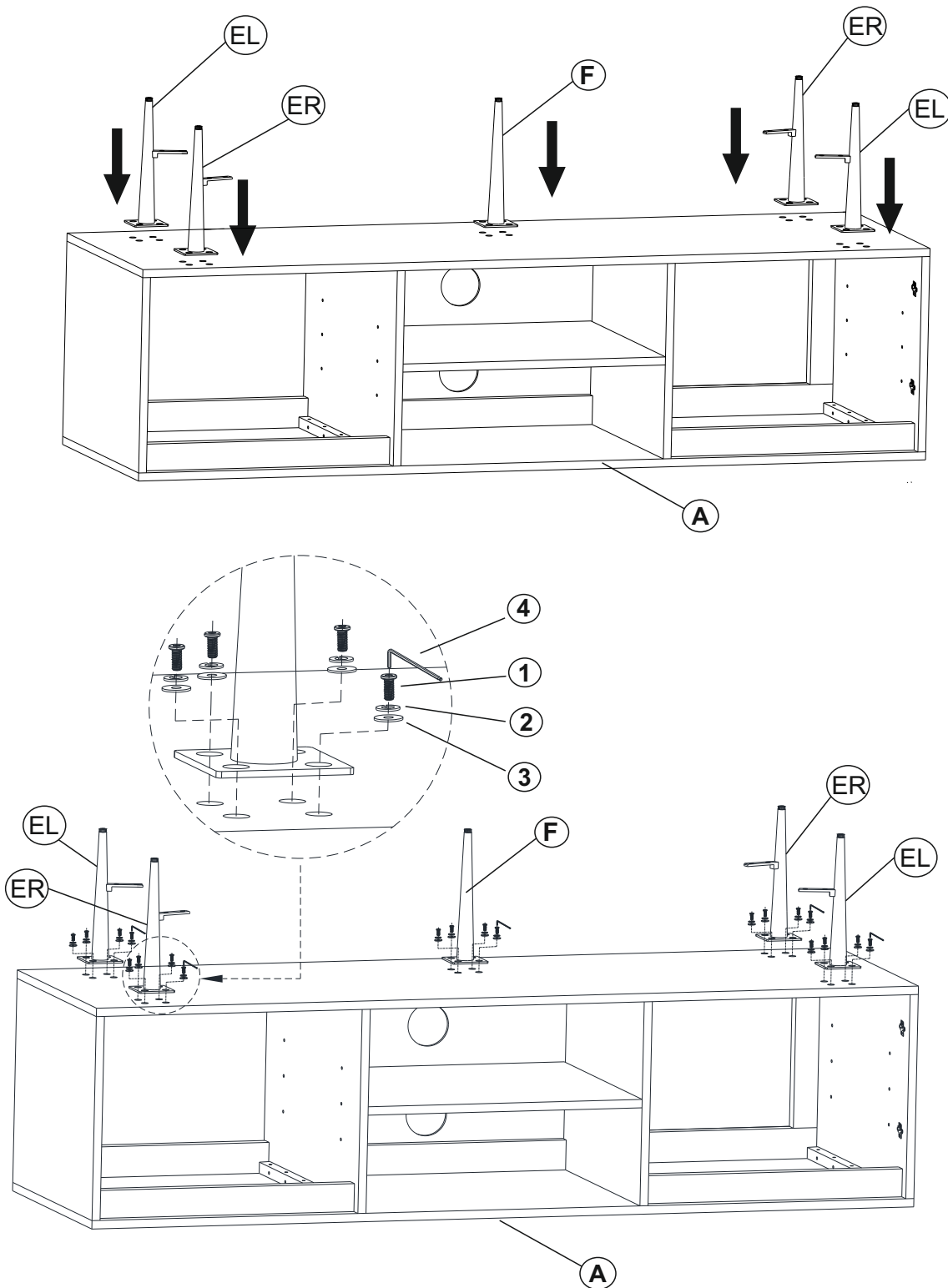

1. Place Cabinet (A) upside down on a flat, smooth surface.
2. Attach Legs (EL), (ER) & (F) to Cabinet (A) using Allen Key Bolts (1), Lock Washers (2) and Washers (3).
3. Use Allen Key (4) to tighten.

Step 2

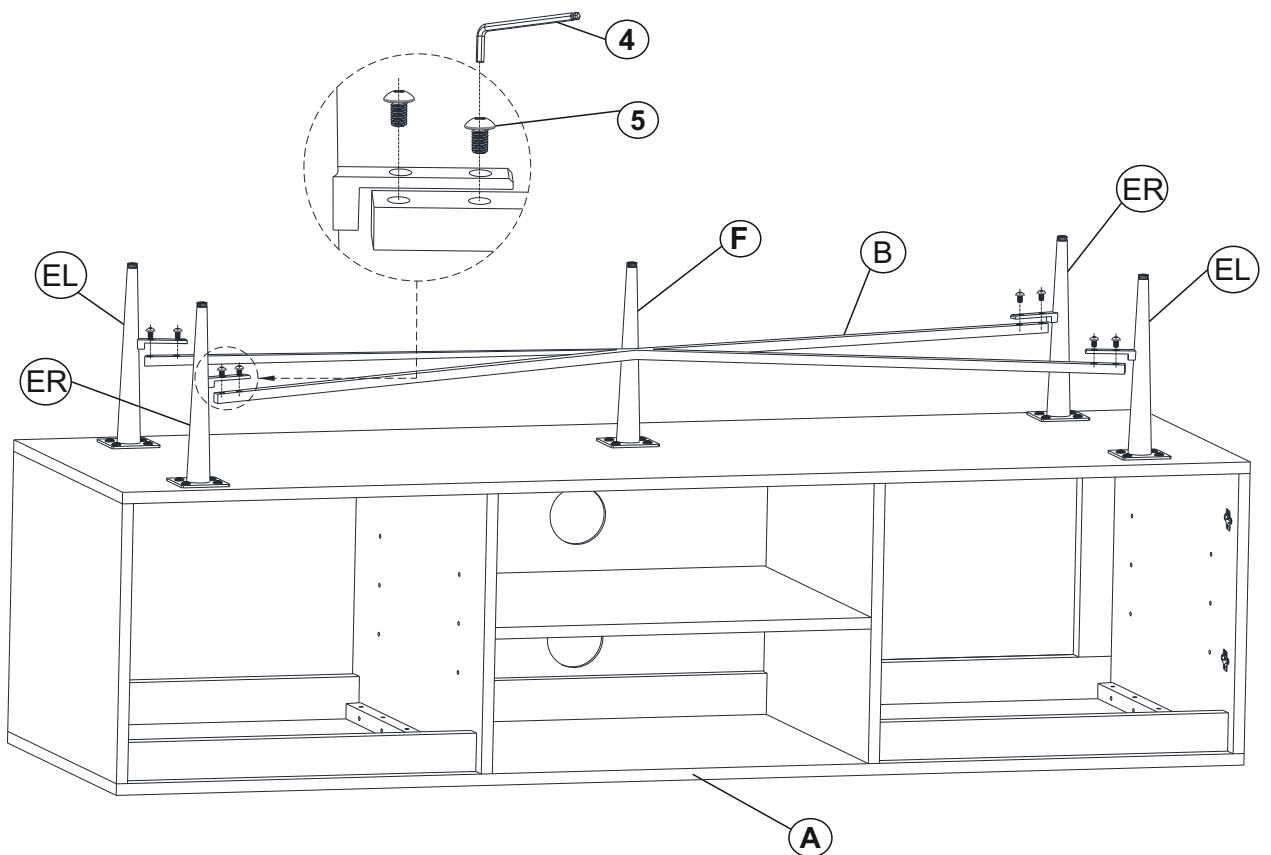
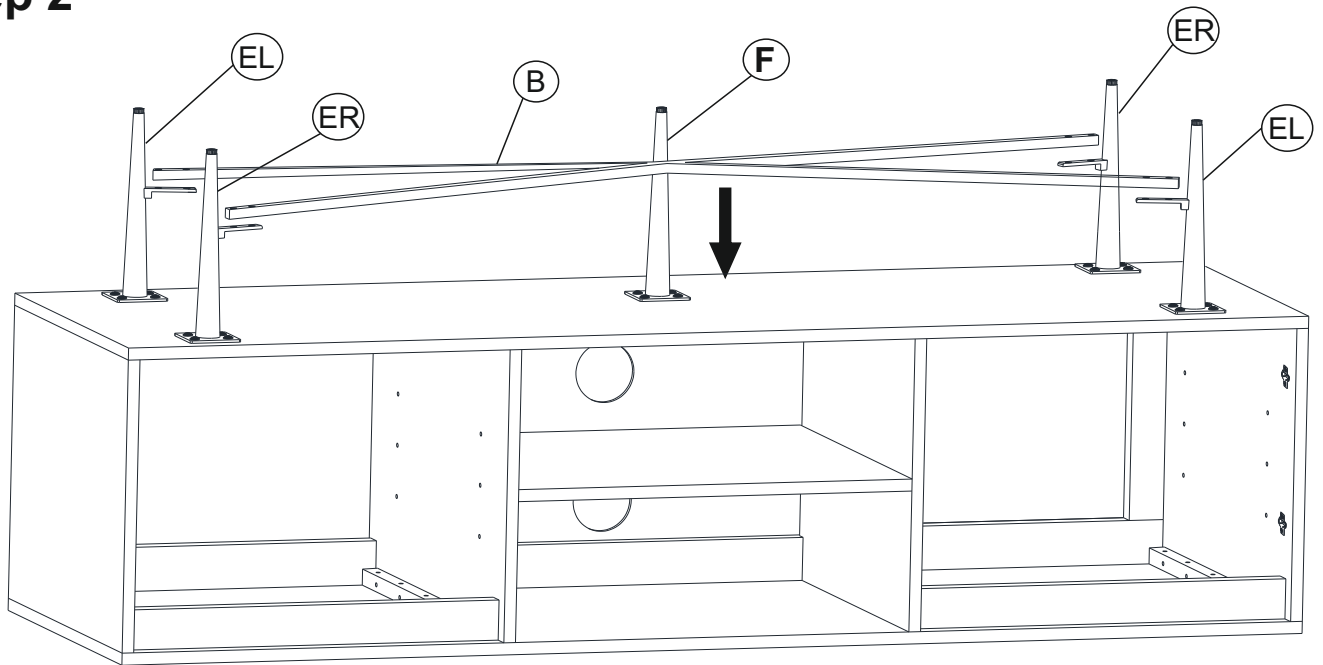

1. Attach X-Support (B) to Legs (EL) & (EL) using Allen Key Bolts (5).
2. Use Allen Key (4) to tighten.

Step 3

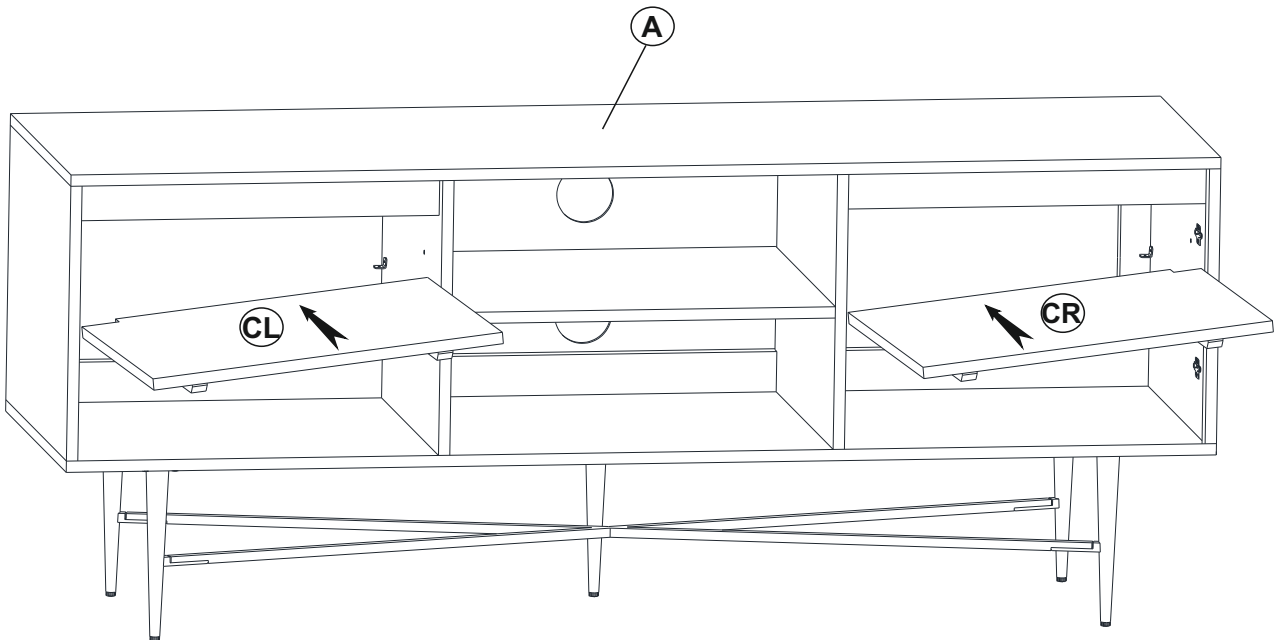
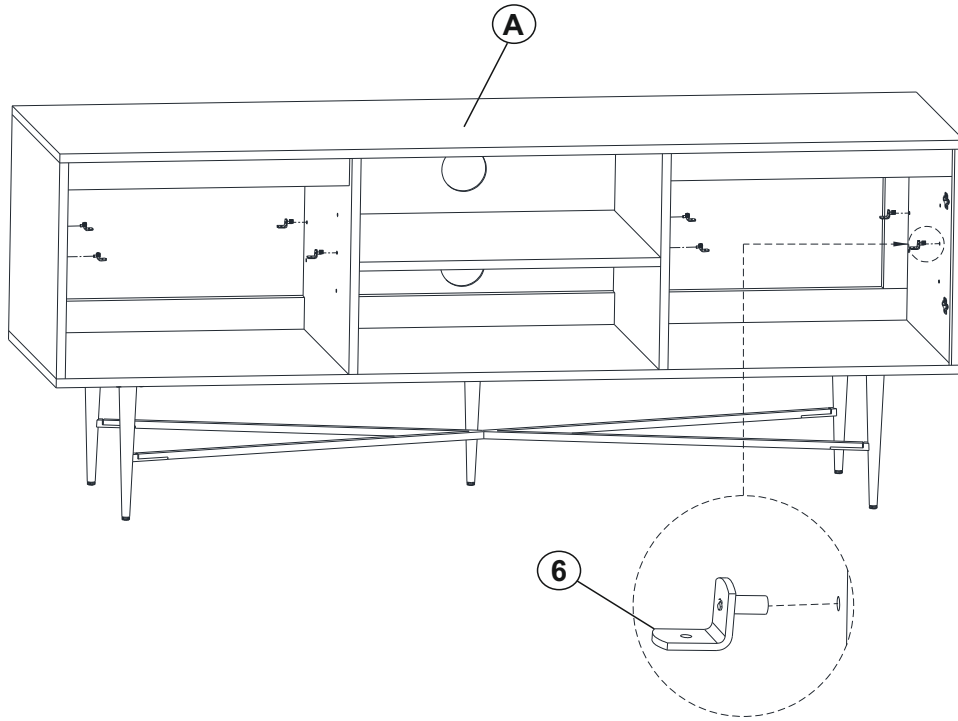

1. Insert Shelf Supports ⑥ in holes in cabinet.
2. Place Adjustable Shelves ①L & ①R in cabinet.

Step 4

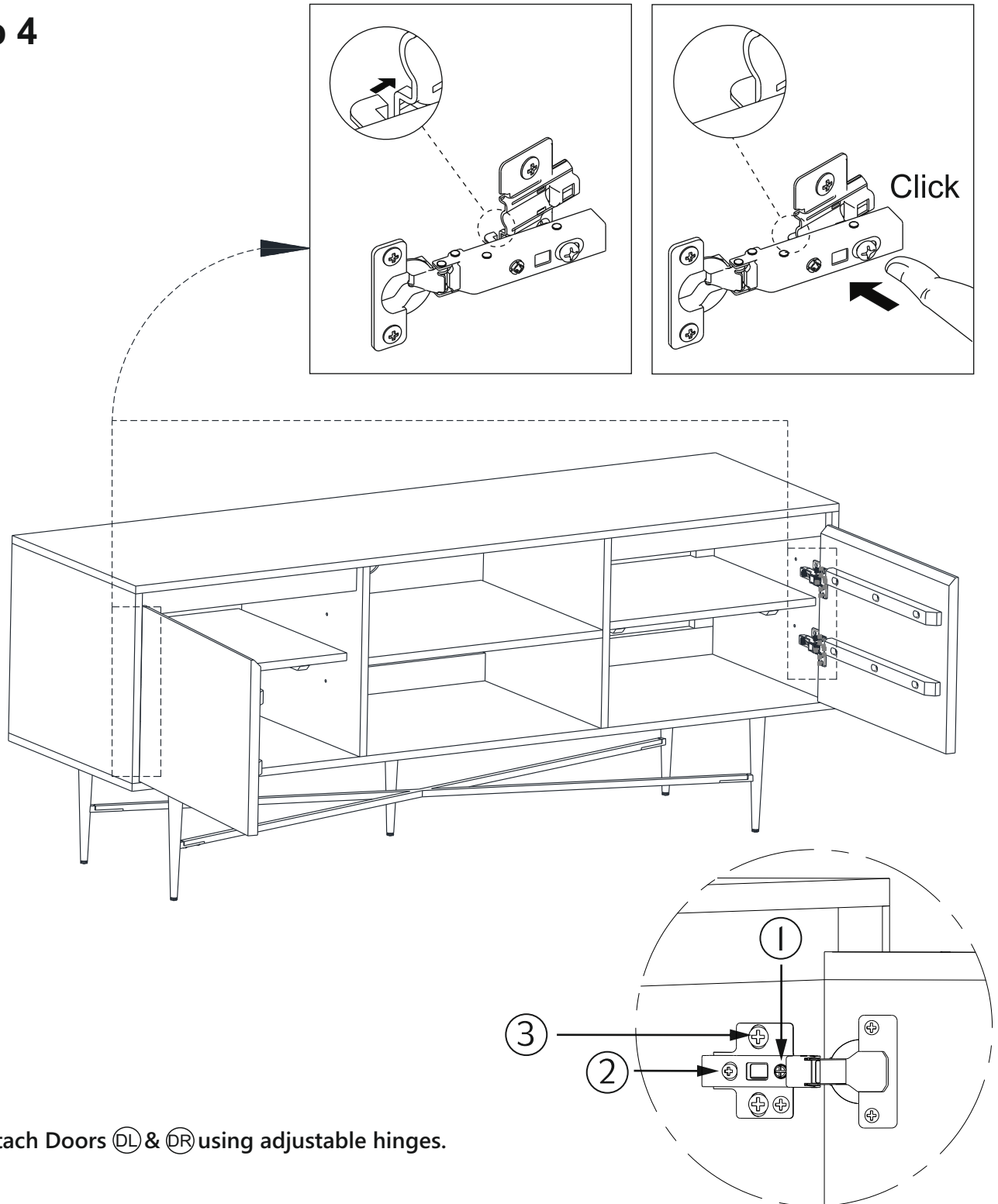

Attach Doors (DL) & (DR) using adjustable hinges.

1. Side adjustment.

To move the door towards the side panel, loosen screw (1) and To move the door away from the side panel, tighten screw (1).

2. Depth adjustment.

Loosen screw (2) (just one turn), adjust door to desired position, re-tighten screw.

3. Height adjustment

Loosen screw (3), adjust door to desired position, re-tighten screw.

Step 5

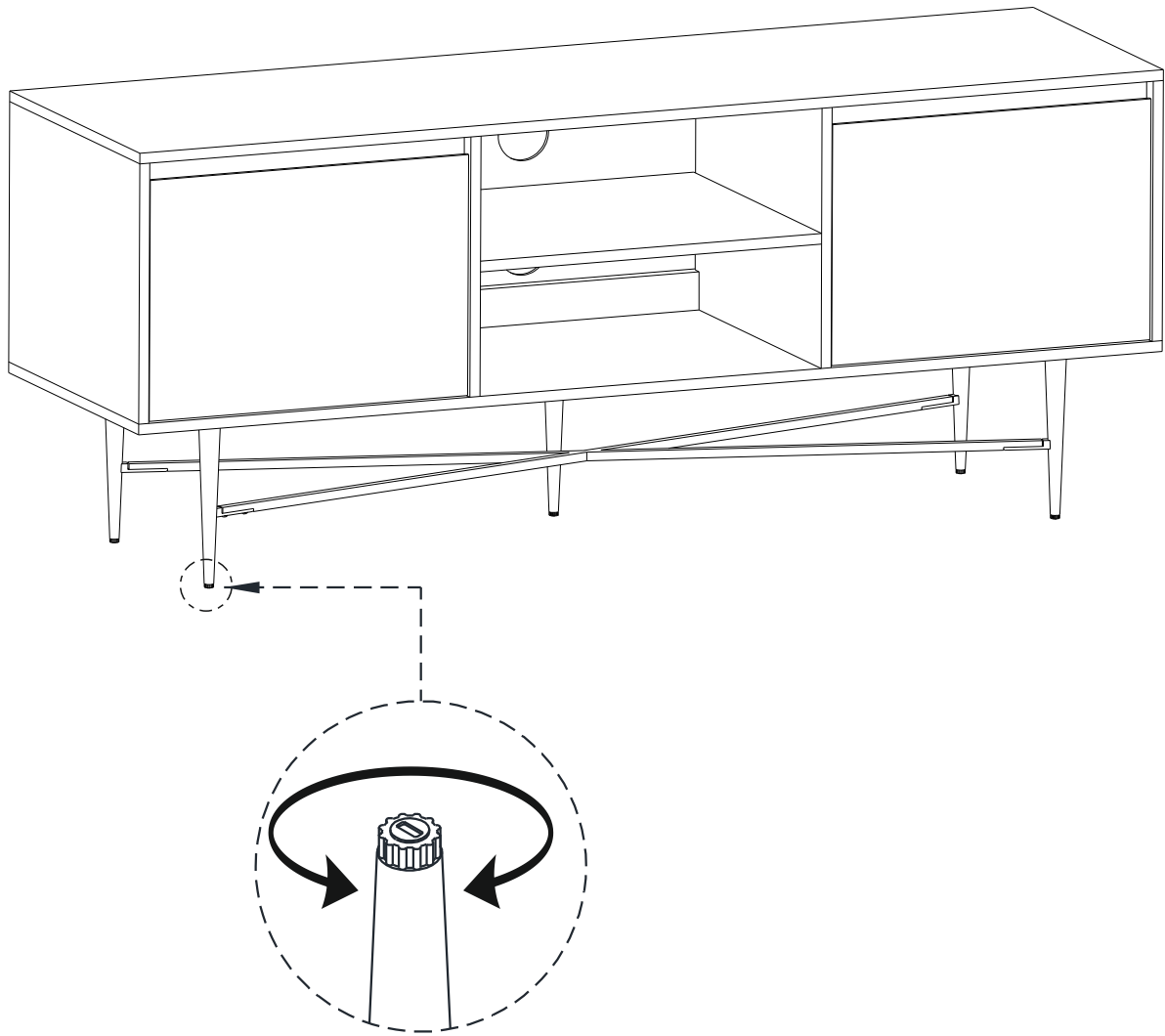

Note: Levelers on bottom of legs can be adjusted if floor is uneven.

Furniture Tip Over Restraint Assembly



WARNING

Serious or fatal crushing injuries can occur from furniture tip-over.

If the furniture tip-over restraint kit is not in the box, please contact our customer service department in order to obtain another kit before using the furniture.

Step 6

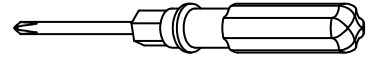

NOTE: The screwdriver is not included in the hardware pack.

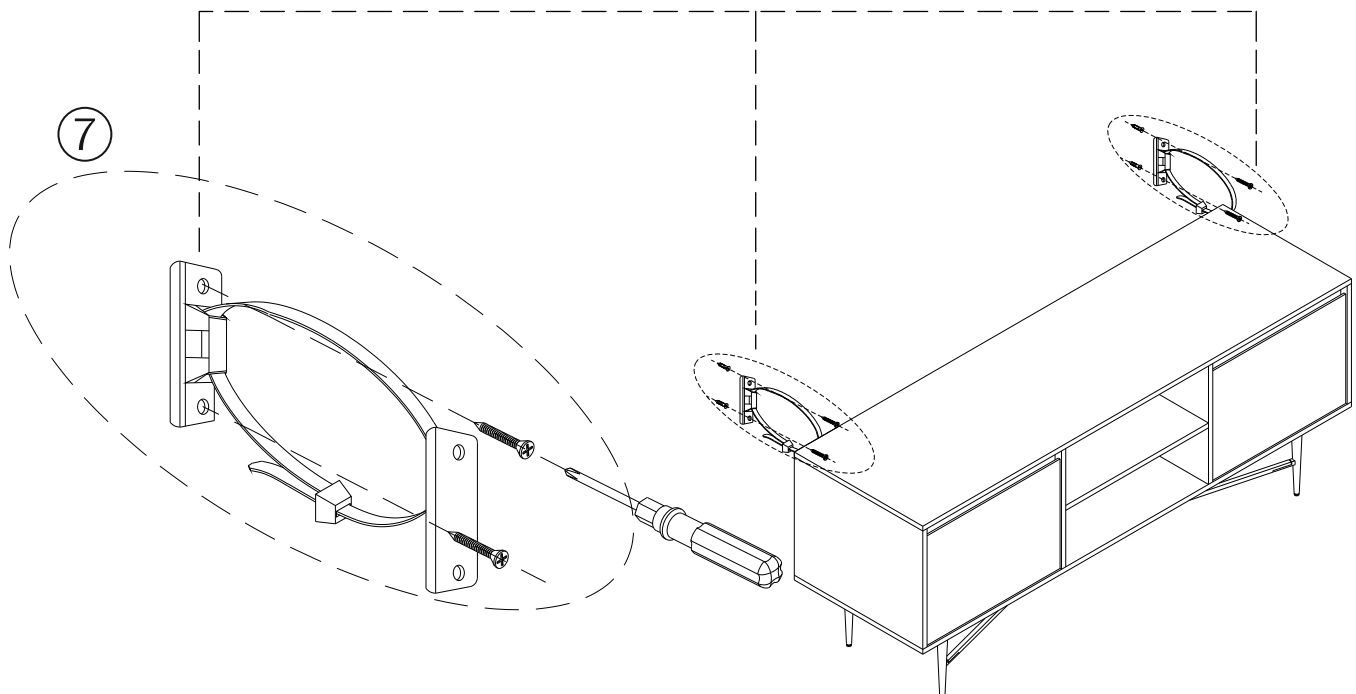
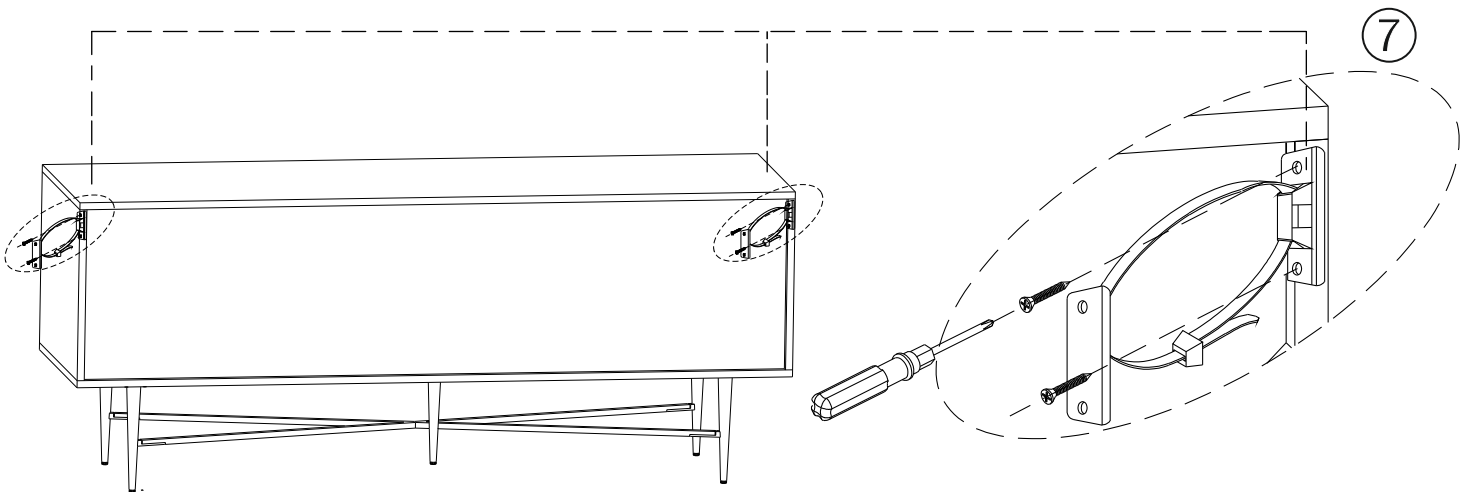

Furniture Anti-Tipping Restraint Instructions

1. Attach one of the mounting brackets securely to the back edge of the furniture. Use the shorter screw.

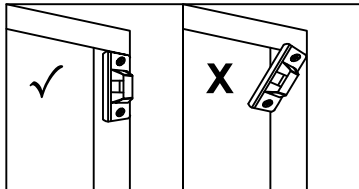

2. Determine where Furniture is to be placed and mark location on the wall for mounting bracket screw hole approximately 2 inches **below** the bracket mounted to the furniture.

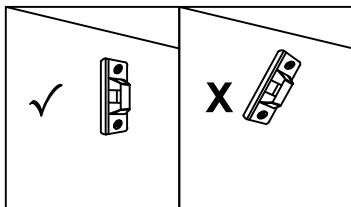

3. Drill a 3/16 inch hole in the wall. Press the plastic anchor into the hole and gently tap until the flange on the anchor is against the wall surface.
4. Position the bracket over the anchor and use the longer screw to securely attach the bracket to the wall.
5. Place the furniture so the back edge is in line with the bracket on the wall.
6. Lace an end of the nylon zip-tie strap down through each bracket. Bring both ends together and slide the smooth side upright through the square-shaped end and pull through to create the "locked" position.
7. Check to make sure the strap is securely laced and locked to the brackets.

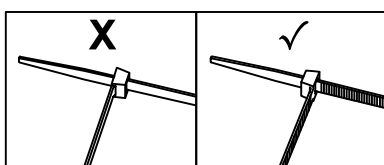

- **DO NOT** place heavy objects on top shelves
- **DO NOT** let children climb or hang on drawers, doors or shelves