

Please read the following instructions and warnings carefully. Keep this instruction manual and save for future reference.

For technical support, contact us at **1-401-671-6551** or **www.summerbyingenuity.com**.

Tools required: Phillips head screwdriver and drill (neither included).

For use with children from 6 to 24 months.

Adult assembly required.

Keep small parts away from children.

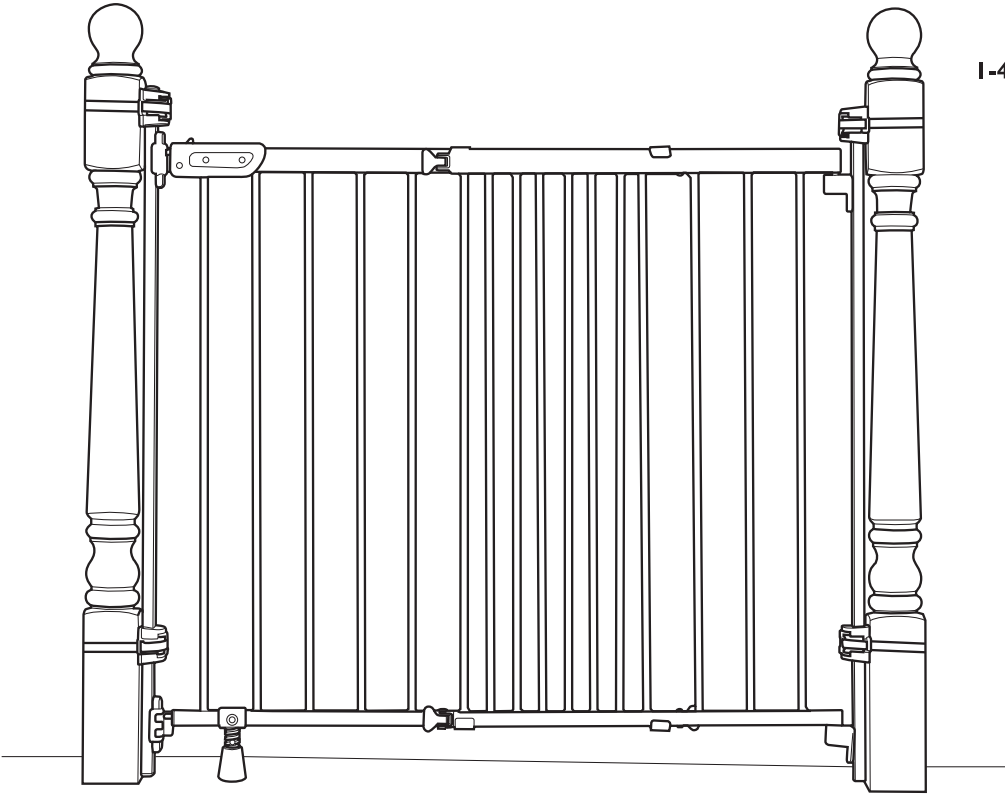

⚠ WARNING

Children have died or been seriously injured when gates are not securely installed.

- **ALWAYS** install and use gate as directed, using all required parts.
- Install according to manufacturer's instructions.
- **STOP** using when a child can climb over or dislodge the gate.
- Use only with the locking/latching mechanism securely engaged.
- **NEVER** use a gate to keep child away from pool.
- **NEVER** leave child unattended.
- **ALWAYS** close and lock the gate behind you.
- This product will not necessarily prevent all accidents. Proper adult supervision is required at all times.

- Do not use if any components are missing or damaged.
- Adult assembly required. Exercise care when unpacking and assembling product.
- Intended for use with children from 6 months through 24 months.
- Do not mount to spindles less than 2 in. in diameter.
- Check daily that banister brackets are securely attached and gate is securely anchored to banisters and/or wall.
- **FALL HAZARD:** NEVER allow child near gate until it is locked and secured.

⚠ CAUTION KEEP SMALL PARTS OUT OF CHILD'S REACH.

MANUFACTURED FOR • FABRIQUÉ POUR **kids2™** **OKids II®** ©2023 KIDS2, INC. www.kids2.com/help

KIDS2, INC. ATLANTA, GA USA 30305 • 1-800-230-8190

IMPORTED BY • IMPORTÉ PAR

SUMMER INFANT (USA) INC. 1275 PARK EAST DRIVE, WOONSOCKET, RI 02895 USA • 1-401-671-6551

KIDS2 CANADA CO. PO BOX 54059, RPA LAWRENCE PLAZA, TORONTO, ON. M6A 3B7

KIDS2 AUSTRALIA PTY LIMITED CASTLE HILL, NSW AUSTRALIA 2154 • (02) 9894-1855

KIDS2 JAPAN K.K. c/o ARK Outsourcing KK 4-3-5-704, Ebisu, Shibuya-ku, Tokyo, Japan 150-0013 • (03) 5322-6081

KIDS2 UK LTD. GROUND FLOOR, SUITE A1A, BREAKSPEAR PARK, BREAKSPEAR WAY, HEMEL HEMPSTEAD, HP2 4TZ • +44 01582 816 080

KIDS2 EUROPE BV 5 KEIZERS, KEIZERSGRACHT 287, 1016 ED AMSTERDAM, NETHERLANDS • +31 20 2410934

KIDS2 US MÉXICO S.A. DE C.V. • (55) 5292-8488

MADE IN CHINA • HECHO EN CHINA • FABRIQUÉ EN CHINE

Colors and styles may vary.

MADE IN CHINA.

components:

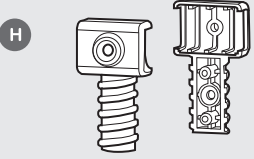
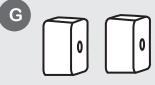
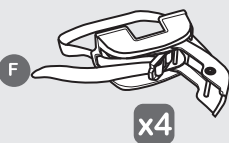
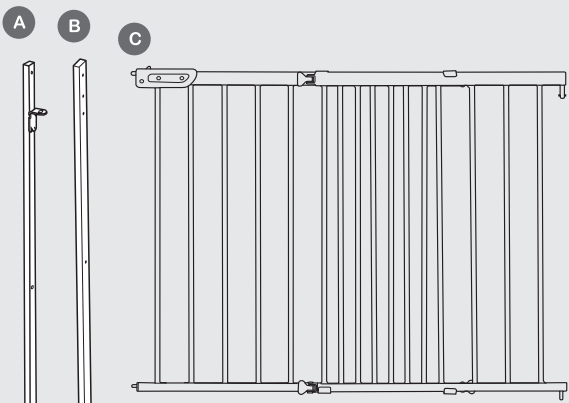

Tools required (not included)
 Phillips head screwdriver
WALL MOUNT OPTION ONLY:
 Drill with 7/32" drill bit
WOOD MOUNT OPTION ONLY:
 Pre-drill with 1/8" drill bit

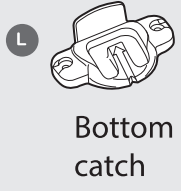
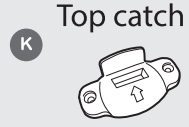
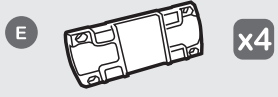
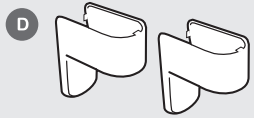

- A Left gate mount
- B Right gate mount
- C Gate
- D Hinge bracket covers (2)
- E Banister plate/foam pad (4)
- F Banister latch strap base (4)
- G Banister wall spacer (2)

- H Support foot screw components
- I Support foot
- J Extra foam pads (4)
- K Top latch catch
- L Bottom latch catch
- M Support foot screw
- N Bottom support foot screw
- O Wall screws (6)
- P Wall anchors (6)
- Q Washers (2)
- R Top / bottom catch screws (4)

hardware:

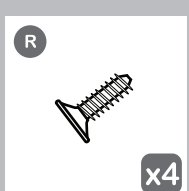
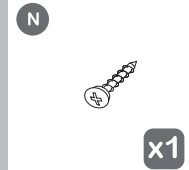
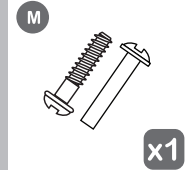

Gate fits openings 31" to 46" (79cm to 117 cm) !

IMPORTANT: Place the gate on top landing at a distance of 3 in. from the edge of top stair or the furthest it can be placed based on the size and locations of your banisters.

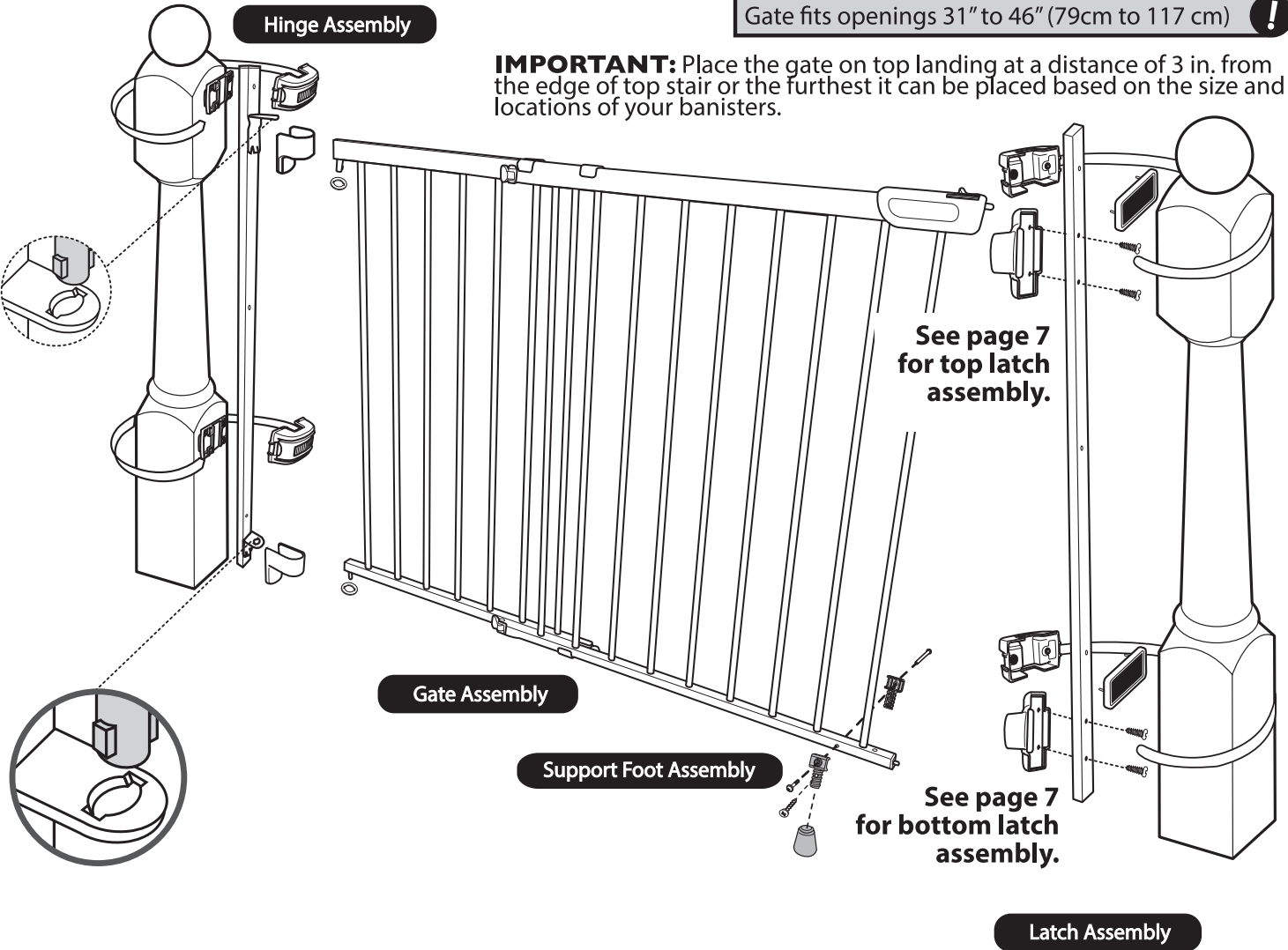

Gate Assembly

Support Foot Assembly

Latch Assembly

See page 7 for top latch assembly.

See page 7 for bottom latch assembly.

maintenance:

- Check all hardware to ensure gate is securely in place.
- Do not use gate if any of the components are damaged or missing.
- Wipe surface with a damp cloth or sponge, using mild detergent and warm water to clean. Towel dry.

1. Hinge Assembly

CHOOSE WHICH OF THE TWO OPTIONS WITHIN THE HINGE ASSEMBLY SECTION BEST FITS YOUR NEEDS.

Option A:

Square Top Banister (No drilling necessary)

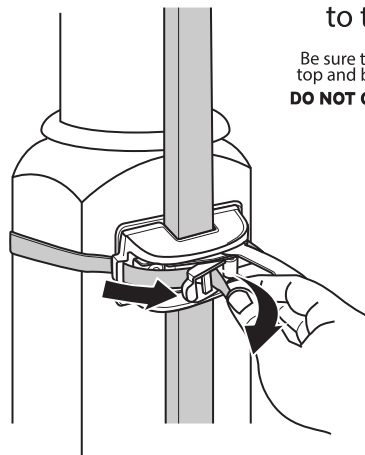
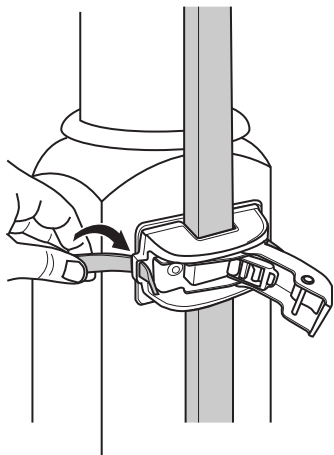
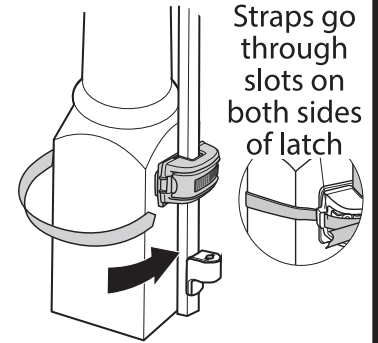
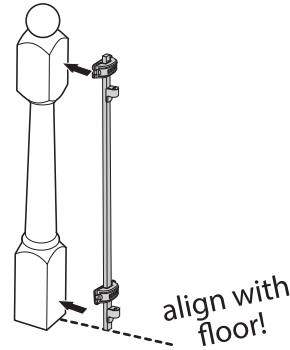
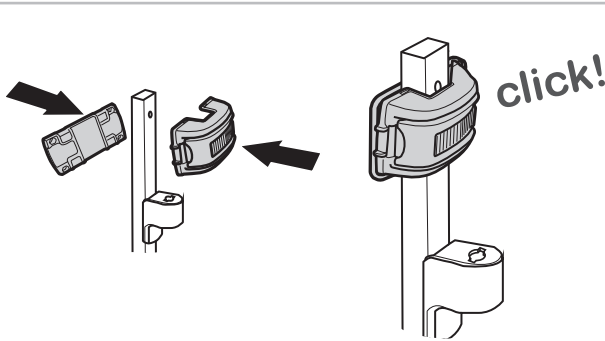
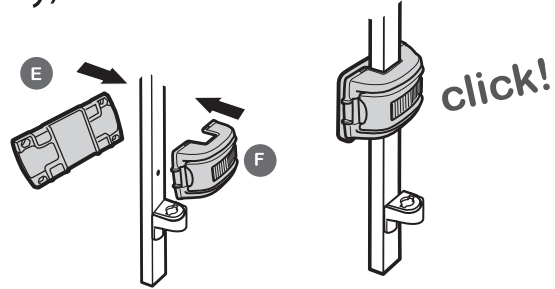
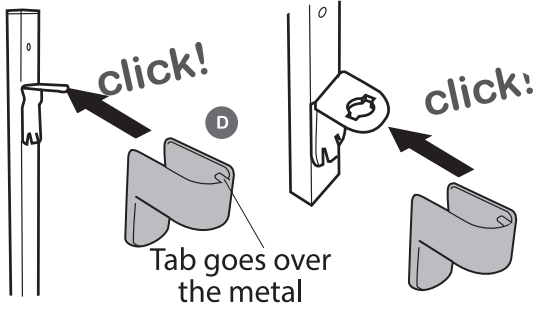
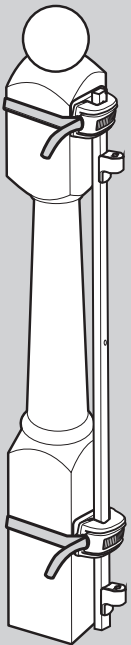

to tighten

Be sure to tighten both top and bottom bracket!
DO NOT OVER TIGHTEN!

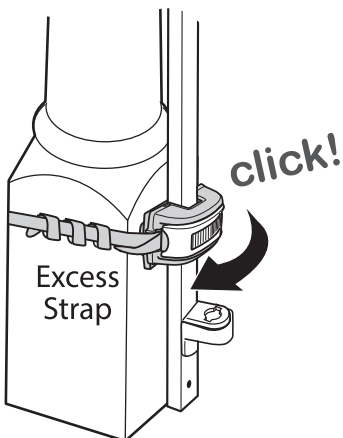
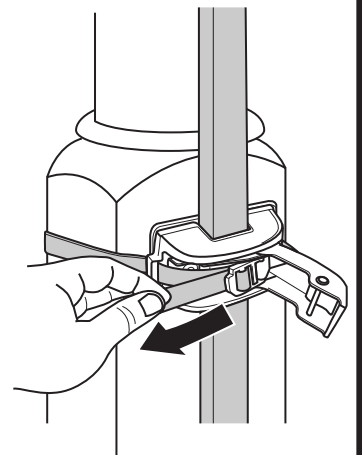
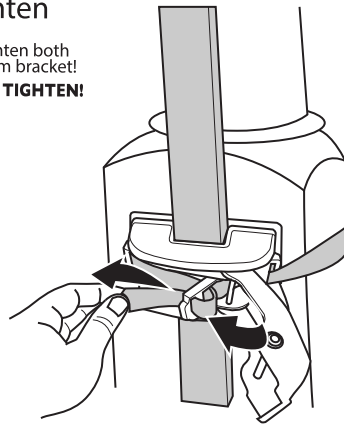

IMPORTANT NOTE:

There are extra mounting pads provided to stick to the metal hinge assembly in order to protect the wood of your banister. Peel and stick the back of the metal hinge assembly before assembling onto the banister.

The pad is intended to help position the metal hinge bracket so that it is on a flat surface.

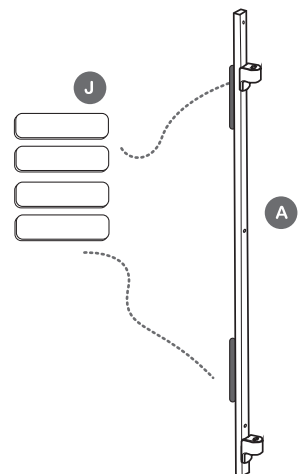

1. Hinge Assembly

Option B:

Wall Mount

wood wall !

or

wallboard !



Pre-drill a hole using a 1/8" or 3mm.

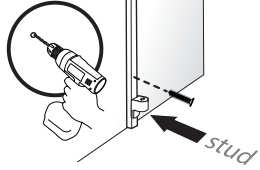

Pre drill holes using 7/32" (5.5mm) drill bit. Use pre-existing holes in your banister bracket as your guide. Insert Wall Anchors into the hole with a hammer, tap gently on end until the Wall Anchor is flush with the wall.

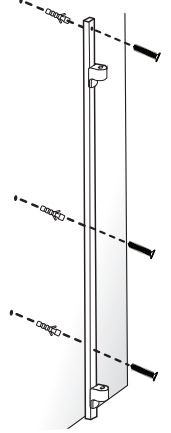
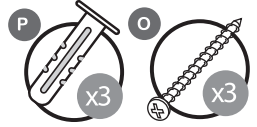
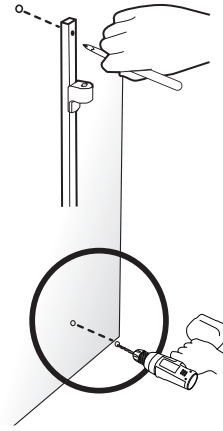

wood wall with baseboard !

or

wallboard with baseboard !

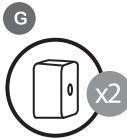
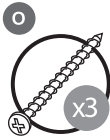

IMPORTANT:
If baseboard exists, use spacer. If there is no baseboard, attach to wall directly.

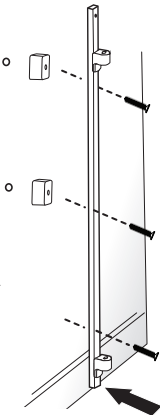
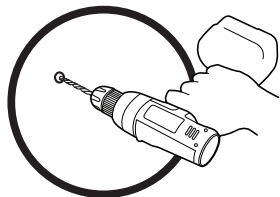
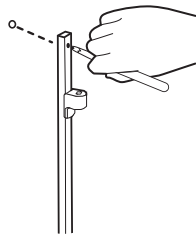

Pre-drill a hole using a 1/8" or 3mm.



IMPORTANT:
If baseboard exists, use spacer. If there is no baseboard, attach to wall directly.

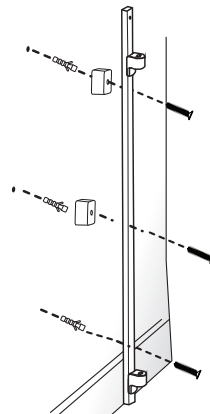

2. Gate Assembly - Wall

IMPORTANT:
At the top of the landing, position the gate a minimum of 3-6 inches (8-15cm) away from the top step.

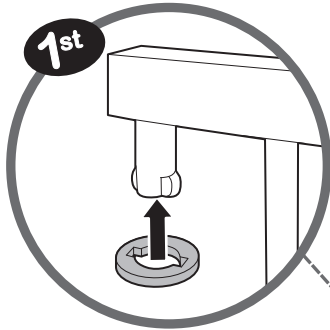
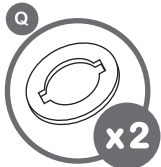

Add Plastic Inserts (part Q) to the Upper and Lower Hinge Bolts.

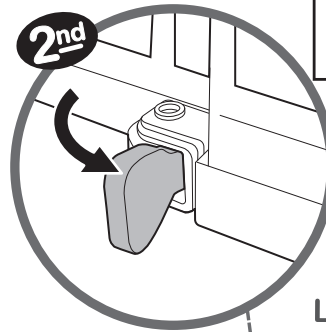

Unlock all 4 Locks on Gate.

IMPORTANT:
The Gate should never open over the stairs. The protrusion on the latch will prevent the gate from swinging both ways.

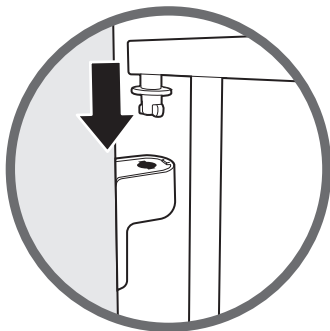

With the Gate 90° to the Hinges (open position), lower Gate into openings on hinges.

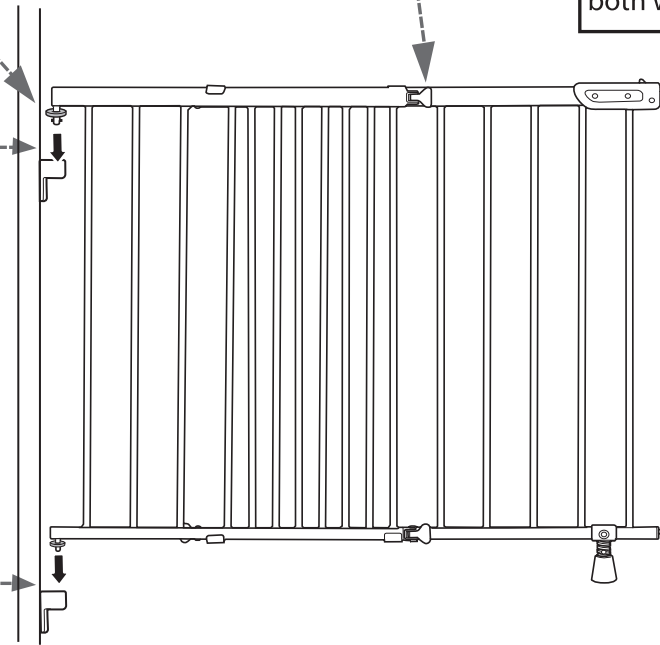
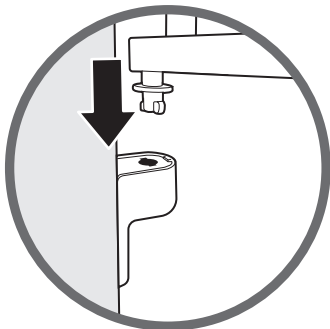

Support Foot Assembly:

IMPORTANT NOTE:
Adjust foot to be just touching floor when gate is locked closed.

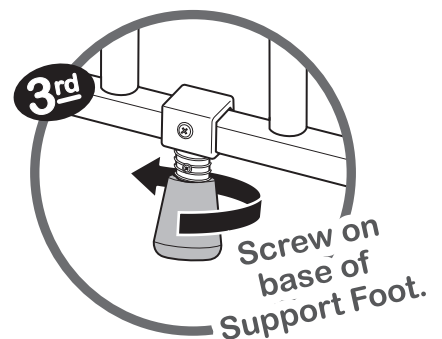
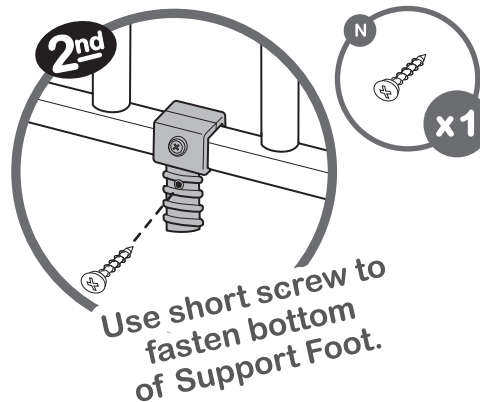
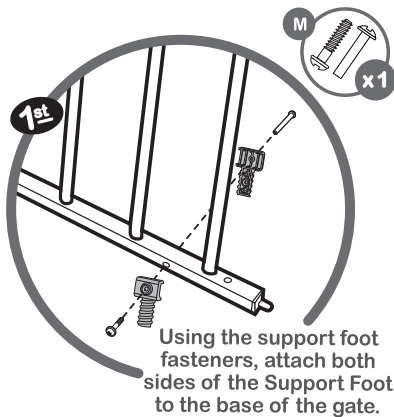

2. Gate Assembly - Banister

IMPORTANT:

At the top of the landing, position the gate a minimum of 3-6 inches (8-15cm) away from the top step.

IMPORTANT:

The Gate should never open over the stairs. The protrusion on the latch will prevent the gate from swinging both ways.

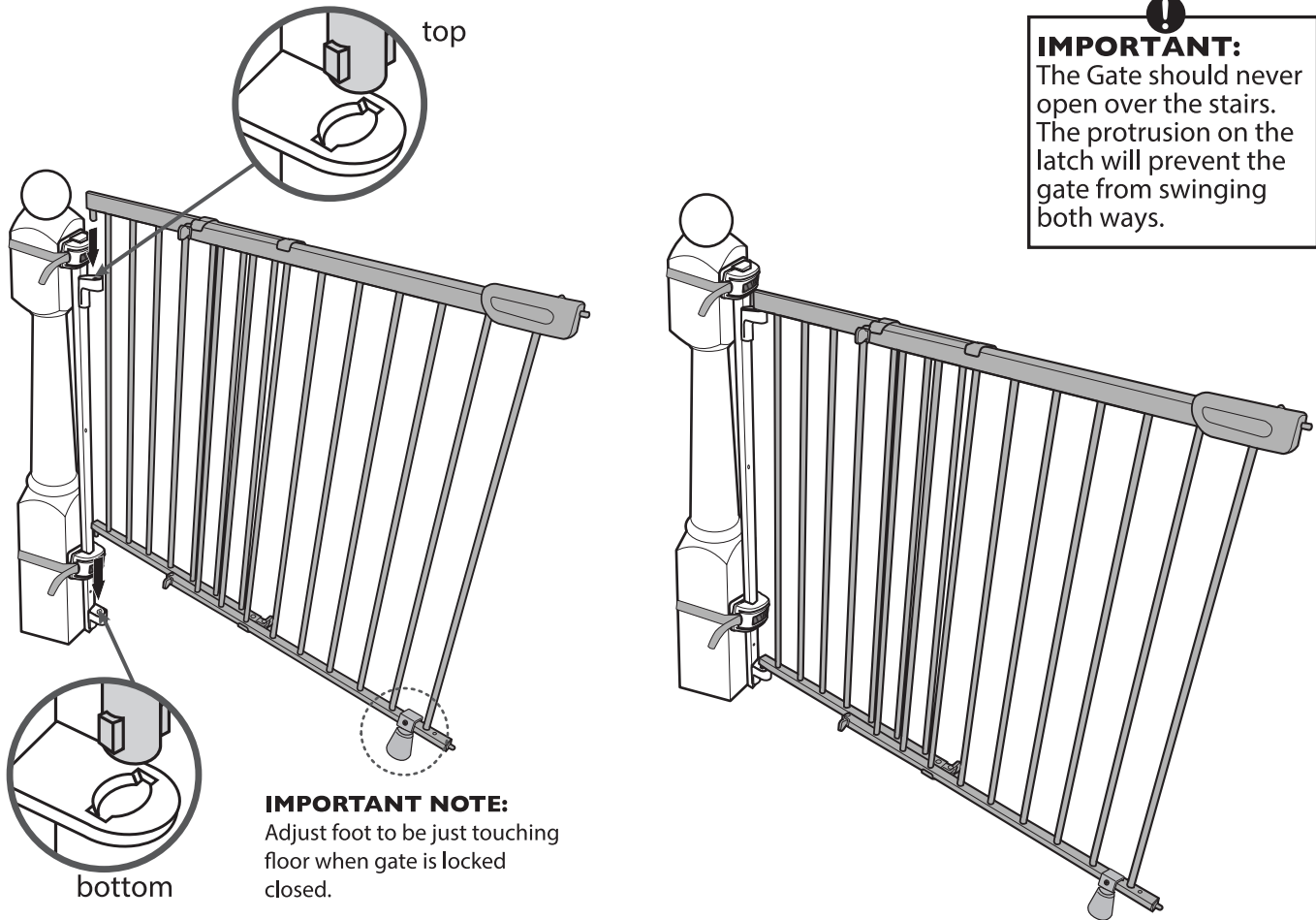

3. Latch Assembly

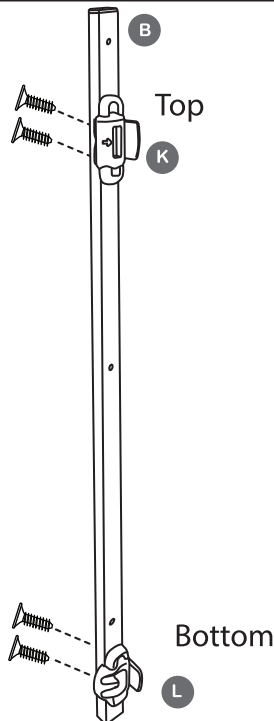
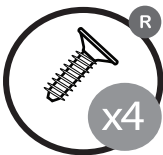

4. Latch Assembly (cont.)

Latch Assembly is identical to Hinge Assembly. Choose which of the two options best fits your needs.

Banister

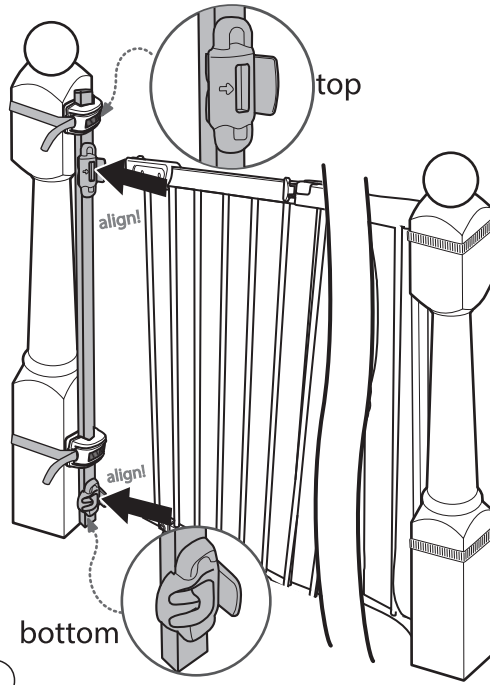

Square Top Banister

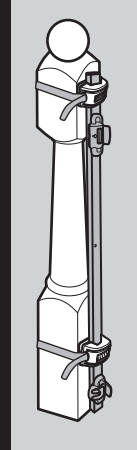

Repeat Assembly Option A

Wall Mounted

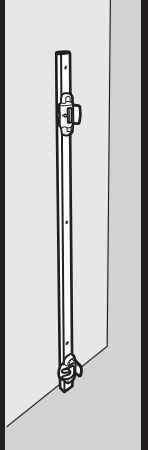

Repeat Assembly Option B

Banister to Wall

There should be 1/16" (1.6 mm) space between the Gate and the Bottom Latch Catch.

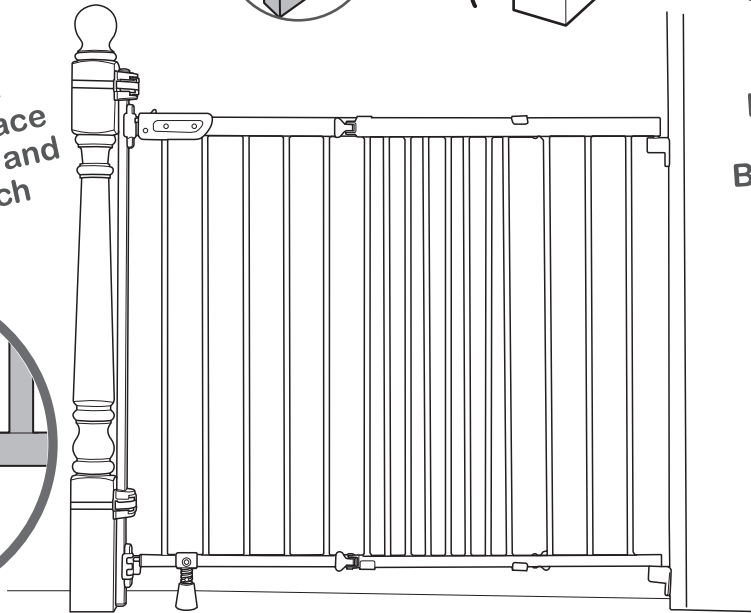
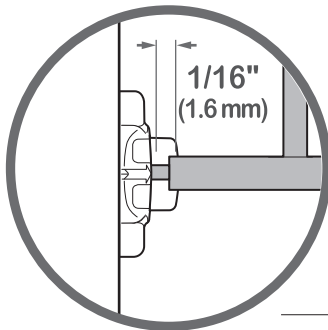

Push Gate until handle engages & locks in Top and Bottom Latch Catch.

Operating Instructions

CLOSING THE GATE:

Push Gate until handle engages & locks in Top and Bottom Latch Catch.

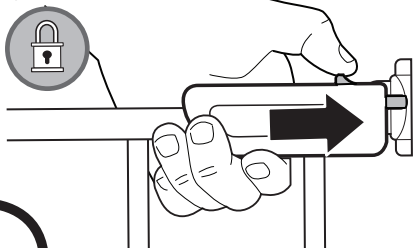

OPENING THE GATE:

Pull back thumb pad, lift and open Gate.

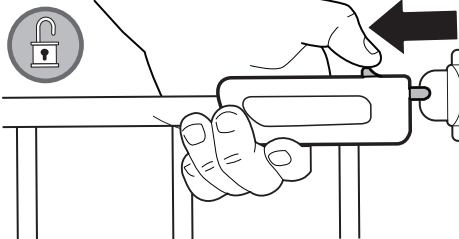

REMOVING THE GATE:

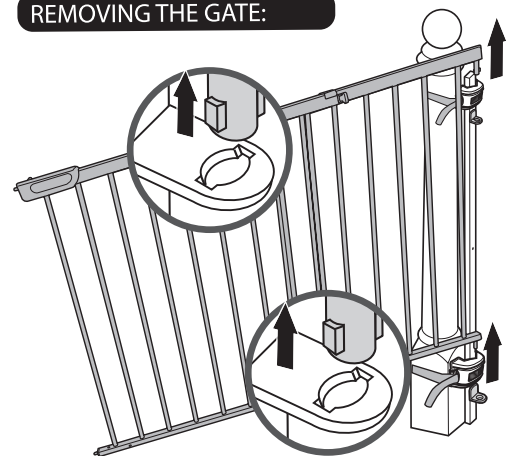

MODE D'EMPLOI

Lire attentivement les instructions et les avertissements.
Conserver ce mode d'emploi pour toute consultation ultérieure.

Pour obtenir une assistance technique, il vous suffit de communiquer avec nous au **1-905-456-8484** ou d'aller sur le site **www.summerbyingenuity.com**.

Outils nécessaires : tournevis cruciforme et perceuse (non fournis).

Conçu pour une utilisation avec des enfants de 6 à 24 mois.

Doit être assemblée par un adulte. Garder les petites pièces à l'écart des enfants.

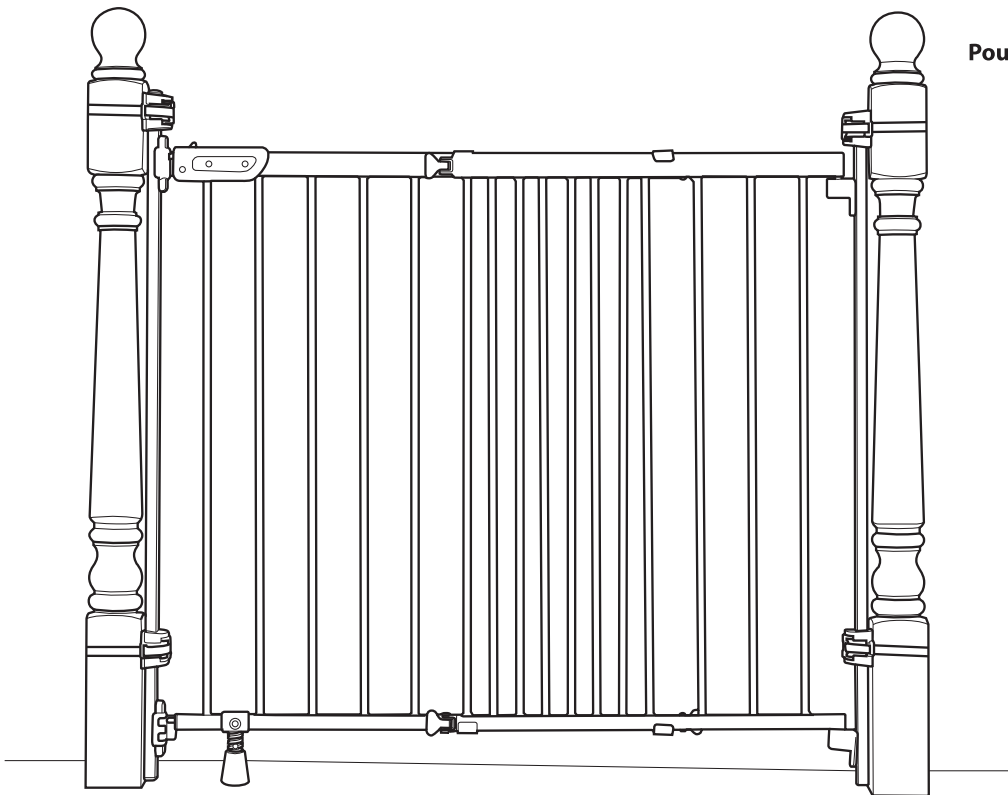

⚠️ AVERTISSEMENT

Des enfants sont morts ou ont été grièvement blessés lorsque les barrières n'étaient pas installées de façon sécuritaire.

- **TOUJOURS** installer et utiliser la barrière selon les instructions en utilisant toutes les pièces nécessaires.
- Installer selon les instructions du fabricant.
- **ARRÊTER** lorsqu'un enfant peut grimper par-dessus ou déloger la barrière.
- Utiliser uniquement lorsque le mécanisme de verrouillage ou blocage est bien bloqué.
- **NE JAMAIS** utiliser une barrière pour tenir l'enfant éloigné de la piscine.
- **NE JAMAIS** laisser l'enfant sans surveillance.
- **TOUJOURS** fermer et verrouiller la barrière derrière vous.

- Ce produit ne préviendra pas nécessairement tous les accidents. La supervision par un adulte est impérative en tout temps.
- Ne pas utiliser si des éléments sont manquants ou endommagés.
- Doit être assemblée par un adulte. Prendre les précautions nécessaires lors du déballage et de l'assemblage du produit.
- Conçue pour une utilisation avec des enfants de 6 à 24 mois.
- Ne pas monter sur des balustres d'un diamètre inférieur à 5,08 cm (2 po).
- Vérifier tous les jours que les supports de la balustrade sont bien fixés et que la barrière est fermement ancrée aux balustrades ou au mur.
- **RISQUE DE CHUTE** : NE JAMAIS laisser un enfant s'approcher de la barrière tant qu'elle n'est pas verrouillée et sécurisée.

⚠️ **ATTENTION** : GARDER LES PETITES PIÈCES HORS DE LA PORTÉE DES ENFANTS.

MANUFACTURED FOR • FABRIQUÉ POUR **kids2™** **OKids II®** ©2023 KIDS2, INC. www.kids2.com/help

KIDS2, INC. ATLANTA, GA USA 30305 • 1-800-230-8190

IMPORTED BY • IMPORTÉ PAR

SUMMER INFANT (USA) INC. 1275 PARK EAST DRIVE, WOONSOCKET, RI 02895 USA • 1-401-671-6551

KIDS2 CANADA CO. PO BOX 54059, RPA LAWRENCE PLAZA, TORONTO, ON. M6A 3B7

KIDS2 AUSTRALIA PTY LIMITED CASTLE HILL, NSW AUSTRALIA 2154 • (02) 9894-1855

KIDS2 JAPAN K.K. c/o ARK Outsourcing KK 4-3-5-704, Ebisu, Shibuya-ku, Tokyo, Japan 150-0013 • (03) 5322-6081

KIDS2 UK LTD. GROUND FLOOR, SUITE A1A, BREAKSPEAR PARK, BREAKSPEAR WAY, HEMEL HEMPSTEAD, HP2 4TZ • +44 01582 816 080

KIDS2 EUROPE BV 5 KEIZERS, KEIZERSGRACHT 287, 1016 ED AMSTERDAM, NETHERLANDS • +31 20 2410934

KIDS2 US MÉXICO S.A. DE C.V. • (55) 5292-8488

MADE IN CHINA • HECHO EN CHINA • FABRIQUÉ EN CHINE

Les couleurs
et modèles peuvent varier.

FABRIQUÉ EN CHINE.

composants :

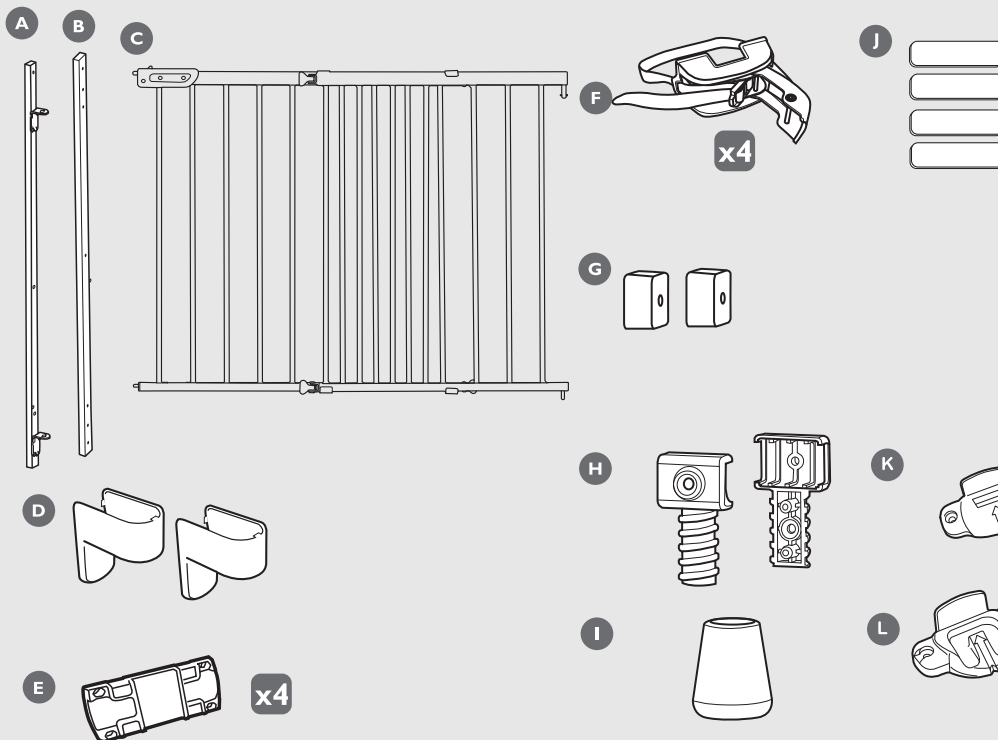

- A** Montant gauche de la barrière
- B** Montant droit de la barrière
- C** Barrière
- D** Protections des charnières (2)
- E** Plaques avec coussinet de mousse pour balustrade (4)
- F** Supports avec loquet et courroie de maintien pour balustrade (4)
- G** Entretoises murales pour balustrade (2)
- H** Pièces de vissage du pied de support
- I** Pied de support
- J** Coussinets en mousse supplémentaires (4)
- K** Loquet du haut
- L** Loquet du bas
- M** Vis pour pied de support
- N** Vis pour la base du pied de support
- O** Vis murales (6)
- P** Ancrages muraux (6)
- Q** Rondelles (2)
- R** Vis du loquet du haut et du bas (4)

Outils nécessaires (non fournis)

Tournevis cruciforme

OPTION DE FIXATION MURALE

UNIQUEMENT : Percer avec une mèche de 5,5 mm (7/32 po)

OPTION DE FIXATION À DU BOIS

UNIQUEMENT : Percer au préalable avec une mèche de 3,2 mm (1/8 po)

matériel de fixation :

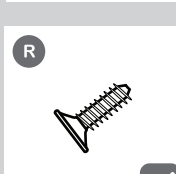
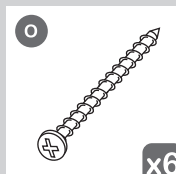
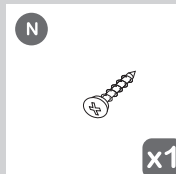
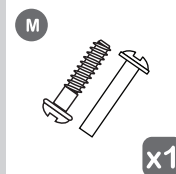

Montage de la charnière

La barrière s'adapte aux ouvertures de 79 à 117 cm (31 à 46 po) !

IMPORTANT : Placer la barrière au sommet du palier à une distance de 7,62 cm (3 po) du bord de la marche supérieure ou le plus loin qu'elle puisse être fixée selon la taille et l'emplacement des balustrades.

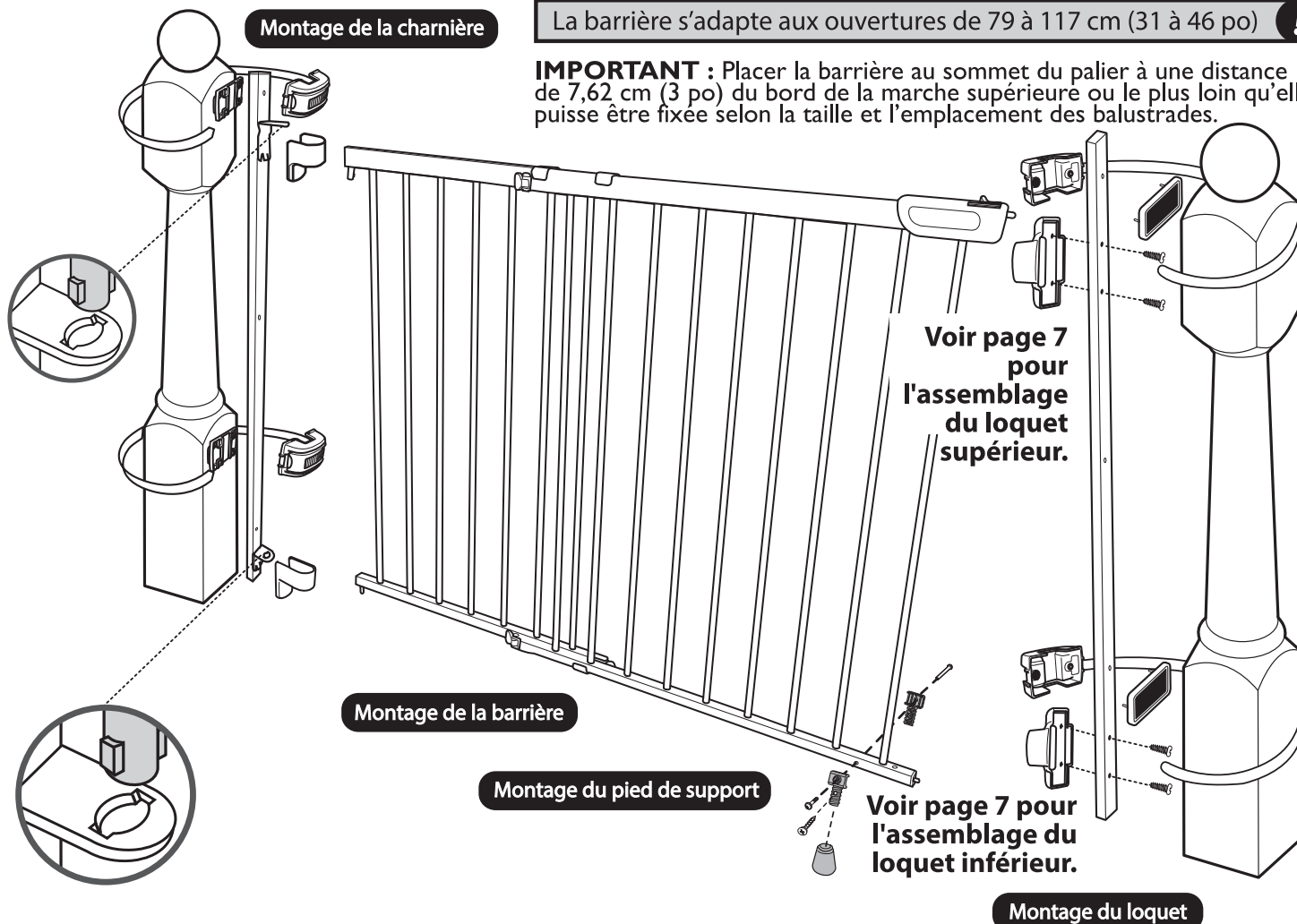

entretien :

- Vérifier tout le matériel de fixation pour s'assurer que la barrière est bien installée.
- Ne pas utiliser la barrière si des pièces sont endommagées ou manquantes.
- Essuyer la surface avec un linge ou une éponge légèrement humectés de savon doux et d'eau tiède propre. Sécher avec une serviette.

1. Montage de la charnière

CHOISIR L'OPTION LA PLUS ADAPTÉE DANS LA RUBRIQUE DE MONTAGE DE LA CHARNIÈRE.

Option A :

Balustrade à poteau carré (perçage non requis)

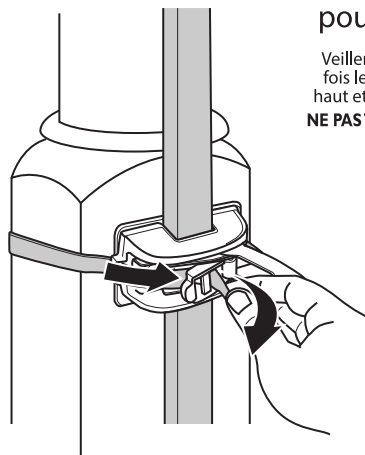
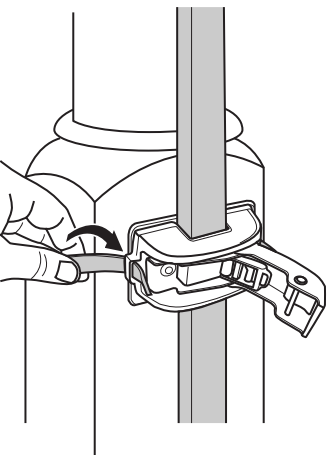
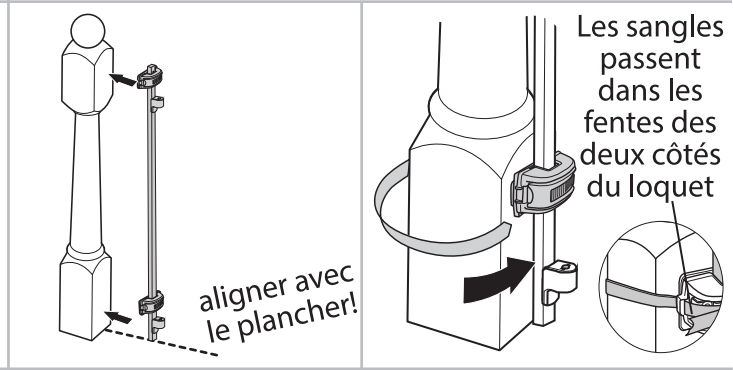
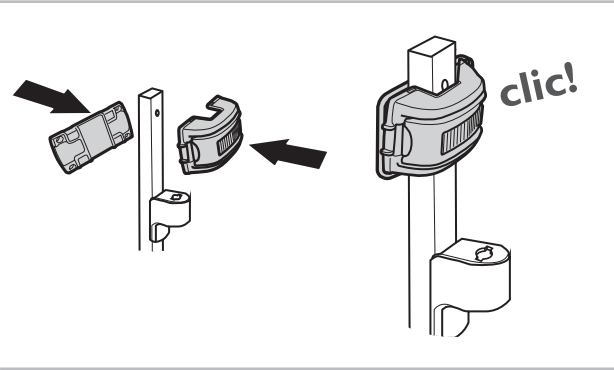
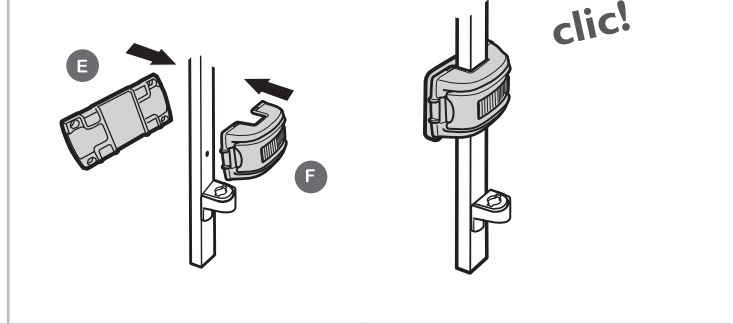
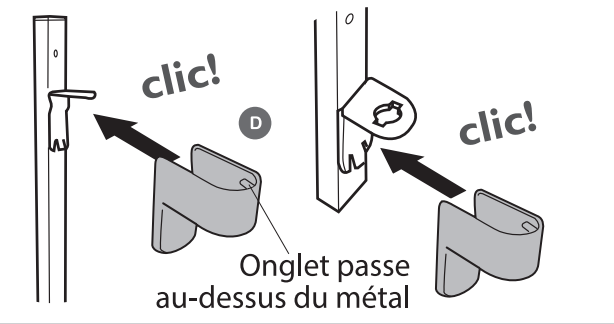
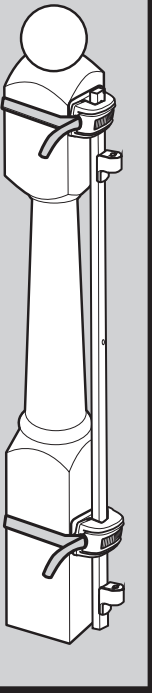

pour serrer
Veiller à serrer à la fois le support du haut et celui du bas!
NE PASTROP SERRER!

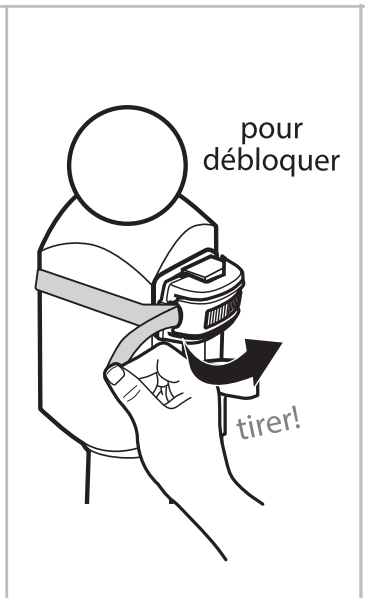
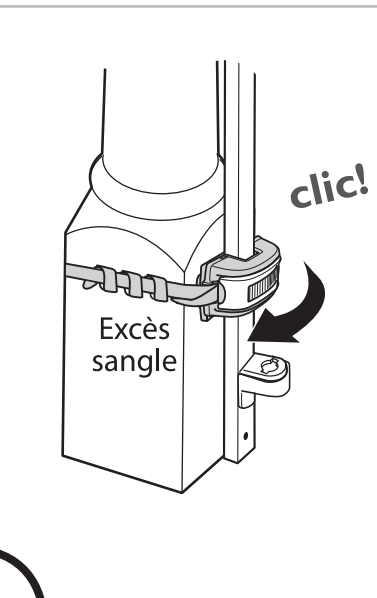
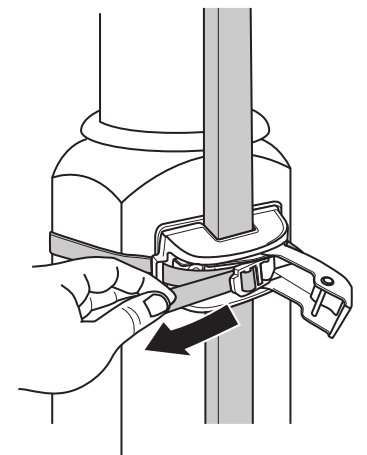
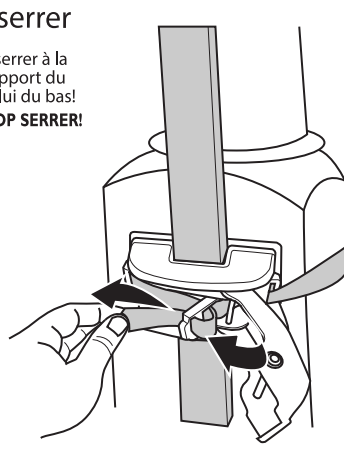

REMARQUE IMPORTANTE :

Des coussinets en mousse supplémentaires sont fournis pour coller à l'assemblage de la charnière en métal afin de protéger le bois de la balustrade. Peler et coller à l'arrière de l'assemblage de la charnière en métal avant de poser celui-ci sur la balustrade.

Le coussinet permet de bien positionner l'assemblage de la charnière en métal afin qu'il repose sur une surface plane.

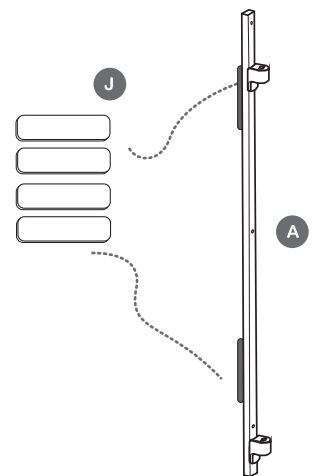

1. Montage de la charnière

Option B :

Montage mural

mur en bois !

ou

panneau mural !

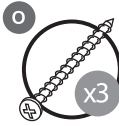

Percer un trou au préalable avec une mèche de 3,2 mm (1/8 po).

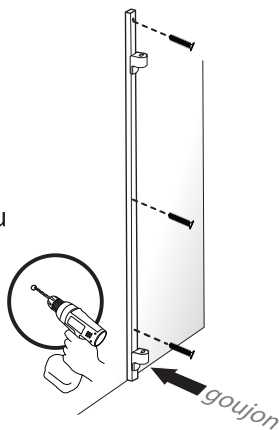

Percer un trou au préalable avec une mèche de 5,5 mm (7/32 po). Se servir des trous existants dans le montant de la balustrade comme guide. Insérer les ancrages muraux dans le trou à l'aide d'un marteau, tapoter légèrement l'extrémité jusqu'à ce que l'ancrage mural soit au même niveau que le mur.

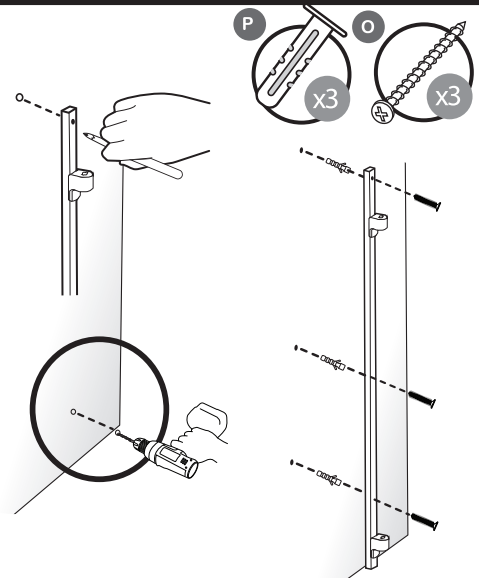

mur en bois avec plinthe !

ou

panneau mural avec plinthe !

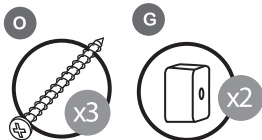

IMPORTANT:

S'il y a une plinthe, utiliser une entretoise. S'il n'y a pas de plinthe, fixer directement au mur.

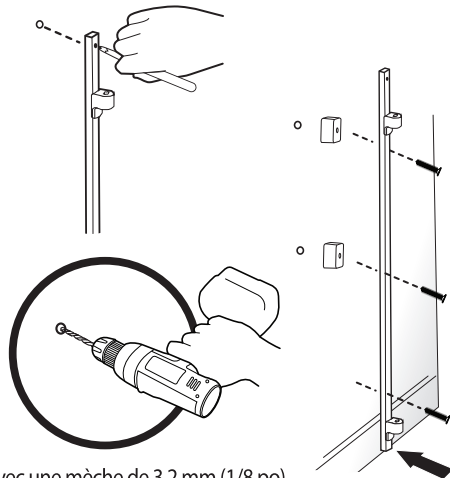

Percer un trou au préalable avec une mèche de 3,2 mm (1/8 po).

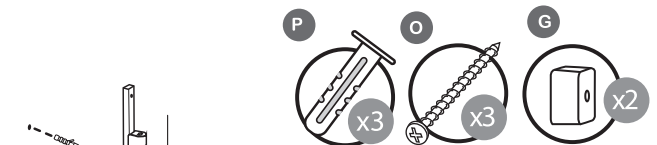

IMPORTANT:

S'il y a une plinthe, utiliser une entretoise. S'il n'y a pas de plinthe, fixer directement au mur.

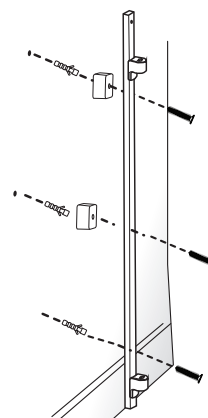

2. Montage de la barrière - Mur

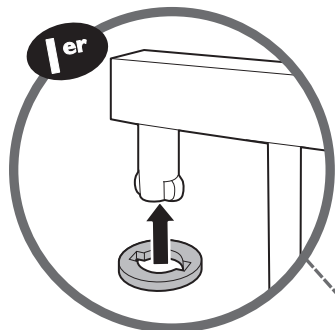

Ajouter les rondelles en plastique (pièce Q) aux boulons des charnières supérieures et inférieures.

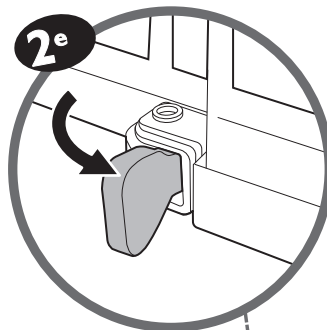

IMPORTANT:

Au sommet du palier, installer la barrière à un minimum de 8 à 15 cm (3 à 6 po) de la marche supérieure.

Déverrouiller les 4 serrures batteuses de la barrière.

IMPORTANT:

La barrière ne doit jamais s'ouvrir dans la direction des escaliers. Le levier du loquet empêchera la barrière de battre dans les deux sens.

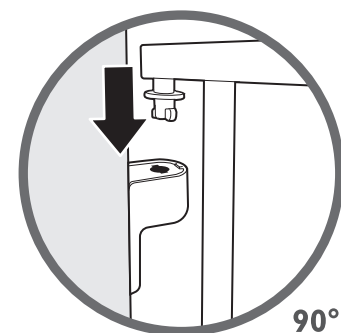

Positionner la barrière à 90° par rapport aux charnières (position ouverte), puis baisser la barrière lentement dans les ouvertures des charnières.

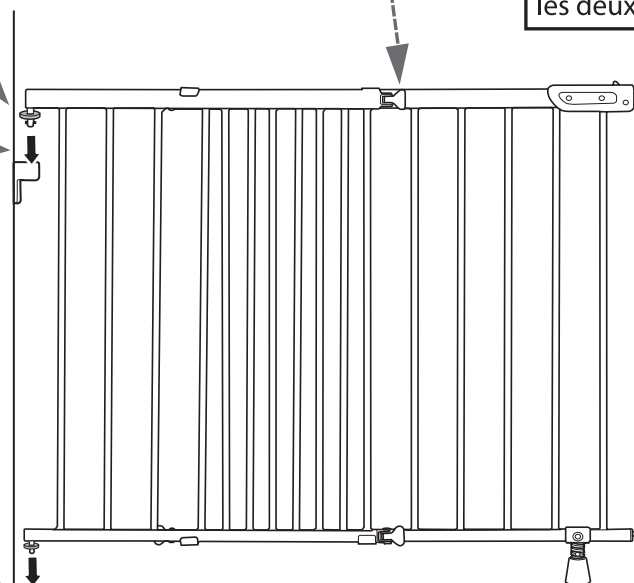
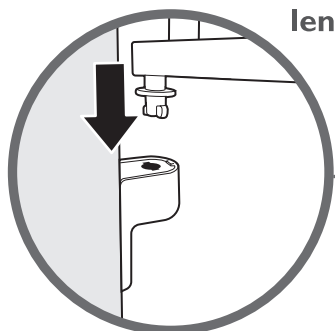

Montage du pied de support :

REMARQUE IMPORTANTE :

Ajuster le pied de support afin qu'il ne touche le sol que légèrement une fois la barrière fermée.

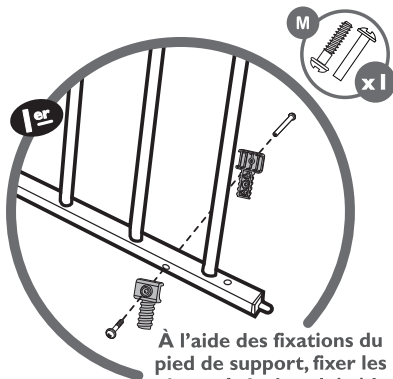

À l'aide des fixations du pied de support, fixer les deux côtés de celui-ci à la base de la barrière.

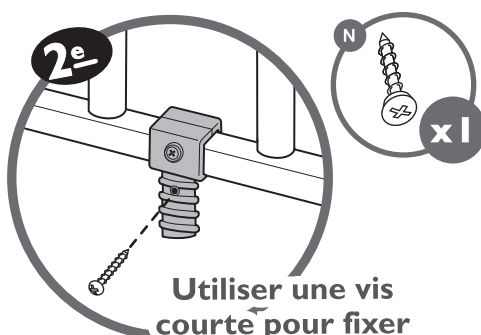

Utiliser une vis courte pour fixer la partie inférieure du pied de support.

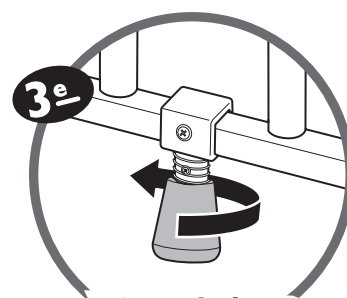

Visser la base du pied de support.

2. Montage de la barrière - Balustrade

IMPORTANT:

Au sommet du palier, installer la barrière à un minimum de 8 à 15 cm (3 à 6 po) de la marche supérieure.

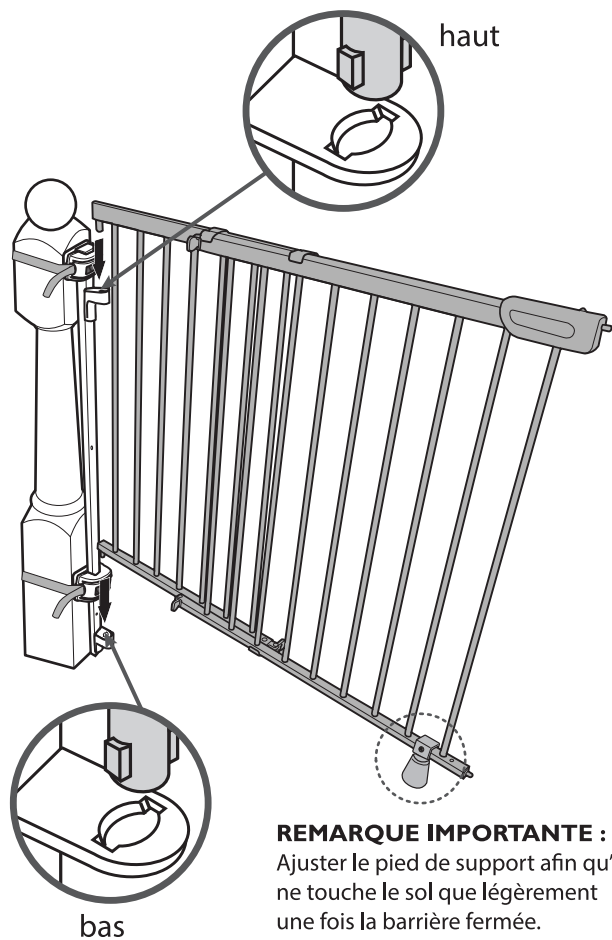

REMARQUE IMPORTANTE :
Ajuster le pied de support afin qu'il ne touche le sol que légèrement une fois la barrière fermée.

IMPORTANT:

La barrière ne doit jamais s'ouvrir dans la direction des escaliers. Le levier du loquet empêchera la barrière de battre dans les deux sens.

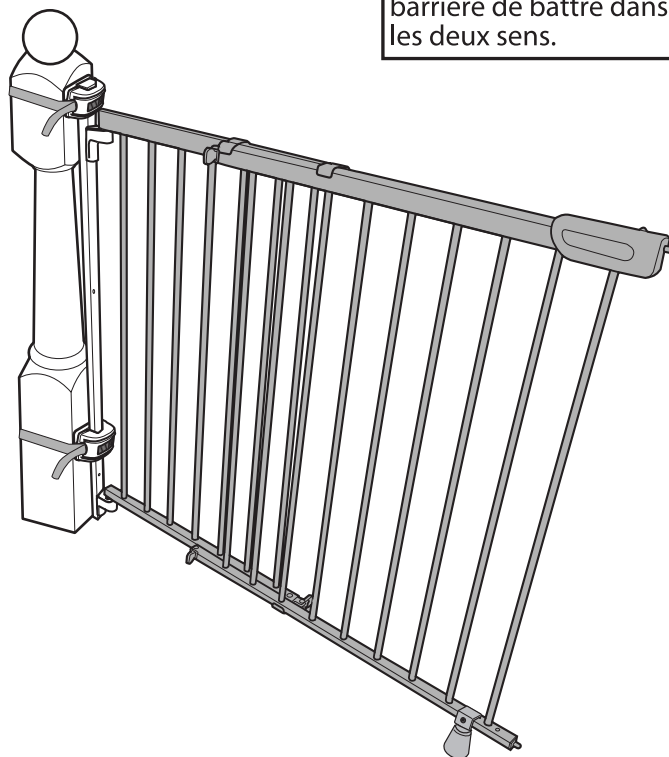

3. Montage du loquet

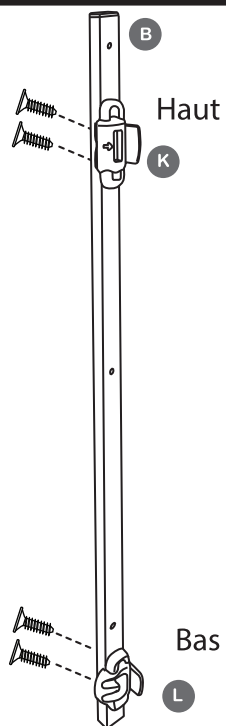
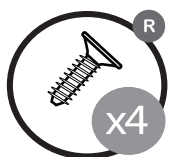

4. Montage du loquet

Balustrade

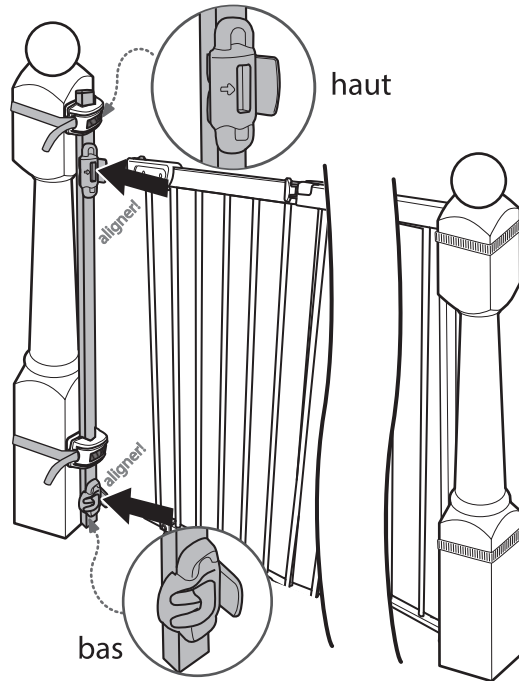
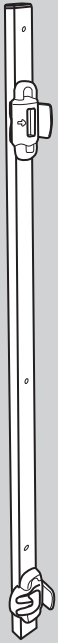

Le montage du loquet est identique au montage de la charnière. Choisir l'option la plus adaptée selon le cas.

Balustrade à poteau carré

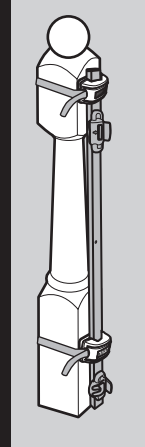

Répéter les étapes décrites dans l'option A

Fixation murale

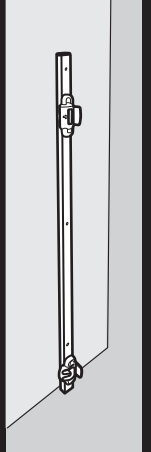

Répéter les étapes décrites dans l'option B

Balustrade jusqu'au mur

Il faut prévoir un espace de 1,6 mm (1/16 po) entre la barrière et le mentonnet du loquet inférieur.

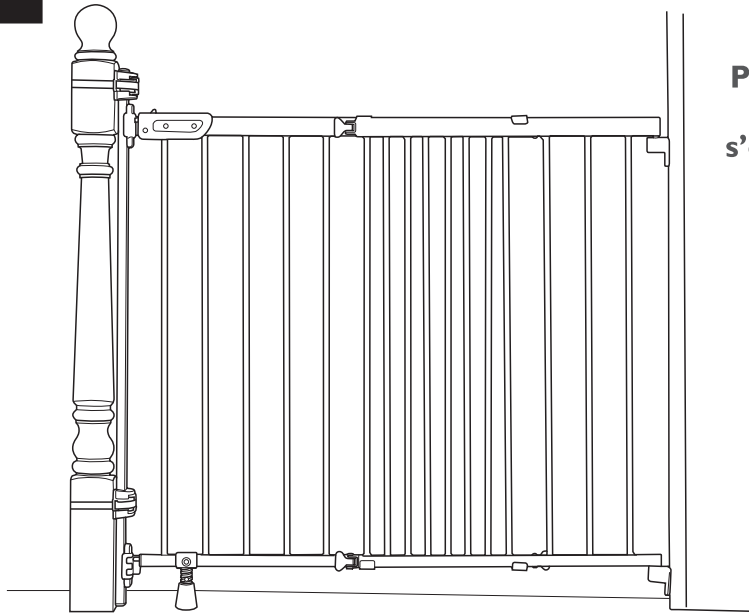
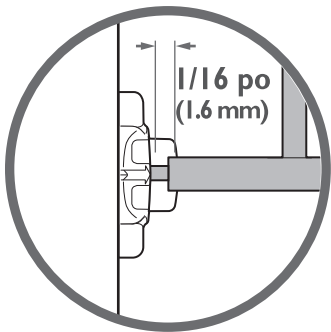

Pousser la barrière jusqu'à ce que la poignée s'enclenche et se verrouille dans le mentonnet du loquet supérieur et inférieur.

Mode d'emploi

FERMETURE DE LA BARRIÈRE :

Pousser la barrière jusqu'à ce que la poignée s'enclenche et se verrouille dans le mentonnet du loquet supérieur et inférieur.

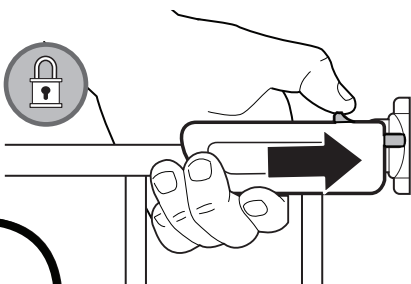

OUVERTURE DE LA BARRIÈRE :

Tirer sur le pavé avec le pouce, puis soulever et ouvrir la barrière.

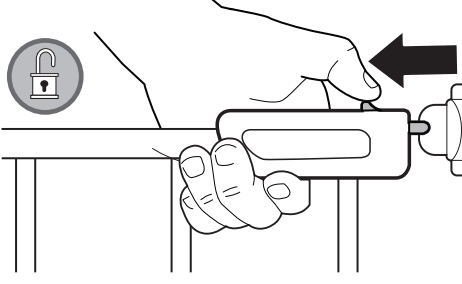

RETRAIT DE LA BARRIÈRE :

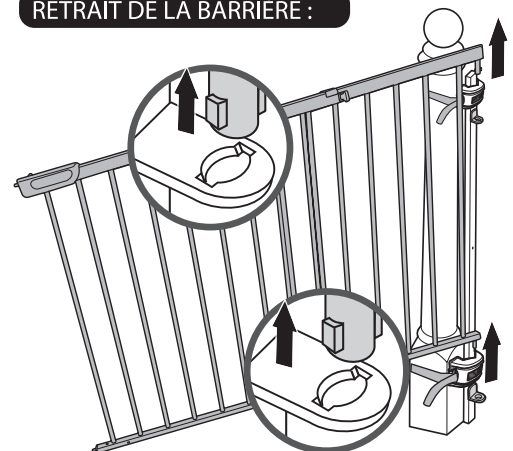

Por favor, lea atentamente las siguientes instrucciones y advertencias. Guarde este manual de instrucciones para referencia futura.

Para obtener asistencia técnica, póngase en contacto con nosotros por el **(401) 671-6578** o **www.summerbyingenuity.com**.

Herramientas necesarias: Destornillador de estrella y taladro (no incluidos). Para uso con niños de 6 a 24 meses. Requiere el montaje hecho por un adulto. Mantenga las piezas pequeñas fuera del alcance de los niños.

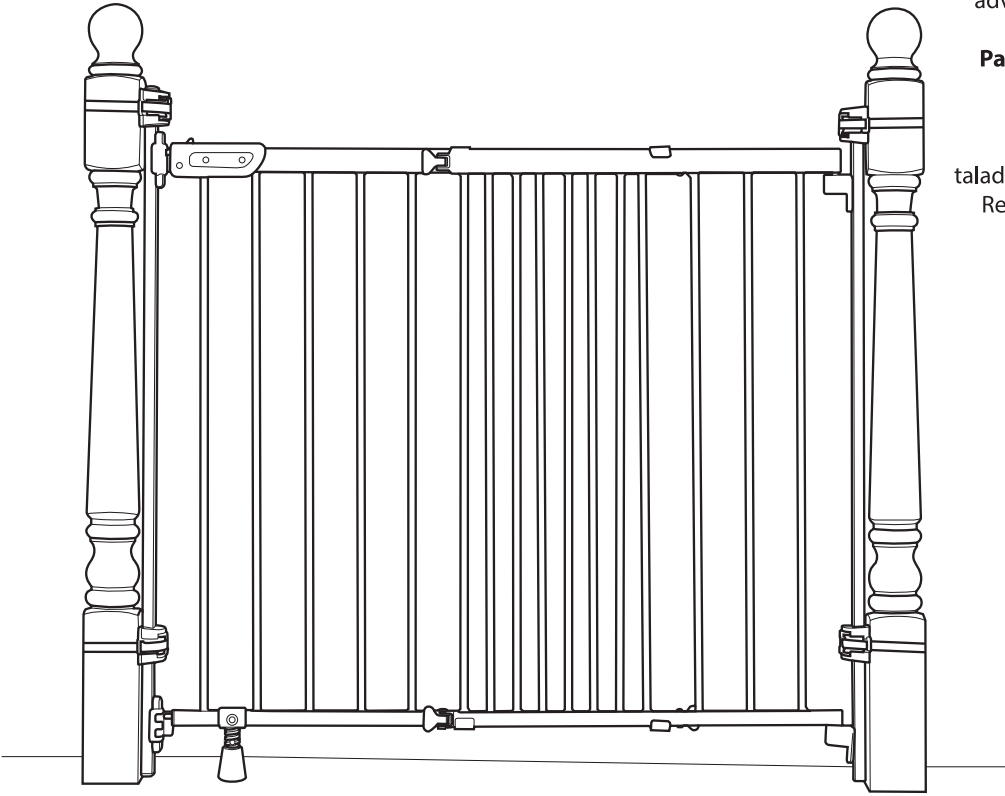

⚠️ ADVERTENCIA

Se han producido muertes o lesiones graves en niños cuando las barreras no se instalan correctamente.

- Instale y use **SIEMPRE** la barrera usando todas las partes necesarias, como se indica.
- Instale según las instrucciones del fabricante.
- **DEJE** de usarla cuando un niño pueda subir o desprender la barrera.
- Use solo con el mecanismo de bloqueo/cierre firmemente acoplado.
- **NUNCA** use la barrera para mantener al niño alejado de la piscina.
- **NUNCA** deje al niño sin supervisión.

- **SIEMPRE** cierre y bloquee la barrera detrás de usted.
- Este producto no evitará necesariamente todos los accidentes. Se requiere la supervisión de un adulto en todo momento.
- No utilice si falta algún componente o está dañada.
- Requiere el montaje hecho por un adulto. Tenga cuidado al desembalar y montar el producto.
- Destinado para niños de 6 a 24 meses.
- No montar en husillos de menos de 5 cm (2 in) de diámetro.
- Compruebe diariamente que los soportes de los balaustres están bien sujetos y que la barrera está bien anclada a los balaustres y/o a la pared.
- **PELIGRO DE CAÍDA:** **NUNCA** permita que un niño se acerque a la puerta hasta que esté cerrada y asegurada.

⚠️ PRECAUCIÓN: MANTENGA LAS PIEZAS PEQUEÑAS FUERA DEL ALCANCE DE LOS NIÑOS.

MANUFACTURED FOR • FABRIQUÉ POUR **kids2™ Kids II®** ©2023 KIDS2, INC. www.kids2.com/help

KIDS2, INC. ATLANTA, GA USA 30305 • 1-800-230-8190

IMPORTED BY • IMPORTÉ PAR

SUMMER INFANT (USA) INC. 1275 PARK EAST DRIVE, WOONSOCKET, RI 02895 USA • 1-401-671-6551

KIDS2 CANADA CO. PO BOX 54059, RPA LAWRENCE PLAZA, TORONTO, ON. M6A 3B7

KIDS2 AUSTRALIA PTY LIMITED CASTLE HILL, NSW AUSTRALIA 2154 • (02) 9894-1855

KIDS2 JAPAN K.K. c/o ARK Outsourcing KK 4-3-5-704, Ebisu, Shibuya-ku, Tokyo, Japan 150-0013 • (03) 5322-6081

KIDS2 UK LTD. GROUND FLOOR, SUITE A1A, BREAKSPEAR PARK, BREAKSPEAR WAY, HEMEL HEMPSTEAD, HP2 4TZ • +44 01582 816 080

KIDS2 EUROPE BV 5 KEIZERS, KEIZERSGRACHT 287, 1016 ED AMSTERDAM, NETHERLANDS • +31 20 2410934

KIDS2 US MÉXICO S.A. DE C.V. • (55) 5292-8488

MADE IN CHINA • HECHO EN CHINA • FABRIQUÉ EN CHINE

Los colores y estilos pueden variar.

HECHO EN CHINA.

componentes:

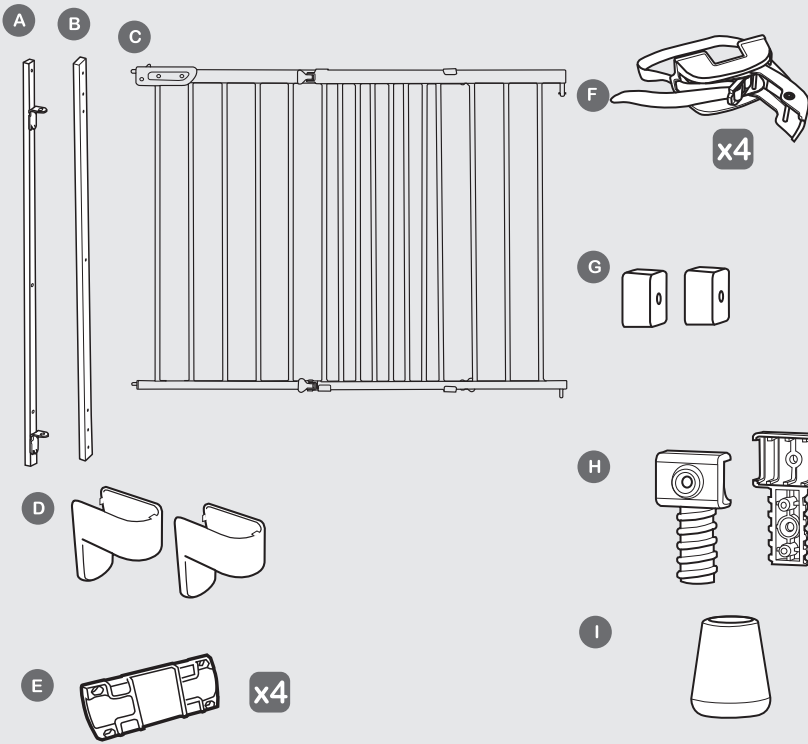

Herramientas necesarias (no incluidas)

Destornillador de estrella

SÓLO LA OPCIÓN DE MONTAJE EN PARED:

Taladro con broca de 5,5 mm (7/32 in)

SÓLO LA OPCIÓN DE MONTAJE EN PARED DE MADERA: pretaladre con broca de 3,2 mm (1/8 in)

x4

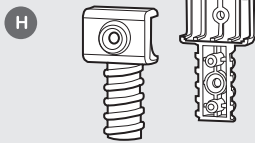
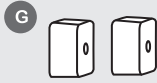

Cierre superior



Cierre inferior

- A Montaje izquierdo de la barrera
- B Montaje derecho de la barrera
- C Barrera
- D Tapas de los soportes de las bisagras (2)
- E Placa del balaustre/almohadilla de espuma (4)
- F Base de la correa del cierre del balaustre (4)
- G Espaciador de balaustre (2)

- H Componentes del tornillo del pie de apoyo
- I Pie de apoyo
- J Almohadillas de espuma adicionales (4)
- K Cierre superior
- L Enganche del cierre inferior
- M Tornillo del pie de apoyo
- N Tornillo del pie de apoyo inferior
- O Tornillos de pared (6)
- P Anclajes de pared (6)
- Q Arandelas (2)
- R Tornillos de fijación del cierre superior/inferior (4)

herrajes

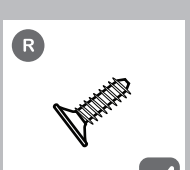
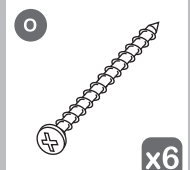
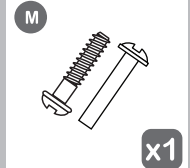

Montaje de la bisagra

La barrera se adapta a aberturas de 79 a 117 cm (31 a 46 in) !

IMPORTANTE: Coloque la barrera en el rellano superior a una distancia de 7.62 cm (3 in) del borde de la escalera superior o lo más lejos que pueda colocarse en función del tamaño y la ubicación de sus balaustres.

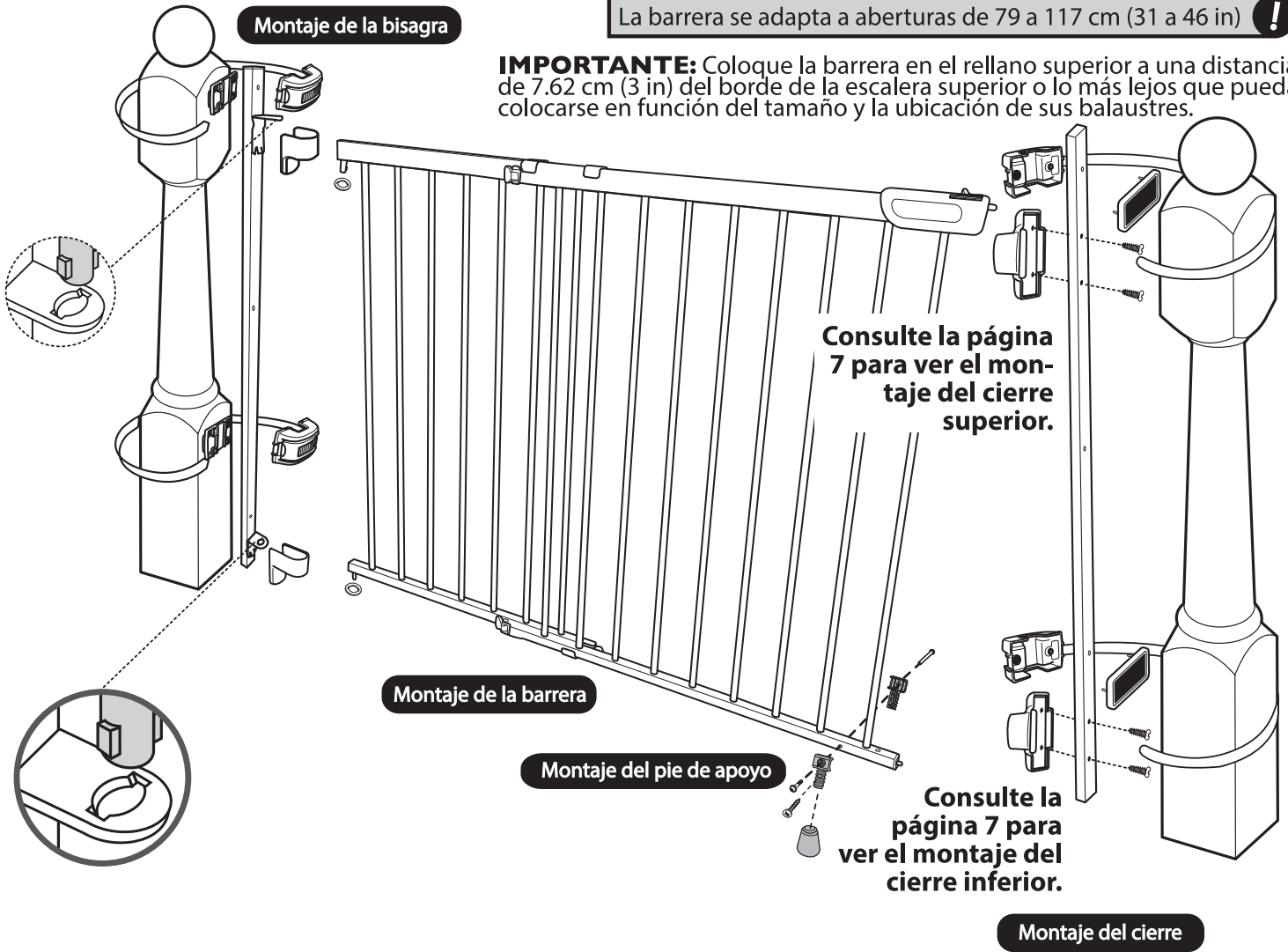

mantenimiento:

- Compruebe toda la tornillería para asegurarse de que la barrera está bien colocada.
- No utilice la barrera si alguno de los componentes está dañado o falta.
- Limpie la superficie con una esponja o paño húmedo, utilizando un detergente suave y agua tibia. Secar con una toalla.

1. Montaje de la bisagra

ELIJA CUÁL DE LAS DOS OPCIONES DE LA SECCIÓN DE MONTAJE DE BISAGRA SE ADAPTA MEJOR A SUS NECESIDADES.

Opción A:

Balaustre con parte superior cuadrada (no es necesario taladrar)

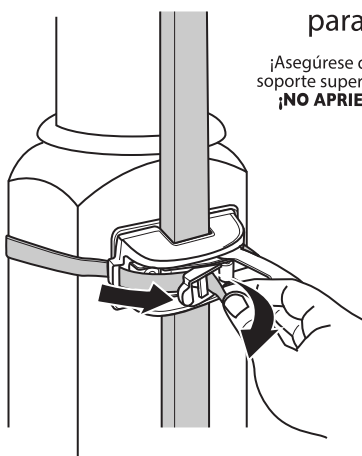
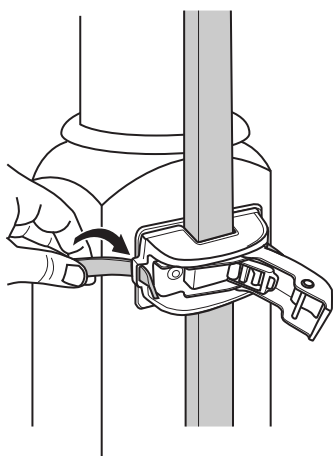
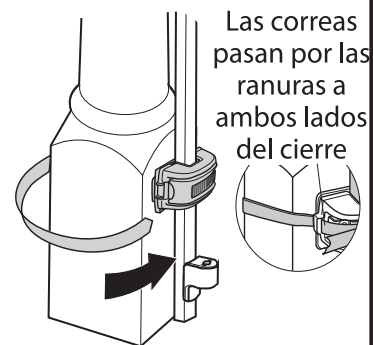
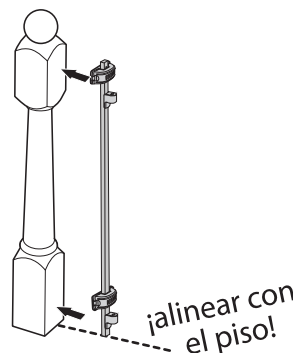
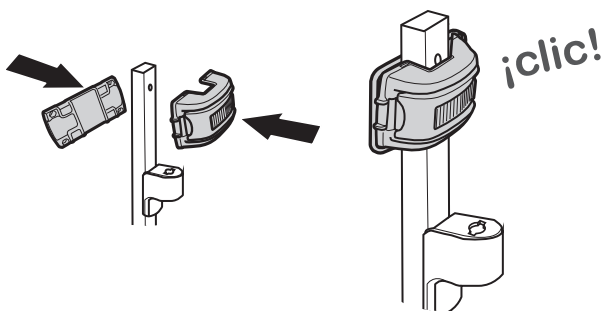
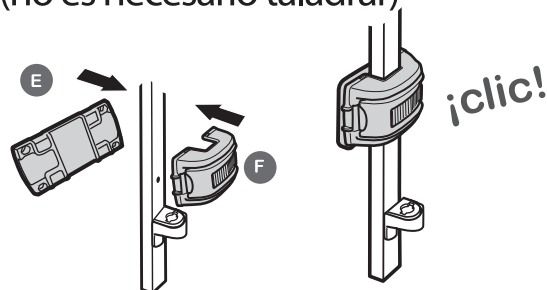
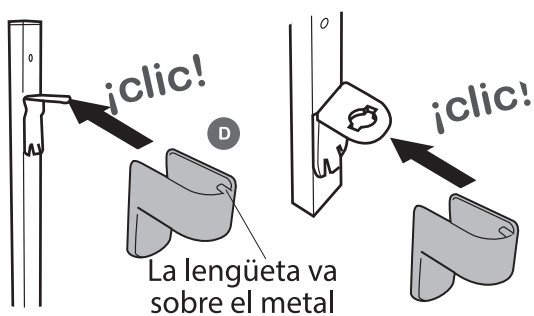
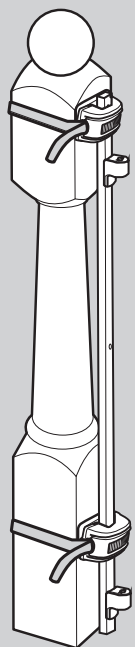

para apretar
¡Asegúrese de apretar tanto el soporte superior como el inferior!
¡NO APRIETE DEMASIADO!

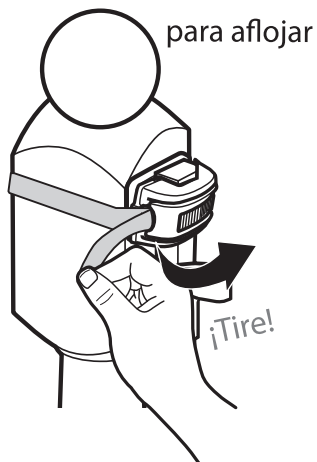
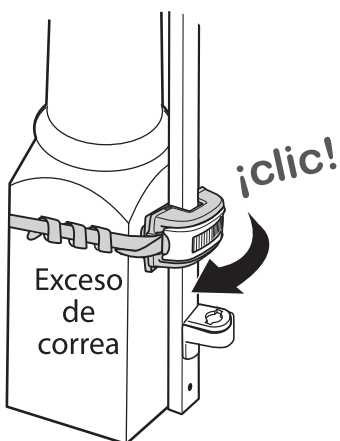
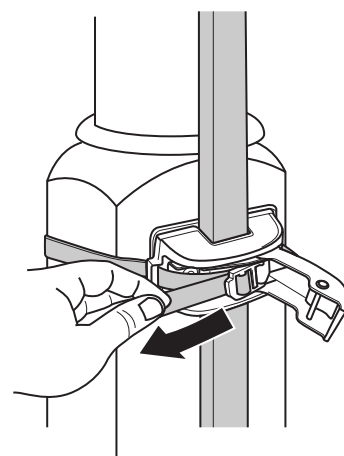
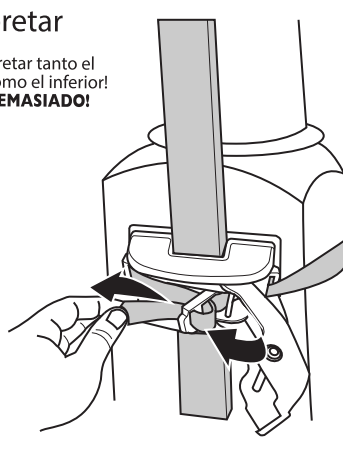

NOTA IMPORTANTE:
se suministran almohadillas de montaje adicionales para pegar al conjunto de bisagra metálica con el fin de proteger la madera de su balaustre. Despegue la película protectora y pégue la parte posterior del conjunto de bisagras metálicas antes de montar en el balaustre.

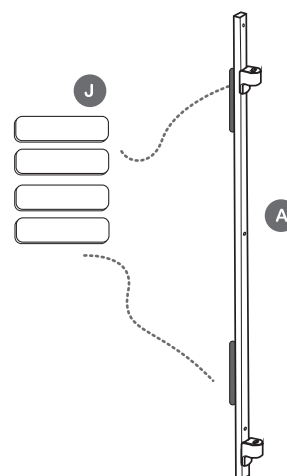

La almohadilla está diseñada para ayudar a colocar el soporte metálico de la bisagra de modo que quede sobre una superficie plana.

1. Montaje de la bisagra

Opción B:

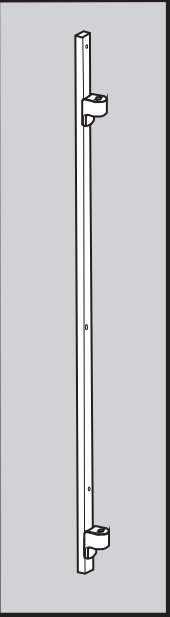

Soporte de pared



Pretaladre un agujero con una broca de 3 mm o 1/8 in.

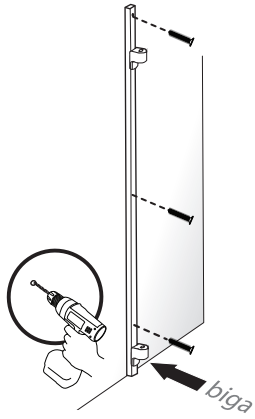

pared de madera !



panel de yeso !

Pretaladre agujeros pilotos con una broca de 5,5 mm (7/32 in). Utilice como guía los agujeros preexistentes en el soporte del balaustre. Inserte los anclajes de pared en el agujero con un martillo, golpee suavemente en el extremo hasta que el anclaje de pared quede a ras con la pared.

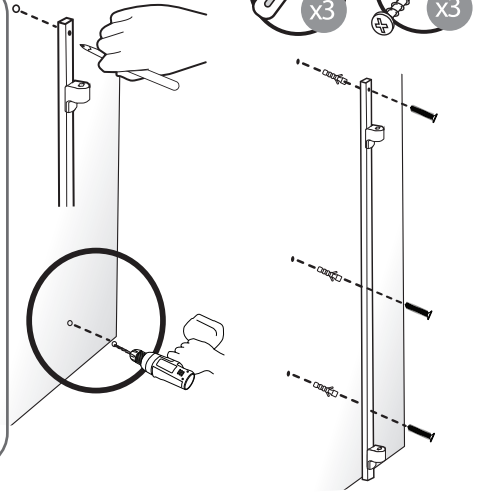

pared de madera con zócalo !



pared de panel de yeso con zócalo !

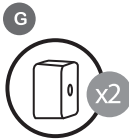
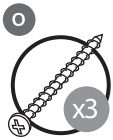

! IMPORTANTE:
si existe el zócalo, utilice el separador. Si no hay zócalo, fíjelo directamente a la pared.

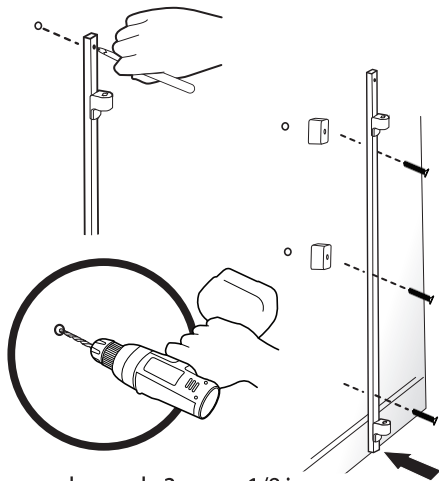

Pretaladre un agujero con una broca de 3 mm o 1/8 in.

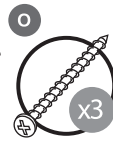

! IMPORTANTE:
si existe el zócalo, utilice el separador. Si no hay zócalo, fíjelo directamente a la pared.

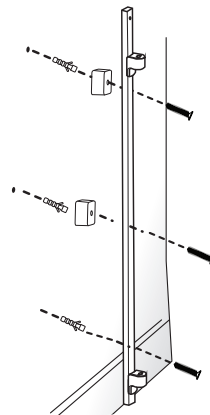

2. Montaje de la barrera - Pared

! IMPORTANTE:
En la parte superior del descanso, coloque la barrera a una distancia mínima de 8 a 15 cm (3 a 6 in) del escalón superior.

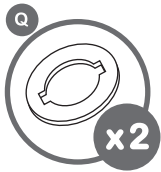

Añada insertos de plástico (pieza Q) a los pernos de las bisagras superior e inferior..

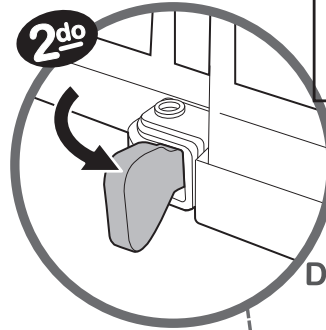
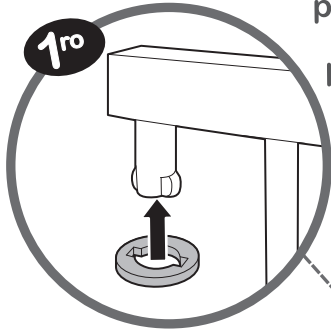

Desbloquee las 4 levas de la barrera.

! IMPORTANTE:
La barrera nunca debe abrirse por encima de las escaleras. El saliente del cierre impedirá que la barrera oscile en ambos sentidos.

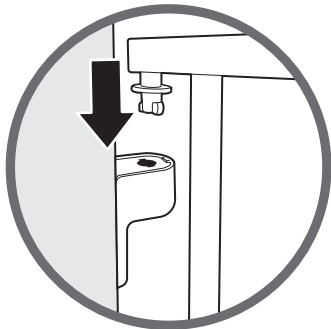

Con la barrera a 90° de las bisagras (posición abierta), baje la barrera hasta las aberturas de las bisagras.

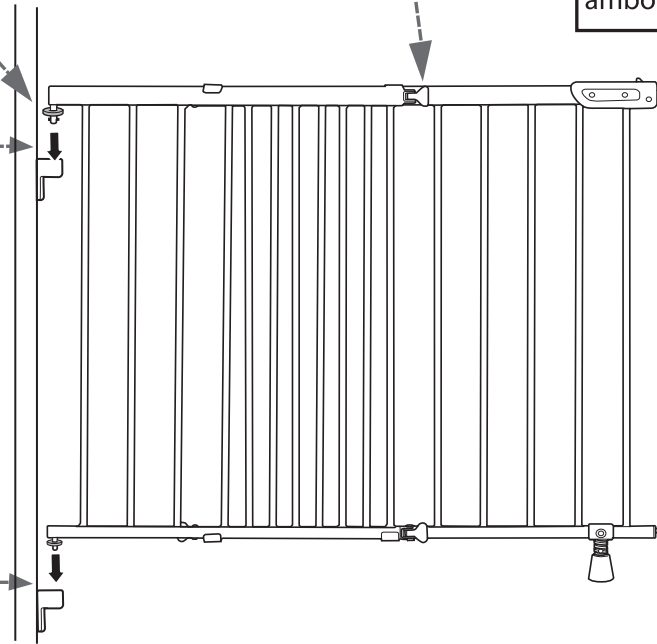
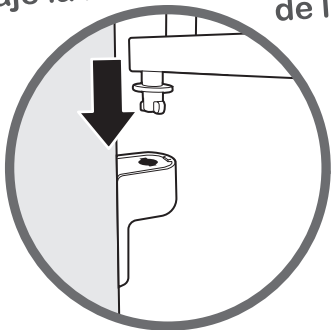

Montaje del pie de apoyo:

NOTA IMPORTANTE:
ajuste el pie para que toque el suelo cuando la barrera esté cerrada.

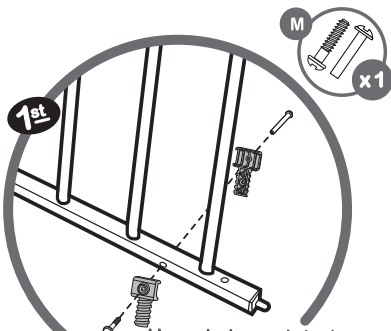

Usando los sujetadores del pie de apoyo, fije ambos lados del Soporte a la base de la barrera..

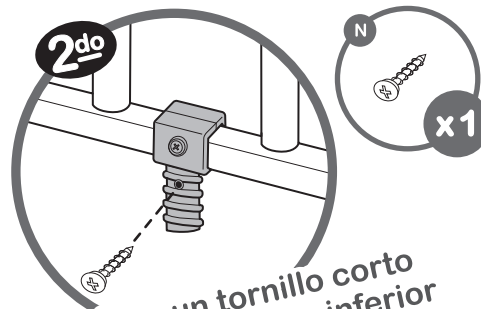

Utilice un tornillo corto para fijar la parte inferior del pie de apoyo.



Tornillo en la base del pie de apoyo.

2. Montaje de la barrera - Balaustre

IMPORTANTE: en la parte superior del descanso, coloque la barrera a una distancia mínima de 8 a 15 cm (3 a 6 in) del escalón superior.

IMPORTANTE: la barrera nunca debe abrirse por encima de las escaleras. El saliente del cierre impedirá que la barrera oscile en ambos sentidos.

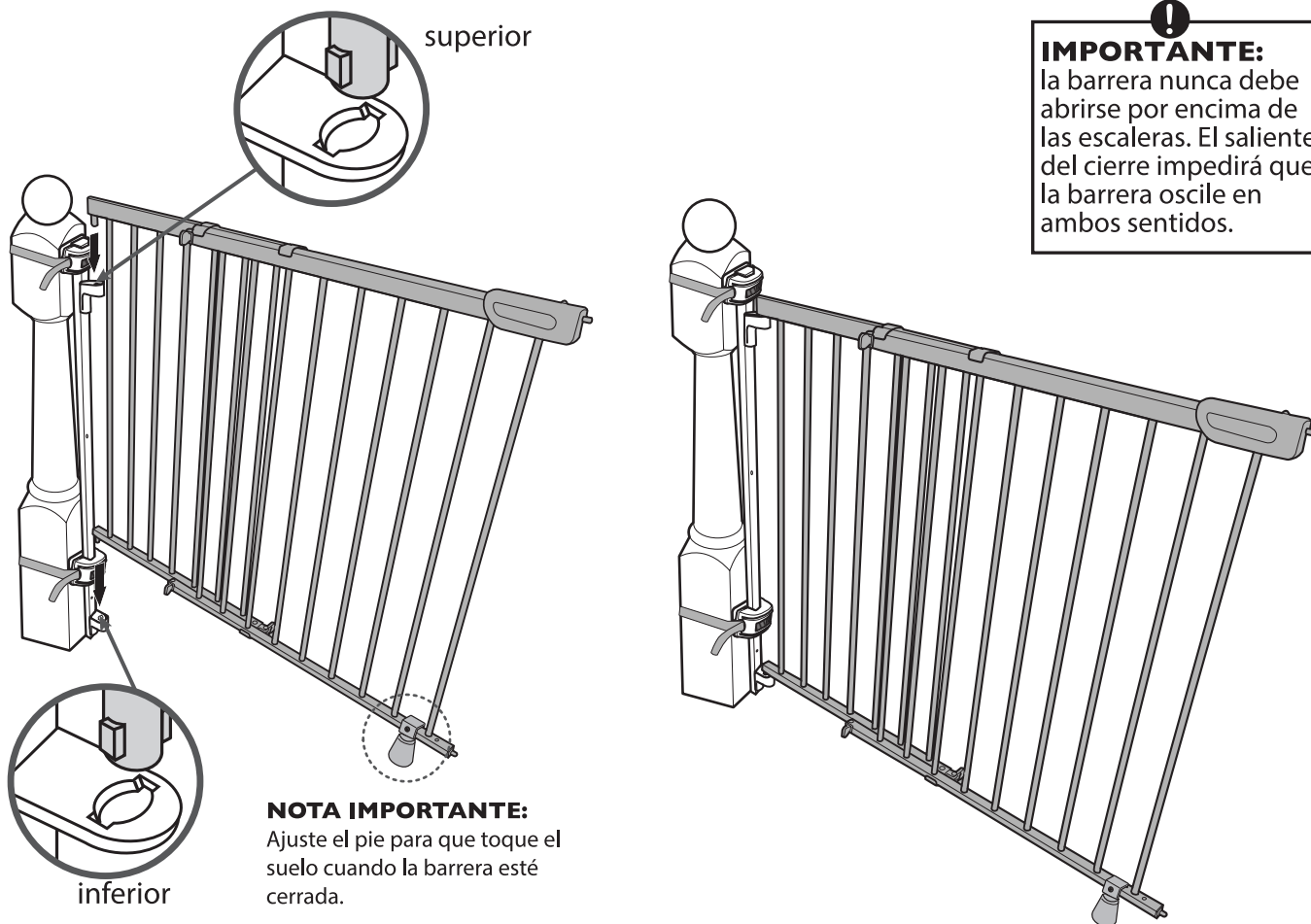

3. Montaje del cierre

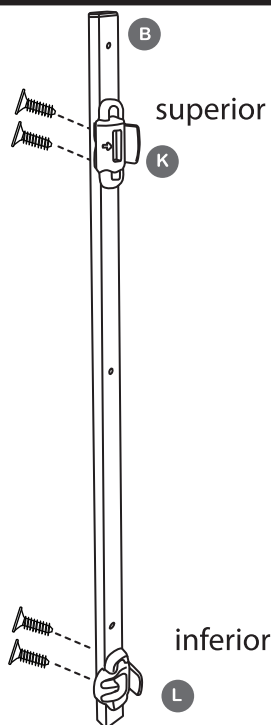
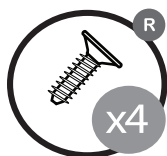

4. Montaje del cierre (continuación)

El ensamblaje del cierre es idéntico al de la bisagra. Elija cuál de las dos opciones se adapta mejor a sus necesidades.

Balaustre

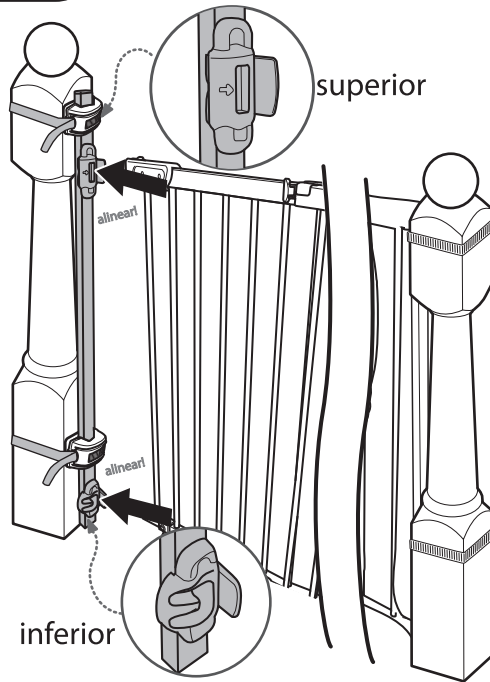

Balaustre con parte superior cuadrada

Montaje en pared

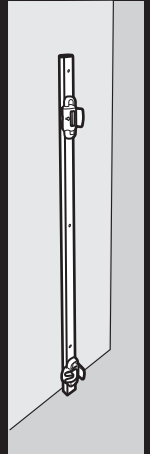
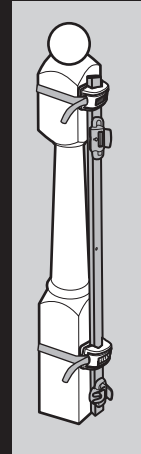

Repita el montaje Opción A

Repita el montaje Opción B

Balaustre a la pared

Debe haber un espacio de 1,6 mm (1/16 in) entre la barrera y el cierre inferior.

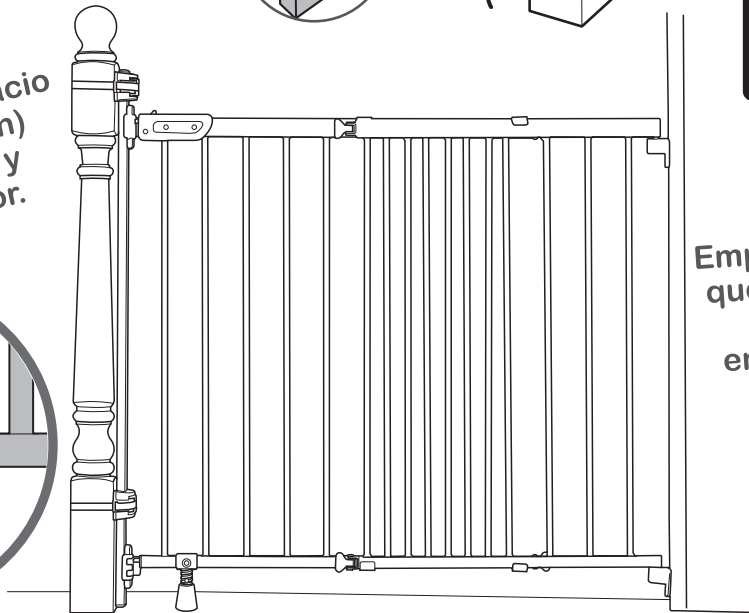
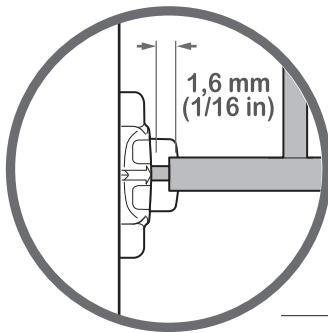

Empuje la barrera hasta que la manilla encaje y se bloquee en los enganches del cierre superior e inferior.

Instrucciones de uso

PARA CERRAR LA BARRERA:

Empuje la barrera hasta que la manilla encaje y se bloquee en los enganches del cierre superior e inferior.

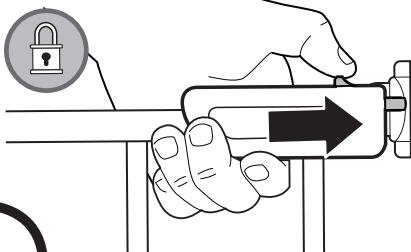

PARA ABRIR LA BARRERA:

Tire hacia atrás de la almohadilla y levante y abra la barrera.

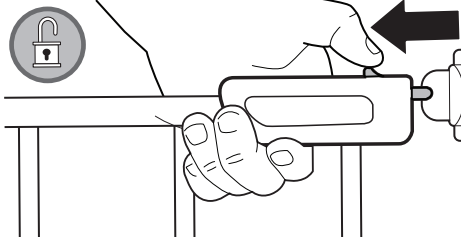

PARA RETIRAR LA BARRERA:

