



20356
20357

**GROW TOGETHER™ POCKET ADJUSTABLE
DESK WITH HUTCH AND CHAIR**
**PETIT BUREAU RÉGLABLE GROW TOGETHER™
AVEC SECRÉTAIRE ET CHAISE**
**PUPITRE AJUSTABLE CON CAJONERA Y SILLA
GROW TOGETHER™**



**CALL US OR GO ONLINE
APPELEZ-NOUS OU ALLEZ EN LIGNE
LLÁMENOS O VISITE NUESTRO SITIO WEB**

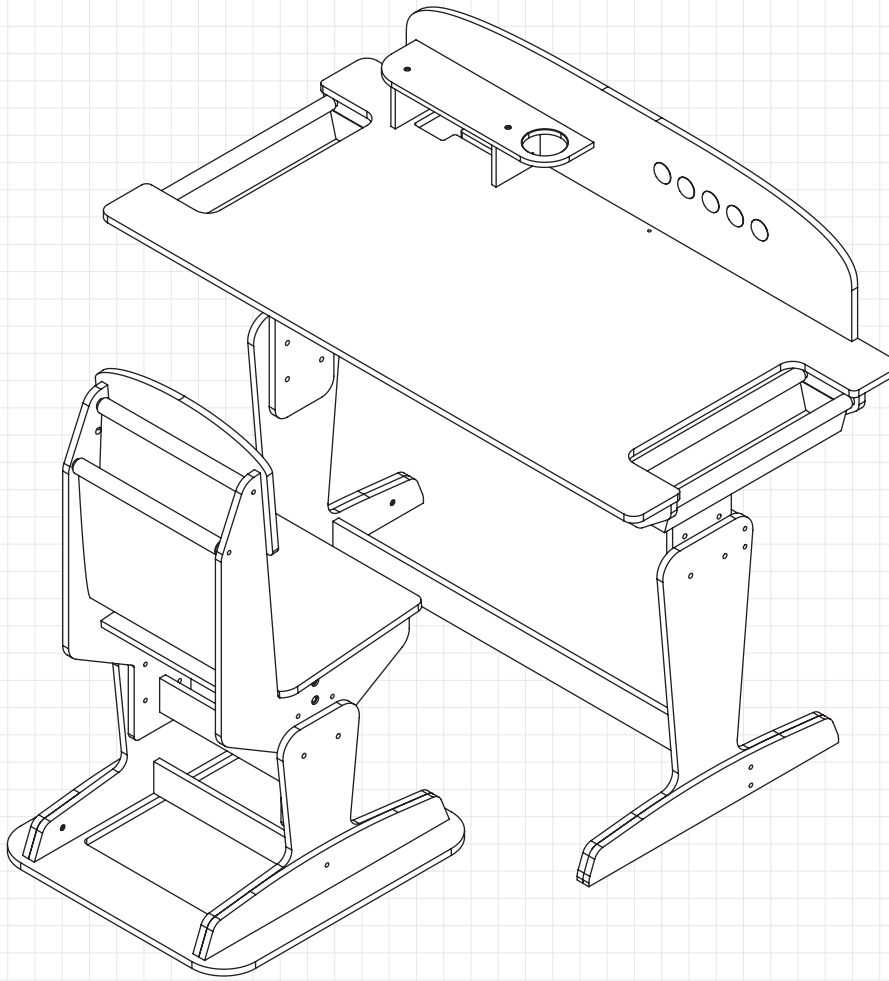

REV 06/16/2022

ASSEMBLY INSTRUCTIONS / INSTRUCTIONS D'ASSEMBLAGE / INSTRUCCIONES DE MONTAJE

**FOR 24/7 ONLINE PARTS REPLACEMENT / POUR LE
REPLACEMENT 24/7 DES PIÈCES EN LIGNE / PARA SOLICITUDES
ONLINE DE PIEZAS DE REPUESTO DE MANERA ININTERRUMPIDA**

parts.kidkraft.com

KidKraft, Inc.
4630 Olin Road
Dallas, Texas 75244
USA

customerservice@kidkraft.com

1.800.933.0771
972.385.0100

parts.kidkraft.eu

KidKraft Netherlands BV
Olympisch Stadion 8
1076 DE Amsterdam
The Netherlands

europecustomerservice@kidkraft.com

+31 20 305 8620
M-F from 09:00 to 17:30 (GMT+1)

BATCH CODE / CODE DE LOT / CÓDIGO DE LOTE

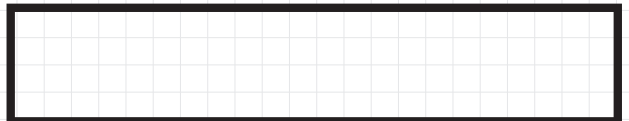

We do our very best to ensure accuracy in every order, but occasionally we miss something. That's why our warranty covers every single part of your new product for 90 days after purchase.

Nous faisons de notre mieux pour assurer l'exactitude dans chaque commande, mais parfois nous manquons quelque chose. C'est pourquoi notre garantie couvre chaque partie de votre nouveau produit pendant 90 jours après l'achat.

Hacemos nuestro mejor esfuerzo para asegurar la precisión en cada orden, pero a veces se nos olvida algo. Por este motivo, nuestra garantía cubre cada parte de su nuevo producto por los próximos 90 días después de su compra.

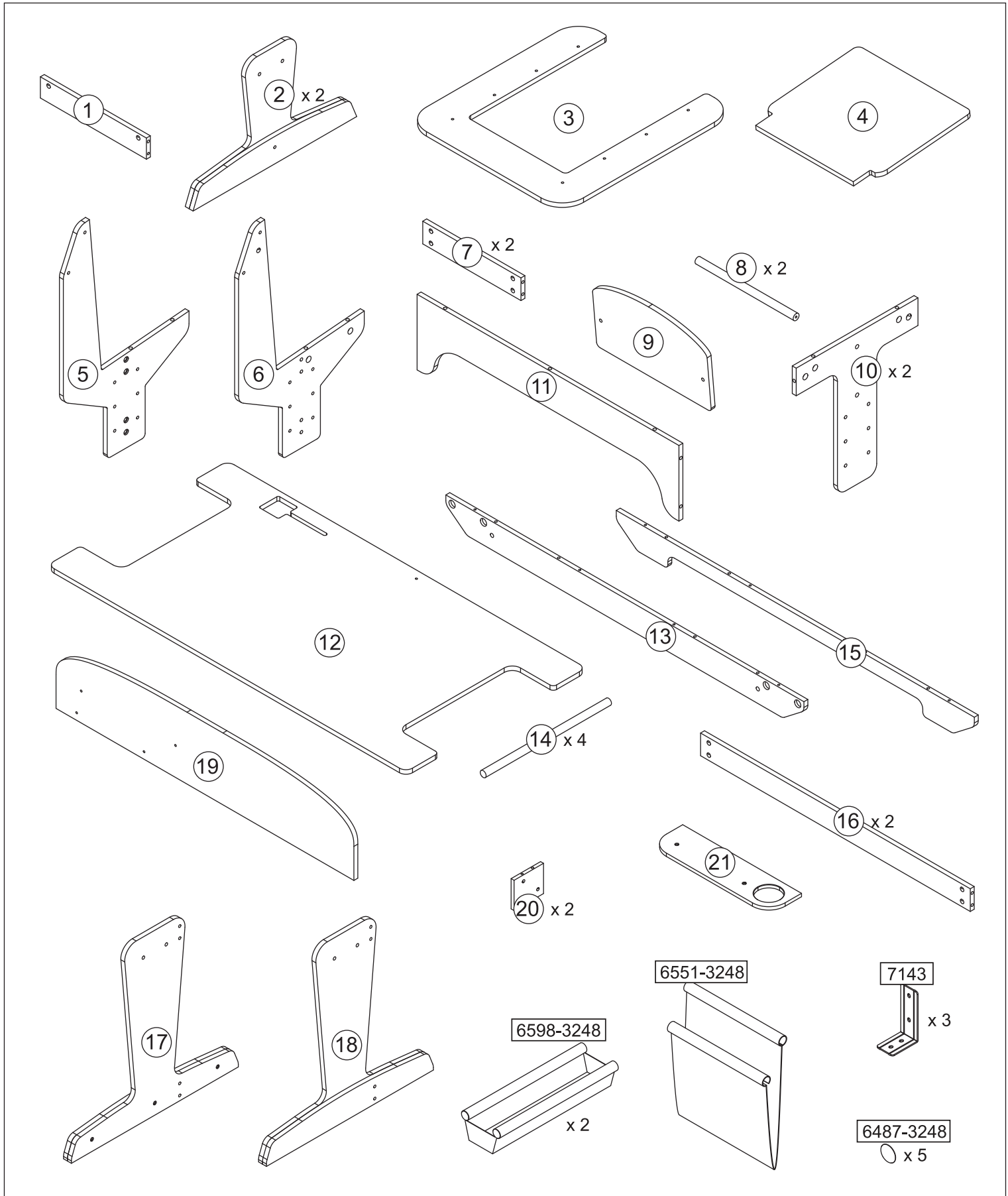









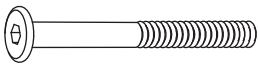
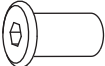







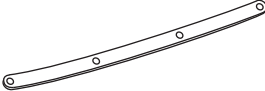

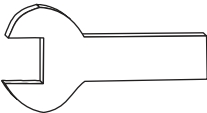
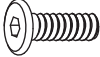

Parts and Hardware
Pièces et matériel
Partes y Piezas Para Instalación
Teile und Befestigungsmaterial
Parti e componenti meccanici



parts.kidkraft.com

customerservice@kidkraft.com
 1.800.933.0771
 972.385.0100

A	x 6	G	x 8	M	x 19	S	x 1
							
63 mm		18 mm					
B	x 12	H	x 8	N	x 12	T	x 2
							
50 mm		45 mm					
C	x 2	I	x 2	O	x 1	U	x 1
							
50 mm White / Blanc / Blanco / Weiß / Bianco		32 mm Green / Vert / Verde / Grün / Verde					
D	x 4	J	x 12	P	x 1		x 1
							
38 mm		32 mm					
E	x 12	K	x 20	Q	x 1		x 1
							
12 mm				25 mm			
F	x 8	L	x 19	R	x 1	<p>Tool required: Outils requis : Herramientas necesarias: Benötigtes Werkzeug: Attrezzi necessari:</p>   <p>Phillips® screwdriver Tournevis Phillips® Destornillador Phillips® Kreuzschraubenzieher Cacciavite Phillips®</p>	
							
18 mm				35 mm			

Parts and Hardware
Pièces et matériel
Partes y Piezas Para Instalación
Teile und Befestigungsmaterial
Parti e componenti meccanici

All hardware dimensions are approximate.
Toutes les dimensions du matériel
sont approximatives.
Todas las dimensiones de las herramientas
son aproximaciones.

europcustomerservice@kidkraft.com
+31 20 305 8620
M-F from 09:00 to 17:30 (GMT+1)

parts.kidkraft.eu



1

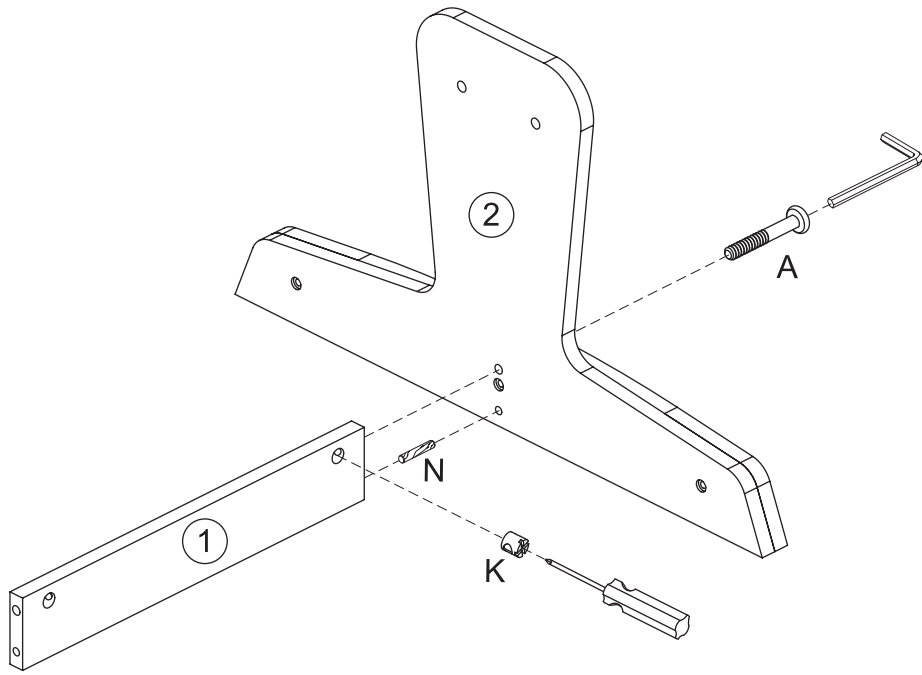

2

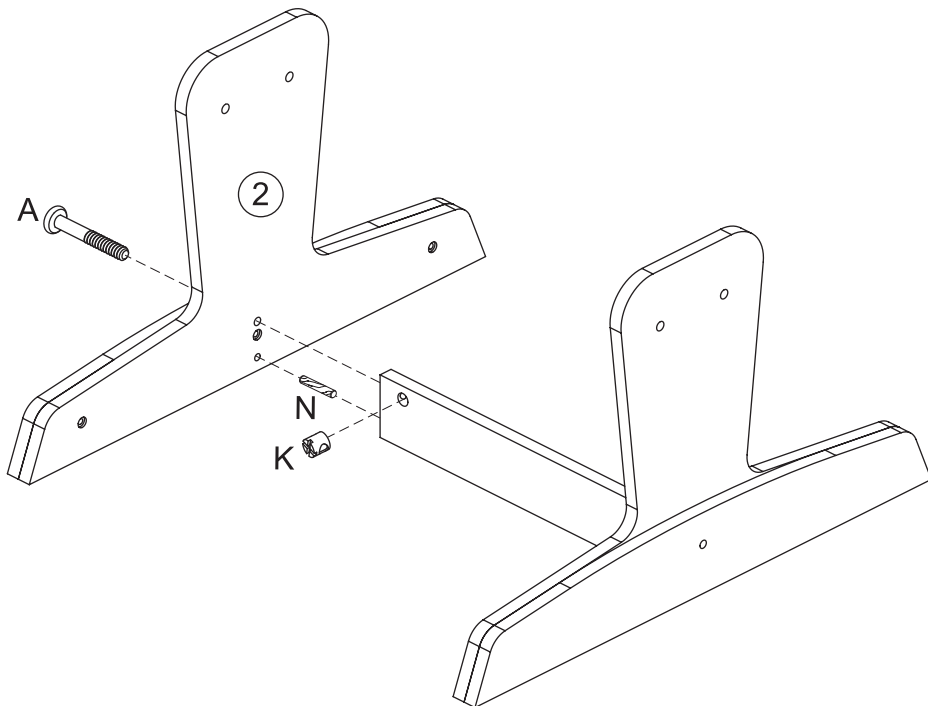

3

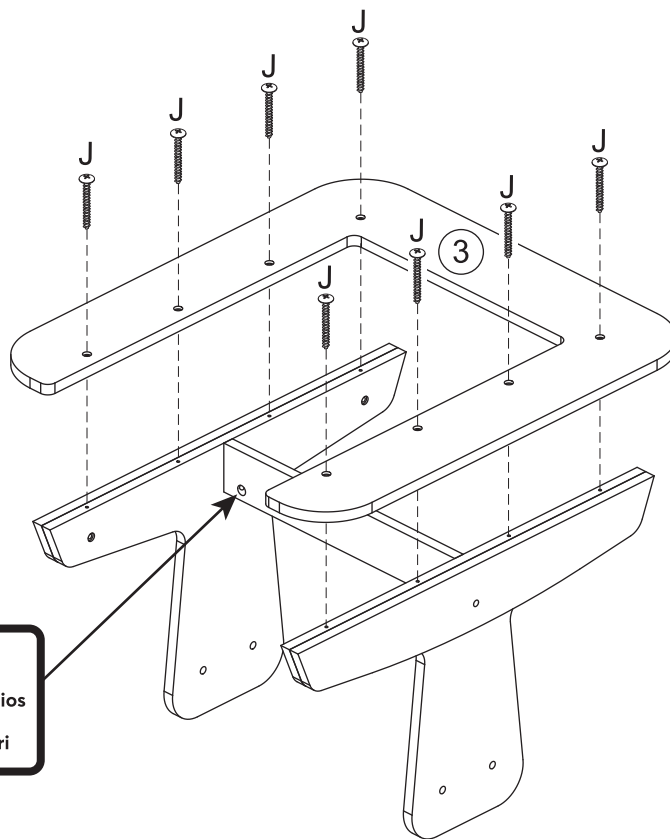

Notice hole orientation
Faites attention à l'orientation des trous
Tenga en cuenta la orientación de los orificios
Ausrichtung der Bohrungen beachten
Prestare attenzione all'orientamento dei fori



4

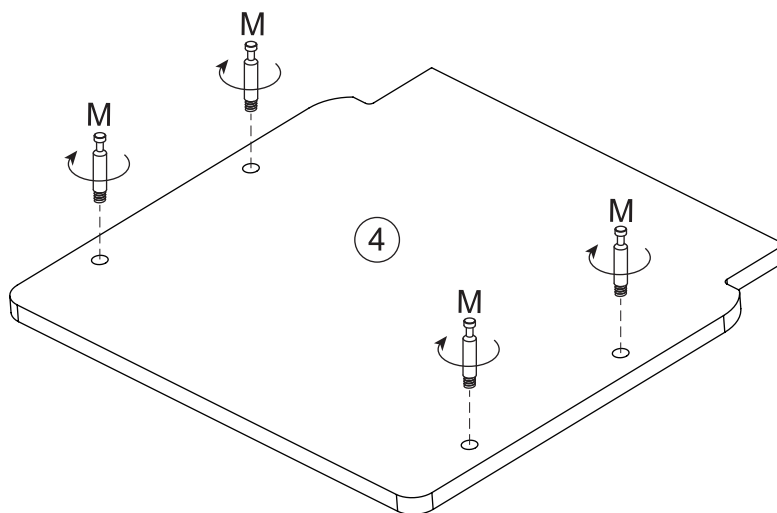

5

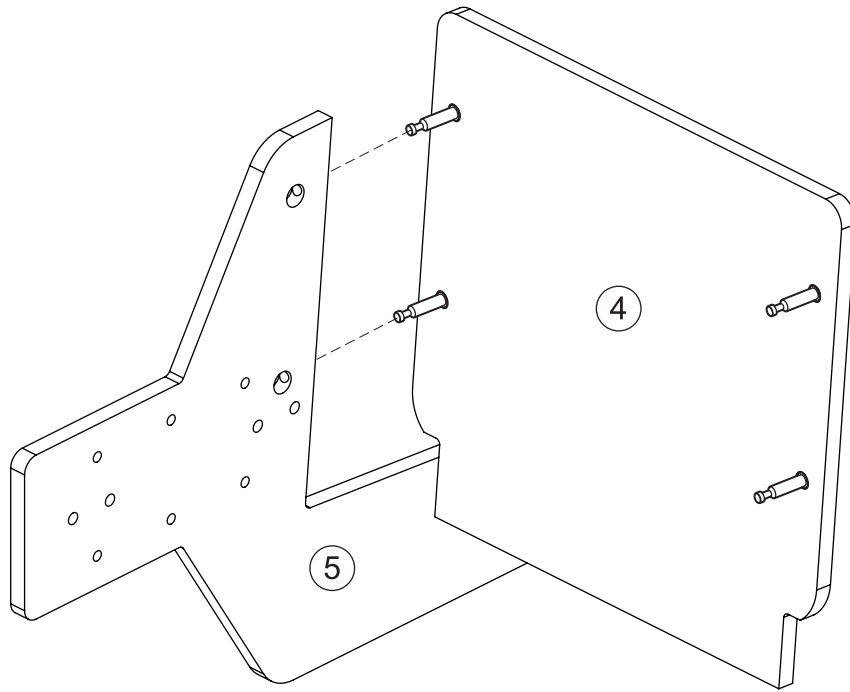

6

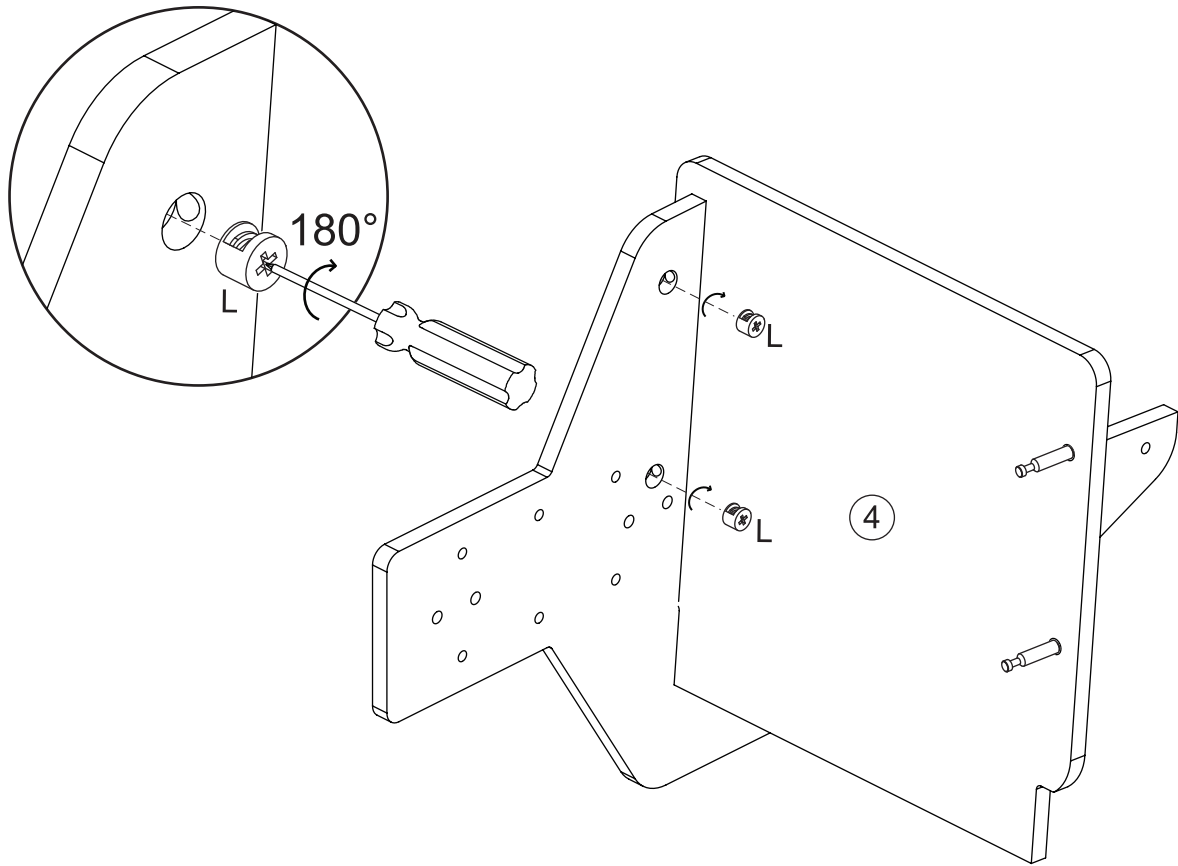

7

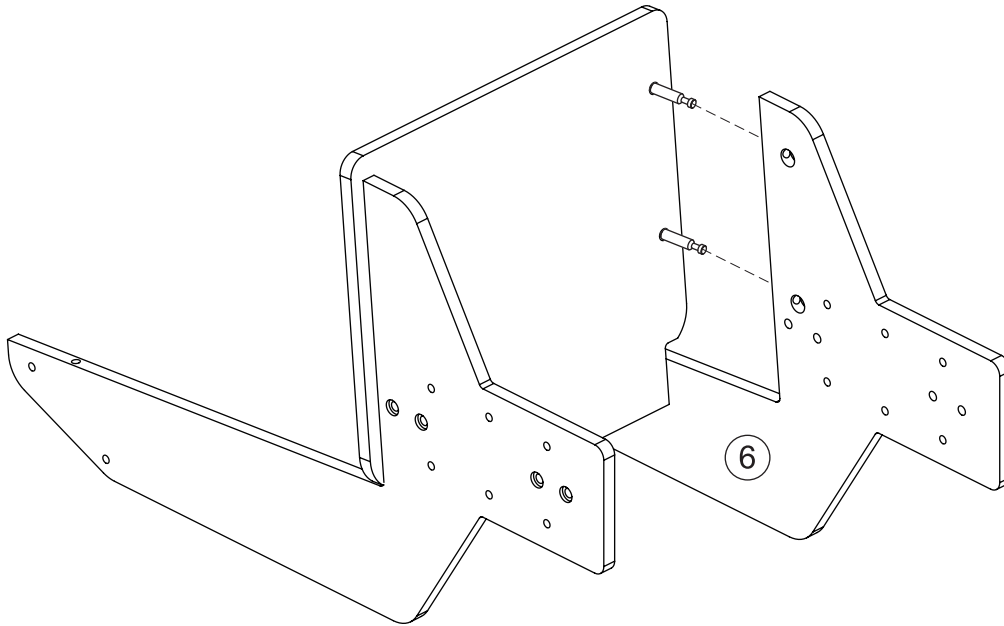

8

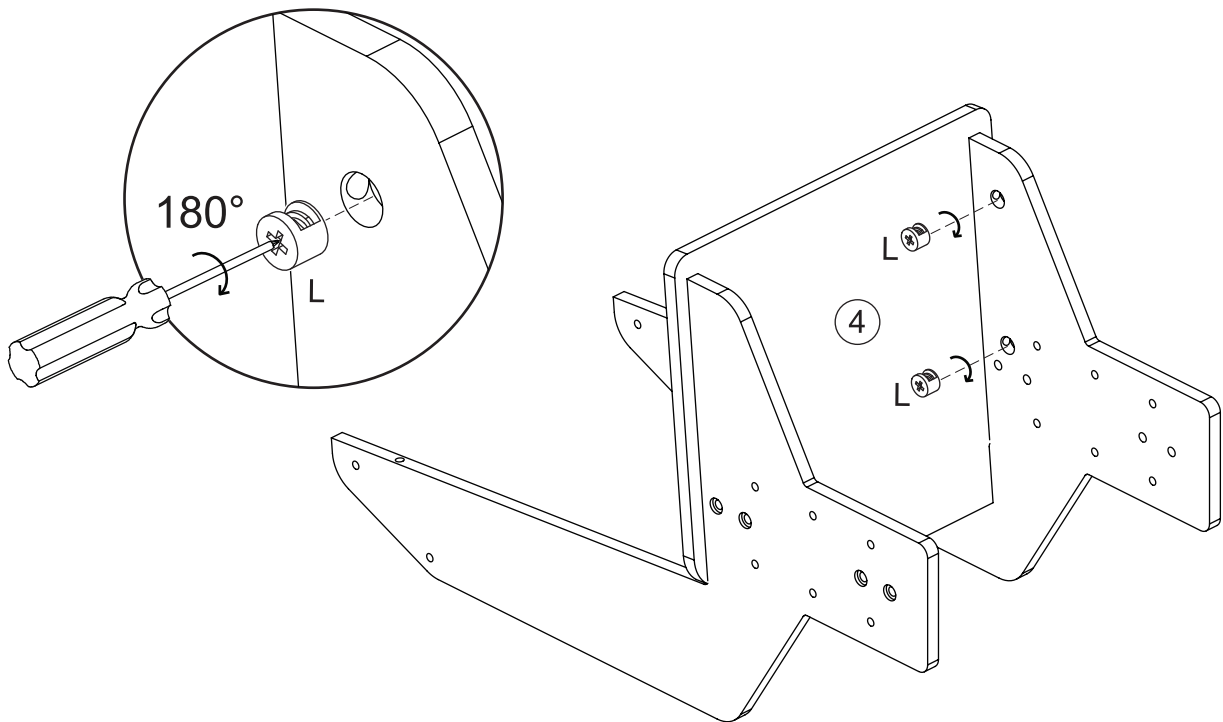

9

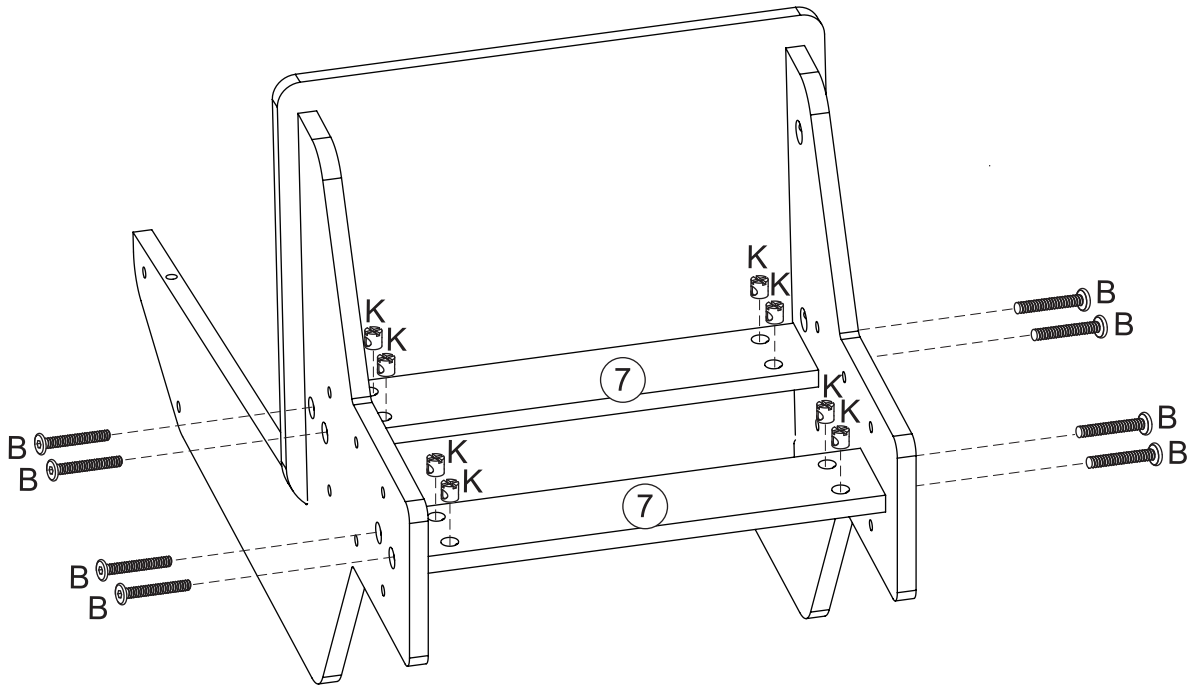

10

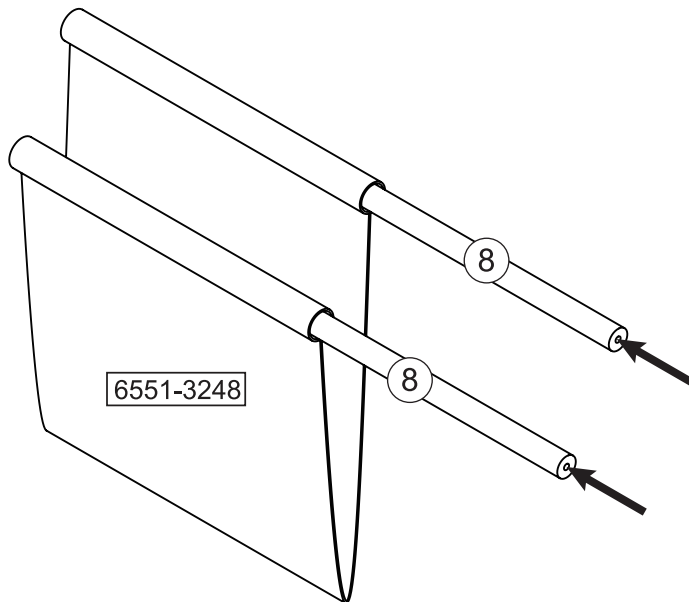

11

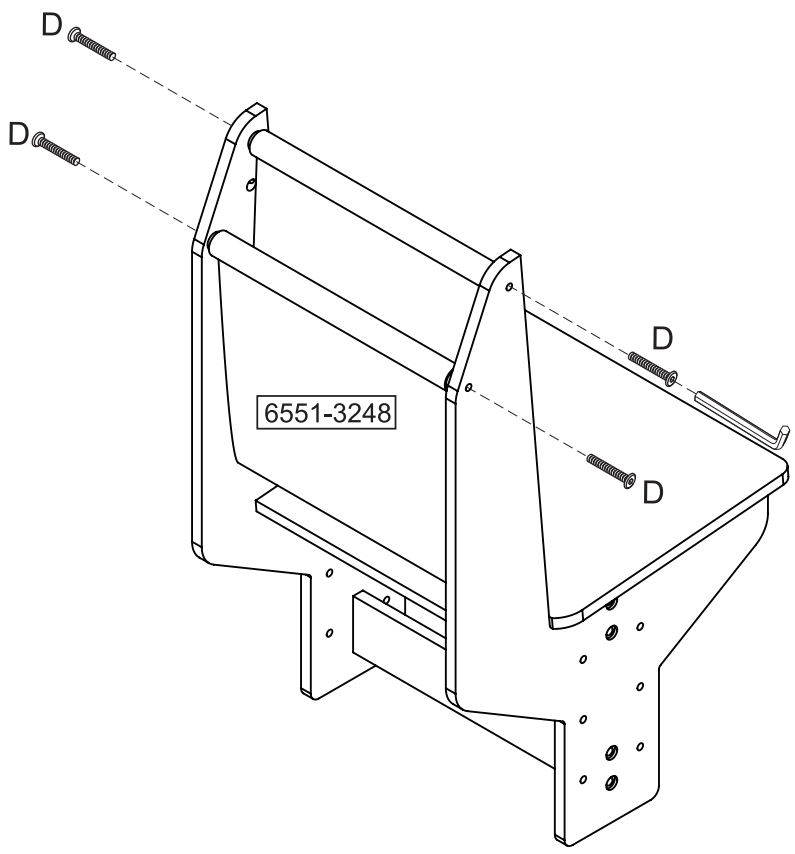

12

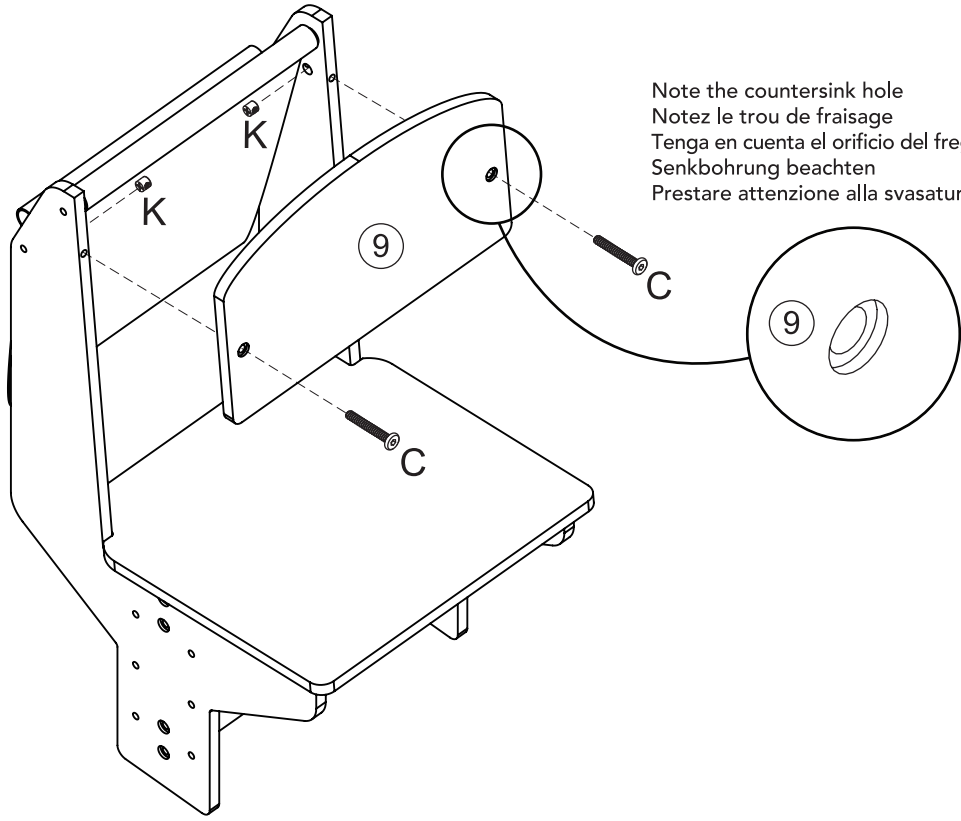

Note the countersink hole
Notez le trou de fraisage
Tenga en cuenta el orificio del fregadero de la encimera
Senkbohrung beachten
Prestare attenzione alla svasatura del foro



13

These holes provided for seat height adjustability. Select your desired height and tightly thread the bolt thru the hole into the nut.

Ces trous sont prévus pour le réglage de la hauteur du siège. Choisissez la hauteur voulue et vissez fermement le boulon dans le trou à l'écrou.

Estos orificios sirven para ajustar la altura del asiento. Selecciona la altura que quieras y enrosca firmemente el perno a través del orificio en la tuerca.

Diese Löcher dienen zur Einstellung der Tischhöhe. Wählen Sie Ihre gewünschte Höhe und schrauben Sie den Befestigungsbolzen fest durch das Loch in die Mutter.

Questi fori sono forniti per la regolazione dell'altezza della seduta. Scegliere l'angolo desiderato ed avvitare saldamente il bullone attraverso il foro nel dado.

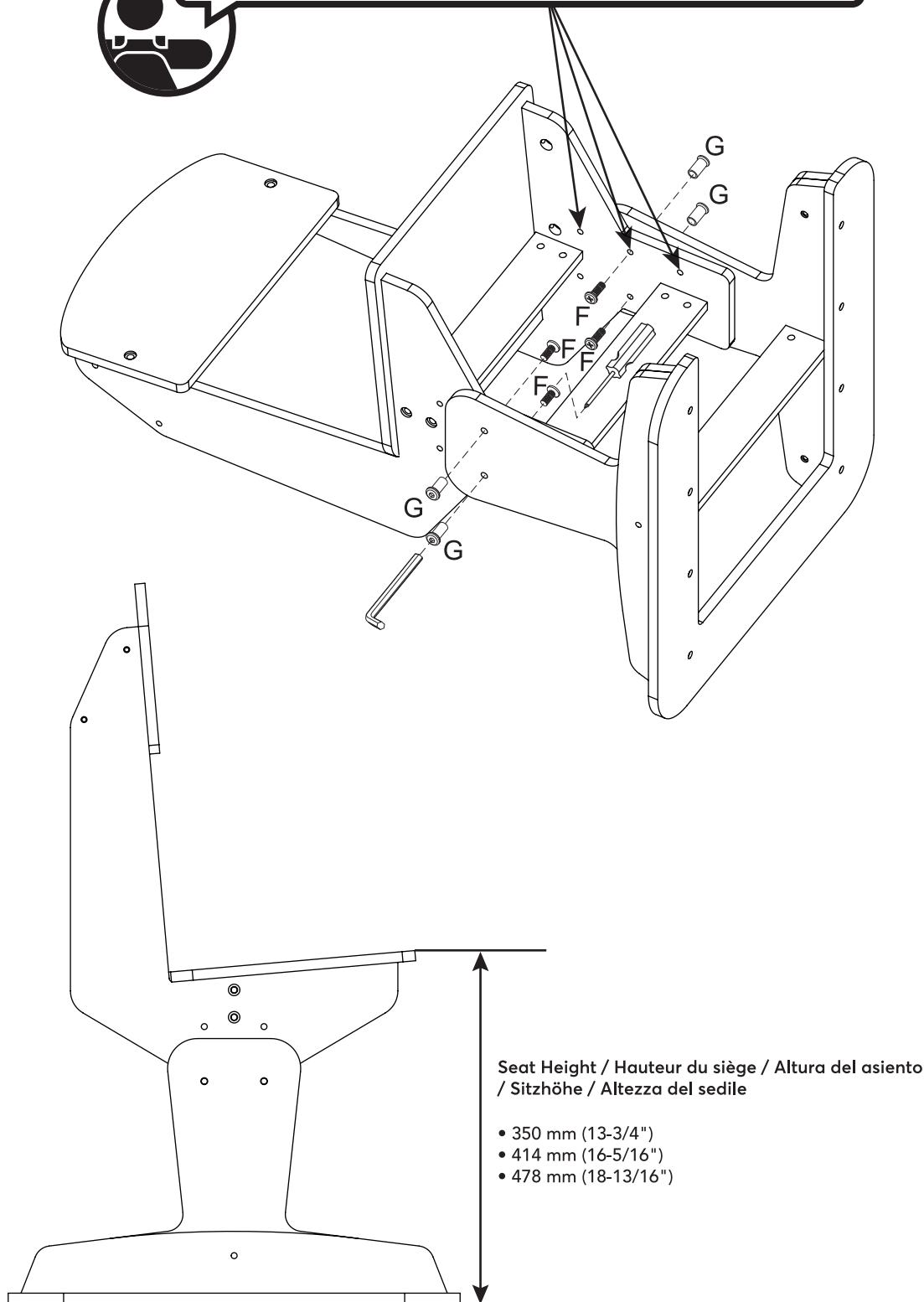

14 x 2

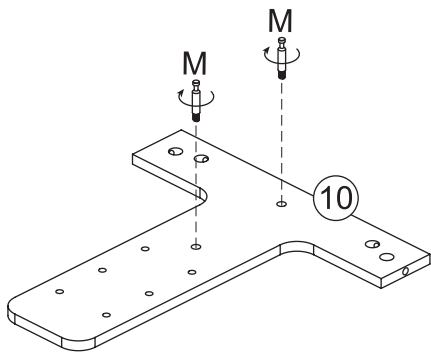

15

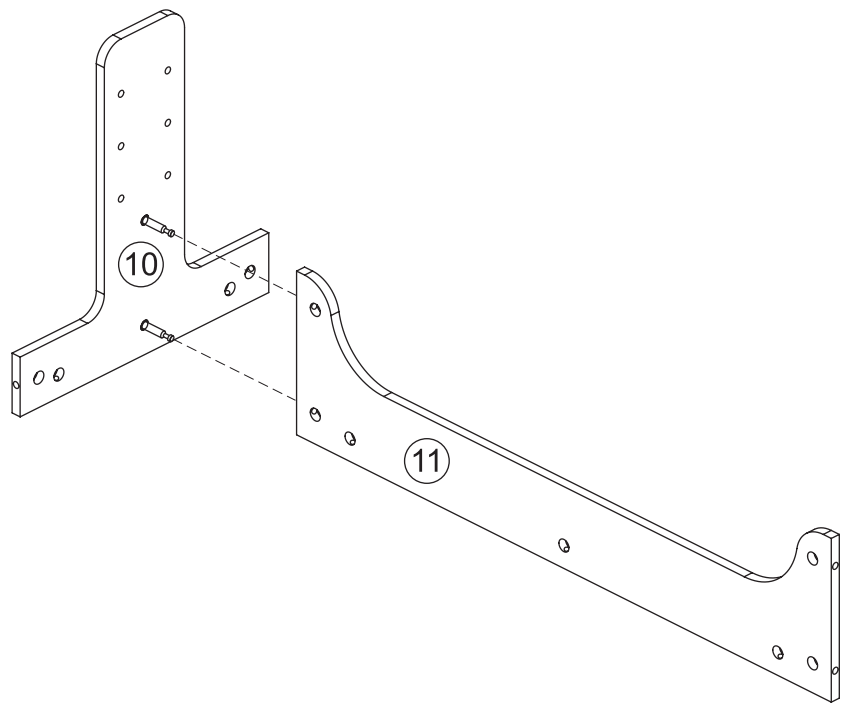

16

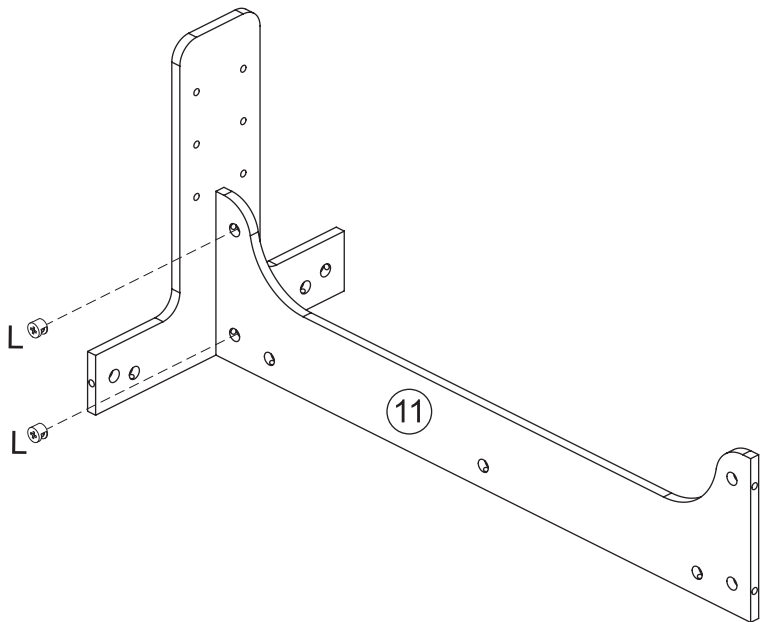
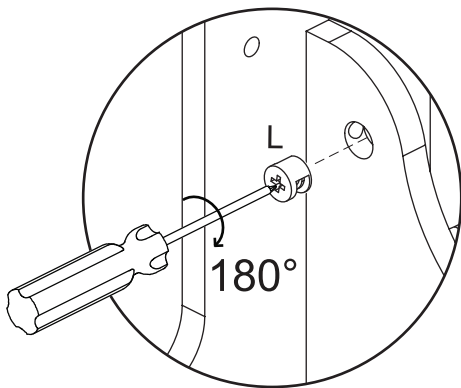

17

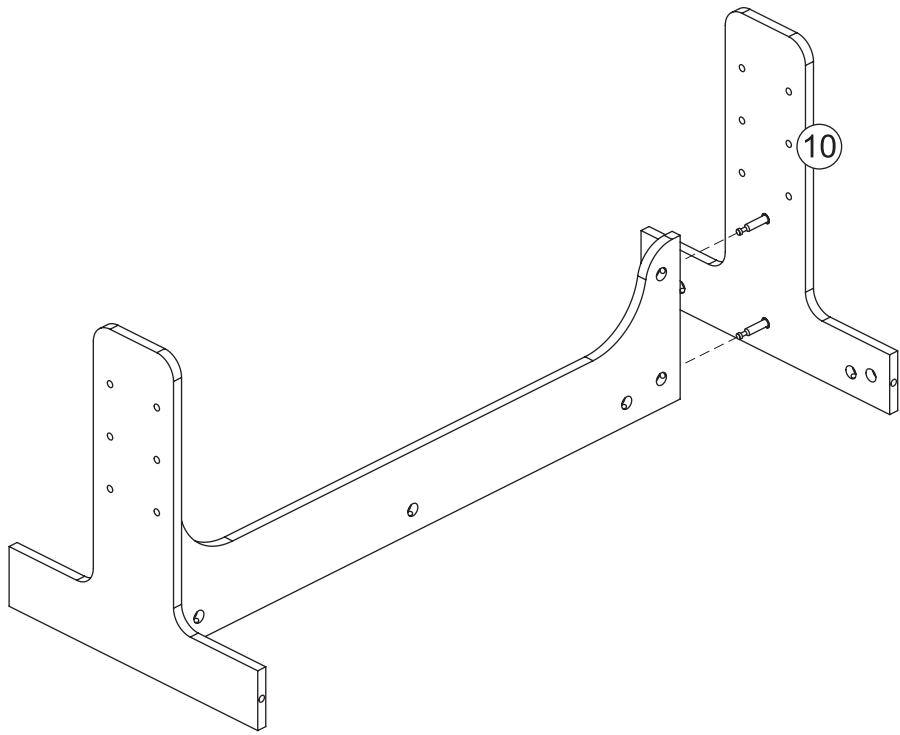

18

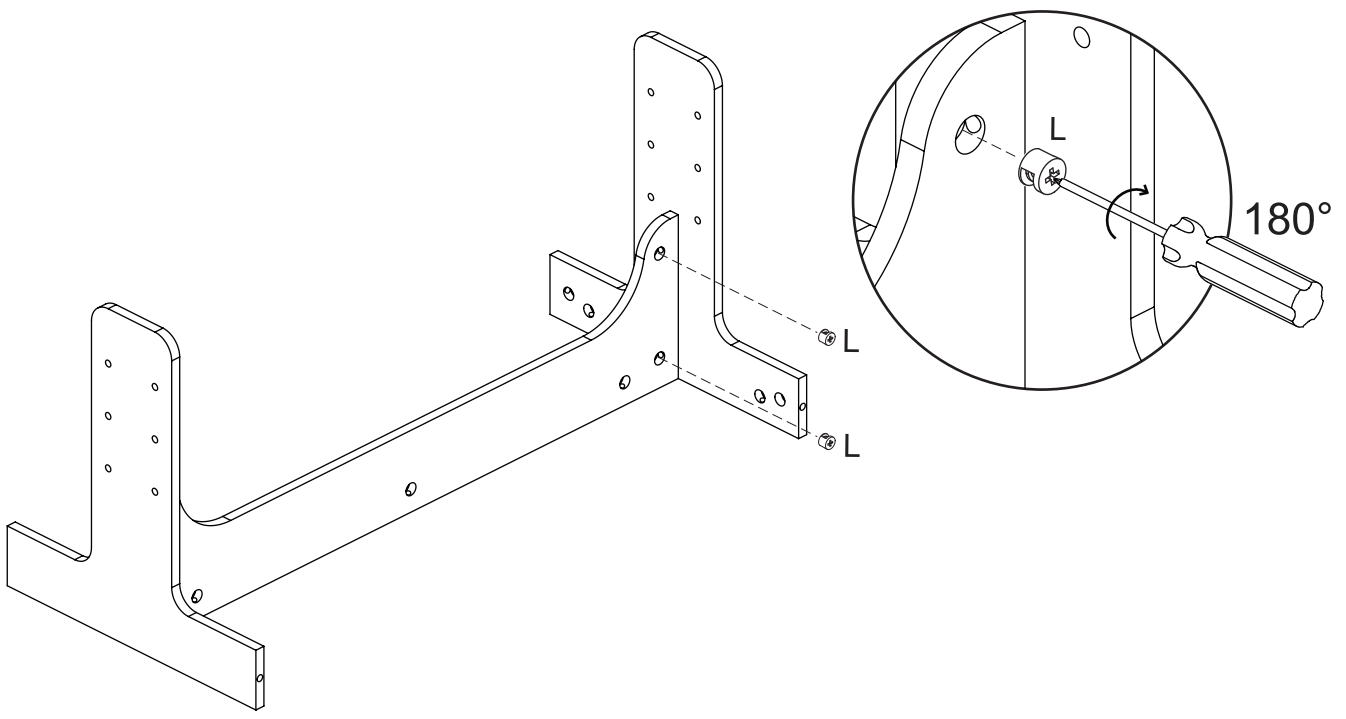

19

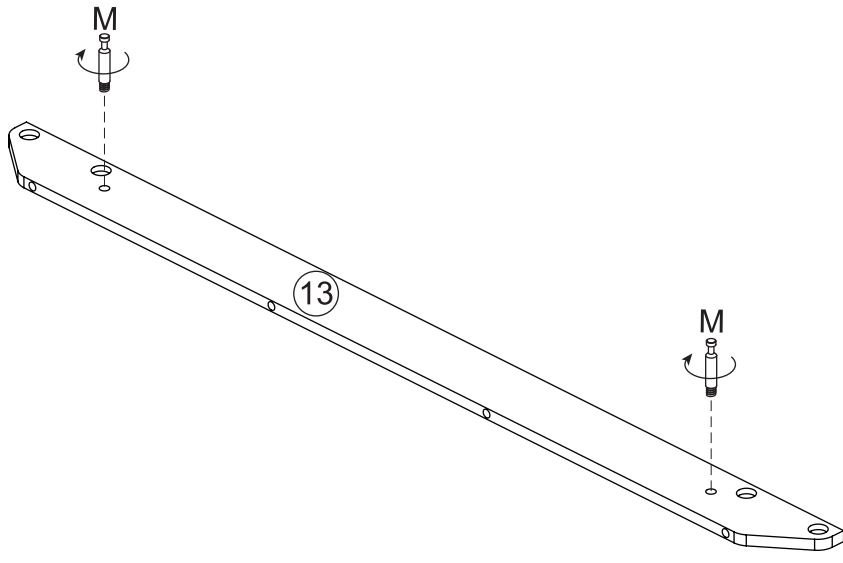

20

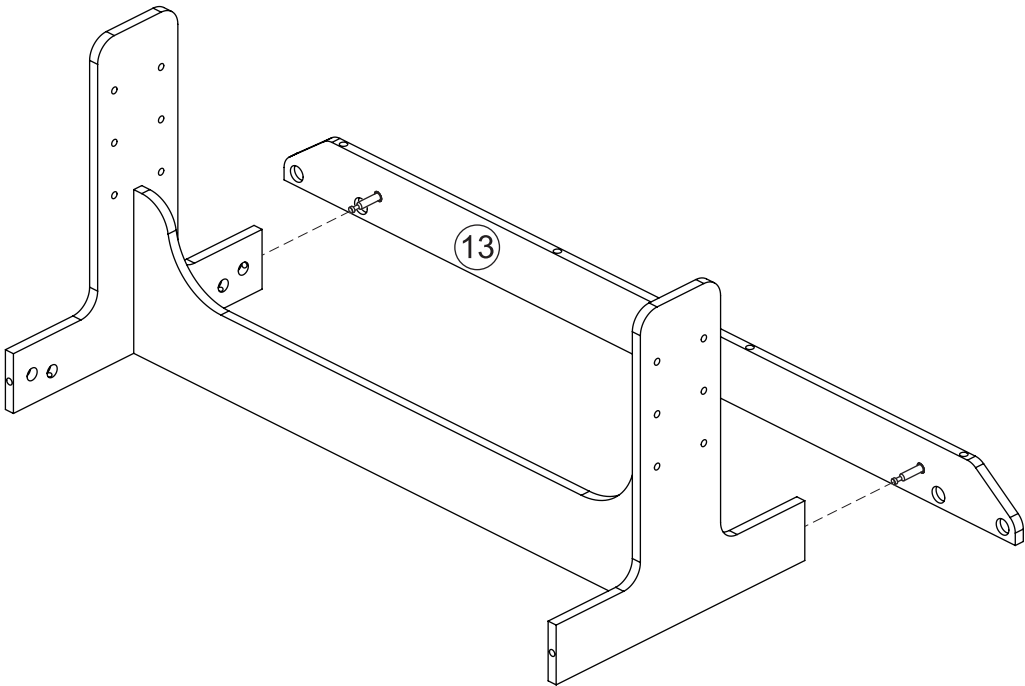

21

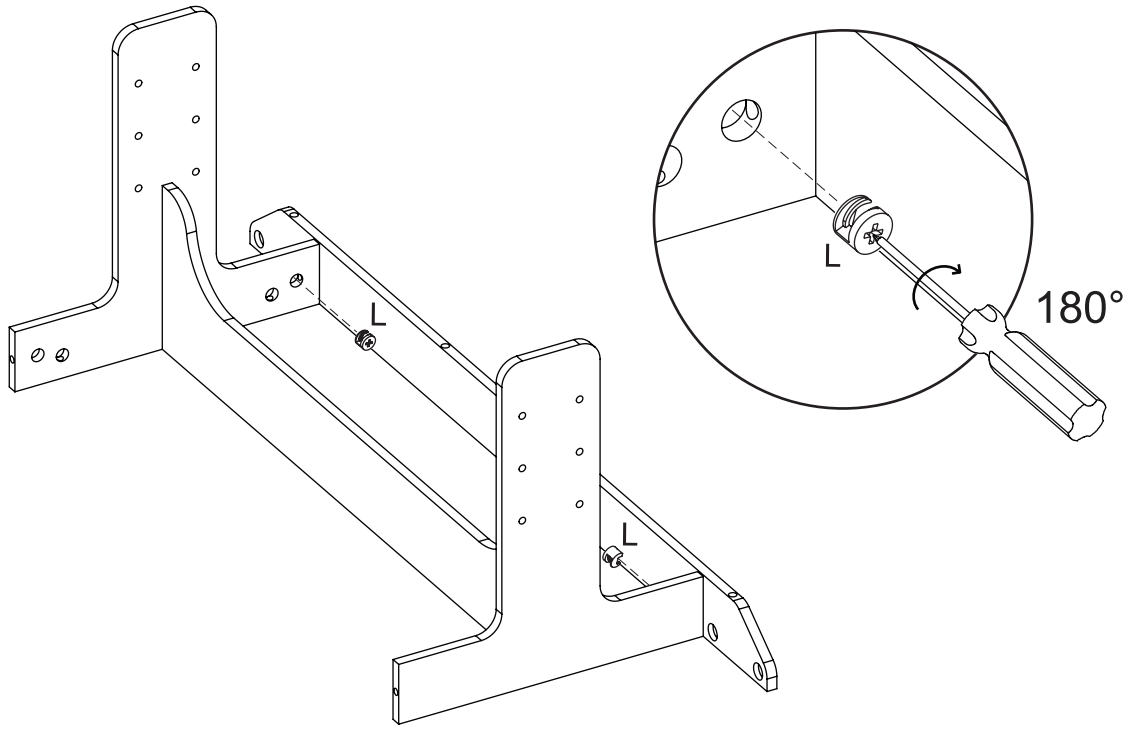

22 x 2

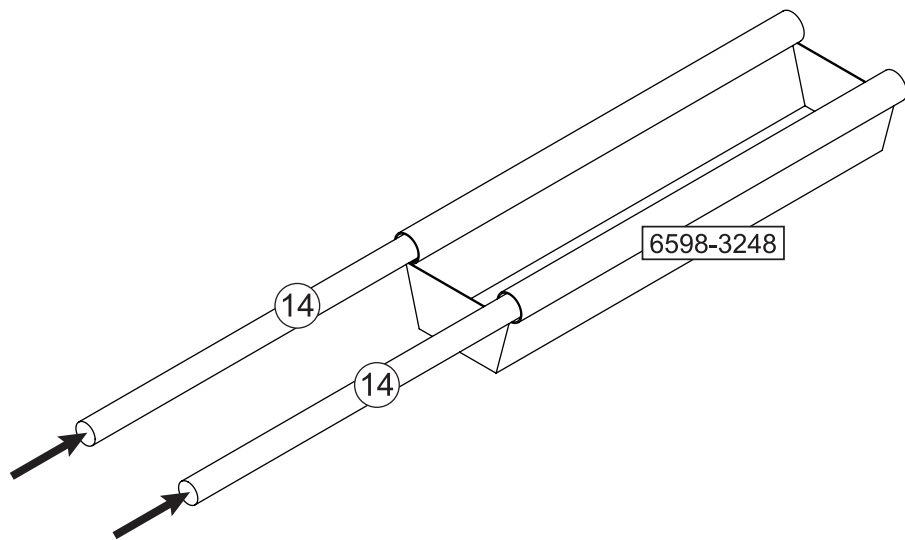

23

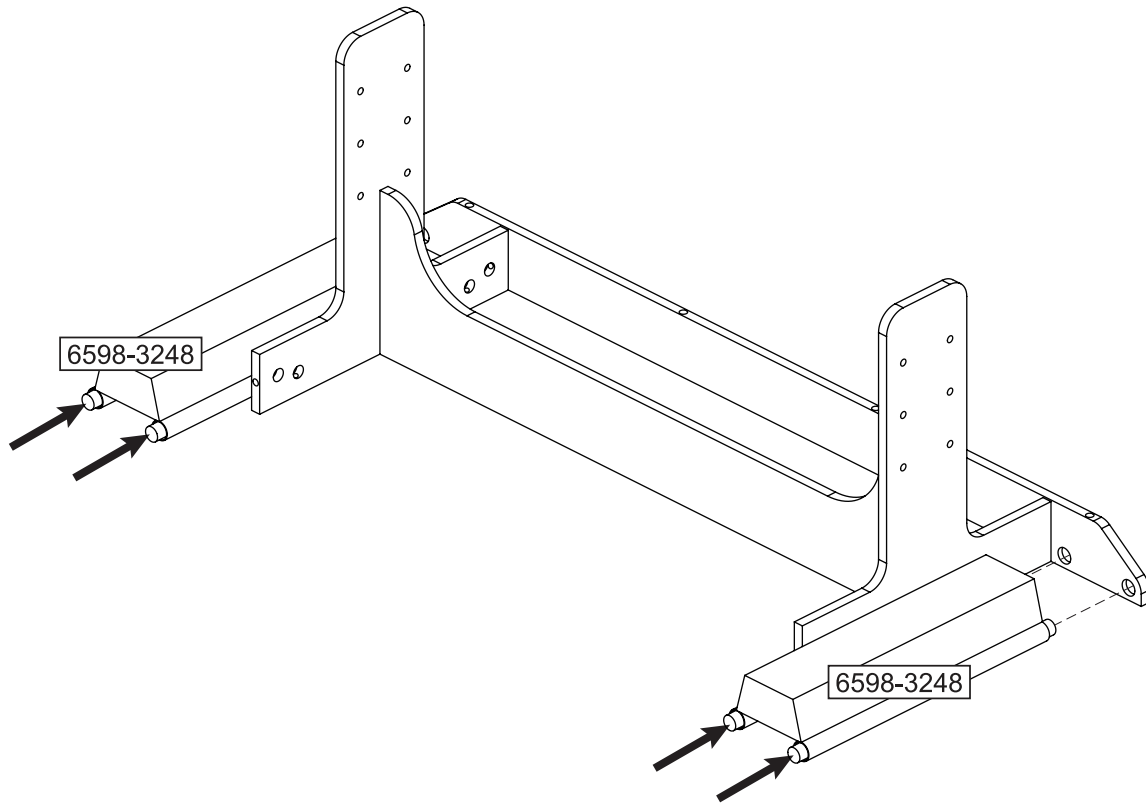

24

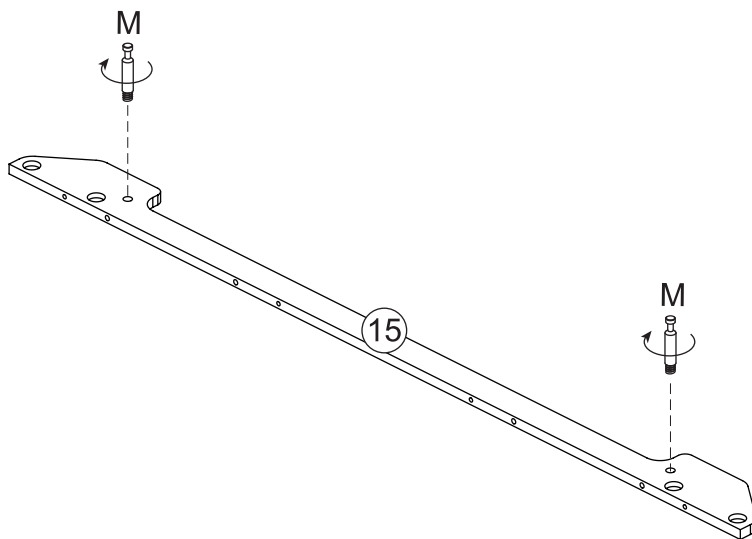

25

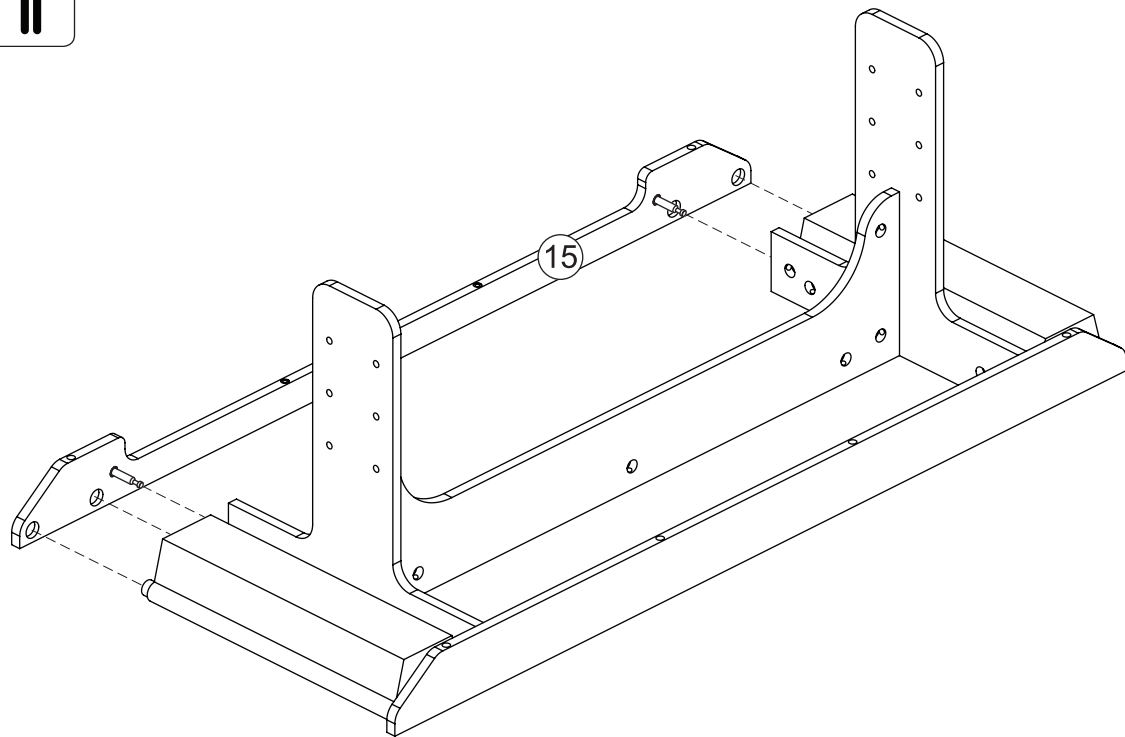

26

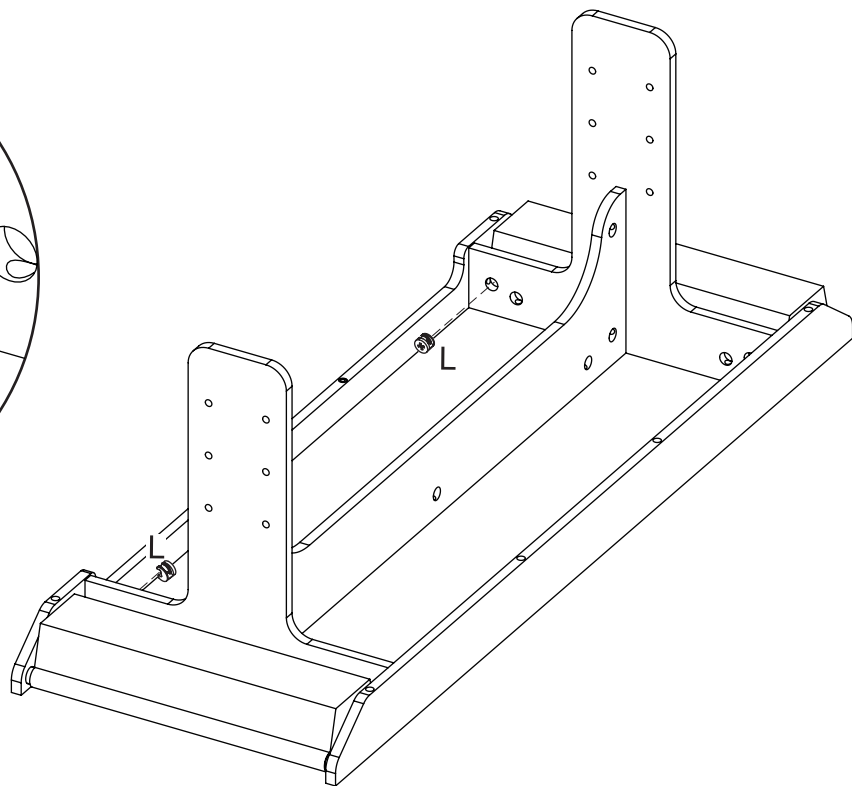
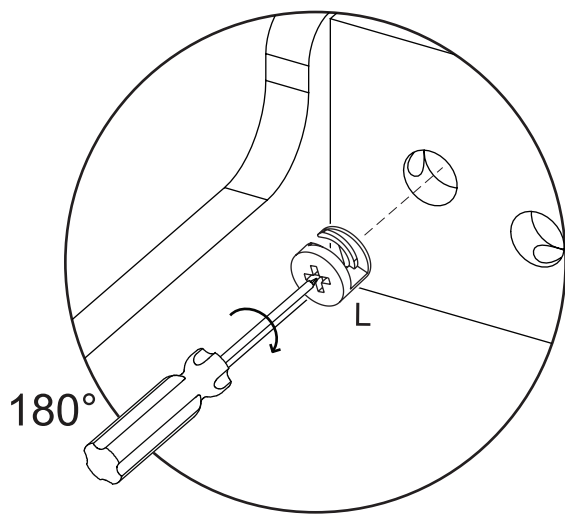

27

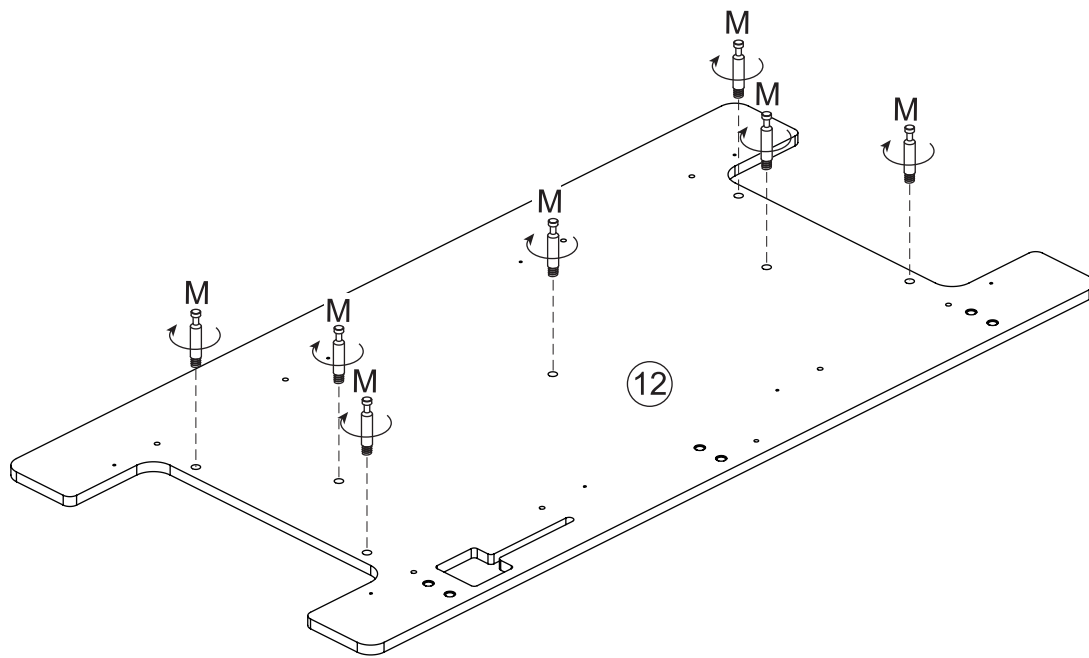

28

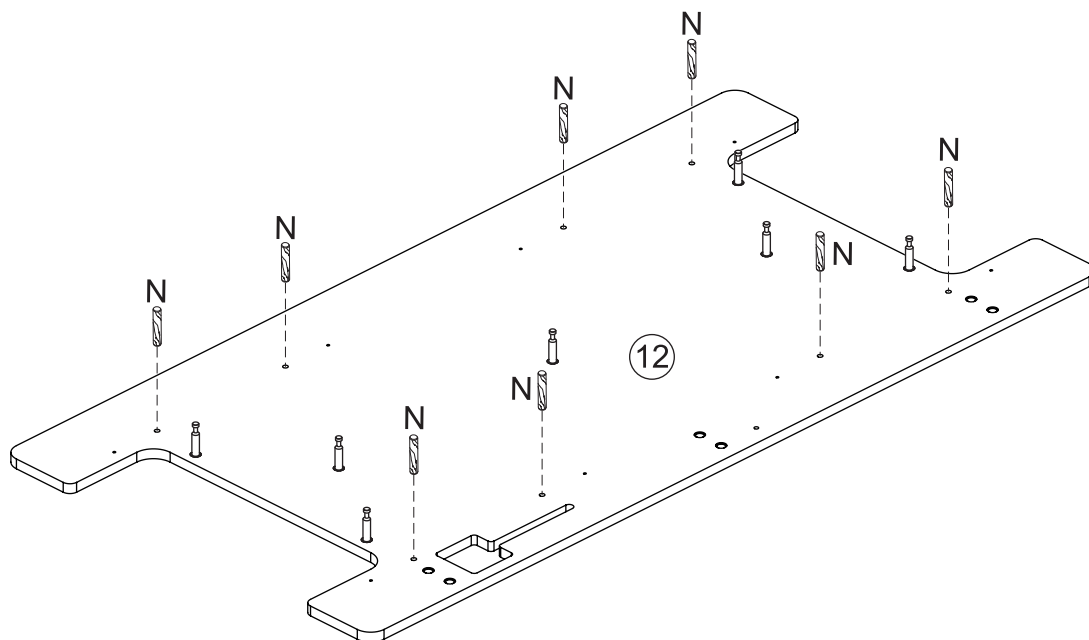

29

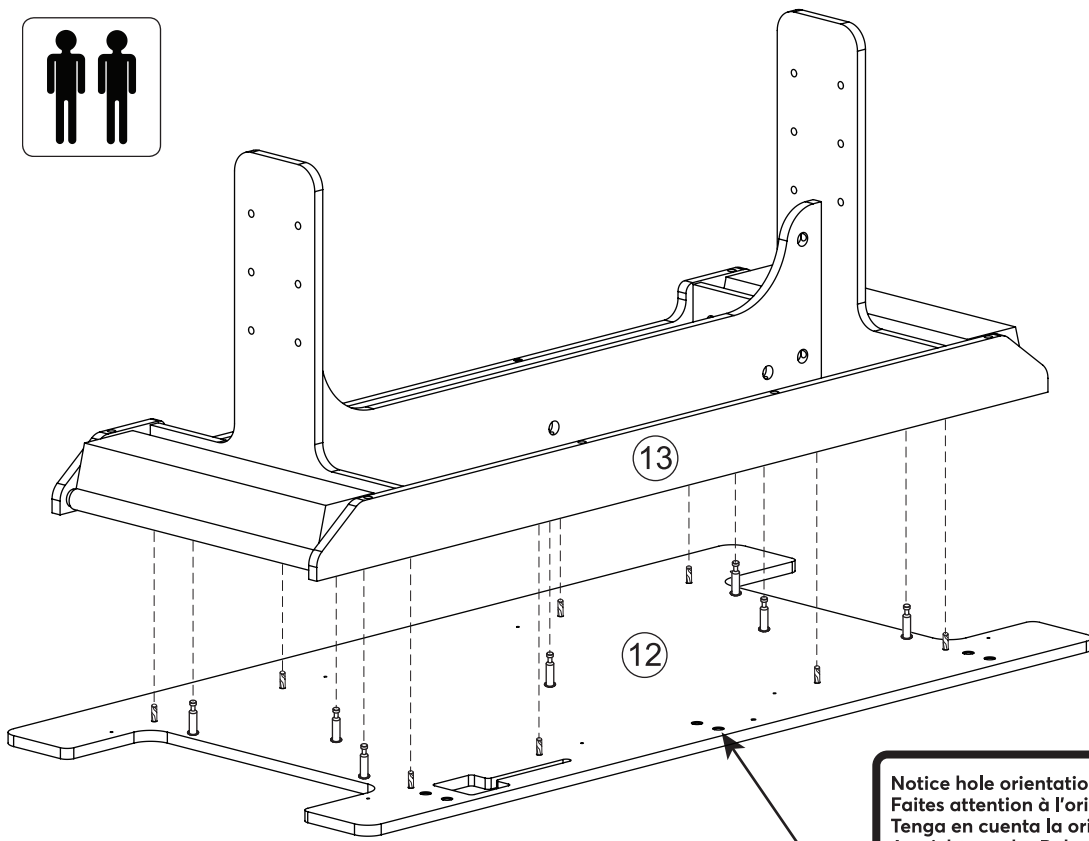

Notice hole orientation
Faites attention à l'orientation des trous
Tenga en cuenta la orientación de los orificios
Ausrichtung der Bohrungen beachten
Prestare attenzione all'orientamento dei fori

30

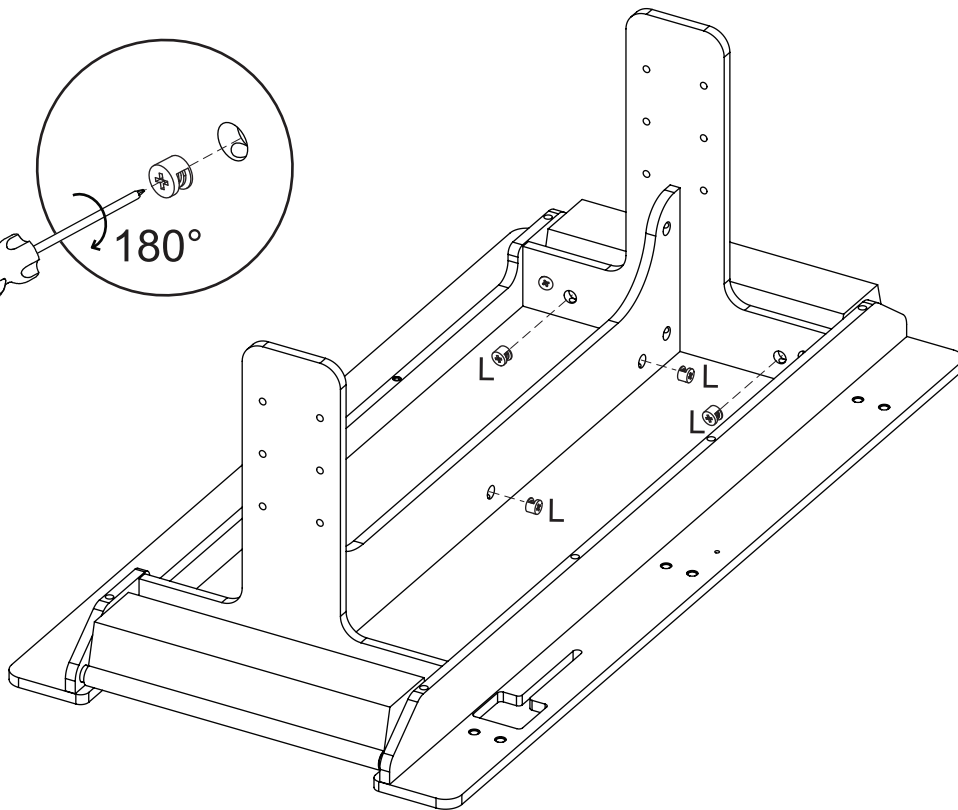
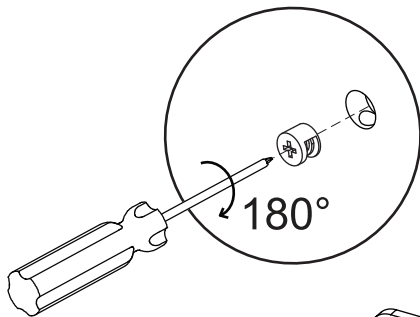

31

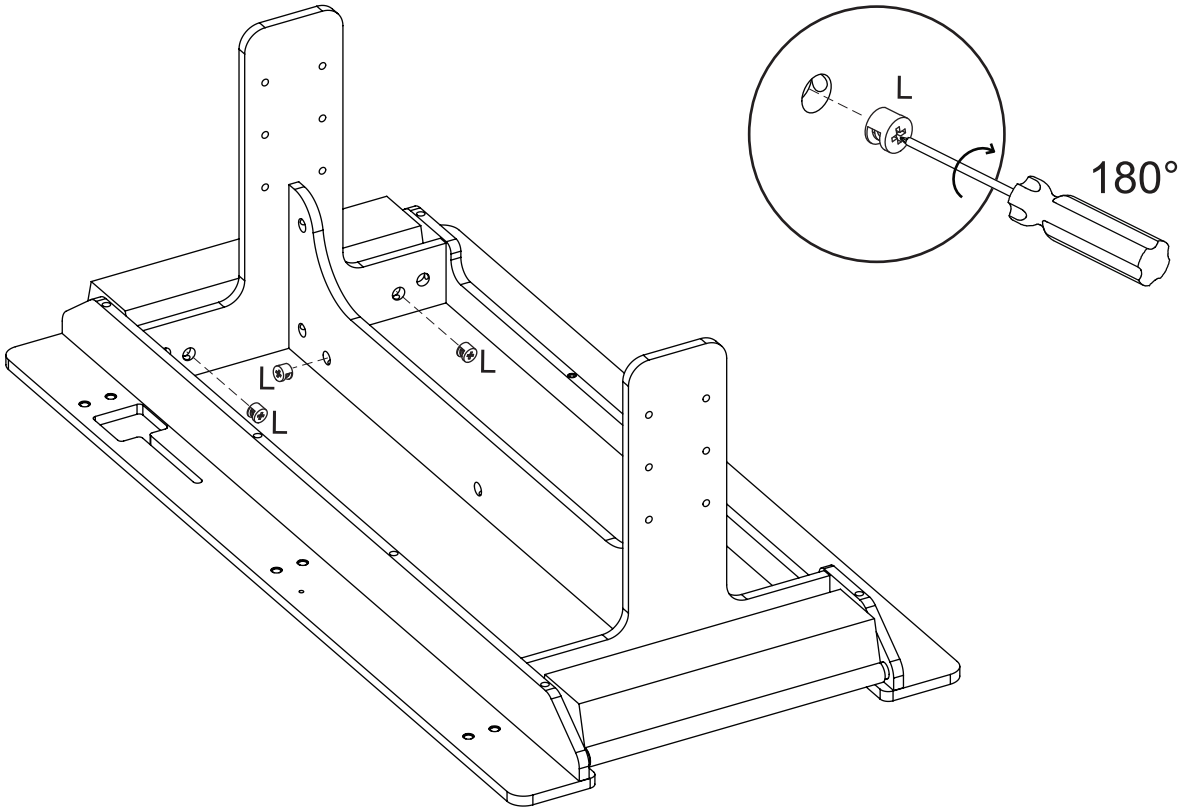

32

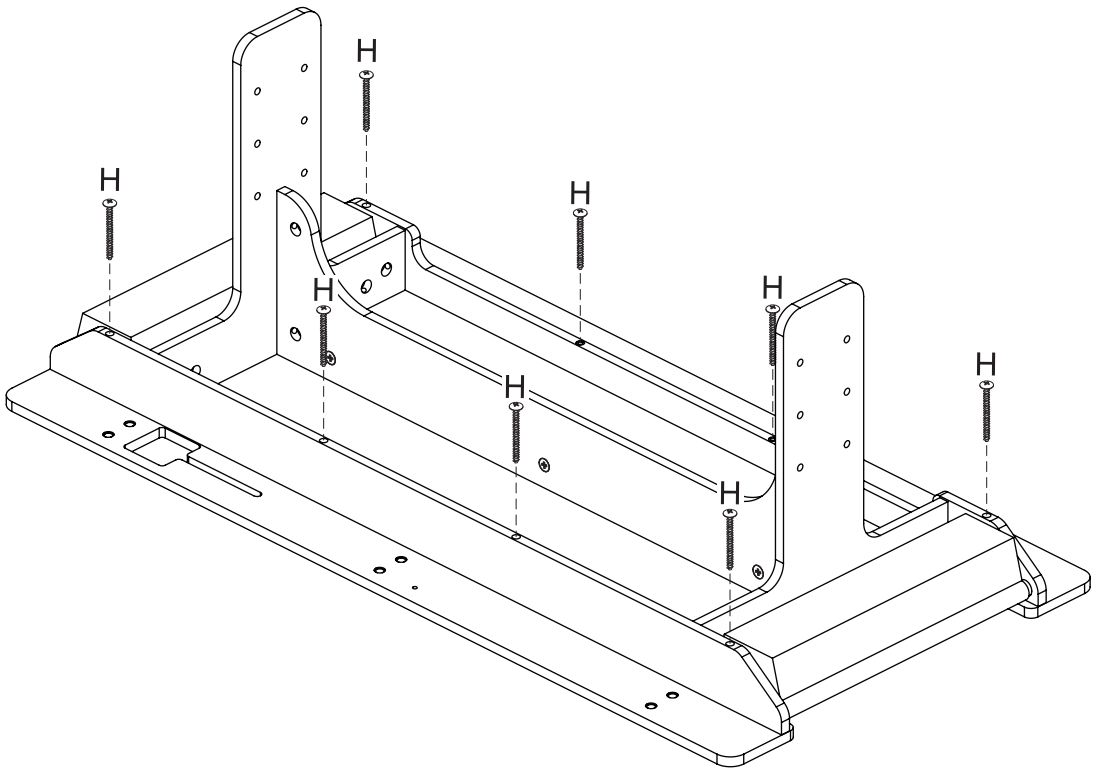

europcustomerservice@kidkraft.com
+31 20 305 8620
M-F from 09:00 to 17:30 (GMT+1)

parts.kidkraft.eu



33

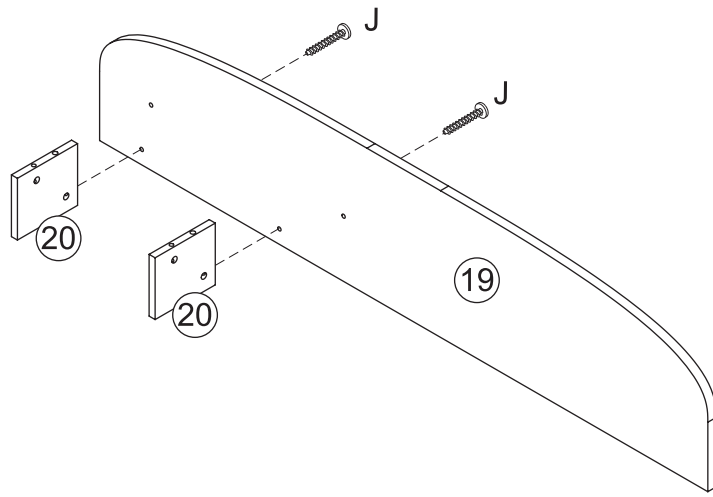

34

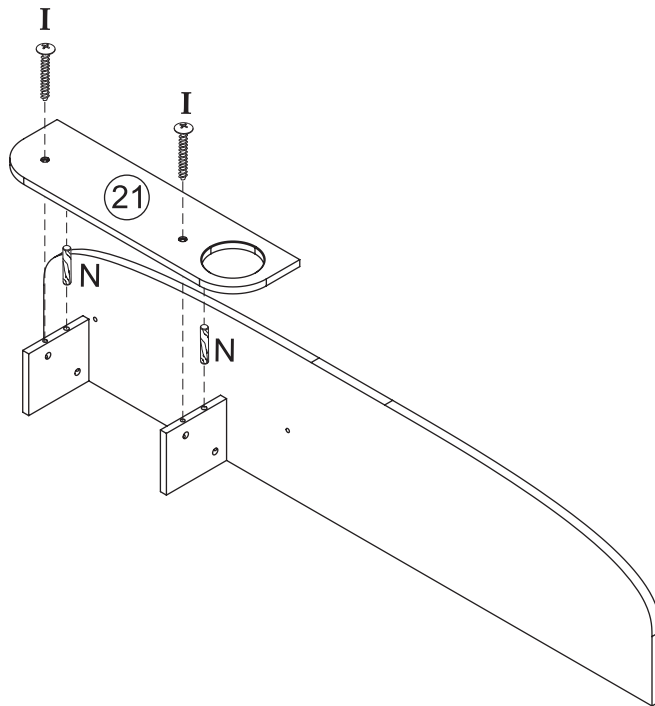

35

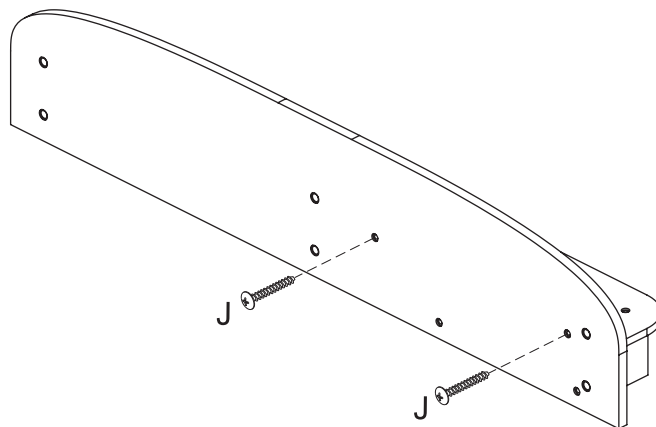

36

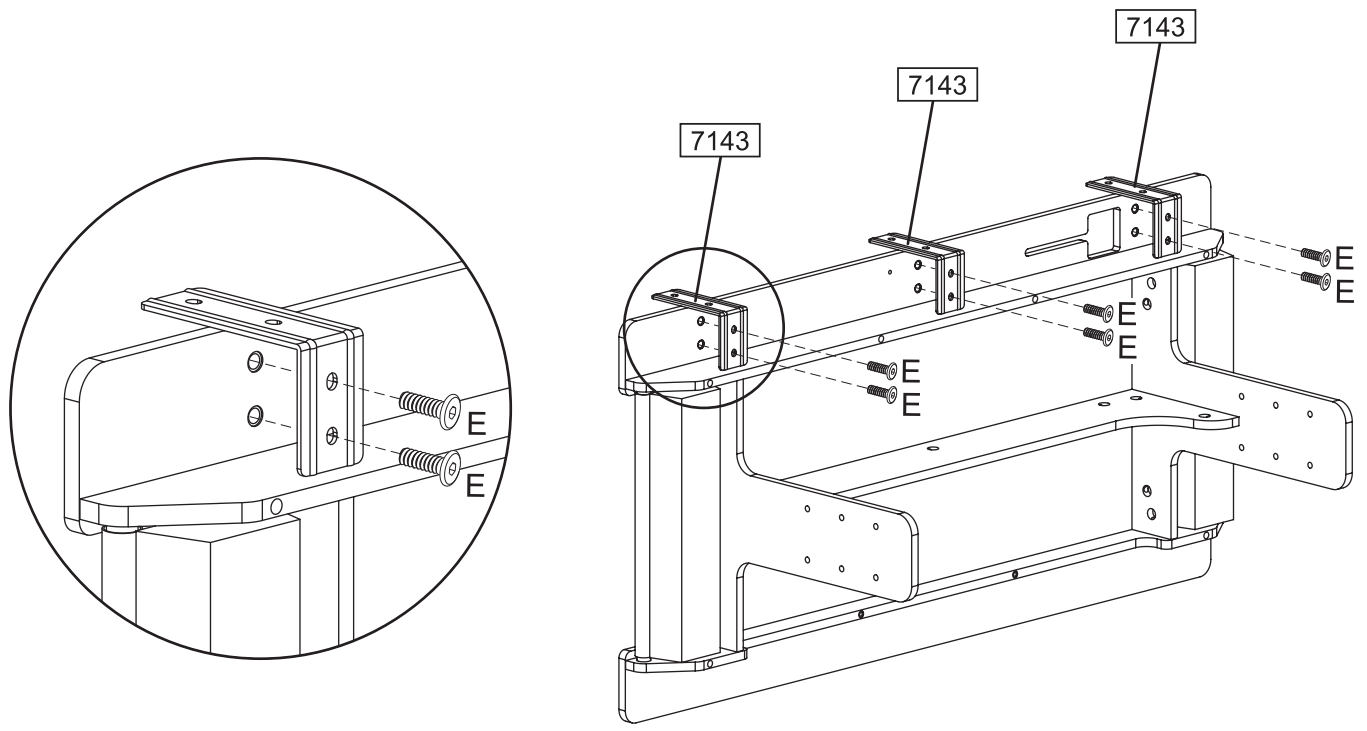

37

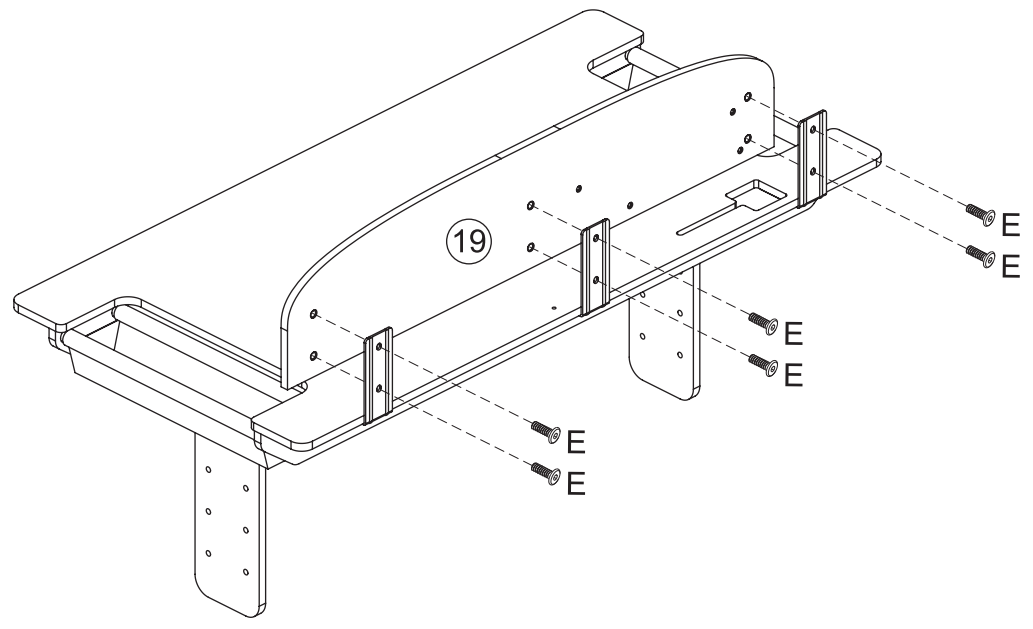

europcustomerservice@kidkraft.com
+31 20 305 8620
M-F from 09:00 to 17:30 (GMT+1)

parts.kidkraft.eu



38

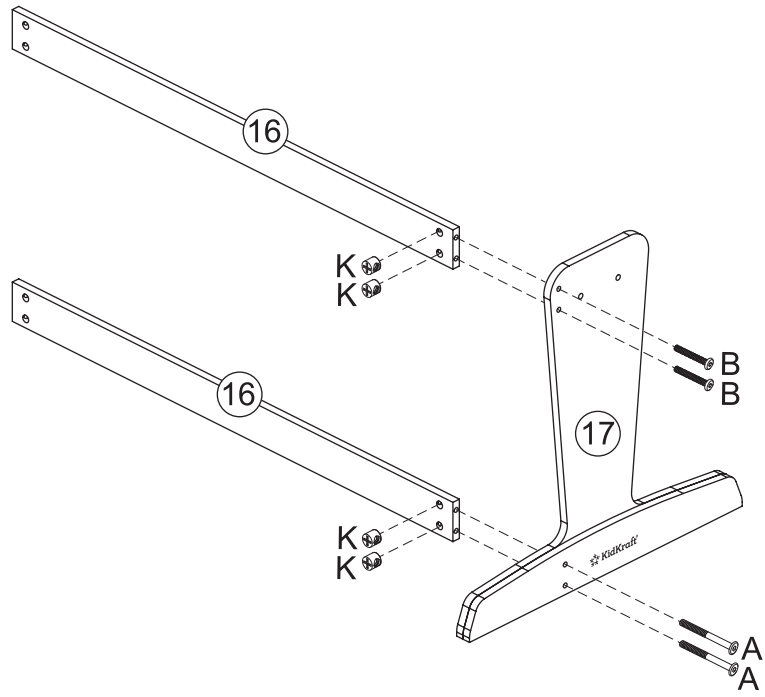

39

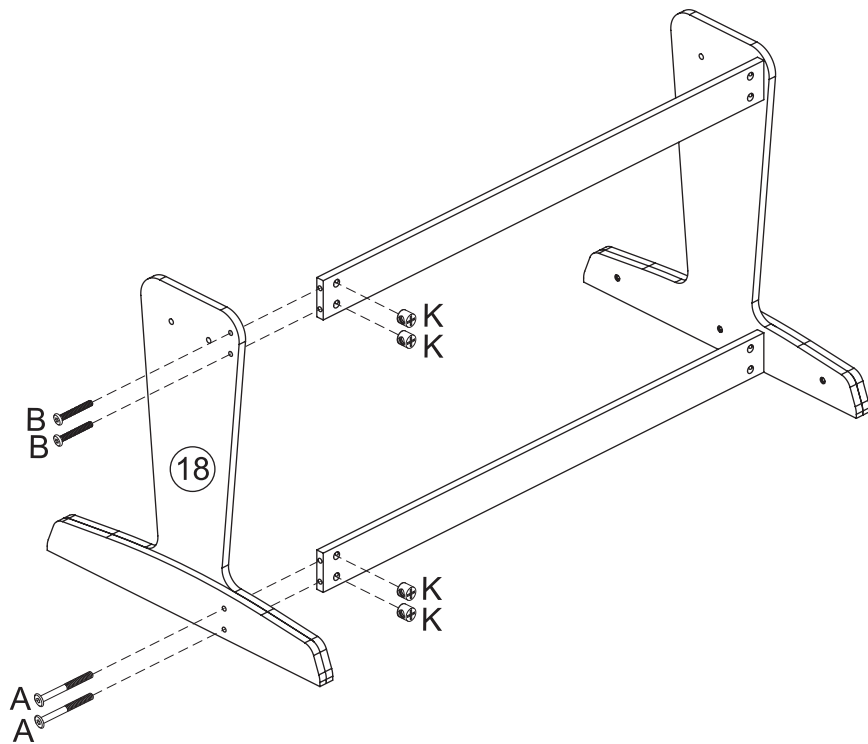

40

These holes provided for table height adjustability. Select your desired height and tightly thread the bolt thru the hole into the nut.

Ces trous sont prévus pour le réglage de la hauteur de la table. Choisissez la hauteur voulue et vissez fermement le boulon dans le trou à l'écrou.

Estos orificios sirven para ajustar la altura de la mesa. Selecciona la altura que quieras y enrosca firmemente el perno a través del orificio en la tuerca.

Diese Löcher dienen zur Einstellung der Tischhöhe. Wählen Sie Ihre gewünschte Höhe und schrauben Sie den Befestigungsbolzen fest durch das Loch in die Mutter.

Questi fori sono forniti per la regolazione dell'altezza del tavolo. Scegliere l'angolo desiderato ed avvitare saldamente il bullone attraverso il foro nel dado.

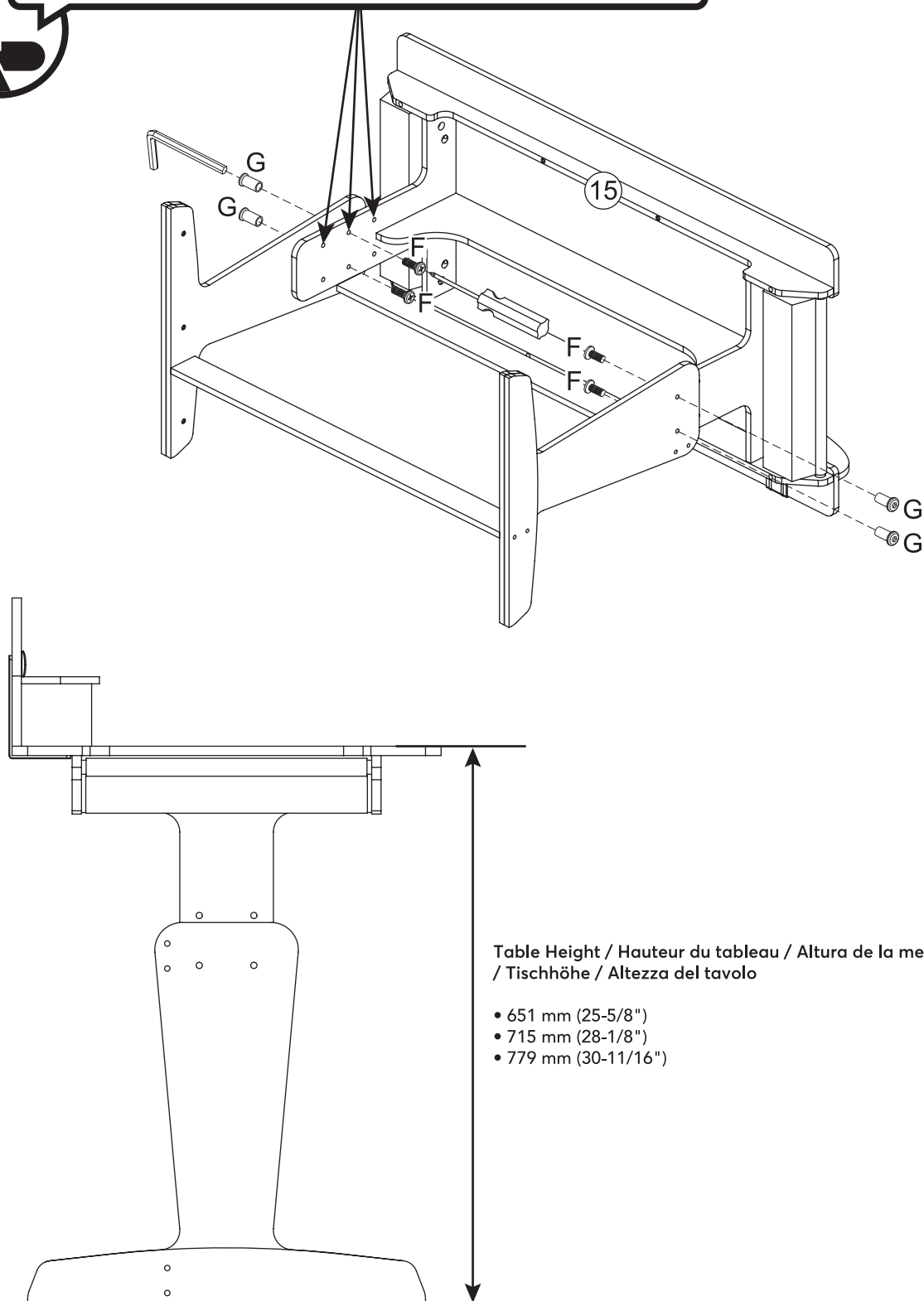

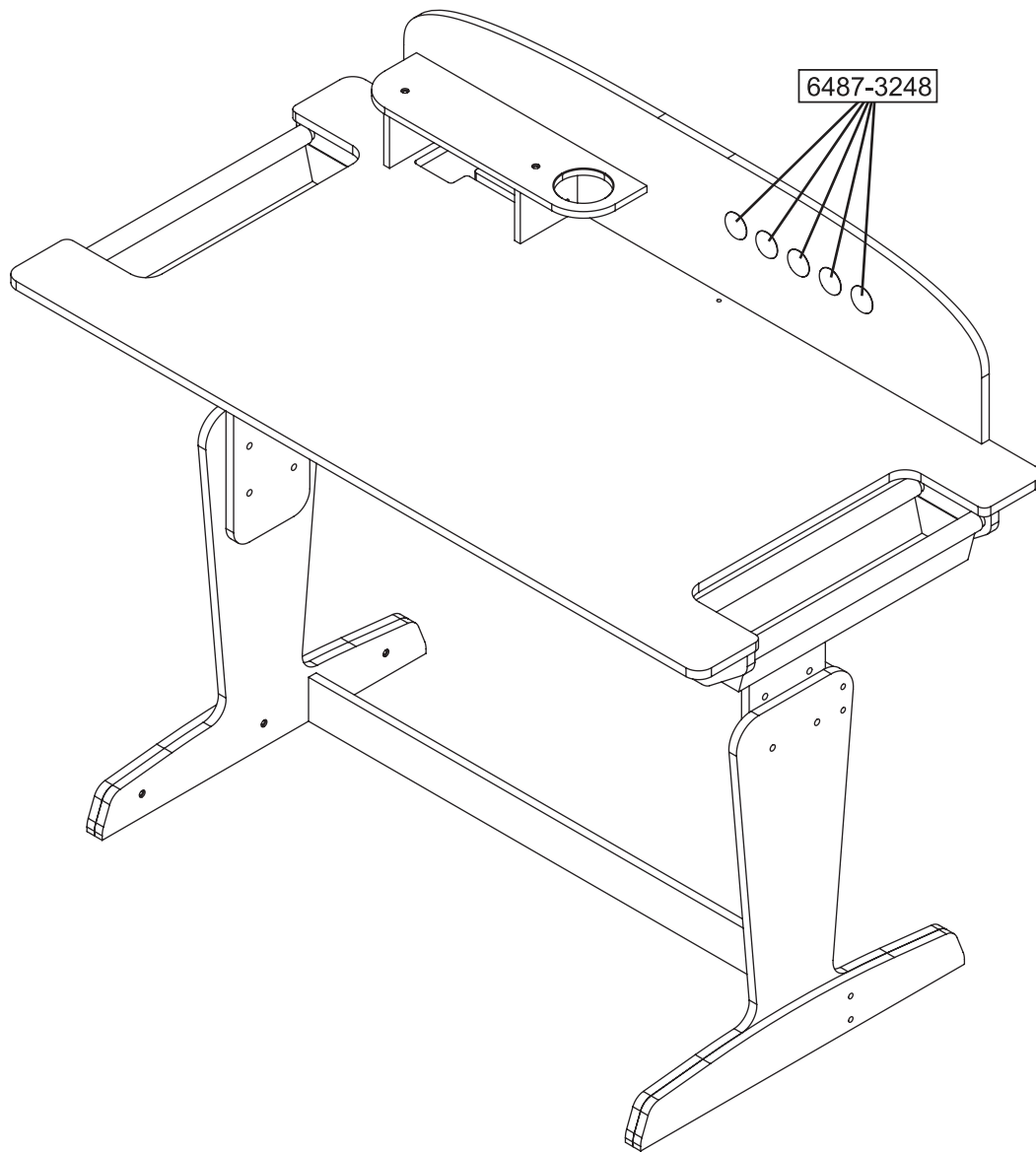

Wall Anchor
 Dispositif d'ancrage au mur
 Anclaje de Pared
 Wandanker
 Fissaggio a parete

42

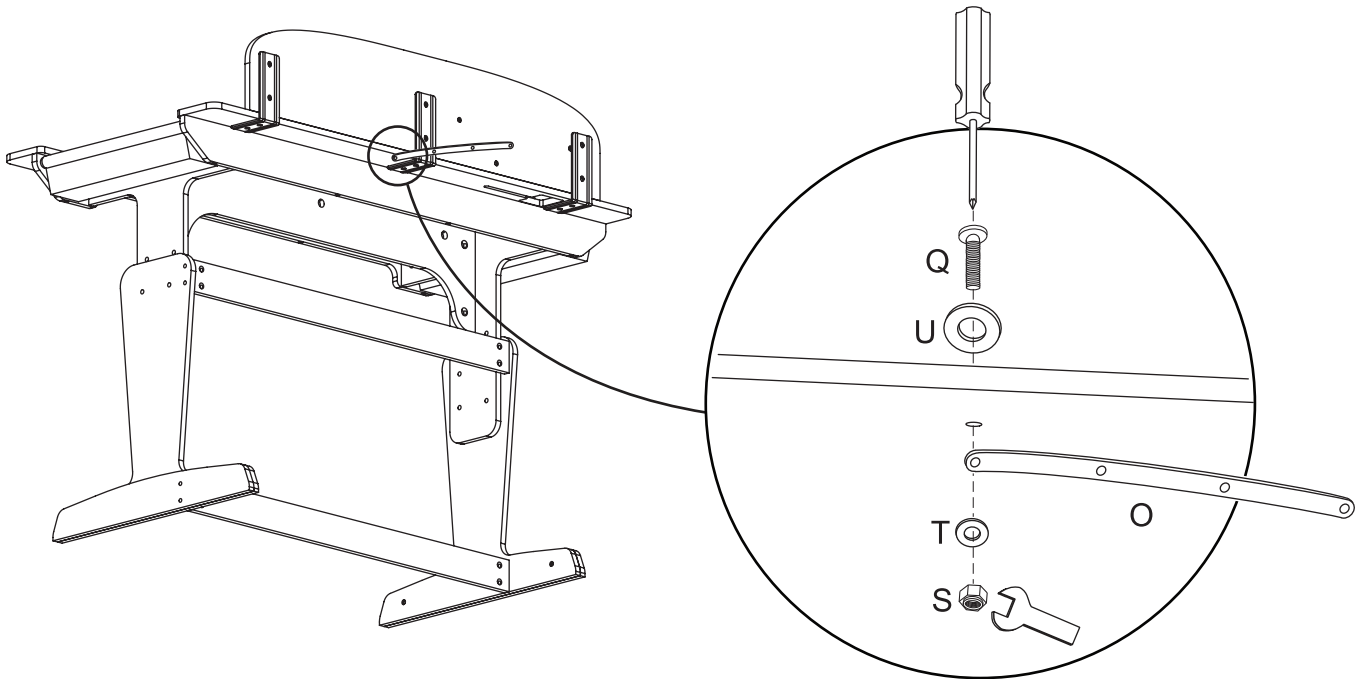

43

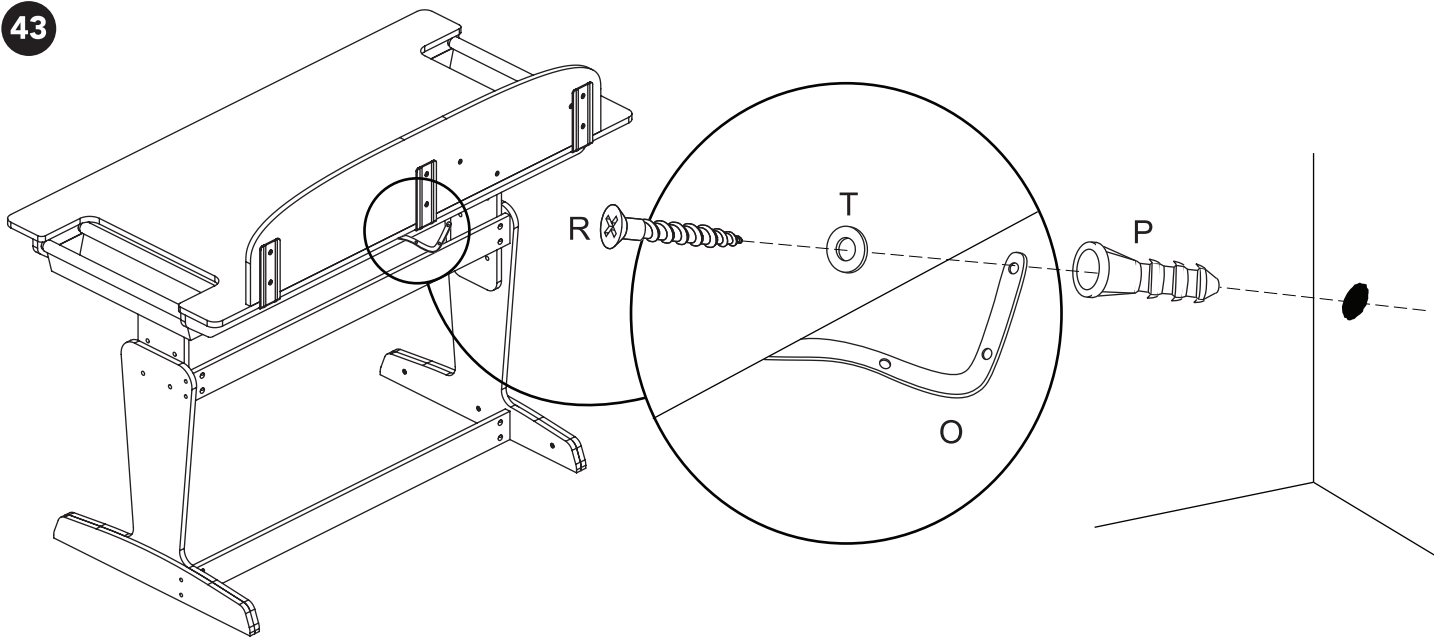

⚠ WARNING:
 Do not install on a wall where items can fall off and injure a child.

⚠ AVERTISSEMENT:
 Ne pas installer sur un mur duquel d'autres objets risquent de tomber et blesser un enfant. A monter par un adulte.

⚠ ADVERTENCIA:
 No instale en una pared donde otros artículos se puedan caer y lastimar a un niño.

⚠ VORSICHT:
 Bitte nicht an einer Wand anbringen, wo Dinge herunterfallen und Kinder verletzen könnten.

⚠ AVVERTENZA:
 Non installare su un muro da cui gli articoli possono cadere e ferire il bambino.