



INSTALLATION
OPERATION
MAINTENANCE
MANUAL

FOR

MODEL RP 4500 SARG

MODEL RP 4500 SAR

RACK 'N PINION™
STRONG ARM
ROLL MASTER WITH GANTRY

ATTENTION DISTRIBUTOR: DO NOT DISCARD.
PLEASE GIVE THIS MANUAL TO THE CUSTOMER
WHEN THE UNIT IS DELIVERED.

RP4500SARG SYSTEM INSTALLATION

This Rack 'N Pinion™ tarping system has been the system of choice in the roll-off industry for over a decade. Our patented hydraulic arms and gear assembly combined with our "Strong Arm" technology and Everlast Tarp Roller produce the only fully hydraulic system known for reliability and low maintenance. The reinforced "C" Channel provides better leverage, greater control and longer life.

Applications: Cable hoist roll-off trailers

Container style/size: Up to 24 foot containers

Standard tarp: Heavy duty mesh

MAINTENANCE TIPS

1. Check all fittings and connections weekly. Correct as necessary.
2. Grease Arm Pivot Pins & Lubricate Gantry Legs weekly.
3. Apply a dry film lubricant to Telescopic Extensions weekly.
4. Spray lube the Rack & Pinion Gears weekly.
5. The Relief Valves (2) may have to be re-adjusted periodically.
6. Replace/Repair any broken/worn parts immediately.

TIPS FOR THE OPERATOR

1. Do not overhang the Roller/Stabilizer Bar past the end of the container. The Stabilizer Bar is designed to rest on the top rear of the container ONLY.
2. Overshooting the container and retracting the Arms causes the arms to be unsupported, which will lead to damage to the arms and pivot mechanism!
3. Operate Engine at low RPM's only.
- 4. WARNING:** DO NOT operate under or near overhead wires.
5. Keep clear of moving parts.
6. Make sure that no one is on or around the container when the unit is in operation.
7. If Arms stop while in motion, they have likely come into contact with an obstruction (this indicates that the relief valve is operating properly). Return the arms to their original position, clear the obstruction and re-activate the unit.

INDEX

RPSARG Schematic	2	Installing Tarp / Roller / Arms	14-18
RPSAR Schematic	3	Installing Flow Diverter & Control Valve	19-27
Schematics	4-7	Final Checks & Adjustments	27
Legal Information	8	Operating the Unit	28
Mounting Gantry & Roll Rest Assy.	10-11	Hydraulic Fitting Chart	29
Locating Pivot Point & Installing Mounting Bracket Assemblies	11-14	Warranty Information	33

REVISTONS

REV	DESCRIPTION	DATE	APPROVED
A	INITIAL RELEASE -	04/05/07	P. DOAN
B	REVISED	06/19/07	P. DOAN
C	RACK 'N PINION REDESIGN	05/05/17	RDS

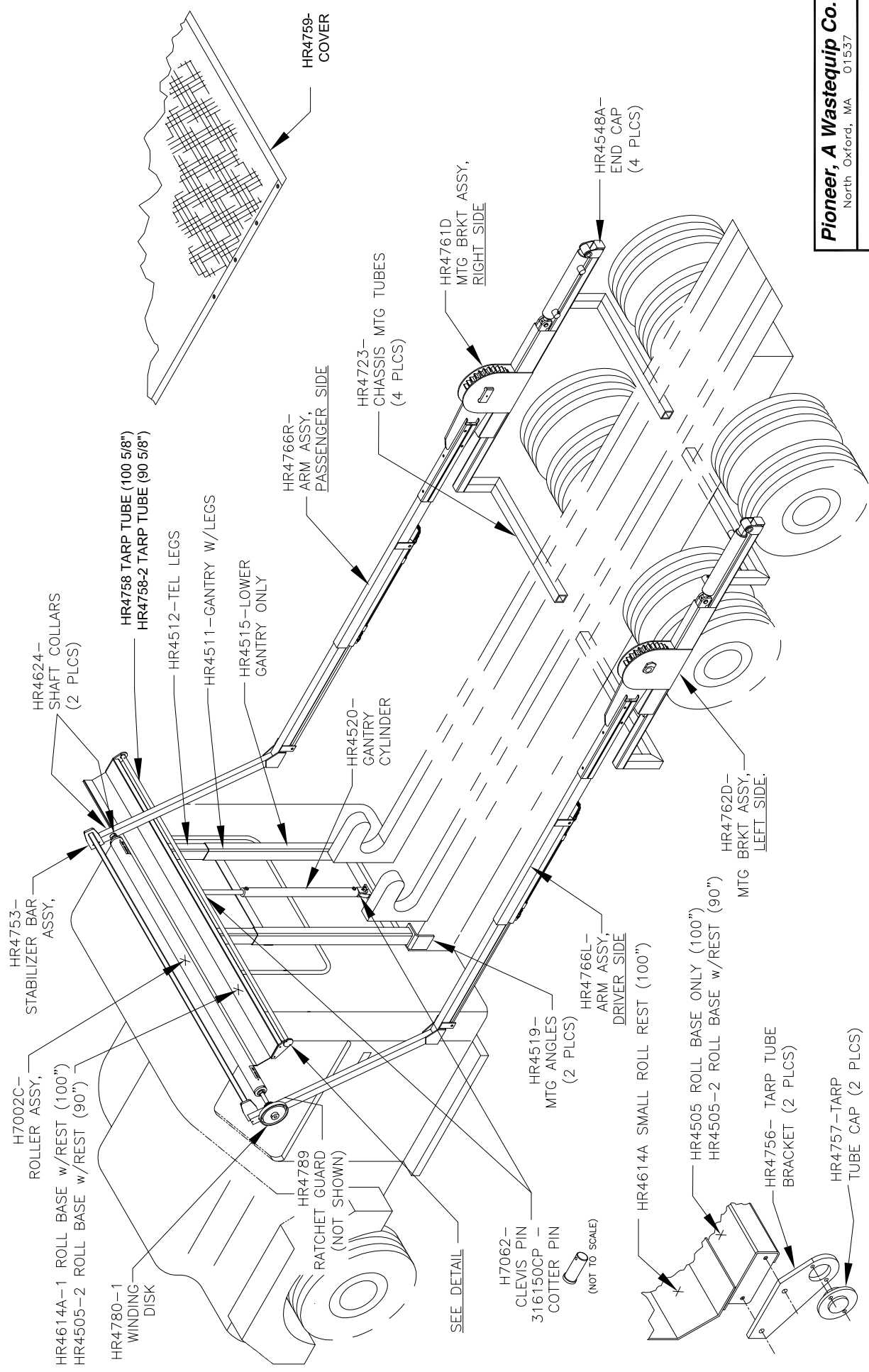

DETAIL

Pioneer, A Wastequip Co.
 North Oxford, MA 01537

RPSARG SCHEMATIC

PART NO. RPSARG SCHEMATIC

SCALE: NONE

DATE 4/25/07

DRW. BY: P.DOAN

REVISITONS

REV	DESCRIPTION	DATE	APPROVED
A	INITIAL RELEASE	04/25/2007	P. DOAN
B	REVISED	06/19/2007	P. DOAN
C	RACK 'N PINTON RE-DESIGN	03/12/2018	ARP

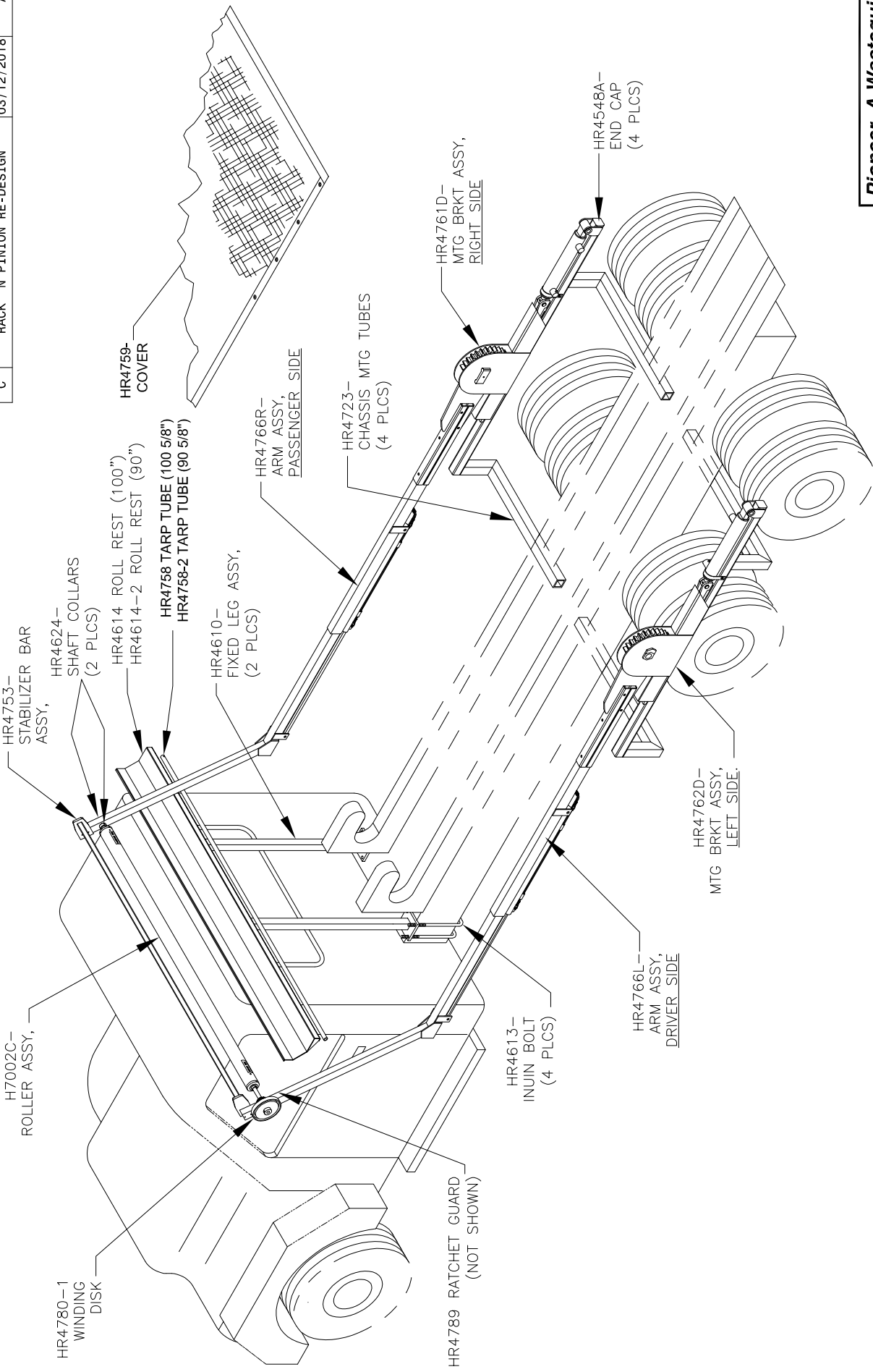

Pioneer, A Wastequip Co.
 North Oxford, MA 01537

RPSAR SCHEMATIC

PART NO. RPSAR SCHEMATIC DATE
 SCALE: NONE DRW. BY: P.DOAN 4/25/07

REVISIONS

REV	DESCRIPTION	DATE	APPROVED
A	INITIAL RELEASE	04/25/2007	P. DOAN

DRIVER SIDE

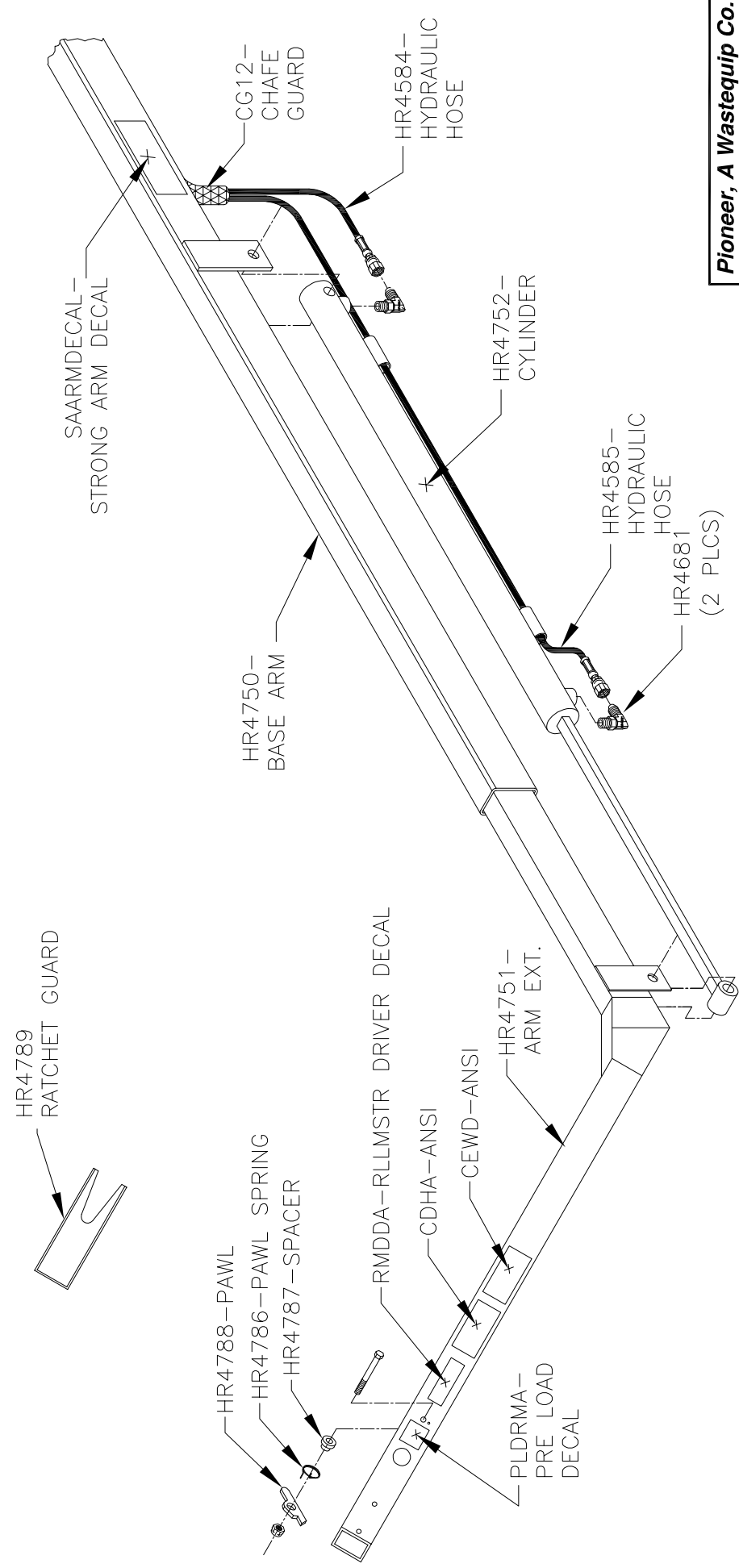

Pioneer, A Wastequip Co.
 North Oxford, MA 01537

SA ARM L.S.

PART NO.	HR4766L	DATE	4/25/07
SCALE:	NONE	DRW. BY:	P. DOAN

REVISTIONS

REV	DESCRIPTION	DATE	APPROVED
A	INITIAL RELEASE	04/25/2007	P. DOAN

PASSENGER SIDE

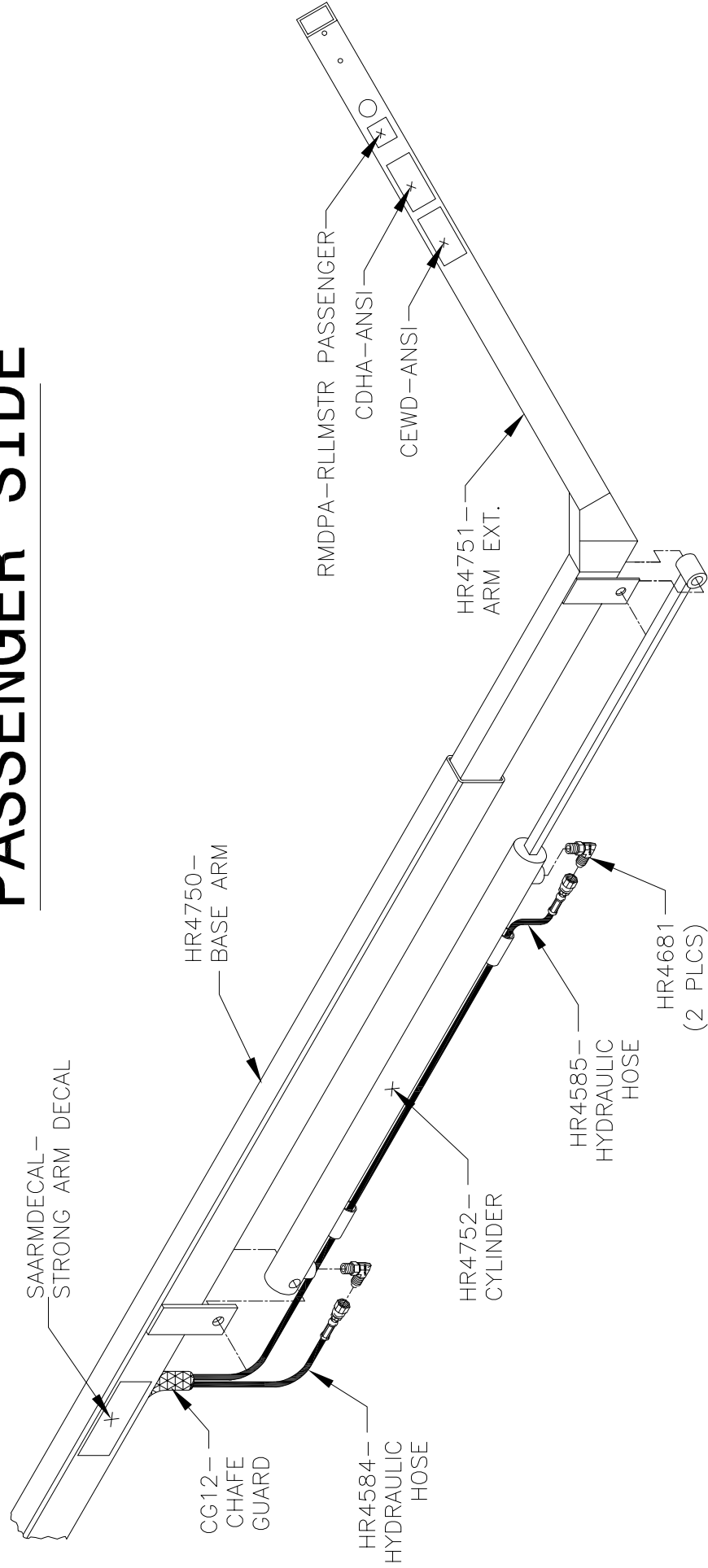

Pioneer, A Wastequip Co.	
North Oxford, MA 01537	
SA ARM R.S.	
PART NO.	HR4766R
SCALE:	NONE
DATE	4/25/07
DRW. BY:	P. DOAN

REVISIONS

REV	DESCRIPTION	DATE	APPROVED
A	INITIAL RELEASE	07/23/2007	P.DOAN

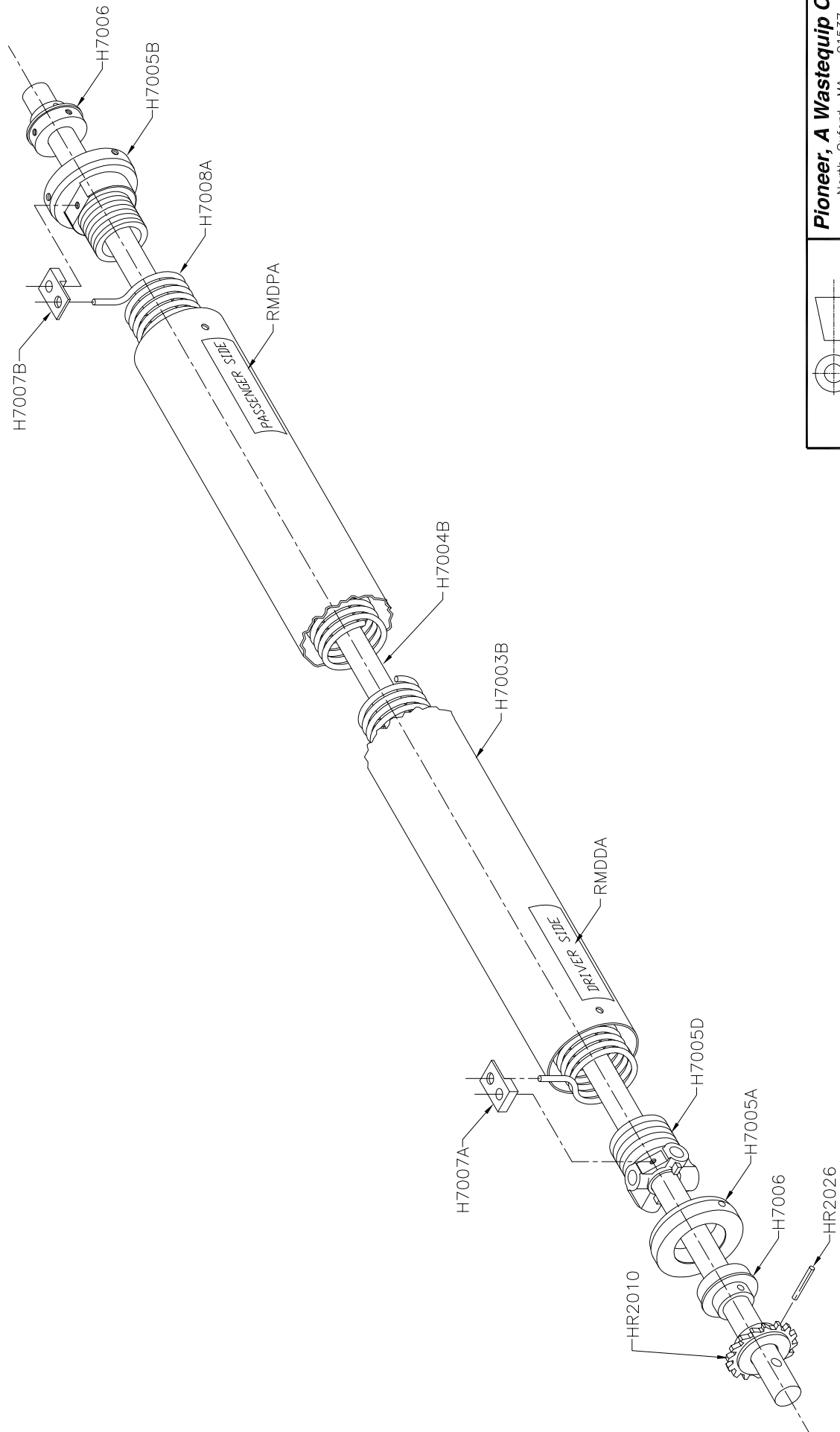

X = ±.030
 .XX = ±.015
 .XXX = ±.005
 ∠ = ± 2°

UNLESS OTHERWISE SPECIFY

Pioneer, A Wastequip Co.
 North Oxford, MA 01537
 H7002C ROLLER ASSY.
 PART NO. H2002C DATE
 SCALE: NONE DRAW. BY: P.DOAN 7/23/07

REVISTIONS

REV	DESCRIPTION	DATE	APPROVED
A	INITIAL RELEASE	04/23/2007	P.DOAN
B	RACK 'N PINION RE-DESIGN	03/12/2018	ARP

RIGHT SIDE

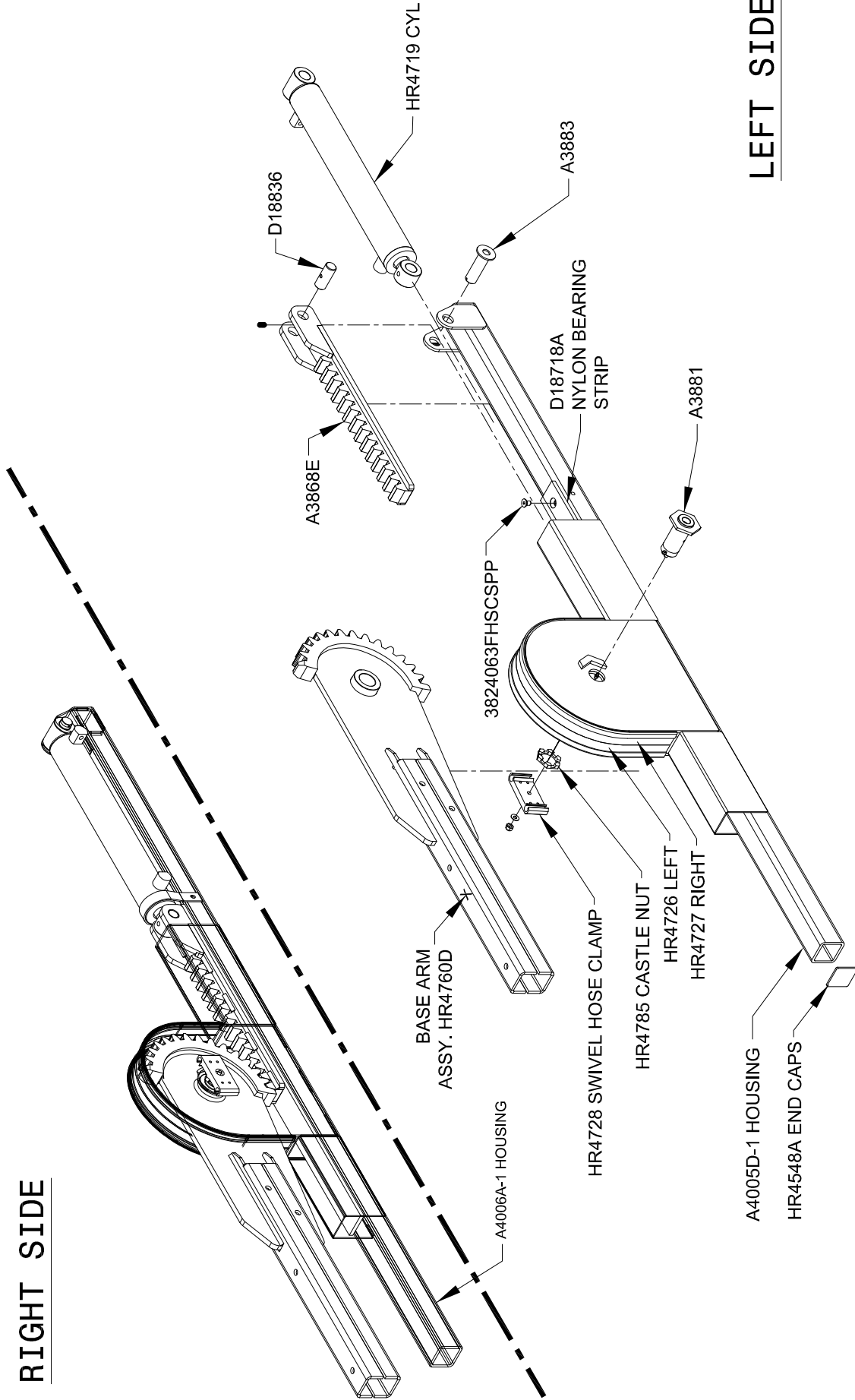

LEFT SIDE

NOTE:
A3881 & HR4785 CAN BE PURCHASED AS KIT# A3881 KIT.

Pioneer, A Wastequip Co.	
North Oxford, MA 01537	
S.A. RACK AND PINION ASSY. LEFT & RIGHT	
PART NO. R&P PARTS DETAIL	DATE
SCALE: NONE	DRW. BY: P.DOAN 4/23/07

LEGAL



WARNING: In order to prevent damage, the tarp must always be left in the uncovered position when the truck is not in use for a period of more than 2 consecutive hours.



WARNING: All repairs and parts replacement should be undertaken by qualified technicians. The buyer assumes all risks and liabilities arising out of his or her repairs, modifications, or parts replacement on the original product.



WARNING: Inspect the tarp system before each use for fit, wear and damage. Check tarp system at regular intervals during use. Replace parts at first sign of damage or material wear. If you find anything upon inspection that cannot be corrected, do not use as severe injury could result.



WARNING: Do not operate vehicle until you are certain that the tarp system is properly installed and can be safely operated.



WARNING: Do not operate the tarping system while the vehicle is in motion and make sure the vehicle is clear of any obstructions (such as overhead wires).



CAUTION: Any piece of equipment can be dangerous, even deadly, if not used properly. You are responsible for the proper use of this product and the safe operation of any accessories or related equipment and vehicles. Common sense and caution cannot be built into the equipment and must be supplied by the operator.



CAUTION: If for any reason you do not understand all portions of these instructions and warnings, contact the company at the number listed herein for assistance. Do not use, or allow others to use, the tarp system until you (and others) fully understand its operation, these instructions and warnings. Manufacturer assumes no liability or responsibility for injury or damage caused by improper use or failure to read and follow all instructions and warnings.

RP4500SARG SYSTEM INSTALLATION

RP 4500 SARG

RACK 'N PINION ROLLMASTER WITH GANTRY

INSTALLATION INSTRUCTIONS

Read and understand these instructions completely before beginning the installation. Use these instructions with the drawings included to unpack, identify and familiarize oneself with the various components of the system.



REPLACE ALL WARNING LABELS WHEN THEY BECOME UNREADABLE.

This system is designed to be used with containers that are the same length, but have different side heights. Various length containers may be used with this system as long as the rear of each container ends up in the same place on the truck. Short stops or the like may have to be used if this situation exists.

Prior to installing the flow diverter and cover control valve into your truck's hydraulic system, we recommend that you check with the hoist manufacturer for possible warranty implications.

RP4500SARG SYSTEM INSTALLATION

1. MOUNTING THE GANTRY AND ROLL REST ASSEMBLY

A. Pick a suitable place on the chassis of the truck directly behind the cab to mount the Gantry and Roll Assembly. Clear away or re-route any hoses, cables etc. that may interfere with mounting the Gantry to the chassis. Locate and clamp two HR4519 Chassis Mounting Angles to the frame. You may turn these angles in over the chassis or out from the chassis depending on the chassis width of your truck.

Allow a minimum of 4-5" between the front of the gantry legs and the back of the cab. This will provide clearance for the Roller Assembly as it moves up and down vertically. The mounting angles must be in the exact same position on either side of the chassis. A good way to ensure this is to pick a bolt on either side of the rear suspension chassis mounts and use that as a reference point for locating the mounting angles. You may also choose to utilize brackets that are already bolted to the chassis and weld a channel, ½" plate or rectangular tube on top of these existing brackets. If you choose this method, the mount should be a minimum of 5" wide front to back and 40" wide and centered on the chassis frame rails.

The height of the mounting angles should be the same if placed directly on top of the chassis flanges. If not, the height can be checked by measuring each side or with a level (assuming the truck is level). Once the mounting angles have been properly located and clamped, they must be bolted to the chassis with ½" grade 8 hardware (not supplied). Four bolts are recommended on each side. Drill holes through the mounting angles and chassis and torque the bolts to the manufacturer's recommendation.

NOTE: Do not drill into the chassis top and bottom flanges or any closer to the flanges than the truck manufacturer did.

B. Use an overhead crane and set the HR4511 gantry assembly on top of the mount that you just fabricated. Note that the gantry leg with the Serial Number plate goes on the Driver's side of the truck. Square the gantry to the hoist and make sure that it is perpendicular to the truck frame. Before welding into place, double check that you have 4-5" of clearance between the front of the gantry legs and the back of the truck cab. This space will provide adequate space for the roll rest to traverse up and down. Once the HR4511 gantry is located, weld the gantry legs continuously around the base of each. Be sure to leave the water drain notch in the bottom of each gantry leg open. Fabricate and add front and rear gussets to stabilize the gantry and strengthen the mounting.

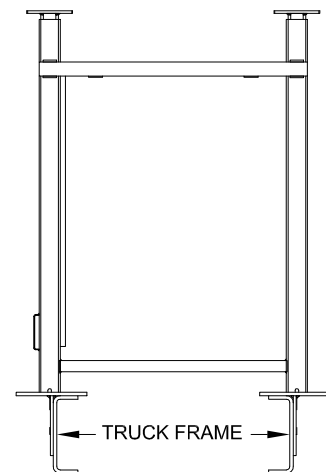

figure 1

RP4500SARG SYSTEM INSTALLATION

C. Safely lift the Roll Base/Rest Assembly on top of the HR4511 Gantry and install using four ½-13 hex nuts and lock washers provided. Install the HR4520 36" stroke gantry cylinder with the cylinder ports facing the driver's side of the chassis. Install one H7062 clevis pin and cotter pin (provided) thru each cylinder clevis and the eye pads on the gantry and roll rest. If the truck exhaust muffler/stack interferes with the roll rest at rest or as it travels upwards, you will need to check with the truck manufacturer before modifying it to clear the travel of the roll rest and taper arms that will be installed later.

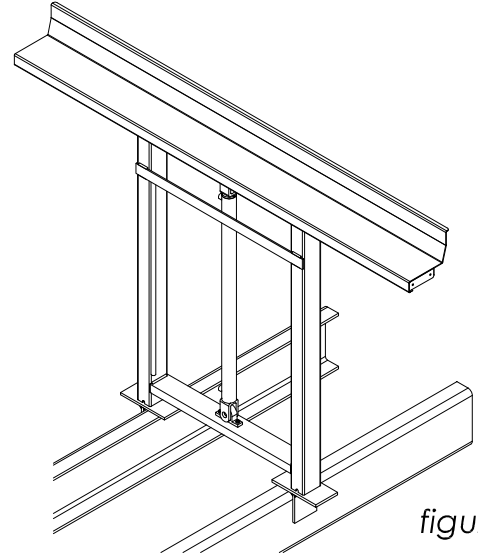

figure 2

2. LOCATING THE PIVOT POINT AND INSTALLING THE MOUNTING BRACKET ASSEMBLIES

The mounting bracket assemblies and taper arms must be mounted to a fabricated structure that is bolted to the truck chassis. This structure must extend outward from the chassis to allow for the widest width container that will be carried on the truck. We recommend that the Rack and Pinion side assemblies be mounted at 108" OD when measuring to the outside of pivot pin anti-rotation chevron.

Note that you should check to make sure that you do not have State or local regulations that differ from the Federal D.O.T. that sets a maximum width for safety devices of 108". If your local and State width requirements are less than the Federal, you must install this device to meet the most stringent of the applicable requirements.

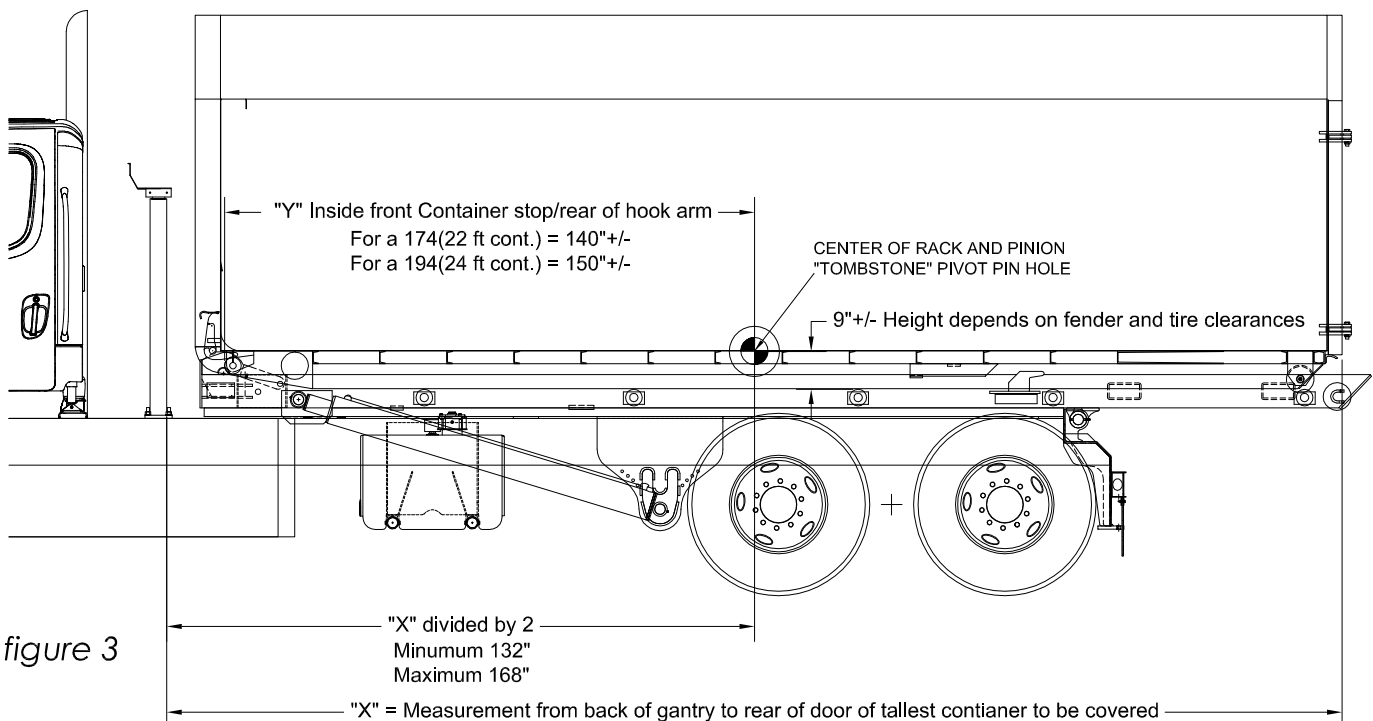

figure 3

RP4500SARG SYSTEM INSTALLATION

- A. To determine the pivot point of the versatile Rack and Pinion tarping system, you should determine the length of the tallest container to be covered. If you have it available, load it on to the hoist and measure the distance from the back of the gantry roll rest legs to the rear of the container door. This will be the ("X") dimension shown above. Divide ("X") by two and this will be the distance from the back of the gantry legs to the center of the tombstone pivot point.

Note that for a 174 cab to axle hoist (20-22' containers) the distance from the hoist front container stop (or rear of the Hook Lift "L" arm) to the center of the Rack and Pinion pivot will be approximately 140". For a 194 cab to axle hoist (22-24' containers) the distance from the front container stop to the center of the Rack and Pinion pivot will be approximately 150".

NOTE: The Rack and Pinion arm assembly has a maximum extended length of 168" from the center of the arm pivot to the center of the tarp roller assembly.

- B. Supplied with your system to make installation easier are four HR4723 chassis mounting tube assemblies. These are made longer in both directions than you may need so you can cut them to fit your installation. The HR4723 chassis mounting brackets are typically also used for mounting the fenders to the truck. So fore and aft placement can be adjusted to best fit your installation as long as they front and rear HR4723 fall under the Rack and Pinion side assembly.

CAUTION: Be sure to not install the HR4723 chassis mounting brackets in a location that will interfere with the movement of the hydraulic lift cylinders of the hoist.

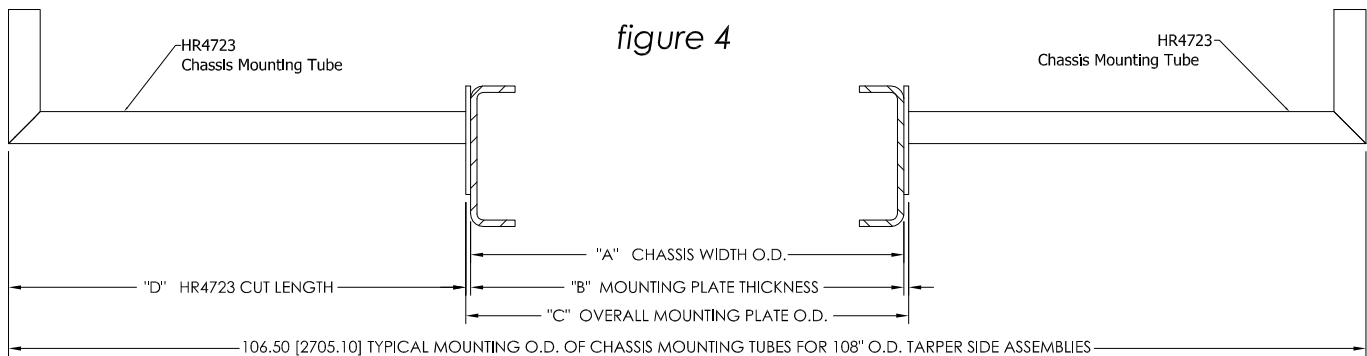

To determine the length ("D") of the longest leg of the HR4723, measure the outside width ("A") of your chassis, the width ("B") of the mounting plates on each side and add these together to get the overall width ("C"). Subtract ("C") from 106-1/2" and then divide this measurement by 2 to determine the length ("D") of the longest leg of the chassis mounting tubes.

EXAMPLE: Chassis width outside to outside ("A") = 33-1/2"
 Thickness of Mounting Plates ("B") = 3/8"
 Overall width at Mounting Plates ("C") = 33-1/2" + 3/8" + 3/8" = 34-1/4"
 106-1/2" - ("C") 34-1/4" = 72-1/4"
 HR4723 Longest Leg Dimension ("D") = 72-1/4" divided by 2 = 36-1/8"

RP4500SARG SYSTEM INSTALLATION

- C. The vertical height of the HR4761D and HR4762D Rack and Pinion Assemblies is determined by placing a straight edge across the hoist rails and measuring down to the bottom of the top lip of the fenders.

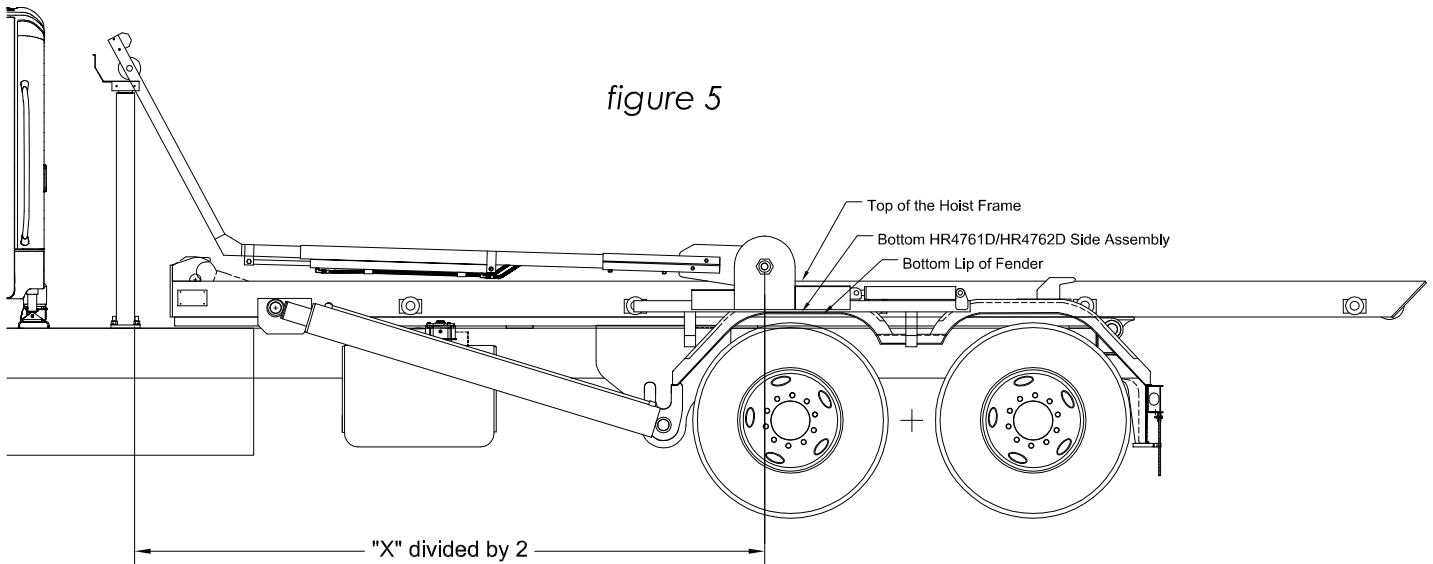

The bottom of the HR4761D and HR4762D Rack and Pinion assemblies cannot be mounted any lower than the bottom of the lower fender lip to allow clearance for tire changing. Measure from the bottom of the straight edge across the hoist frame rails down to the bottom of the fender and record this measurement. Tack weld the HR4723 chassis mounting brackets in place making sure they are plumb and square to the hoist. A good "Rule of Thumb" to use for setting the height of these is to mount them at the height needed for adding a fender mounting plate. The HR4723 will need a pair of gussets per mounting bracket custom fit to work for your installation. Using the straight edge across the hoist frame rails, measure down from the bottom of the straightedge the distance measured above. Mark the vertical leg of the HR4723 chassis mounting brackets and cut the excess off of the top. Place a HR4761D or HR4762D Rack and Pinion assembly on top of these tubes and align the center of the tombstone arm pivot pin (grease fitting) with the pivot point distance ("X" divided by 2) determined above. Find a place on the hoist to measure the HR4723 mounting brackets on both sides to make sure they are parallel with each other and the same distance from the front of the hoist. Plumb the HR4761D/HR4762D Rack and Pinion assemblies vertically and tack weld in place.

Check to make sure the HR4761D/HR4762D Rack and Pinion Assemblies are straight and parallel to the hoist. If not, correct by moving the Rack and Pinion Assemblies in and out as necessary. Be sure that the overall outside dimension of the Rack and Pinion Assemblies does not exceed 108" when measured at the widest point. This will usually be the head of the A3881 Arm Pivot Pins. A good way to make certain that the pivot pins are in the same location on both sides of the truck is to measure on a diagonal from the roll base/rest to the arm pivot pins.

RP4500SARG SYSTEM INSTALLATION

Before the final welding, measure side to side across the truck to make certain you are no wider than 108" from the outer most point of the head of the pivot pin to the opposite pivot pin. Correct as necessary. Add two gussets to each HR4723 chassis mounting bracket between the HR4723 and the steel fender mounting plates bolted to the truck frame. One gusset positioned to the front and one to the rear of the HR4723 to support for up and down movement as well as front to rear movement. Weld everything securely.

SOME POINTS TO REMEMBER ARE:

- **DO NOT WELD DIRECTLY TO THE CHASSIS.** Use Steel "Fish Plates/Fender Mounting Plates" that have been drilled and bolted to the chassis. Follow the chassis manufacturer's recommendations. **Do not** use any hardware below a grade 8.
- Make sure the structure is well supported and gusseted.
- There cannot be any flexing of the supports that hold the Rack and Pinion assemblies.

The HR4761D/HR4762D Rack and Pinion side assemblies must be:

- Plumb (vertically) and level (horizontally).
- Parallel to the chassis and set with a maximum width of 108" O.D.
- High enough to allow access to the tires.
- The same distance out from the chassis on both sides of the truck.

3. INSTALLING THE TARP, ROLLER, AND ARMS

Note: The tarp will come already anchored and rolled up onto the H7002 Roller Assembly with a new system. Should you need to install the tarp with the roller off of the tarper arms, use the instructions below:

A. Spread the tarp out on the ground with the Reinforced Side down. The tarp has a pocket at one end for anchoring to the roll rest with the HR4756 tarp tube brackets and HR4757 caps (figure 6).

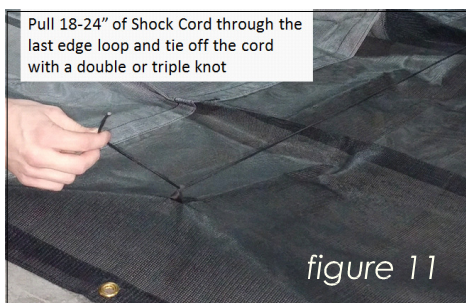
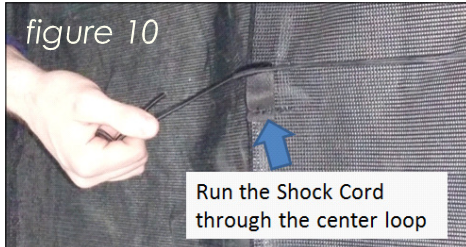
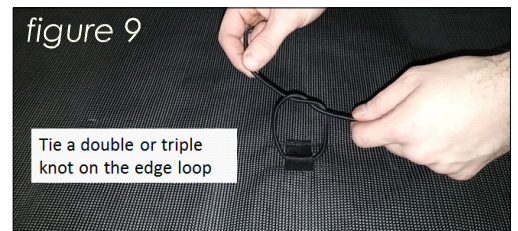
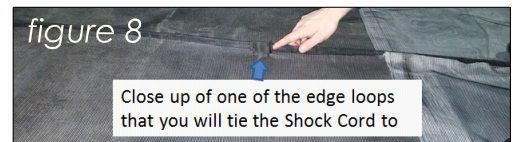
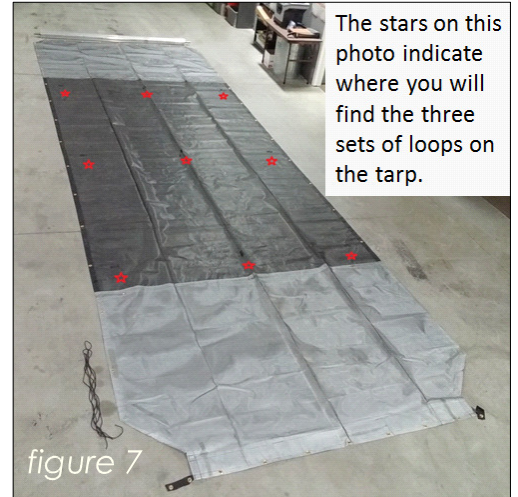

figure 6

RP4500SARG SYSTEM INSTALLATION

B. There are three sets of loops on the top of the tarp and three pieces of "shock cord" are provided with each tarp. The "shock cord" is a bungee cord type of rope. The cord needs to be installed side to side through each set of loops on the tarp for the tarp to roll up correctly (*figure 7*).

Tie a knot in either of the loops at the edge of the tarp, it does not matter which side you start with (*figures 8 and 9*).



Next, thread the shock cord through the center loop in the tarp (*figure 10*).

Now we need to run the free end of the shock cord through the edge loop and pull 18-24" through the loop and tie off with a double or triple knot.

NOTE: If you want to test the tension of the shock cords by covering a roll off container after installing the tarp roller and tarp assembly on your system, only put a single knot in the shock cord at this time.

RP4500SARG SYSTEM INSTALLATION

C. Place the H7002 Spring Loaded Roller Assembly on top of the tarp, opposite the end with the pocket, making sure the roller is properly oriented. The DRIVERS SIDE of the roller (marked with decals) is on the left side of the tarp and the PASSENGERS side is on the right side of the tarp when looking at the tarp from the end where you have placed the roller (figure 13).



figure 13



figure 14

Attach the tarp to the roller using nine 3/8" x 1" hex head bolts with 3/8" flat washers provided (figure 14). **Start attaching the tarp to the roller by aligning the middle grommet of the tarp with the middle of the aluminum roller. Work your way outward from the center on both sides and continue to attach the tarp to the roller using the bolts and washers provided.**

D. Roll the tarp onto the roller by rolling the roller tube itself over the tarp to the free end, making sure the excess tarp is folded on the bottom of the tarp as shown below. The tarp cannot be any wider than the roller for installation purposes and it must be wound evenly onto the roller.



figure 15

RP4500SARG SYSTEM INSTALLATION

E. Place the Roller, with the tarp attached, on top of the Roll Base/Rest with the DRIVERS side of the roller on the DRIVERS side of the truck, so that 6-8" of tarp hangs down below the rear of the ROLL BASE/REST. The DRIVERS side of the roller has a 3/8" hole drilled through the shaft. Attach the two HR4756 Tarp Tube Mounting Brackets to the roll base using 3/8 x 1" bolts and lock washers (provided). Insert the Tarp Tube through the tarp pocket and then secure the tarp with two 7/16 x 2-1/2" bolts, flat washers, lock washers, and hex nuts (provided) at either side of the tarp. Install the Tarp and tube into the brackets and secure in place with two HR4757 Tarp Tube Caps to the HR4756 brackets with the 1/4 x 1" bolts, lock washers and hex nuts (provided).

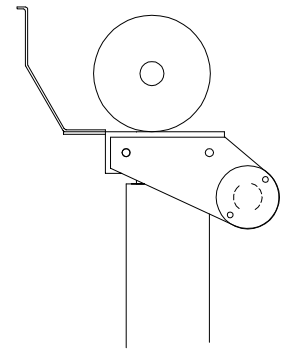

figure 16

F. Lift the DRIVERS side arm up and slide the base end of the arm into the HR4760D Base Arm/Gear Assembly. Carefully guide the two hydraulic hoses that stick out from the bottom of the arm between the large plate and the channel shaped pieces. The hoses MUST go on the inside of the Mounting Bracket Assemblies. Bolt the Arm to the Base Arm/Gear Assembly using two 1/2-13 x 3 1/4" long bolts, lock washers and nuts (provided) for the horizontal holes and two 1/2-13 x 4 1/2" long bolts, lock washers and nuts (provided) for the vertical hole. Tighten securely. Slide the 1" diameter hole in the Arm Extension onto the roller shaft making sure the pawl engages properly with the saw tooth gear. You will have to manually extend the arm in order to do this. Temporarily, install one 3/8-16 x 3" long bolt into the holes in the arm and roller shaft.

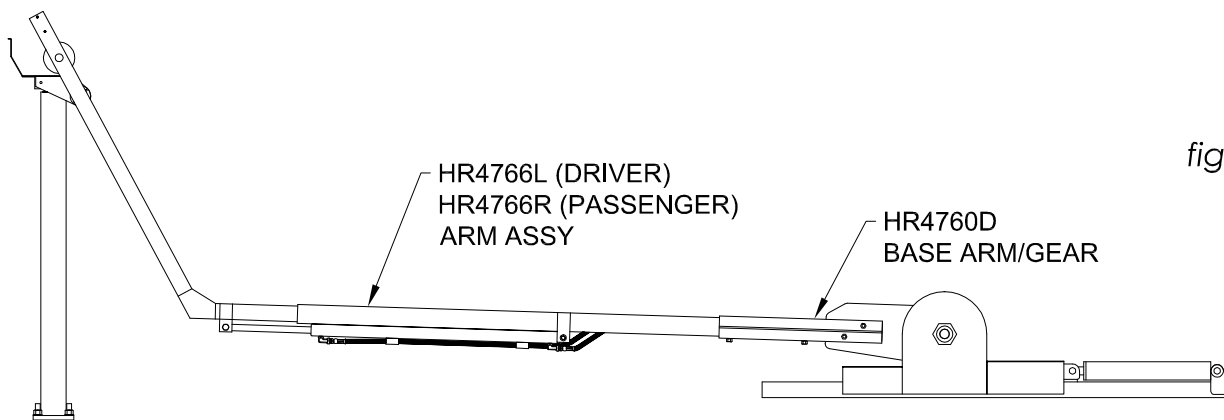

figure 17

G. Install the PASSENGERS side arm into the BASE ARM/GEAR ASSEMBLY in the same way as was done for the DRIVERS side arm. Before attaching the ARM EXTENSION to the roller shaft, slide one 1" ID SHAFT COLLAR onto the roller shaft. Slide the ARM EXTENSION onto the roller shaft as was done before and then slide one SHAFT COLLAR onto the roller shaft on the outside of the arm. Slide the roller assembly towards the drivers' side, to be sure that correct engagement between the saw tooth gear on the roller shaft, and the pawl (located on the arm extension) are properly engaged.

RP4500SARG SYSTEM INSTALLATION

- H. Install the *Stabilizer Bar*, making sure it is facing the REAR of the truck, between the arms using four 5/16-18 x 2 1/4" long bolts and locknuts (provided). Slide the two shaft collars on the PASSENGERS side of the roller shaft tight up against the arm forming a sandwich. The outboard shaft collar should be flush to the end of the shaft once the shaft has been moved towards the driver's side until the HR2010 Ratchet Gear on the roller shaft is firmly against the DRIVERS SIDE arm. Snug the setscrew in the outboard shaft collar and remove the setscrew from the inboard shaft collar. Hold the inboard shaft collar tight up against the arm, drill a small dimple in the shaft thru the setscrew hole using a 3/16 drill. Reinstall the setscrew into the collar using a threadlocker on the threads. Tighten securely so the setscrew "bites" into the dimple in the shaft. Repeat for the outboard shaft collar and setscrew.

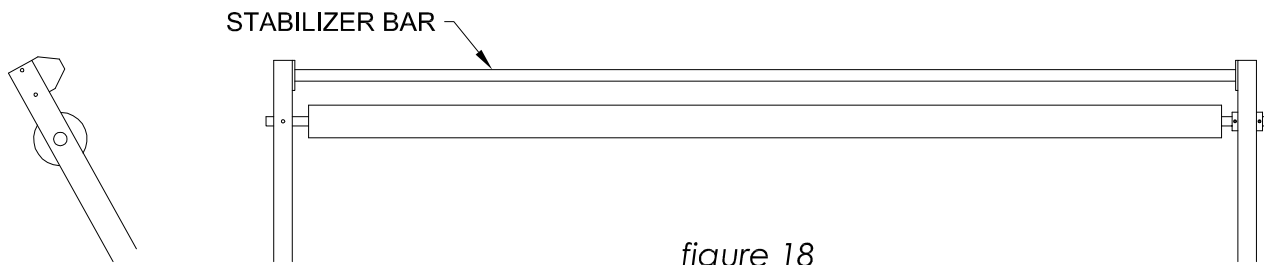

figure 18

- I. Install the Ratchet Guard onto the inside of the driver's side arm by loosening the locknuts and opening the "gate" to allow the guard to be slid over the saw tooth gear, pawl and shaft. Close the "gate", tighten the nuts and bolt the guard to the arm using the 5/16-18 x 3 1/2" HHCS and stover lock nut provided.
- J. Install the WINDING DISK (*figure 19*) onto the DRIVERS side roller shaft and tighten the setscrews. Remove the 3/8 bolt from the arm and shaft. Turn the WINDING DISK 7 revolutions in a counterclockwise direction as viewed from the driver's side. FOLLOW THE DECALS ON THE ARM and DISK.
- K. Hold onto the disk firmly while you are loading the spring. When you have reached 7 turns, stop and insert the 3/8 bolt thru the arm and shaft. Install the 3/8-16 stover lock nut onto the bolt and tighten securely. Remove the WINDING DISK from the shaft and put in a secure place in the truck.

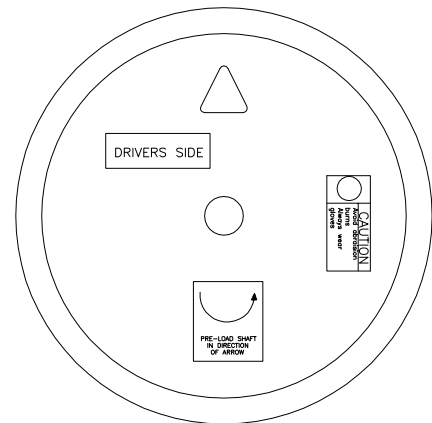

figure 19



WEAR GLOVES and DO NOT LET GO OF THE WINDING DISK UNTIL THE BOLT HAS BEEN INSERTED INTO THE ARM AND SHAFT.



ENSURE THAT THE SAFETY RATCHET PAWL ENGAGES THE SAW-TOOTH GEAR ON THE ROLLER SHAFT BEFORE WINDING!

RP4500SARG SYSTEM INSTALLATION

4. INSTALLING THE FLOW DIVERTER AND COVER CONTROL VALVE

NOTE: See Hydraulic Schematics on Pages 14-15.

NOTE: Filtration of 30 micron or better must be used with these components.

Select a suitable place for the Cover Control Valve that will allow for ease in operation while not interfering with the hoist, container or hoist controls. It is suggested that this valve be mounted on the driver's side of the truck directly behind the cab. This position will allow for safe and easy operation. In addition, if the hoist controls are located there, the operator can run both systems from the same location. Fabricate a mounting plate for the Cover Control Valve that will bolt to the chassis or weld to an existing bracket. Bolt the valve to the bracket using 5/16 grade 5 hardware (not provided).

A. The HR2062 Flow Diverter should be installed between the pump and the hoist main control valve. The Pioneer covering system requires 2 GPM of hydraulic flow which may adversely affect the hoist speed of operation. Pick a suitable location to mount the Flow Diverter. The flow diverter valve may be bolted to a bracket (not supplied) by the mounting holes in the bottom of the flow diverter manifold block.

NOTE: For hoist operating pressures greater than 3,800 psig, you must install the flow diverter valve downstream of the hoist valve using power beyond, or use the optional HR2068 Flow Diverter with a ductile iron valve body that is rated to 5,000 psig.

Hoses and fittings for connecting the diverter to the pump, the diverter to the hoist controls, the diverter relief valve port to the tank return line and the cover control valve to tank, are not supplied because of the many places these parts can be mounted.

NOTE: Use only pipe thread sealant such as RectorSeal on pipe threads.
DO NOT USE TEFLON TAPE!!!

Follow the HR4767-4B or HR4768-4C hydraulic schematic and connection between:

1. The pump to the flow diverter (IN port) #16 o-ring port.
2. From the diverter SYS port to the **hoist** control valve inlet #16 o-ring port.
3. From the diverter (REG- regulated flow port) to the **cover control valve** inlet #8.
4. From the diverter valve (T-port) to the tank return line #16 o-ring port.
5. From the **cover control valve** outlet to tank return line.

Hoses that are used to make these connections must be equivalent to the original equipment provided by the hoist manufacturer. Set the flow diverter valve relief valve 100 PSI higher than the hoist main relief valve setting. There is a (GP) gauge port in the diverter valve body that is plugged with an SAE number 4 o-ring plug that must be used to set the relief valve pressure.

HYDRAULIC SCHEMATIC FOR RP4500SARG WITH GANTRY (AFTER 04/2017)

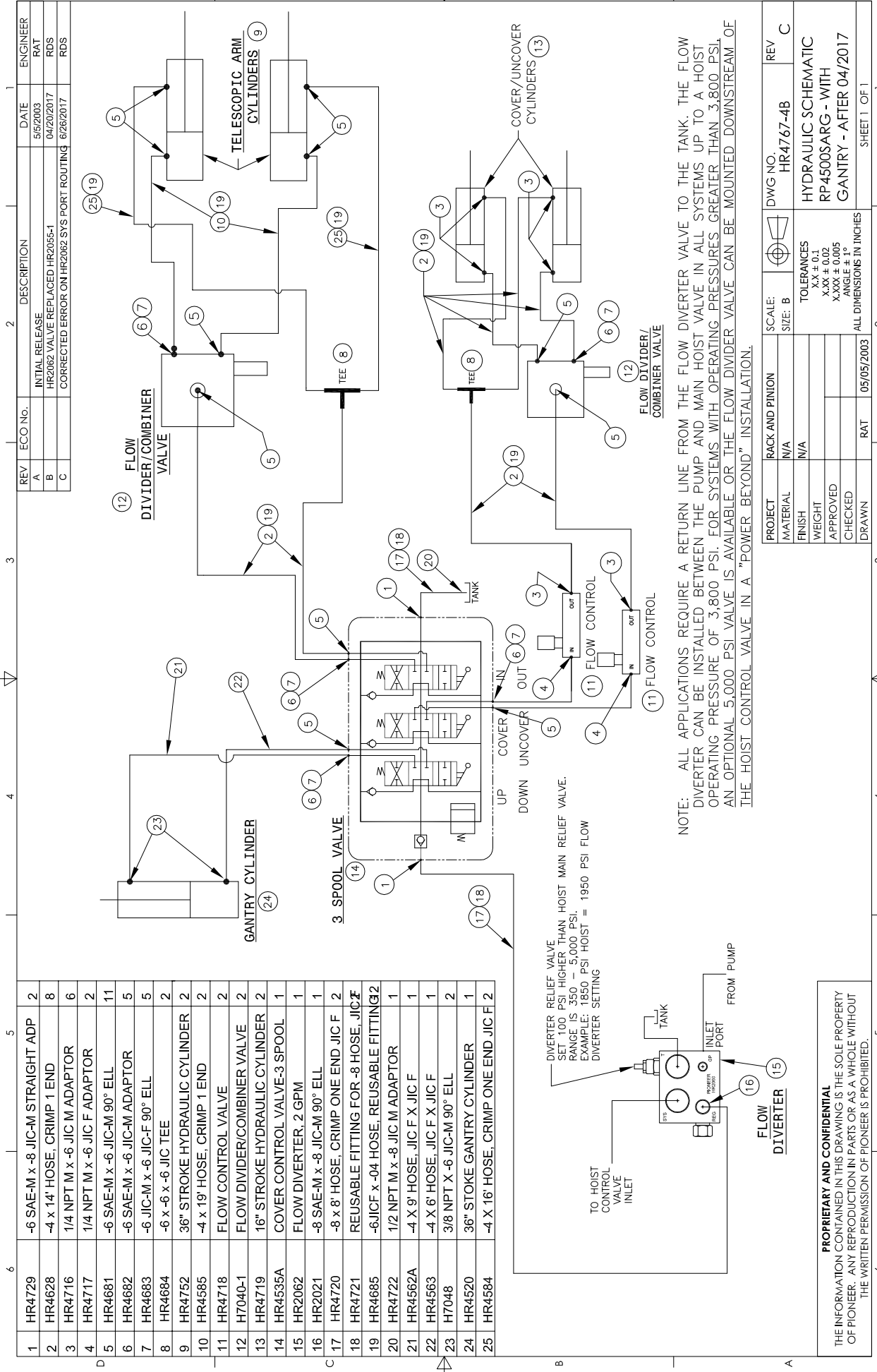

1	HR4729	-6 SAE-M x -8 JIC-M STRAIGHT ADP	2
2	HR4628	-4 x 14' HOSE, CRIMP 1 END	8
3	HR4716	1/4 NPT M x -6 JIC M ADAPTOR	6
4	HR4717	1/4 NPT M x -6 JIC F ADAPTOR	2
5	HR4681	-6 SAE-M x -6 JIC-M 90° ELL	11
6	HR4682	-6 SAE-M x -6 JIC-M ADAPTOR	5
7	HR4683	-6 JIC-M x -6 JIC-F 90° ELL	5
8	HR4684	-6 x -6 x -6 JIC TEE	2
9	HR4752	36" STROKE HYDRAULIC CYLINDER	2
10	HR4585	-4 x 19' HOSE, CRIMP 1 END	2
11	HR4718	FLOW CONTROL VALVE	2
12	HT040-1	FLOW DIVIDER/COMBINER VALVE	2
13	HR4719	16" STROKE HYDRAULIC CYLINDER	2
14	HR4535A	COVER CONTROL VALVE-3 SPOOL	1
15	HR2062	FLOW DIVERTER, 2 GPM	1
16	HR2021	-8 SAE-M x -8 JIC-M 90° ELL	1
17	HR4720	-8 x 8' HOSE, CRIMP ONE END JIC F	2
18	HR4721	REUSABLE FITTING FOR -8 HOSE, JIC F	2
19	HR4685	-6 JIC F x -04 HOSE, REUSABLE FITTING	2
20	HR4722	1/2 NPT M x -8 JIC M ADAPTOR	1
21	HR4562A	-4 X 9' HOSE, JIC F X JIC F	1
22	HR4563	-4 X 6' HOSE, JIC F X JIC F	1
23	H7048	3/8 NPT X -6 JIC-M 90° ELL	2
24	HR4520	36" STROKE GANTRY CYLINDER	1
25	HR4584	-4 X 16' HOSE, CRIMP ONE END JIC F	2

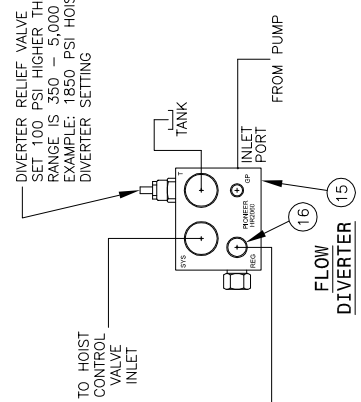

NOTE: ALL APPLICATIONS REQUIRE A RETURN LINE FROM THE FLOW DIVERTER VALVE TO THE TANK. THE FLOW DIVERTER CAN BE INSTALLED BETWEEN THE PUMP AND MAIN HOIST VALVE IN ALL SYSTEMS UP TO A HOIST OPERATING PRESSURE OF 3,800 PSI. FOR SYSTEMS WITH OPERATING PRESSURES GREATER THAN 3,800 PSI, AN OPTIONAL 5,000 PSI VALVE IS AVAILABLE OR THE FLOW DIVERTER VALVE CAN BE MOUNTED DOWNSTREAM OF THE HOIST CONTROL VALVE IN A "POWER BEYOND" INSTALLATION.

REV	ECO No.	DESCRIPTION	DATE	ENGINEER
A		INITIAL RELEASE	5/5/2003	RAT
B		HR2062 VALVE REPLACED HR2055-1	04/20/2017	RDS
C		CORRECTED ERROR ON HR2062 SYS PORT ROUTING	02/02/2017	RDS

PROJECT	RACK AND PINION	SCALE:	DWG NO.	REV
MATERIAL	N/A	SIZE: B	HR4767-4B	C
FINISH	N/A	TOLERANCES	HYDRAULIC SCHEMATIC	
WEIGHT		X.X ± 0.1	RP4500SARG - WITH	
APPROVED		X.XX ± 0.02	GANTRY - AFTER 04/2017	
CHECKED		X.XXX ± 0.005		
DRAWN	RAT	ANGLE ± 1°		
		ALL DIMENSIONS IN INCHES	SHEET 1 OF 1	

PROPRIETARY AND CONFIDENTIAL
THE INFORMATION CONTAINED IN THIS DRAWING IS THE SOLE PROPERTY OF PIONEER. ANY REPRODUCTION IN PARTS OR AS A WHOLE WITHOUT THE WRITTEN PERMISSION OF PIONEER IS PROHIBITED.

HYDRAULIC SCHEMATIC FOR RP4500SAR WITH FIXED-LEG GANTRY (AFTER 04/2017)

REV	ECO No.	DESCRIPTION	DATE	ENGINEER
A		INITIAL RELEASE	05/05/03	ENH
B		NEW ADAPTORS AND VALVE	06/07/07	ENH
C		HR2062 VALVE REPLACED HR2055-1	04/10/2017	RDS

1	HR4729	-6 SAE-M x -8 JIC-M ST ADP	2
2	HR4628	HYD HOSE, -4x12' CRIMP 1 END	8
3	HR4716	1/4 NPT M x -6 JIC M ADAPTER	6
4	HR4717	1/4 NPT M x -6 JIC F ADAPTER	2
5	HR4681	-6 SAE M x -6 JIC M 90° ELL	10
6	HR4682	-6 SAE M x -6 JIC M ADAPTER	4
7	HR4683	-6 JIC M x -6 JIC F 90° ELL	4
8	HR4684	-6 x -6 x -6 JIC TEE	2
9	HR4752	HYD CYLINDER, 36" STROKE	2
10	HR4585	HYD HOSE -4x19' CRIMP 1 END	2
11	HR4718	FLOW CONTROL NEEDLE VALVE	2
12	HR7040-1	FLOW DIVIDER/COMBINER VALVE	2
13	HR4719	HYD CYLINDER, 16" STROKE	2
14	HR4535	COVER CONTROL VALVE-2 SPOOL	1
15	HR2062	FLOW DIVERTER - 2 GPM	1
16	HR2021	-8 SAE M x -8 JIC 90° ELL	1
17	HR4720	-8 HOSE x 8' L, CRIMP 1 ENDS	2
18	HR4721	REUSABLE FITTING FOR -8 HOSE	2
19	HR4685	REUSABLE FITTING FOR -4 HOSE	12
20	HR4722	1/2 NPT M x -8 JIC M ADAPTOR	1
21	HR4584	16" HOSE, CRIMP 1 END, -4 JIC	2

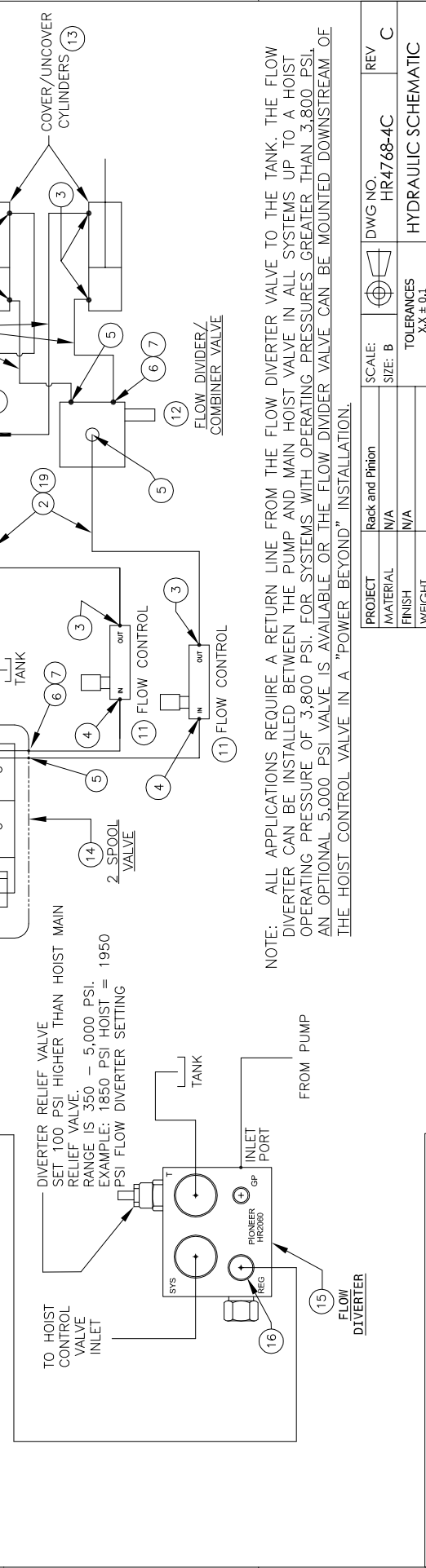

NOTE: ALL APPLICATIONS REQUIRE A RETURN LINE FROM THE FLOW DIVERTER VALVE TO THE TANK. THE FLOW DIVERTER CAN BE INSTALLED BETWEEN THE PUMP AND MAIN HOIST VALVE IN ALL SYSTEMS UP TO A HOIST OPERATING PRESSURE OF 3,800 PSI. FOR SYSTEMS WITH OPERATING PRESSURES GREATER THAN 3,800 PSI, AN OPTIONAL 5,000 PSI VALVE IS AVAILABLE OR THE FLOW DIVIDER VALVE CAN BE MOUNTED DOWNSTREAM OF THE HOIST CONTROL VALVE IN A "POWER BEYOND" INSTALLATION.

PROJECT	Rack and Pinion	SCALE:	DWG NO.	REV
MATERIAL	N/A	SIZE: B	HR4768-4C	C
FINISH	N/A	TOLERANCES	HYDRAULIC SCHEMATIC	
WEIGHT		X.X ± 0.1	RP4500SAR-FIXED GANTRY	
APPROVED		X.XX ± 0.02	AFTER 04/2017	
CHECKED		X.XXX ± 0.005		
DRAWN	RAT	ANGLE ± 1°		
		ALL DIMENSIONS IN INCHES	SHEET 1 OF 1	

PROPRIETARY AND CONFIDENTIAL
 THE INFORMATION CONTAINED IN THIS DRAWING IS THE SOLE PROPERTY OF PIONEER. ANY REPRODUCTION IN PARTS OR AS A WHOLE WITHOUT THE WRITTEN PERMISSION OF PIONEER IS PROHIBITED.

RP4500SARG SYSTEM INSTALLATION

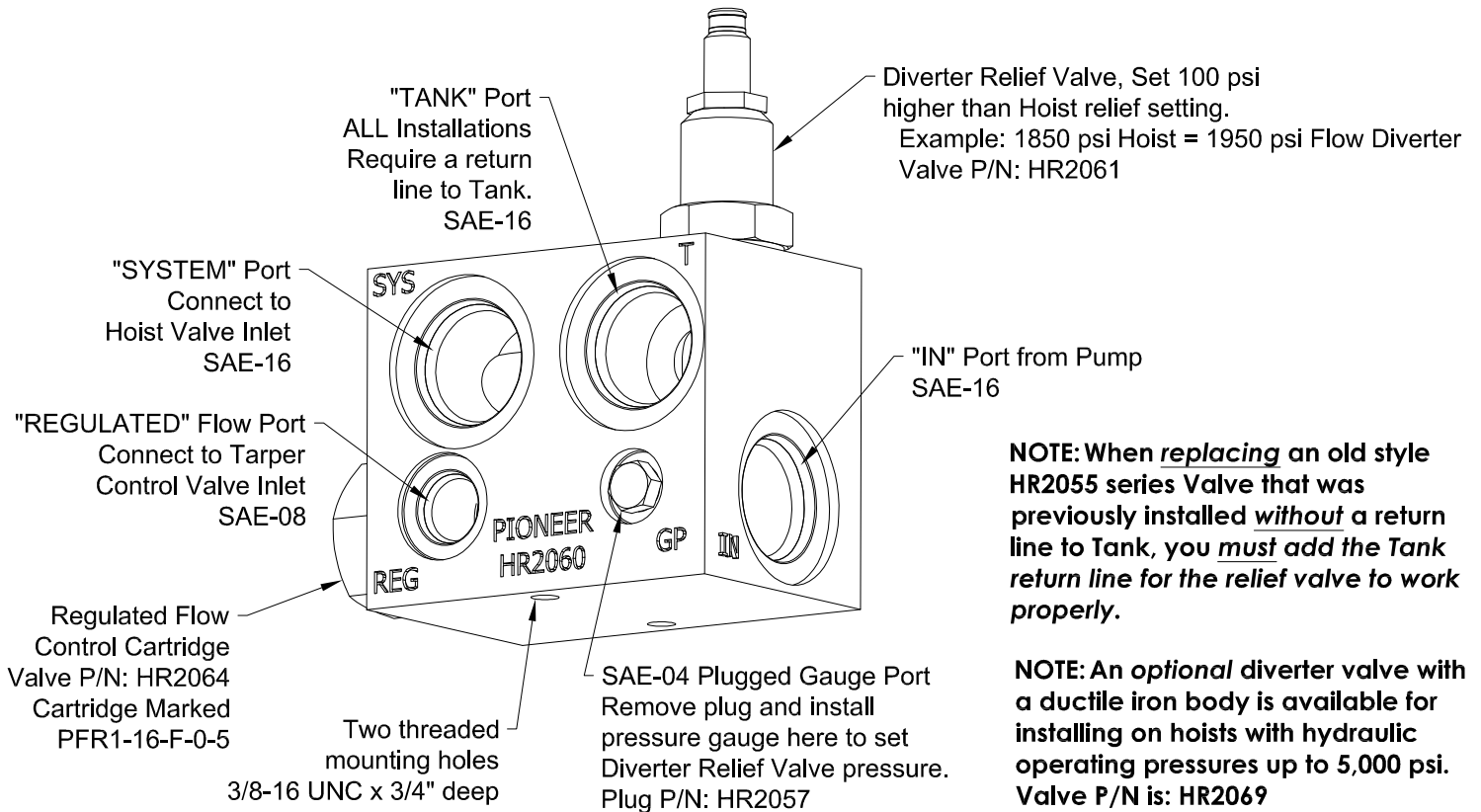

PIONEER TARP SYSTEMS WORKING PRESSURES

*(Does not include High Pressure Hoist. For High Pressure Hoists, see **page 23**)*

RP4500SAR = 1850psi to 1950psi

RP4500SARG = 1850psi to 1950psi

RP4500SATR = 1850psi to 1950psi

HR1500PTO = 900 psi to 1000 psi (MAX)

HR1500H = 900 psi to 1000 psi (MAX)

HR2000PTO = 900 psi to 1000 psi (MAX)

HR1000PTO = 900 psi to 1000 psi (MAX)

Systems that use a Hydraulic Motor must be **under 1000psi** or seal damage may happen.

HR1500PTO, HR1500H, HR1000PTO, and HR2000PTO must be set to **less than 1000psi**.

Warranty will be void on Hydraulic motors with systems set higher than 1000psi.

RP4500SARG SYSTEM INSTALLATION

HIGH PRESSURE POWER BEYOND DIVERTER INSTALLATION **FOR USE WITH HOISTS WITH OPERATING PRESSURES GREATER THAN 3,800 PSI**

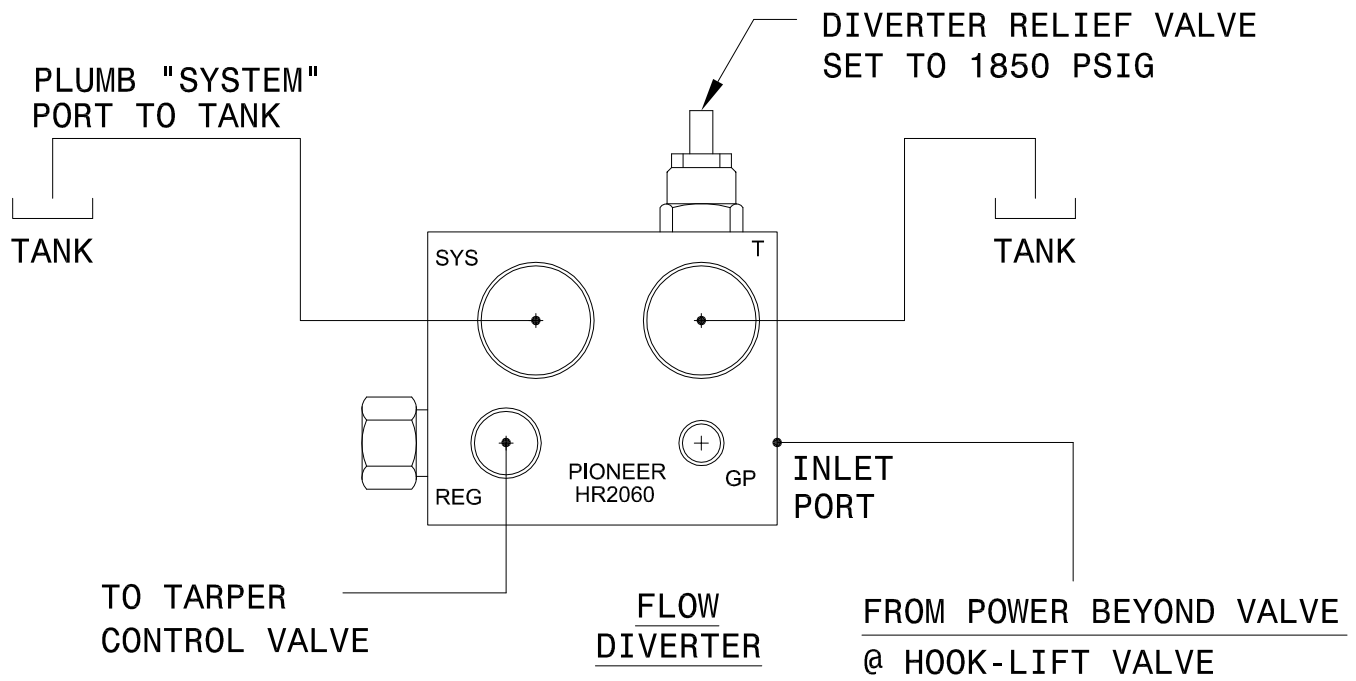

NOTE: SCHEMATIC SHOWN FOR ALL HIGH PRESSURE POWER BEYOND INSTALLATIONS FOR THE HR2062 OR HR2065 FLOW DIVERTER VALVES.

THIS INSTALLATION REQUIRES ***BOTH*** THE "SYSTEM" PORT AND THE "TANK" PORTS TO BE PLUMBED TO THE TANK RETURN LINE.

THE "INLET " PORT IS SUPPLIED BY YOUR POWER BEYOND VALVE AT YOUR HOIST CONTROL VALVE.

THE "REG" REGULATED FLOW PORT IS CONNECTED TO YOUR TARP CONTROL VALVE INLET.

RP4500SARG SYSTEM INSTALLATION



Follow the appropriate hydraulic schematic for your installation and install the proper fittings and hoses to the gantry lift cylinder, flow divider/combiners and cover control valve.

The hoses furnished with this system all have reusable ends to allow you to custom fit the hoses for your installation. These ends will be installed once the hoses have been installed.

NOTE: IF THE HOSES ARE CUT, BLOW THEM OUT WITH COMPRESSED AIR TO REMOVE ANY HOSE FILINGS OR PARTICLES WHICH MAY CONTAMINATE THE SYSTEM.

B. Plumb the Gantry Lift by attaching one 9' hose to the rod end fitting on the cylinder and attach one 6' hose to the base end fitting on the cylinder. The valve section labeled "UP - DOWN" is used to control the vertical motion of the gantry with the fittings indicated in the schematic. Route the hoses from the gantry cylinder toward the Cover Control Valve using nylon zip ties or clamps to secure the hoses along the way. Connect the hoses to the elbows on top of the valve. At this point it doesn't matter which hose goes to which side of the valve. They can be swapped later on.

C. COVER-UNCOVER Function ONLY. Connect two HR4718 Flow Control valves to the COVER-UNCOVER valve section as shown in the photo above. The **inlet** side of the HR4718 Flow Control is stamped with the letter "B".

D. Install four 14' long hoses onto the Cover Control Valve (two for COVER-UNCOVER and two for IN & OUT) per the schematic. Run these four hoses down along the chassis toward the rear using wire ties, etc. to attach them to stationary objects along the way. Mark or identify the hoses in some fashion so you will not cross the lines when making the connections. In the area where the hoses end, you will need to mount the two Flow Divider/Combiner valves.

RP4500SARG SYSTEM INSTALLATION

- E. Install the H7040-1 Flow Divider/Combiner valves in a suitable place on the chassis. They should be situated as close to the taper Mounting Bracket Assemblies (front to rear location) as possible. They can be mounted to a non-moving hoist cross member (sub frame) or to a plate that is attached to a chassis cross member. Install using 1/4" hardware (not provided). Install the reusable fittings on the four hoses and connect to the Flow Divider/Combiners and HR4684 Tee per the schematic. **DO NOT CROSS THE LINES.**
- F. The hoses attached to the telescoping arm cylinders have been pre-assembled to the cylinders and arms at the factory. Identify and mark the 16' long hose, and the 19' long hose connected to the Arm Extension Cylinders. **DO NOT CROSS THESE LINES.** Slide the loose ends of both arm extension hoses thru the HR4728 Swivel Hose Clamps on the inside of the Rack and Pinion tombstone pivot assembly. Route these hoses toward the Flow Divider/Combiners, install the reusable hose ends and make the connections to the Flow Divider/Combiner and HR4684 Tee per the schematic.
- G. Attach the four remaining hoses to the 16" Rack and Pinion cylinders and route toward the Flow Divider/Combiner valve. Install the reusable ends and make the connections to the Flow Divider/Combiner valve and HR4684 Tee as per the schematic.

NOTE: HOSE LENGTHS AND FITTINGS ARE CRITICAL.

EXAMPLE:

HOSES THAT RUN FROM THE FLOW DIVIDER/COMBINER TO THE BASE END OF THE CYLINDERS MUST BE THE SAME LENGTH. IN ADDITION, THE FITTINGS COMING OUT OF THE FLOW DIVIDER/COMBINER MUST BE THE SAME. (i.e. both straight or both elbows). THE SAME HOLDS TRUE FOR THE FITTINGS ON THE CYLINDERS.

NOTE: THE BASE END PORTS OF THE CYLINDERS MUST BE CONNECTED TO A FLOW DIVIDER/COMBINER AND THE ROD END PORTS MUST BE CONNECTED TO THE TEE. THE SYSTEM WILL NOT WORK PROPERLY IF THESE LINES ARE CROSSED. IT WILL ALSO CAUSE DAMAGE TO THE SYSTEM AND PRESENTS A POSSIBLE SAFETY HAZARD.

- H. Make certain that all connections are made per the Hydraulic Schematic and the return lines are connected to the tank. Use nylon cable ties to fasten the hoses to each other and to stationary objects along the way to make a neat installation. If any chafe points are evident, slip a large piece of hose or chafe guard over the hose(s) at the chafe point and secure.
- I. Using a pressure gauge, set the **pressure relief valve** on the Flow Diverter to 100 PSI **higher** than the hoist relief valve setting. Example: Hoist Relief is set to 2500 PSI. Set the flow diverter relief valve to 2600 PSI. This can be done by "deadheading" the tilt frame lift cylinders in a down position.

RP4500SARG SYSTEM INSTALLATION

- J. We are now ready to bleed the air out of the hydraulic system. Start the truck and engage the PTO to activate the hydraulic system. Operate the COVER-UNCOVER valve to make the arms move toward the rear (COVER). This will lift the arms and roller assembly upwards off of the roll rest. Go up only a few feet and stop. Operate the valve to move the arms downwards so that the roller assembly is sitting on the roll rest again (UNCOVER). Hold the valve handle for a few seconds to force the relief to open and then return the valve handle to the center position. Crack open the fittings at the base end of the cylinders to let any air escape that may be trapped inside. Re-tighten the fittings and run the system (UNCOVER) so the stabilizer bar is resting on the top rear of a container, or the arms are fully rearward if there is no container available. Hold the valve handle for a few seconds to force the relief to open. Crack open the fittings at the rod end of the cylinders to let any air escape that may be trapped in that end of the cylinders. Re-tighten the fittings and repeat this process until ALL air is removed from the cylinders, hoses and valves. Check to make sure the unit "COVERS" when the valve handle is moved in that direction. If not, the hoses are reversed. Correct as necessary.



NOTE: DO NOT ALLOW THE ARMS TO GO OVER "CENTER" UNTIL THE CYLINDERS ARE FILLED WITH OIL. IF THEY ARE ALLOWED TO GO OVER "CENTER" YOU WILL NOT BE ABLE TO CONTROL THEIR DOWNWARD MOVEMENT WHICH COULD CAUSE DAMAGE TO THE UNIT OR PERSONAL INJURY.



NOTE: IF THE ARMS WILL NOT MOVE UPWARD FROM THE ROLL REST, YOU WILL HAVE TO ADJUST THE PRESSURE RELIEF ON THE COVER CONTROL VALVE. REMOVE THE CAP AND TURN THE ADJUSTING SCREW 1/4 OF A TURN CLOCKWISE AND TRY THE SYSTEM. REPEAT UNTIL THE ARMS MOVE SMOOTHLY AND IN UNISON.



NOTE: THERE IS A CROSS OVER RELIEF VALVE BUILT INTO THE FLOW DIVIDER/COMBINER VALVES. THE CROSS OVER RELIEF ALLOWS THE CYLINDERS TO RE-SYNCHRONIZE AT THE END OF STROKE. IN ORDER FOR THIS VALVE TO FUNCTION PROPERLY, ALL AIR MUST BE REMOVED FROM THE DIVIDER/COMBINER CIRCUIT USING THE METHOD DESCRIBED ABOVE.

- K. We are now ready to bleed the air out of the Gantry UP-DOWN cylinder. First raise the arms high enough that the roller assembly is approximately four feet higher than the roll rest. Operate the "UP-DOWN" valve in the DOWN (cylinder retract) position first to fill the top side of the cylinder with oil. Hold the control valve in the down position until you hear the hydraulic relief valve open for 5 seconds. Operate the valve so the cylinder moves upward to the end of its stroke and hold in the raise position until the valve has gone over relief for 5 seconds. Run the gantry up and down a few times and hold the lever open for a few seconds at the end of each stroke to force any air in the cylinder or lines back to tank. If the hoses are reversed, that is, if the gantry goes up when the handle is moved to the DOWN position, exchange the hoses at the valve. Re-bleed if necessary.

RP4500SARG SYSTEM INSTALLATION

- L. Bleed the TELESCOPIC ARM CYLINDERS in the same manner as the arm cylinders. Begin with retracting the arms fully and then extend them fully. Be sure to hold the valve handle at both ends of the cylinder stroke for a few seconds to force the cross over relief to open and re synchronize the cylinders. If the ARM EXTENSIONS do not move in and out, you may have to adjust the Relief Valve as shown above in Section L. Check to make sure the arms move "OUT" when the valve handle is moved in that direction. Correct as necessary.

NOTE: IN ORDER FOR THE SYSTEM TO OPERATE PROPERLY, ALL AIR MUST BE BLED FROM THE LINES AND CYLINDERS.

- M. Adjust the Flow Control Valves to control the speed of the arms in both directions so it takes 15-20 seconds to cover and uncover. These Flow Controls meter the flow in the reverse direction which means that when you are COVERING, the FLOW CONTROL attached to the "TEE" is controlling the speed and when you are UNCOVERING, the FLOW CONTROL attached to the FLOW DIVIDER/COMBINER is controlling the speed. Adjust these flow controls by turning the adjusting knob in a clockwise direction until the desired "COVER and UNCOVER" time is achieved. Lock the adjusting screw in place by tightening the screw on the side of the knob. **Once the flow controls have been set, they should not be adjusted again.**

5. FINAL CHECKS AND ADJUSTMENTS

- Grease the Arm Pivot Pins.
- Apply a spray lubricant to the teeth on the RACK and PINION gears.
- Lubricate the Telescopic Arm Extensions.
- Apply a spray lubricant to the stud that the Swivel Hose Clamps pivot on.
- Lubricate the Gantry Legs.
- Check all fasteners to make sure they are properly tightened.
- Check to see that all welding is complete and that gussets have been installed where needed.
- Make sure all fittings are tightened properly and there are no leaks in the hydraulic system.
- Make sure all hoses have been fastened properly to stationary objects and that chafe guard has been installed where needed.
- Make sure that the telescopic arm hoses move freely with the arms as they pivot from front to rear. They should be kept as short as possible so they will not catch on anything.

RP4500SARG SYSTEM INSTALLATION

OPERATING THE UNIT

GENERAL: There is a cross over relief valve built into the flow divider / combiners. This cross over relief allows the cylinders to re-synchronize at the end of stroke or when they come in contact with a stop. (i.e. Top Rear of Container or Roll Rest). In order for this valve to function properly and keep the arms and extensions moving together, the operator MUST: Extend the telescopic arms all the way out, hold the valve handle for a few seconds and then retract them all the way in, hold the valve handle for a few seconds and then extend out.

When covering, move the arms so the stabilizer bar rests on the top rear of the container. Hold the valve handle for a few seconds to re-synchronize the arms. When uncovering, move the arms to the front so the roller sits in the roll rest. Hold the valve handle for a few seconds to re-synchronize the arms.

FAILURE TO FOLLOW THIS PROCEDURE MAY RESULT IN ARMS NOT MOVING TOGETHER AND POSSIBLE DAMAGE TO THE SYSTEM.

TO COVER



1. Make sure that nobody is on or around the container.
2. Make sure the truck is clear of overhead wires.
3. Move the arms upward to clear the Roll Base/Rest and cab.
4. Adjust the telescopic arms in or out to clear the front corner of the container.
5. Raise the Gantry up until the Roll Base/Rest is even to or above the front of the container.
6. Move the arms to the rear of the container to cover the load, stopping approximately **1 foot** away from the rear of the container.
7. Adjust the telescopic end in or out so the **stabilizer bar** aligns with the top rear of the container.
8. Move the arms all the way down so the stabilizer bar sits on top of the container.
9. Lower the Gantry, so the Roll Base/Rest is 12-14" below the top front of the container.

TO UNCOVER



1. Make sure that nobody is on or around the container.
2. Make sure the truck is clear of overhead wires.
3. Raise the gantry up until the Roll Base/Rest is even with or above the front of the container.
4. Move the arms to the front of the truck, stopping 2-3 feet from the top front of the container.
5. Adjust the telescopic arms in or out to clear the top front corner of the container.
6. Lower the Gantry all the way down.
7. Lower the arms to approximately 1-2 feet from the Roll Base/Rest or cab.
8. Adjust the telescopic end in or out so the roller aligns with the Roll Base/Rest.
9. Lower the arms all the way down so the roller sits in the Roll Base/Rest.

HYDRAULIC FITTING CHART

Note: -4 Hose Fitting and Swivel are Separate Items

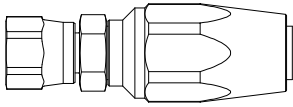

HR4685
Reusable Fitting for -4 Hose
w/ -6 JIC Female Swivel

Note: -8 Hose Fitting and Swivel are Separate Items

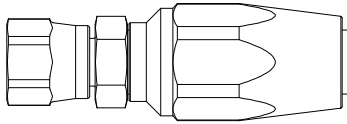

HR4721
Reusable Fitting for -8 Hose
w/ -8 JIC Female Swivel

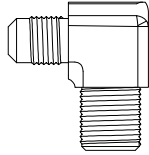

H7048
3/8 NPT M x -6 JIC M 90 DEG. ELL

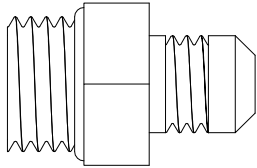

HR1505
-8 SAE M x -6 JIC M Adapter

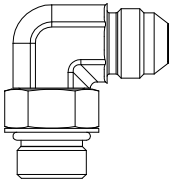

HR2021
-8 SAE M x -8 JIC M ELL

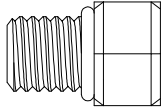

HR2057
-4 SAE Male Plug

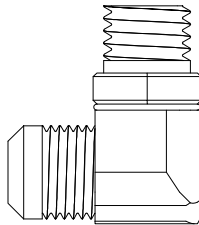

HR4681
-6 SAE M x -6 JIC M 90 Deg. ELL

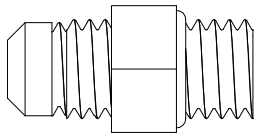

HR4682
-6 SAE M x -6 JIC M Straight
Adapter

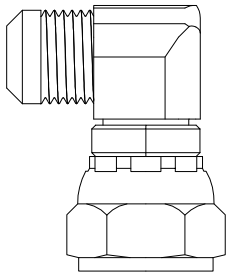

HR4683
-6 JIC M x -6 JIC F 90 Deg. ELL

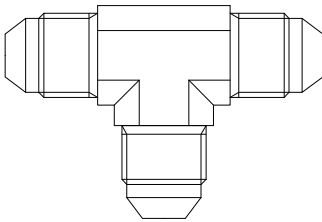

HR4684
-6 JIC M x -6 JIC M x -6 JIC M TEE

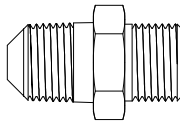

HR4716
1/4 NPT M x 6-JIC M Adapter

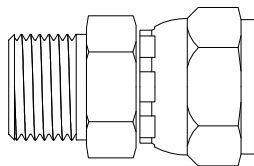

HR4717
1/4 NPT M x -6 JIC F Adapter

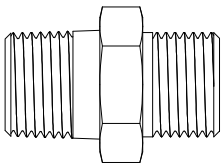

HR4722
1/2in. NPT M x -8 JIC M Adapter

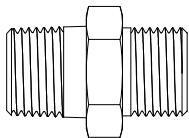

HR4729
-6 SAE M x -8 JIC M ADAPTER

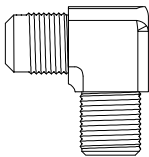

HR4553
1/4 NPT x -6 JIC 90 Deg. ELL

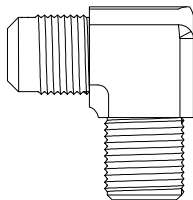

HR4693
1/2 NPT MALE x -8 JIC 90 Deg ELL

NOTES

NOTES

NOTES

RP4500SARG SYSTEM INSTALLATION

SPECIAL NOTE

NOT MANUFACTURED OR INTENDED FOR USE WITH HAZARDOUS WASTE

Pioneer, A Wastequip Co. will not be held responsible for damages to or caused by this automatic container covering system when it has not been used or installed in the manner prescribed in this manual. Any modifications to the system or deviations from the procedure outlined in this manual must be authorized in writing by Pioneer, A Wastequip Co.

WARRANTY

Pioneer, A Wastequip Co warrants its RP4500SARG covering system for a period of five (5) years against proven defective parts and workmanship. Excluded from this warranty is the fabric tarp. This warranty does not include damage to the unit caused by improper use, improper installation or lack of maintenance. Our liability is limited to the replacement of proven defective parts and does not include freight, labor or lost time due to or in connection with the failure of the parts. Any part will be replaced under the conditions of this warranty when Pioneer, A Wastequip Co has authorized a return and has received satisfactory evidence that the part(s) is(are) defective.