



January 30, 2025

To: Whom it may concern,
From: Building Drops, Inc.
On behalf of: Glass Warehouse LLC / Future Glass
1319 Rocky Point Drive, Suite 200
Oceanside, CA 92056
Report: PER 9164
Subject: RAN-CHRES Base Shoe System



Scope:

The purpose of this report is to evaluate the performance of the RAN-CHRES Base Shoe System manufactured by Glass Warehouse LLC / Future Glass. The conditions in this report meet all the applicable requirements of the current International Building Code. Glass thicknesses and properties were extracted from ASTM E1300. Steel members and connections were designed according to AISC Design Guides. ICC Acceptance Criteria AC439 and ASTM E2358 were used for determining applicable design criteria for railing systems. A summary of standards can be found on the following pages.

Only rectangular glass is covered within this report, different glass shapes do not apply to this analysis. Gaskets may be modified according to different glass thicknesses as long as thickness is specified in this analysis.

The glass balustrade system uses a stainless steel base shoe to support the glass lights specified herein. The glass base shoe system has been designed for the following loading conditions:

- 200 lb concentrated load at the top of glass or at the top rail
- 50 lbs linear load applied at the top of glass or at the top rail
- Allowable wind load as shown on the tables within this report

This report provides glass thicknesses the base shoe has been designed to support. Other glass thicknesses may be used but are outside of the scope of this report.

Instructions for Use

1. Determine jobsite wind load using table 1.
2. Select desired glass composition from tables 3, 4, 5, 6, 7, 8, 9, 10, 11, and 12.
3. Determine max. glass size based on wind load requirements using table 1 for reference.
4. Using table 15, choose desired anchor type and verify allowable wind load is greater than the glass allowable wind load.

RAN-CHRES Base Shoe System

Project Description: Glass Warehouse LLC / Future Glass RAN-CHRES Base Shoe Engineering Analysis	Date: January 30, 2025	Customer: Glass Warehouse LLC / Future Glass	
		Project #: EEV-24-0207	
	Engineer: SH	PER: 9164	Page #: Page 1 of 28

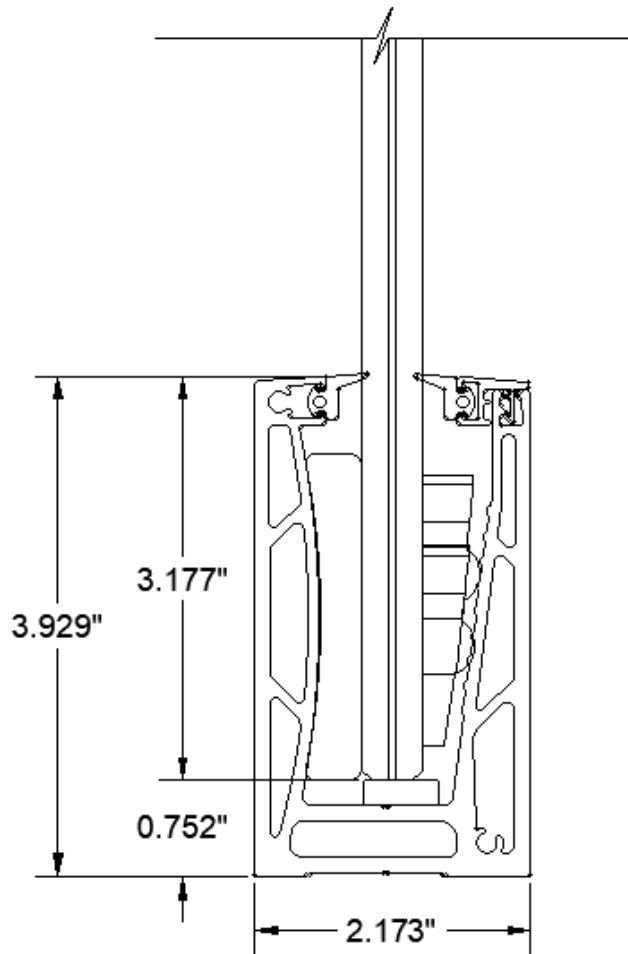

Standards/Referenced Publications

ASTM E1300	IBC 1607.8.1	ICC AC439
ASTM E2358	AISC Design Guides	ASTM C1048-97b
CPSC 16 CFR 1201	ANSI Z97.1	AAMA CW-12-84, Structural Properties for glass
AISC Design Guide 27	IBC 2407.1.1	NDS 2018
ASTM E6.2.1.1	SEI/ASCE 8-02	

Limits of Use:

Project Description: Glass Warehouse LLC / Future Glass RAN-CHRES Base Shoe Engineering Analysis	Date: January 30, 2025	Customer: Glass Warehouse LLC / Future Glass	
	Engineer: SH	Project #: EEV-24-0207	
		PER: 9164	Page #: Page 2 of 28



YOU ENVISION IT – WE ENGINEER IT

1900 NE Miami Ct., Ste. 2-15
Miami, FL 33132
TEL: 954.399-8478 | FAX: 954.744.4738
WEB: www.buildingdrops.com

1. This product has been evaluated and is in compliance with the 2015, 2018, and 2021 editions of the International Building Code.
2. Product installation shall be as listed herein. Site conditions that deviate from those specified shall require further engineering analysis by a licensed engineer or registered architect.
3. When used in areas requiring wind borne debris protection this product complies with chapter 16 of the 2015, 2018, and 2021 editions of the International Building Code and does require an impact resistant covering in areas requiring impact resistance.

Conclusion:

In my professional opinion, the RAN-CHRES Base Shoe System manufactured by Glass Warehouse LLC / Future Glass is adequate for use under the limitations provided within this report.

I trust that this will satisfy your needs, however, feel free to call if you have any questions.

***Certification of Independence:** Please note that I do not have nor will I acquire a financial interest in any company manufacturing or distributing the product(s) for which this report is being issued. Also, I do not have nor will I acquire a financial interest in any other entity involved in the approval process of the listed product(s).*



Project Description: Glass Warehouse LLC / Future Glass RAN-CHRES Base Shoe Engineering Analysis	Date: January 30, 2025	Customer: Glass Warehouse LLC / Future Glass	
		Project #: EEV-24-0207	
	Engineer: SH	PER: 9164	Page #: Page 3 of 28

Analysis and Findings

Under the appropriate load conditions for the system, the main load cases are summarized below:

Loading:

Horizontal Load to Base Shoe: $25 \text{ psf} * H$ or $W_L * H$

Balustrade Moments: $M_i = 25 \text{ psf} * H^2/2$ or $W_L * H^2/2$

For Top Rails:
 $M_C = 200 \text{ lbs} * H$
 $M_U = 50 \text{ plf} * H$

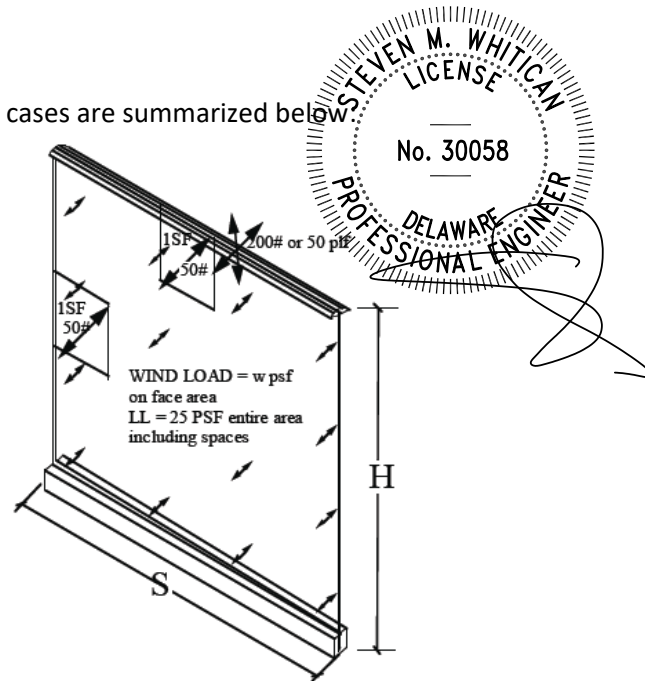

Wind Loads on Fences or Guards

The wind load table below has been calculated in accordance with ASCE 7-22 section 29.4, Design Wind Loads on Solid Freestanding Wall and Solid Signs. This section is applicable for free standing building guard rails, wind walls, and balcony railings that return to building walls.

Table 1: Wind Loads on Fences or Guards

Wind Loads (PSF)						
Wind Speed (mph)	W _{ASD} for C _f = 1.3			W _{ASD} for C _f = 2.6		
	Exp. B K _z = 0.7	Exp. C K _z = 0.85	Exp. D K _z = 1.03	Exp. B K _z = 0.7	Exp. C K _z = 0.85	Exp. D K _z = 1.03
100	9.50	11.53	13.98	19.00	23.07	27.95
110	11.49	13.95	16.91	22.98	27.91	33.82
120	13.68	16.61	20.12	27.35	33.21	40.25
130	16.05	19.49	23.62	32.10	38.98	47.24
140	18.62	22.60	27.39	37.23	45.21	54.78
150	21.37	25.95	31.44	42.74	51.90	62.89
160	24.31	29.52	35.78	48.63	59.05	71.55
170	27.45	33.33	40.39	54.90	66.66	80.78
180	30.77	37.37	45.28	61.54	74.73	90.56

Refer to the appendix of this report for detailed wind load calculations.

Project Description: Glass Warehouse LLC / Future Glass RAN-CHRES Base Shoe Engineering Analysis	Date: January 30, 2025	Customer: Glass Warehouse LLC / Future Glass	
	Engineer: SH	Project #: EEV-24-0207	
		PER: 9164	Page #: Page 4 of 28

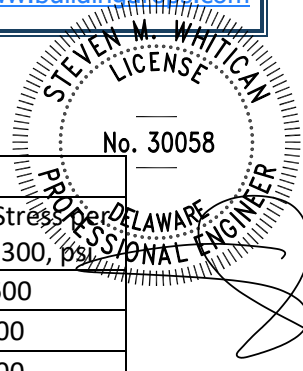

Glass Strength

Table 2: Glass properties extracted from ASTM E1300

Glass properties				
Glass types	Modulus of rupture, psi	All. Bending Stress, psi	All. Compressive Stress, psi	All. Glass Stress per ASTM E1300, psi
Tempered	24000	6000	6000	10600
Heat Strengthened	12000	3000	3000	5300
Annealed	6000	1500	1500	2900

Allowable Wind Load Table for Monolithic Glass

Table 3: 1/2" Monolithic Tempered Glass

Allowable Wind Pressure (PSF)						
Glass Width (in.)	Glass Height (in.)					
	36	39.75	42	48	60	72
12	59.67	48.52	42.92	31.76	19.77	11.15
24	48.25	39.14	34.71	25.78	16.09	9.05
36	39.64	32.38	28.70	21.36	13.36	7.61
42	*	*	25.24	18.85	11.80	6.72
48	*	*	*	16.56	10.41	5.88
60	*	*	*	*	8.51	4.86
72	*	*	*	*	*	4.09

*Note: Allowable wind load is the same as last value in the column.

Allowable Wind Load Tables for Laminated Glass

Table 4: 7/16" O.A. Laminated Glass: 3/16" Tempered Glass – 0.060" PVB – 3/16" Tempered Glass

Allowable Wind Pressure (PSF)									
Glass Width (in.)	Effective Thickness		Allowable Moment (lb-in/ft)	Glass Height (in.)					
	Deflection	Stress		36	39.75	42	48	60	72
12	0.234	0.264	1472	24.78	20.33	18.21	13.94	8.92	6.20
24	0.252	0.285	1724	29.02	23.80	21.32	16.32	10.45	7.25
36	0.274	0.310	2038	34.31	28.14	25.20	19.30	12.35	8.58
42	0.285	0.322	2194	*	*	27.14	20.78	13.30	9.23
48	0.296	0.332	2342	*	*	*	22.18	14.19	9.86
60	0.316	0.350	2602	*	*	*	*	15.77	10.95
72	0.332	0.364	2813	*	*	*	*	*	11.84

*Note: Allowable wind load is the same as last value in the column.

Project Description: Glass Warehouse LLC / Future Glass RAN-CHRES Base Shoe Engineering Analysis	Date: January 30, 2025	Customer: Glass Warehouse LLC / Future Glass	
	Engineer: SH	Project #: EEV-24-0207	
	PER: 9164	Page #: Page 5 of 28	



Table 5: 7/16" O.A. Laminated Glass: 3/16" Tempered Glass – 0.060" PVB Stiff – 3/16" Tempered Glass

Glass Width (in.)	Effective Thickness		Allowable Moment (lb-in/ft)	Glass Height (in.)					
	Deflection	Stress		36	39.75	42	48	60	72
12	0.249	0.282	1687	28.41	23.30	20.87	15.98	10.23	7.10
24	0.291	0.327	2270	38.22	31.35	28.08	21.50	13.76	9.55
36	0.327	0.360	2740	46.14	37.84	33.90	25.95	16.61	11.53
42	0.340	0.371	2912	*	*	36.01	27.57	17.65	12.25
48	0.352	0.379	3048	*	*	*	28.86	18.47	12.83
60	0.369	0.391	3242	*	*	*	*	19.65	13.65
72	0.381	0.399	3368	*	*	*	*	*	14.18

*Note: Allowable wind load is the same as last value in the column.

Table 6: 7/16" O.A. Laminated Glass: 3/16" Tempered Glass – 0.060" SentryGlas – 3/16" Tempered Glass

Glass Width (in.)	Effective Thickness		Allowable Moment (lb-in/ft)	Glass Height (in.)					
	Deflection	Stress		36	39.75	42	48	60	72
12	0.313	0.348	2564	43.16	35.40	31.71	24.28	15.54	10.79
24	0.371	0.392	3266	54.98	45.09	40.39	30.93	19.79	13.74
36	0.394	0.406	3498	58.88	48.30	43.26	33.12	21.20	14.72
42	0.400	0.409	3554	*	*	43.96	33.66	21.54	14.96
48	0.404	0.412	3593	*	*	*	34.02	21.78	15.12
60	0.409	0.414	3640	*	*	*	*	22.06	15.32
72	0.412	0.416	3666	*	*	*	*	*	15.43

*Note: Allowable wind load is the same as last value in the column.



Project Description: Glass Warehouse LLC / Future Glass RAN-CHRES Base Shoe Engineering Analysis	Date: January 30, 2025	Customer: Glass Warehouse LLC / Future Glass	
	Engineer: SH	Project #: EEV-24-0207	
	PER: 9164	Page #: Page 6 of 28	

Table 7: 9/16" O.A. Laminated Glass: 1/4" Tempered Glass – 0.090" PVB – 1/4" Tempered Glass

Glass Width (in.)	Effective Thickness		Allowable Moment (lb-in/ft)	Glass Height (in.)					
	Deflection	Stress		36	39.75	42	48	60	72
12	0.283	0.318	2142	36.06	29.58	26.49	20.29	12.98	9.02
24	0.300	0.338	2428	40.87	33.52	30.03	22.99	14.71	10.22
36	0.322	0.364	2803	47.18	38.70	34.67	26.54	16.99	11.80
42	0.334	0.376	2997	*	*	37.07	28.38	18.17	12.61
48	0.345	0.388	3186	*	*	*	30.17	19.31	13.41
60	0.367	0.408	3533	*	*	*	*	21.41	14.87
72	0.386	0.425	3825	*	*	*	*	*	16.10

*Note: Allowable wind load is the same as last value in the column.

Table 8: 9/16" O.A. Laminated Glass: 1/4" Tempered Glass – 0.090" PVB Stiff – 1/4" Tempered Glass

Glass Width (in.)	Effective Thickness		Allowable Moment (lb-in/ft)	Glass Height (in.)					
	Deflection	Stress		36	39.75	42	48	60	72
12	0.297	0.335	2386	40.17	32.95	29.51	22.59	14.46	10.04
24	0.340	0.382	3094	52.09	42.73	38.27	29.30	18.75	13.02
36	0.379	0.419	3723	62.68	51.41	46.05	35.26	22.56	15.67
42	0.395	0.433	3966	*	*	49.06	37.56	24.04	16.69
48	0.409	0.443	4166	*	*	*	39.45	25.25	17.53
60	0.431	0.459	4460	*	*	*	*	27.03	18.77
72	0.446	0.469	4657	*	*	*	*	*	19.60

*Note: Allowable wind load is the same as last value in the column.



Project Description: Glass Warehouse LLC / Future Glass RAN-CHRES Base Shoe Engineering Analysis	Date: January 30, 2025	Customer: Glass Warehouse LLC / Future Glass	
	Engineer: SH	Project #: EEV-24-0207	
	PER: 9164	Page #: Page 7 of 28	



Table 9: 9/16" O.A. Laminated Glass: 1/4" Tempered Glass – 0.090" SentryGlas – 1/4" Tempered Glass

Glass Width (in.)	Effective Thickness		Allowable Moment (lb-in/ft)	Glass Height (in.)					
	Deflection	Stress		36	39.75	42	48	60	72
12	0.364	0.405	3480	58.59	48.06	43.05	32.96	21.09	14.65
24	0.433	0.461	4496	75.69	62.08	55.61	42.58	27.25	18.92
36	0.463	0.479	4864	81.89	67.17	60.16	46.06	29.48	20.47
42	0.471	0.484	4957	*	*	61.31	46.94	30.04	20.86
48	0.476	0.487	5020	*	*	*	47.54	30.43	21.13
60	0.484	0.490	5099	*	*	*	*	30.90	21.46
72	0.488	0.493	5143	*	*	*	*	*	21.65

*Note: Allowable wind load is the same as last value in the column.

Table 10: 11/16" O.A. Laminated Glass: 5/16" Tempered Glass – 0.090" PVB – 5/16" Tempered Glass

Glass Width (in.)	Effective Thickness		Allowable Moment (lb-in/ft)	Glass Height (in.)					
	Deflection	Stress		36	39.75	42	48	60	72
12	0.374	0.420	3743	63.02	51.69	46.30	35.45	22.69	15.75
24	0.390	0.439	4092	68.89	56.51	50.62	38.75	24.80	17.22
36	0.413	0.465	4578	77.07	63.21	56.62	43.35	27.74	19.27
42	0.425	0.478	4843	*	*	59.90	45.86	29.35	20.38
48	0.437	0.491	5110	*	*	*	48.39	30.97	21.51
60	0.462	0.515	5624	*	*	*	*	34.09	23.67
72	0.484	0.536	6086	*	*	*	*	*	25.61

*Note: Allowable wind load is the same as last value in the column.



Project Description: Glass Warehouse LLC / Future Glass RAN-CHRES Base Shoe Engineering Analysis	Date: January 30, 2025	Customer: Glass Warehouse LLC / Future Glass	
	Engineer: SH	Project #: EEV-24-0207	
	PER: 9164	Page #: Page 8 of 28	

Table 11: 11/16" O.A. Laminated Glass: 5/16" Tempered Glass – 0.090" PVB ES – 5/16" Tempered Glass

Glass Width (in.)	Effective Thickness		Allowable Moment (lb-in/ft)	Glass Height (in.)					
	Deflection	Stress		36	39.75	42	48	60	72
12	0.388	0.437	4040	68.01	55.79	49.97	38.26	24.49	17.00
24	0.431	0.485	4979	83.81	68.75	61.58	47.14	30.17	20.95
36	0.476	0.529	5922	99.70	81.78	73.25	56.08	35.89	24.93
42	0.496	0.546	6320	*	*	78.16	59.84	38.30	26.60
48	0.513	0.560	6660	*	*	*	63.07	40.36	28.03
60	0.542	0.582	7189	*	*	*	*	43.57	30.26
72	0.563	0.597	7561	*	*	*	*	*	31.82

*Note: Allowable wind load is the same as last value in the column.

Table 12: 11/16" O.A. Laminated Glass: 5/16" Tempered Glass – 0.090" SentryGlas – 5/16" Tempered Glass

Glass Width (in.)	Effective Thickness		Allowable Moment (lb-in/ft)	Glass Height (in.)					
	Deflection	Stress		36	39.75	42	48	60	72
12	0.458	0.511	5544	93.34	76.56	68.57	52.50	33.60	23.33
24	0.546	0.585	7256	122.15	100.19	89.75	68.71	43.98	30.54
36	0.588	0.613	7972	134.21	110.08	98.60	75.49	48.31	33.55
42	0.600	0.620	8162	*	*	100.95	77.29	49.46	34.35
48	0.609	0.625	8294	*	*	*	78.54	50.27	34.91
60	0.620	0.632	8460	*	*	*	*	51.27	35.60
72	0.627	0.635	8555	*	*	*	*	*	36.00

*Note: Allowable wind load is the same as last value in the column.

Refer to the appendix of this report for detailed glass capacity calculations.

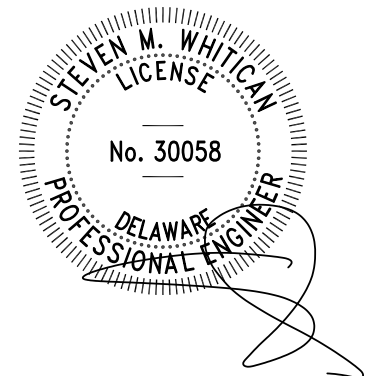

Project Description: Glass Warehouse LLC / Future Glass RAN-CHRES Base Shoe Engineering Analysis	Date: January 30, 2025	Customer: Glass Warehouse LLC / Future Glass	
	Engineer: SH	Project #: EEV-24-0207	
	PER: 9164	Page #: Page 9 of 28	



Glass Height based on 1" Deflection Limitation

Table 13: 7/16" O.A. Laminated Glass

Light Width (in)	Max. Glass Height (in.)					
	50plf PVB	50plf PVB ES	50plf SGP	200lb PVB	200lb PVB ES	200lb SGP
12	22.52	24.11	29.72	12.09	12.87	15.58
24	24.37	27.96	33.54	17.00	19.41	23.08
36	26.49	30.72	34.71	21.36	24.67	27.77
42	27.49	31.67	34.99	23.39	26.86	29.60
48	28.40	32.40	35.18	25.32	28.81	31.22
60	29.94	33.42	35.41	28.84	32.13	34.01
72	31.13	34.06	35.54	31.93	34.90	36.38

Table 14: 9/16" O.A. Laminated Glass

Light Width (in)	Max. Glass Height (in.)					
	50plf PVB	50plf PVB ES	50plf SGP	200lb PVB	200lb PVB ES	200lb SGP
12	27.16	28.67	34.62	14.36	15.08	17.84
24	28.92	32.65	39.35	20.04	22.50	26.85
36	31.07	35.81	40.93	24.94	28.62	32.55
42	32.13	36.96	41.32	27.24	31.22	34.77
48	33.13	37.88	41.58	29.44	33.55	36.73
60	34.88	39.19	41.91	33.51	37.56	40.10
72	36.30	40.05	42.09	37.15	40.92	42.96



Project Description: Glass Warehouse LLC / Future Glass RAN-CHRES Base Shoe Engineering Analysis	Date: January 30, 2025	Customer: Glass Warehouse LLC / Future Glass	
	Engineer: SH	Project #: EEV-24-0207	
	PER: 9164	Page #: Page 10 of 28	



RAN-CHRES Base Shoe Installation

Anchor Schedule

Anchor Schedule					
Substrate	Anchor Type	Min. Embedment (in.)	Min. Edge Distance (in.)	On Center Spacing (in.)	Allowable Moment (in-lb)
Wood SG = 0.55 min.	1/2" ASTM F593 Bolt	3.00	0.75	9.84	5810.03
	3/8" Lag Screw	3.00	0.75	9.84	1295.53
	1/2" Lag Screw	3.00	0.75	9.84	1609.13
Concrete 4000 PSI min.	3/8" Dewalt Screw-Bolt+	4.50	2.50	9.84	2658.31
	1/2" Dewalt Screw-Bolt+	4.50	2.50	9.84	3307.69
	3/8" ITW RedHead Dynabolt	1.50	2.50	9.84	841.78
	1/2" ITW RedHead Dynabolt	1.875	2.50	9.84	1194.59
	3/8" Hilti HIT-Z Rod with HIT-HY 200 Adhesive	4.50	2.375	9.84	1403.51
	1/2" Hilti HIT-Z Rod with HIT-HY 200 Adhesive	4.50	2.625	9.84	1810.37
Steel 1/4" Thk. Min.	3/8" HWH Self-Tapping Screw	Min. 3 threads penetration past steel structure	0.50	9.84	1672.71
	1/2" HWH Self-Tapping Screw	Min. 3 threads penetration past steel structure	0.50	9.84	2229.55

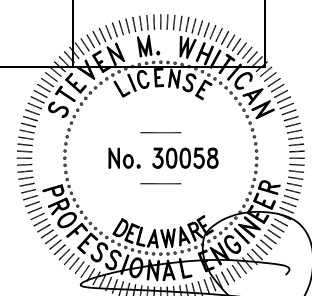

Project Description: Glass Warehouse LLC / Future Glass RAN-CHRES Base Shoe Engineering Analysis	Date: January 30, 2025	Customer: Glass Warehouse LLC / Future Glass	
	Engineer: SH	Project #: EEV-24-0207	
		PER: 9164	Page #: Page 11 of 28



Table 15: Installation Design Pressure Table

Anchors Allowable Wind Load Capacity (PSF)							
Substrate	Anchor Type	Guard Height (in.)					
		36	39.75	42	48	60	72
Wood SG = 0.55 min.	1/2" ASTM F593 Bolt	97.81	80.23	71.86	55.02	35.21	24.45
	3/8" Lag Screw	21.81	17.89	16.02	12.27	7.85	5.45
	1/2" Lag Screw	27.09	22.22	19.90	15.24	9.75	6.77
Concrete 4000 PSI min.	3/8" Dewalt Screw-Bolt+	44.75	36.71	32.88	25.17	16.11	11.19
	1/2" Dewalt Screw-Bolt+	55.69	45.67	40.91	31.32	20.05	13.92
	3/8" ITW RedHead Dynabolt	14.17	11.62	10.41	7.97	5.10	3.54
	1/2" ITW RedHead Dynabolt	20.11	16.50	14.78	11.31	7.24	5.03
	3/8" Hilti HIT-Z Rod with HIT-HY 200 Adhesive	23.63	19.38	17.36	13.29	8.51	5.91
	1/2" Hilti HIT-Z Rod with HIT-HY 200 Adhesive	30.48	25.00	22.39	17.14	10.97	7.62
Steel 1/4" Thk. Min.	3/8" HWH Self-Tapping Screw	28.16	23.10	20.69	15.84	10.14	7.04
	1/2" HWH Self-Tapping Screw	37.53	30.79	27.58	21.11	13.51	9.38

*Note: Common wood species with SG ≥ 0.42 include the following: Spruce Pine Fir, Southern Pine, Mixed Maple, Douglas Fir Larch.



Project Description: Glass Warehouse LLC / Future Glass RAN-CHRES Base Shoe Engineering Analysis	Date: January 30, 2025	Customer: Glass Warehouse LLC / Future Glass	
	Engineer: SH	Project #: EEV-24-0207	
	PER: 9164	Page #: Page 12 of 28	

Handrail Allowable Span Calculations

Guard applications require a top rail or handrail. The rail shall have adequate strength to support the live load of 200 lb concentrated or 50 plf distributed load assuming the failure of one glass light at the location of the loading. No US building codes or adopted standards define the limit state of the guard hand rail for this condition. IBC 2407.1.2 states “shall be otherwise supported to remain in place should one baluster fail.” There is no additional explanation in the IBC as to how this is to be determined. ICC Acceptance Criteria 439 was adopted to provide a methodology for determining if a glass balustrade guard meets the requirements of IBC 2407. ICC AC 439 requires the rail to be capable of supporting a 334# load (SF = 1.67 for 200# load) with no more than 12” deflection, yielding or other damage is permitted since the loss of a glass light will necessitate guard repairs. For light failure only the horizontal load case applies for laminated glass.

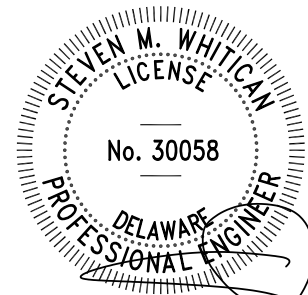
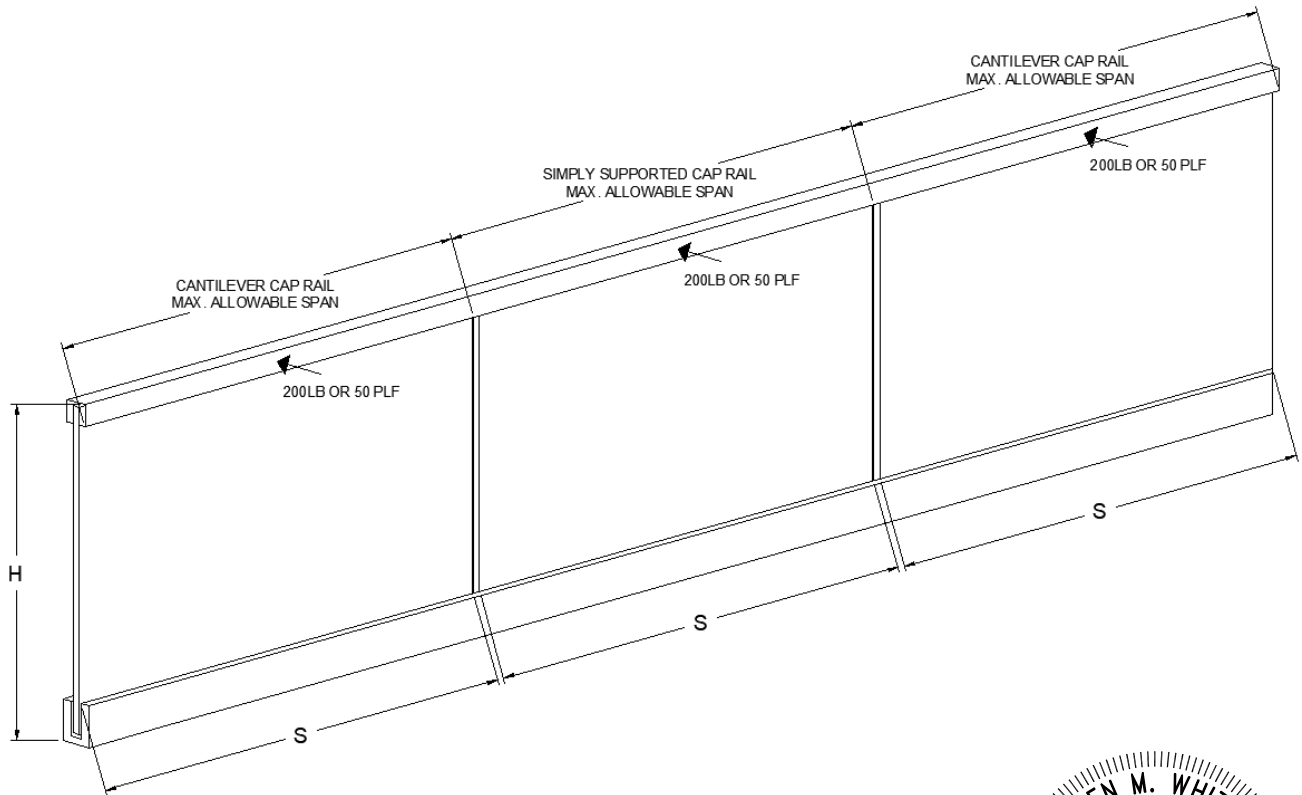

Project Description: Glass Warehouse LLC / Future Glass RAN-CHRES Base Shoe Engineering Analysis	Date: January 30, 2025	Customer: Glass Warehouse LLC / Future Glass	
	Engineer: SH	Project #: EEV-24-0207	
	PER: 9164	Page #: Page 13 of 28	

COR-AHS Handrail Allowable Span

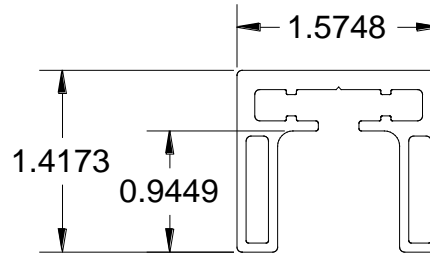

Cap Rail = AH4036
 Area = 0.7269 in²
 Perim. = 14.3614 in
 Ixx = 0.1389 in⁴
 Iyy = 0.2377 in⁴
 rxx = 0.4371 in
 ryy = 0.5719 in
 Cxx = 0.7875 in
 Cyy = 0.8968 in
 Sxx = 0.1549 in³
 Syy = 0.3018 in³
 t = 0.071 in
 w = 0.9449 in

Material = 2205 Stainless Steel
 Fy = 65 ksi
 Fu = 90 ksi

$$F_{cr} = \frac{\pi^2 k \eta E_o}{12(1-\mu^2)(w/t)^2}$$

η (Plasticity Reduction Factor) = 0.5 (Table A6a)
 K (plate buckling coef.) = 3.51 (Section 2)
 E_o = 27000 ksi
 μ (Poisson's Ratio) = 0.3 (Elastic Range)

$$\eta = \sqrt{\frac{E_t}{E_o}}$$

F_{cr} = 241.67 ksi

Project Description: Glass Warehouse LLC / Future Glass RAN-CHRES Base Shoe Engineering Analysis	Date: January 30, 2025	Customer: Glass Warehouse LLC / Future Glass	
	Engineer: SH	Project #: EEV-24-0207	
		PER: 9164	Page #: Page 14 of 28



$$M_n = 1.25S_eF_y$$

$$M_n \text{ Vertical Load} = 12.5843 \text{ k-in}$$

$$M_n \text{ Horizontal Load} = 24.5246 \text{ k-in}$$

$$M_{nult} = S_eF_{cr}$$

$$M_{ULT} \text{ Vertical Load} = 13.9396 \text{ k-in}$$

$$M_{ULT} \text{ Horizontal Load} = 27.1657 \text{ k-in}$$

Simply Supported Rail

$$M_w = wL^2/10$$

$$L_{\text{uniform Vert.}} = 137.39 \text{ in}$$

$$L_{\text{uniform Horiz.}} = 191.80 \text{ in}$$

$$M_c = PL/5$$

$$L_{\text{concentrated vert.}} = 188.39 \text{ in}$$

$$L_{\text{concentrated horiz.}} = 367.13 \text{ in}$$

Allowable Rail Span =	137	in =	11.42	ft
-----------------------	-----	------	-------	----

Cantilever Supported Rail

$$M_{wc} = wL^2/2$$

$$L_{\text{uniform Vert.}} = 61.44 \text{ in}$$

$$L_{\text{uniform Horiz.}} = 85.78 \text{ in}$$

$$M_{cc} = PL$$

$$L_{\text{concentrated vert.}} = 37.68 \text{ in}$$

$$L_{\text{concentrated horiz.}} = 73.43 \text{ in}$$

Allowable Rail Span =	37	in =	3.08	ft
-----------------------	----	------	------	----

Project Description: Glass Warehouse LLC / Future Glass RAN-CHRES Base Shoe Engineering Analysis	Date: January 30, 2025	Customer: Glass Warehouse LLC / Future Glass	
		Project #: EEV-24-0207	
	Engineer: SH	PER: 9164	Page #: Page 15 of 28

DRA-AHR42 Handrail Allowable Span

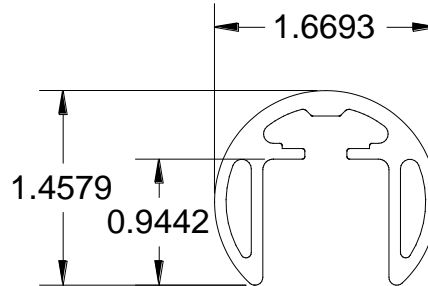

Cap Rail = AHR42
 Area = 0.6745 in²
 Perim. = 11.8379 in
 Ixx = 0.1130 in⁴
 Iyy = 0.1996 in⁴
 rxx = 0.4092 in
 ryy = 0.5439 in
 Cxx = 0.8347 in
 Cyy = 0.8254 in
 Sxx = 0.1369 in³
 Syy = 0.2391 in³
 t = 0.0866 in
 w = 0.9442 in
 Material = 2205 Stainless Steel
 Fy = 65 ksi
 Fu = 90 ksi

$$F_{cr} = \frac{\pi^2 k \eta E_0}{12(1-\mu^2)(w/t)^2}$$

η (Plasticity Reduction Factor) = 0.5 (Table A6a)
 K (plate buckling coef.) = 4 (Section 2)
 E₀ = 27000 ksi
 μ (Poisson's Ratio) = 0.3 (Elastic Range)

$$\eta = \sqrt{\frac{E_t}{E_0}}$$

F_{cr} = 410.56 ksi

Project Description: Glass Warehouse LLC / Future Glass RAN-CHRES Base Shoe Engineering Analysis	Date: January 30, 2025	Customer: Glass Warehouse LLC / Future Glass	
		Project #: EEV-24-0207	
	Engineer: SH	PER: 9164	Page #: Page 16 of 28



$$M_n = 1.25S_eF_y$$

$M_{n \text{ Vertical Load}} = 11.1234 \text{ k-in}$
 $M_{n \text{ Horizontal Load}} = 19.4291 \text{ k-in}$

$$M_{nult} = S_eF_{cr}$$

$M_{ULT \text{ Vertical Load}} = 12.3213 \text{ k-in}$
 $M_{ULT \text{ Horizontal Load}} = 21.5215 \text{ k-in}$

Simply Supported Rail

$$M_w = wL^2/10$$

$L_{\text{uniform Vert.}} = 129.17 \text{ in}$
 $L_{\text{uniform Horiz.}} = 170.72 \text{ in}$

$$M_c = PL/5$$

$L_{\text{concentrated vert.}} = 166.52 \text{ in}$
 $L_{\text{concentrated horiz.}} = 290.86 \text{ in}$

Allowable Rail Span = 129 in = 10.75 ft

Cantilever Supported Rail

$$M_{wc} = wL^2/2$$

$L_{\text{uniform Vert.}} = 57.77 \text{ in}$
 $L_{\text{uniform Horiz.}} = 76.35 \text{ in}$

$$M_{cc} = PL$$

$L_{\text{concentrated vert.}} = 33.30 \text{ in}$
 $L_{\text{concentrated horiz.}} = 58.17 \text{ in}$

Allowable Rail Span = 33 in = 2.75 ft

Project Description: Glass Warehouse LLC / Future Glass RAN-CHRES Base Shoe Engineering Analysis	Date: January 30, 2025	Customer: Glass Warehouse LLC / Future Glass	
		Project #: EEV-24-0207	
	Engineer: SH	PER: 9164	Page #: Page 17 of 28

AGE-SHR42 Handrail Allowable Span

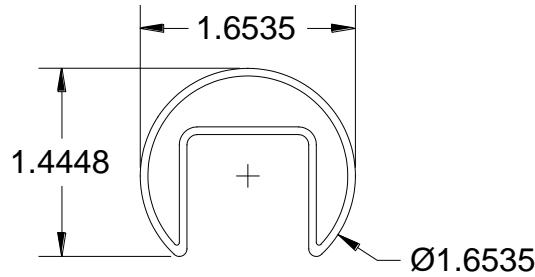

Cap Rail = HR42
 Area = 0.3905 in²
 Perim. = 13.2204 in
 Ixx = 0.0668 in⁴
 Iyy = 0.1178 in⁴
 rxx = 0.4135 in
 ryy = 0.5492 in
 Cxx = 0.8268 in
 Cyy = 0.7533 in
 Sxx = 0.0887 in³
 Syy = 0.1425 in³
 t = 0.059055 in
 w = 0.7224 in

Material = 2205 Stainless Steel

Fy = 65 ksi
 Fu = 90 ksi

$$F_{cr} = \frac{\pi^2 k \eta E_o}{12(1-\mu^2)(w/t)^2}$$

η (Plasticity Reduction Factor) = 0.62 (Table A6a)
 K (plate buckling coef.) = 4 (Section 2)
 E_o = 29000 ksi
 μ (Poisson's Ratio) = 0.3 (Elastic Range)

$$\eta = \sqrt{\frac{E_t}{E_o}}$$

F_{cr} = 434.40 ksi

Project Description: Glass Warehouse LLC / Future Glass RAN-CHRES Base Shoe Engineering Analysis	Date: January 30, 2025	Customer: Glass Warehouse LLC / Future Glass	
		Project #: EEV-24-0207	
	Engineer: SH	PER: 9164	Page #: Page 18 of 28

$$M_n = 1.25S_e F_y$$

M_n Vertical Load = 7.2050 k-in
 M_n Horizontal Load = 11.5763 k-in

$$M_{mult} = S_e F_{cr}$$

M_{ULT} Vertical Load = 38.5208 k-in
 M_{ULT} Horizontal Load = 61.8915 k-in



Simply Supported Rail

$$M_w = wL^2/10$$

$L_{uniform\ vert.}$ = 131.50 in
 $L_{uniform\ horiz.}$ = 166.68 in

$$M_c = PL/5$$

$L_{concentrated\ vert.}$ = 180.12 in
 $L_{concentrated\ horiz.}$ = 289.41 in

Allowable Rail Span = 131 in = 10.92 ft

Cantilever Supported Rail

$$M_{wc} = wL^2/2$$

$L_{uniform\ vert.}$ = 58.81 in
 $L_{uniform\ horiz.}$ = 74.54 in

$$M_{cc} = PL$$

$L_{concentrated\ vert.}$ = 36.02 in
 $L_{concentrated\ horiz.}$ = 57.88 in

Allowable Rail Span = 36 in = 3.00 ft

Project Description: Glass Warehouse LLC / Future Glass RAN-CHRES Base Shoe Engineering Analysis	Date: January 30, 2025	Customer: Glass Warehouse LLC / Future Glass	
	Engineer: SH	Project #: EEV-24-0207	
		PER: 9164	Page #: Page 19 of 28

MAT-SHS Handrail Allowable Span

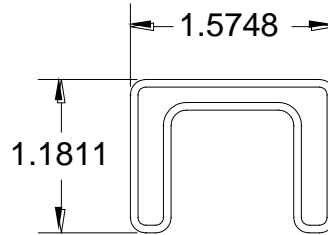

Cap Rail = MH4030S-XS

- Area = 0.4022 in²
- Perim. = 13.621 in
- I_{xx} = 0.0588 in⁴
- I_{yy} = 0.1302 in⁴
- r_{xx} = 0.3824 in
- r_{yy} = 0.569 in
- C_{xx} = 0.7874 in
- C_{yy} = 0.7041 in
- S_{xx} = 0.0835 in³
- S_{yy} = 0.1654 in³
- t = 0.0591 in
- w = 0.59055 in

Material = 2205 Stainless Steel

- F_y = 65 ksi
- F_u = 90 ksi

$$F_{cr} = \frac{\pi^2 k \eta E_0}{12(1-\mu^2)(w/t)^2}$$

- η (Plasticity Reduction Factor) = 0.62 (Table A6a)
- K (plate buckling coef.) = 4 (Section 2)
- E₀ = 29000 ksi
- μ (Poisson's Ratio) = 0.3 (Elastic Range)

$$\eta = \sqrt{\frac{E_t}{E_o}}$$

F_{cr} = 651.01 ksi

Project Description: Glass Warehouse LLC / Future Glass RAN-CHRES Base Shoe Engineering Analysis	Date: January 30, 2025	Customer: Glass Warehouse LLC / Future Glass	
		Project #: EEV-24-0207	
	Engineer: SH	PER: 9164	Page #: Page 20 of 28

$$M_n = 1.25S_eF_y$$

$$M_n \text{ Vertical Load} = 6.7853 \text{ k-in}$$

$$M_n \text{ Horizontal Load} = 13.4350 \text{ k-in}$$

$$M_{nult} = S_eF_{cr}$$

$$M_{ULT} \text{ Vertical Load} = 54.3665 \text{ k-in}$$

$$M_{ULT} \text{ Horizontal Load} = 107.6475 \text{ k-in}$$



Simply Supported Rail

$$M_w = wL^2/10$$

$$L_{\text{uniform Vert.}} = 127.61 \text{ in}$$

$$L_{\text{uniform Horiz.}} = 179.57 \text{ in}$$

$$M_c = PL/5$$

$$L_{\text{concentrated vert.}} = 169.63 \text{ in}$$

$$L_{\text{concentrated horiz.}} = 335.88 \text{ in}$$

Allowable Rail Span = 127 in = 10.58 ft

Cantilever Supported Rail

$$M_{wc} = wL^2/2$$

$$L_{\text{uniform Vert.}} = 57.07 \text{ in}$$

$$L_{\text{uniform Horiz.}} = 80.30 \text{ in}$$

$$M_{cc} = PL$$

$$L_{\text{concentrated vert.}} = 33.93 \text{ in}$$

$$L_{\text{concentrated horiz.}} = 67.18 \text{ in}$$

Allowable Rail Span = 33 in = 2.75 ft

Project Description: Glass Warehouse LLC / Future Glass RAN-CHRES Base Shoe Engineering Analysis	Date: January 30, 2025	Customer: Glass Warehouse LLC / Future Glass	
	Engineer: SH	Project #: EEV-24-0207	
	PER: 9164	Page #: Page 21 of 28	

HG25S XS Handrail Allowable Span

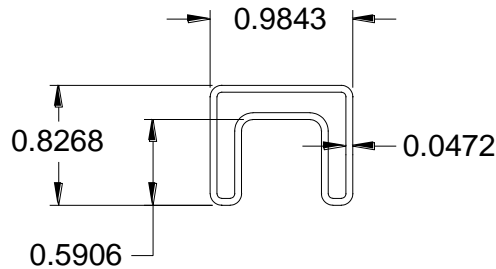

Cap Rail = HG25S

- Area = 0.2071 in²
- Perim. = 8.7687 in
- I_{xx} = 0.0143 in⁴
- I_{yy} = 0.0261 in⁴
- r_{xx} = 0.2629 in
- r_{yy} = 0.3548 in
- C_{xx} = 0.4921 in
- C_{yy} = 0.4685 in
- S_{xx} = 0.0305 in³
- S_{yy} = 0.0530 in³
- t = 0.0472 in
- w = 0.5906 in

Material = 2205 Stainless Steel

- F_y = 65 ksi
- F_u = 90 ksi

$$F_{cr} = \frac{\pi^2 k \eta E_o}{12(1-\mu^2)(w/t)^2}$$

- η (Plasticity Reduction Factor) = 0.5 (Table A6a)
- K (plate buckling coef.) = 4 (Section 2)
- E_o = 27000 ksi
- μ (Poisson's Ratio) = 0.3 (Elastic Range)

$$\eta = \sqrt{\frac{E_t}{E_o}}$$

F_{cr} = 311.72 ksi

Project Description: Glass Warehouse LLC / Future Glass RAN-CHRES Base Shoe Engineering Analysis	Date: January 30, 2025	Customer: Glass Warehouse LLC / Future Glass	
	Engineer: SH	Project #: EEV-24-0207	
		PER: 9164	Page #: Page 22 of 28

$$M_n = 1.25 S_e F_y$$

$$M_{n \text{ Vertical Load}} = 2.4800 \text{ k-in}$$

$$M_{n \text{ Horizontal Load}} = 4.3093 \text{ k-in}$$

$$M_{\text{mult}} = S_e F_{cr}$$

$$M_{\text{ULT Vertical Load}} = 2.7471 \text{ k-in}$$

$$M_{\text{ULT Horizontal Load}} = 4.7734 \text{ k-in}$$



Simply Supported Rail

$$M_w = wL^2/10$$

$$L_{\text{uniform Vert.}} = 60.99 \text{ in}$$

$$L_{\text{uniform Horiz.}} = 80.40 \text{ in}$$

$$M_c = PL/5$$

$$L_{\text{concentrated vert.}} = 37.13 \text{ in}$$

$$L_{\text{concentrated horiz.}} = 64.51 \text{ in}$$

Allowable Rail Span =	37	in =	3.08	ft
-----------------------	----	------	------	----

Cantilever Supported Rail

$$M_{wc} = wL^2/2$$

$$L_{\text{uniform Vert.}} = 27.28 \text{ in}$$

$$L_{\text{uniform Horiz.}} = 35.96 \text{ in}$$

$$M_{cc} = PL$$

$$L_{\text{concentrated vert.}} = 7.43 \text{ in}$$

$$L_{\text{concentrated horiz.}} = 12.90 \text{ in}$$

Allowable Rail Span =	7	in =	0.58	ft
-----------------------	---	------	------	----

Project Description: Glass Warehouse LLC / Future Glass RAN-CHRES Base Shoe Engineering Analysis	Date: January 30, 2025	Customer: Glass Warehouse LLC / Future Glass	
	Engineer: SH	Project #: EEV-24-0207	
	PER: 9164	Page #: Page 23 of 28	



YOU ENVISION IT – WE ENGINEER IT

1900 NE Miami Ct., Ste. 2-15
Miami, FL 33132
TEL: 954.399-8478 | FAX: 954.744.4738
WEB: www.buildingdrops.com



APPENDIX

Project Description: Glass Warehouse LLC / Future Glass RAN-CHRES Base Shoe Engineering Analysis	Date: January 30, 2025	Customer: Glass Warehouse LLC / Future Glass	
		Project #: EEV-24-0207	
	Engineer: SH	PER: 9164	Page #: Page 24 of 28

Wind Loads on Fences or Guards

$p = q_h(GC_p) = q_zGC_f$ (ASCE 7-10 eq. 7-16)
 $G = 0.85$ from (section 26.9.4.)
 $C_f = 2.5 * 0.8 * 0.6 = 1.2$ (Figure 29.4-1) with reduction for solid and end returns, will vary.
 $q_h = 0.00256K_zK_{zt}K_dV^2$ Where:
 K_z from (Table 29.3-1) at the height z of the railing centroid and exposure.
 $K_d = 0.85$ from (Table 26-6).
 K_{zt} From (Figure 26.8-1) for the site topography, typically 1.0.
 $V =$ Wind speed (mph) 3 second gust, (Figure 26.5-1A) or per local authority.
 Simplifying - Assuming $1.3 \leq C_f \leq 2.6$ (Typical limits for fence or guard with returns.)
 Adjustment for full height solid: $f = 1.8 - 1 = 0.8$
 Adjustment to Allowable Stress Design: $w_{asd} = 0.6w_{strength}$
 For $C_f = 1.3$: $F = q_h * 0.85 * 1.3 * 0.8 * 0.6 = 0.53 q_h$
 For $C_f = 2.6$: $F = q_h * 0.85 * 2.6 * 0.8 * 0.6 = 1.06 q_h$



Exposure	B	C	D
$K_z =$	0.70	0.85	1.03

Centroid of wind load acts at 0.55h on the fence.

$w_{asd} = 0.53 * 0.00256 * K_z * V^2$ or $w_{asd} = 1.06 * 0.00256 * K_z * V^2$

Wind Speed (mph)	Wind Loads (PSF)					
	W_{ASD} for $C_f = 1.3$			W_{ASD} for $C_f = 2.6$		
	Exp. B $K_z = 0.7$	Exp. C $K_z = 0.85$	Exp. D $K_z = 1.03$	Exp. B $K_z = 0.7$	Exp. C $K_z = 0.85$	Exp. D $K_z = 1.03$
100	9.50	11.53	13.98	19.00	23.07	27.95
110	11.49	13.95	16.91	22.98	27.91	33.82
120	13.68	16.61	20.12	27.35	33.21	40.25
130	16.05	19.49	23.62	32.10	38.98	47.24
140	18.62	22.60	27.39	37.23	45.21	54.78
150	21.37	25.95	31.44	42.74	51.90	62.89
160	24.31	29.52	35.78	48.63	59.05	71.55
170	27.45	33.33	40.39	54.90	66.66	80.78
180	30.77	37.37	45.28	61.54	74.73	90.56

Project Description: Glass Warehouse LLC / Future Glass RAN-CHRES Base Shoe Engineering Analysis	Date: January 30, 2025	Customer: Glass Warehouse LLC / Future Glass	
	Engineer: SH	Project #: EEV-24-0207	
		PER: 9164	Page #: Page 25 of 28

7/16" Laminated Glass Capacity

$$\begin{aligned}
 h_1 &= 0.180 \text{ in} \\
 h_2 &= 0.180 \text{ in} \\
 h_v &= 0.060 \text{ in} \\
 h_s &= 0.5(h_1+h_2)+h_v \\
 h_s &= 0.240 \text{ in} \\
 h_{s,1} &= h_{s,2} = (h_s h_1)/(h_1+h_2) \\
 h_{s,1} &= 0.120 \text{ in} \\
 h_{s,2} &= 0.120 \text{ in} \\
 I_s &= h_1 h^2_{s,2} + h_2 h^2_{s,1} \\
 I_s &= 0.0052
 \end{aligned}$$



Shortest Dimension (a) (in)	Γ PVB	Γ PVB ES	Γ SGP	$h_{ef,w}$ PVB	$h_{ef,w}$ PVB ES	$h_{ef,w}$ SGP	$h_{1,ef,\sigma}$ PVB	$h_{1,ef,\sigma}$ PVB ES	$h_{1,ef,\sigma}$ SGP
12	0.018	0.062	0.304	0.234	0.249	0.313	0.264	0.282	0.348
24	0.070	0.208	0.636	0.252	0.291	0.371	0.285	0.327	0.392
36	0.144	0.372	0.798	0.274	0.327	0.394	0.310	0.360	0.406
39.75	0.170	0.419	0.828	0.281	0.335	0.398	0.317	0.367	0.408
42	0.186	0.447	0.843	0.285	0.340	0.400	0.322	0.371	0.409
48	0.230	0.513	0.875	0.296	0.352	0.404	0.332	0.379	0.412
60	0.319	0.622	0.916	0.316	0.369	0.409	0.350	0.391	0.414
72	0.402	0.703	0.940	0.332	0.381	0.412	0.364	0.399	0.416

$$\begin{aligned}
 \Gamma &= 1/[1+9.6(EI_s h_v)/(Gh^2 a^2)] \\
 \text{effective thickness for deflection:} \\
 h_{ef,w} &= (h_1^3 + h_2^3 + 12\Gamma I_s)^{1/3} \\
 \text{effective thickness for glass stress:} \\
 h_{1,ef,\sigma} &= [h_{ef,w}^3/(h+2\Gamma h_{s,1})]^{1/2}
 \end{aligned}$$

Shortest Dimension (a) (in)	All. Wind Moment (lb-ft) PVB	All. Wind Moment (lb-ft) PVB ES	All. Wind Moment (lb-ft) SGP	All. LL Moment (lb-in/ft) PVB	All. LL Moment (lb-in/ft) PVB ES	All. LL Moment (lb-in/ft) SGP
12	123	141	214	833	965	1451
24	144	189	272	976	1285	1849
36	170	228	291	1153	1551	1980
39.75	178	238	295	1209	1614	2001
42	183	243	296	1242	1648	2012
48	195	254	299	1326	1725	2034
60	217	270	303	1473	1835	2060
72	234	281	306	1592	1907	2075

$$\begin{aligned}
 M_{GL} &= 6,000\text{psi} \cdot 2 \cdot h_{1,ef,\sigma}^2 = 12,000 h_{1,ef,\sigma}^2 \text{ } \#/\text{ft} = 1,000 h_{1,ef,\sigma}^2 \text{ } \#/\text{ft} \text{ For Live Loads} \\
 M_{LW} &= 9,600\text{psi} \cdot 2 \cdot h_{1,ef,\sigma}^2 \text{ For Wind Loads}
 \end{aligned}$$

Glass Panel Loads
 From IBC 1607.7.1

Light Width (in)	Max. Panel Height Live Loads (in.)					
	50 plf PVB	50 plf PVB ES	50 plf SGP	200 lb PVB	200 lb PVB ES	200 lb SGP
12	16.67	19.10	29.02	33.33	38.21	58.05
24	19.51	25.70	36.97	78.05	102.80	147.88
36	23.07	31.02	39.60	138.41	186.15	237.58
39.75	24.18	32.29	40.03	160.21	213.90	265.19
42	24.84	32.96	40.24	173.86	230.74	281.68
48	26.51	34.50	40.68	212.09	276.03	325.40
60	29.46	36.71	41.21	294.60	367.06	412.08
72	31.84	38.13	41.51	382.09	457.57	498.08

For 50 plf distributed load:
 $h = (M_d/u) = M_d/50\text{plf}$

For 200# load, not top rail:
 $h = M_d \cdot S/200\#$ where S = light length in feet when installed with cap rail
 For installation without a cap rail and load at corner of glass:
 $h = M_d \cdot (2/3 \cdot S)/200\#$ where S ≤ h

Project Description: Glass Warehouse LLC / Future Glass RAN-CHRES Base Shoe Engineering Analysis	Date: January 30, 2025	Customer: Glass Warehouse LLC / Future Glass	
	Engineer: SH	Project #: EEV-24-0207	
	PER: 9164	Page #: Page 26 of 28	



YOU ENVISION IT – WE ENGINEER IT

1900 NE Miami Ct., Ste. 2-15
Miami, FL 33132
TEL: 954.399-8478 | FAX: 954.744.4738
WEB: www.buildingdrops.com

9/16" Laminated Glass Capacity

$$\begin{aligned}
 h_1 &= 0.219 \text{ in} \\
 h_2 &= 0.219 \text{ in} \\
 h_v &= 0.060 \text{ in} \\
 h_s &= 0.5(h_1+h_2)+h_v \\
 h_s &= 0.279 \text{ in} \\
 h_{s,1} &= h_{s,2} = (h_s h_1)/(h_1+h_2) \\
 h_{s,1} &= 0.140 \text{ in} \\
 h_{s,2} &= 0.140 \text{ in} \\
 I_s &= h_1 h_{s,2}^2 + h_2 h_{s,1}^2 \\
 I_s &= 0.0085
 \end{aligned}$$



Shortest Dimension (a) (in)	Γ PVB	Γ PVB ES	Γ SGP	$h_{ef,W}$ PVB	$h_{ef,W}$ PVB ES	$h_{ef,W}$ SGP	$h_{1,ef,\sigma}$ PVB	$h_{1,ef,\sigma}$ PVB ES	$h_{1,ef,\sigma}$ SGP
12	0.015	0.051	0.265	0.283	0.297	0.364	0.318	0.335	0.405
24	0.058	0.178	0.590	0.300	0.340	0.433	0.338	0.382	0.461
36	0.121	0.328	0.764	0.322	0.379	0.463	0.364	0.419	0.479
39.75	0.144	0.373	0.798	0.329	0.390	0.468	0.371	0.428	0.482
42	0.158	0.399	0.815	0.334	0.395	0.471	0.376	0.433	0.484
48	0.197	0.464	0.852	0.345	0.409	0.476	0.388	0.443	0.487
60	0.278	0.575	0.900	0.367	0.431	0.484	0.408	0.459	0.490
72	0.356	0.661	0.928	0.386	0.446	0.488	0.425	0.469	0.493

$$\begin{aligned}
 \Gamma &= 1/[1+9.6(EL/h_v)/(Gh^2/a^2)] \\
 \text{effective thickness for deflection:} \\
 h_{ef,W} &= (h_1^3 + h_2^3 + 12\Gamma I_s)^{1/3} \\
 \text{effective thickness for glass stress:} \\
 h_{1,ef,\sigma} &= [h_{ef,W}^3/(h+2\Gamma h_{s,1})]^{1/2}
 \end{aligned}$$

Shortest Dimension (a) (in)	All. Wind Moment (lb-ft) PVB	All. Wind Moment (lb-ft) PVB ES	All. Wind Moment (lb-ft) SGP	All. LL Moment (lb-in/ft) PVB	All. LL Moment (lb-in/ft) PVB ES	All. LL Moment (lb-in/ft) SGP
12	179	199	290	1213	1351	1970
24	202	258	375	1374	1751	2545
36	234	310	405	1586	2107	2753
39.75	244	323	411	1655	2197	2788
42	250	331	413	1697	2245	2806
48	266	347	418	1804	2358	2842
60	294	372	425	2000	2525	2886
72	319	388	429	2165	2636	2911

$$\begin{aligned}
 M_{GL} &= 6,000\text{psi} \cdot 2 \cdot h_{1,ef,\sigma}^2 = 12,000 h_{1,ef,\sigma}^2 \text{ ''#/ft} = 1,000 h_{1,ef,\sigma}^2 \text{ ''#/ft} \text{ For Live Loads} \\
 M_{EW} &= 9,600\text{psi} \cdot 2 \cdot h_{1,ef,W}^2 \text{ For Wind Loads}
 \end{aligned}$$

Glass Panel Loads
From IBC 1607.7.1

Light Width (in)	Max. Panel Height Live Loads (in.)					
	50 plf PVB	50 plf PVB ES	50 plf SGP	200 lb PVB	200 lb PVB ES	200 lb SGP
12	24.25	27.01	39.40	48.50	54.02	78.80
24	27.48	35.03	50.90	109.94	140.11	203.59
36	31.73	42.15	55.07	190.37	252.90	330.39
39.75	33.11	43.93	55.77	219.34	291.06	369.47
42	33.93	44.90	56.11	237.52	314.33	392.80
48	36.07	47.16	56.83	288.58	377.28	454.67
60	39.99	50.49	57.72	399.91	504.90	577.20
72	43.30	52.72	58.22	519.58	632.59	698.66

For 50 plf distributed load:
 $h = (M_{GL}/U) = M_{GL}/50\text{plf}$

For 200# load, not top rail:
 $h = M_{GL} \cdot S / 200\#$ where S = light length in feet when installed with cap rail
For installation without a cap rail and load at corner of glass:
 $h = M_{GL} \cdot (2/3 \cdot S) / 200\#$ where S ≤ h

Project Description: Glass Warehouse LLC / Future Glass RAN-CHRES Base Shoe Engineering Analysis	Date: January 30, 2025	Customer: Glass Warehouse LLC / Future Glass	
	Engineer: SH	Project #: EEV-24-0207	
	PER: 9164	Page #: Page 27 of 28	



YOU ENVISION IT – WE ENGINEER IT

1900 NE Miami Ct., Ste. 2-15
 Miami, FL 33132
 TEL: 954.399-8478 | FAX: 954.744.4738
 WEB: www.buildingdrops.com

1 1/16" Laminated Glass Capacity

$$\begin{aligned}
 h_1 &= 0.292 \text{ in} \\
 h_2 &= 0.292 \text{ in} \\
 h_v &= 0.060 \text{ in} \\
 h_s &= 0.5(h_1+h_2)+h_v \\
 h_s &= 0.352 \text{ in} \\
 h_{s,1} = h_{s,2} &= (h_s h_1)/(h_1+h_2) \\
 h_{s,1} &= 0.176 \text{ in} \\
 h_{s,2} &= 0.176 \text{ in} \\
 I_s &= h_1 h_{s,2}^2 + h_2 h_{s,1}^2 \\
 I_s &= 0.0181
 \end{aligned}$$



Shortest Dimension (a) (in)	Γ PVB	Γ PVB ES	Γ SGP	$h_{def,W}$ PVB	$h_{def,W}$ PVB ES	$h_{def,W}$ SGP	$h_{1,def,\sigma}$ PVB	$h_{1,def,\sigma}$ PVB ES	$h_{1,def,\sigma}$ SGP
12	0.011	0.039	0.212	0.374	0.388	0.458	0.420	0.437	0.511
24	0.044	0.140	0.519	0.390	0.431	0.546	0.439	0.485	0.585
36	0.094	0.268	0.708	0.413	0.476	0.588	0.465	0.529	0.613
39.75	0.112	0.308	0.748	0.420	0.489	0.596	0.473	0.540	0.618
42	0.124	0.332	0.768	0.425	0.496	0.600	0.478	0.546	0.620
48	0.156	0.394	0.812	0.437	0.513	0.609	0.491	0.560	0.625
60	0.224	0.504	0.871	0.462	0.542	0.620	0.515	0.582	0.632
72	0.293	0.594	0.907	0.484	0.563	0.627	0.536	0.597	0.635

$\Gamma = 1/[1+9.6(EI_s h_v)/(Gh^3 a^2)]$
 effective thickness for deflection:
 $h_{def,W} = (h_1^3 + h_2^3 + 12\Gamma I_s)^{1/3}$
 effective thickness for glass stress:
 $h_{1,def,\sigma} = [h_{def,W}^3 / (h + 2\Gamma h_{s,1})]^{1/2}$

Shortest Dimension (a) (in)	All. Wind Moment (lb-ft) PVB	All. Wind Moment (lb-ft) PVB ES	All. Wind Moment (lb-ft) SGP	All. LL Moment (lb-in/ft) PVB	All. LL Moment (lb-in/ft) PVB ES	All. LL Moment (lb-in/ft) SGP
12	312	337	462	2119	2287	3138
24	341	415	605	2316	2818	4107
36	381	494	664	2591	3352	4512
39.75	395	515	675	2685	3497	4584
42	404	527	680	2741	3577	4620
48	426	555	691	2892	3770	4696
60	469	599	705	3183	4069	4788
72	507	630	713	3445	4280	4842

$M_{dL} = 6,000\text{psi} \cdot 2 \cdot h_{1,def,\sigma}^2 = 12,000 h_{1,def,\sigma}^2$ "/ft = $1,000 h_{1,def,\sigma}^2$ "/ft For Live Loads
 $M_{dW} = 9,600\text{psi} \cdot 2 \cdot h_{1,def,\sigma}^2$ For Wind Loads

Glass Panel Loads
 From IBC 1607.7.1

Light Width (in)	Max. Panel Height Live Loads (in.)					
	50 plf PVB	50 plf PVB ES	50 plf SGP	200 lb PVB	200 lb PVB ES	200 lb SGP
12	42.38	45.74	62.76	84.76	91.47	125.53
24	46.33	56.36	82.14	185.31	225.44	328.57
36	51.82	67.04	90.25	310.94	402.26	541.49
39.75	53.69	69.93	91.68	355.70	463.30	607.40
42	54.82	71.54	92.40	383.77	500.79	646.77
48	57.85	75.39	93.89	462.79	603.16	751.15
60	63.67	81.38	95.77	636.69	813.82	957.70
72	68.89	85.60	96.85	826.72	1027.16	1162.15

For 50 plf distributed load:
 $h = (M_{dL}/t) = M_{dL}/50\text{plf}$

For 200# load, not top rail:
 $h = M_{dL} \cdot S / 200\#$ where S = light length in feet when installed with cap rail
 For installation without a cap rail and load at corner of glass:
 $h = M_{dL} \cdot (2/3 \cdot S) / 200\#$ where S ≤ h

Project Description: Glass Warehouse LLC / Future Glass RAN-CHRES Base Shoe Engineering Analysis	Date: January 30, 2025	Customer: Glass Warehouse LLC / Future Glass	
	Engineer: SH	Project #: EEV-24-0207	
	PER: 9164	Page #: Page 28 of 28	