

Jumbo Hinge Pin Door Stop, 10-Pack
Satin Nickel

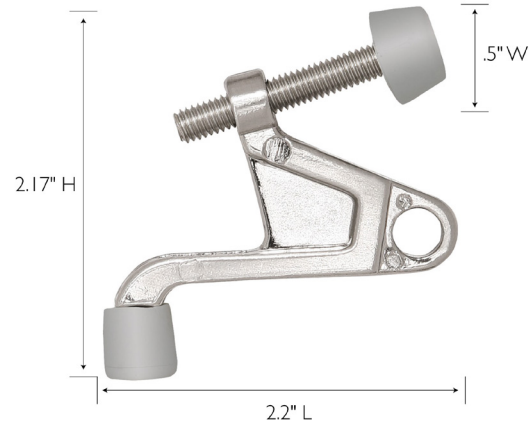

SPECIFICATIONS

MATERIAL CONSTRUCTION:	Zinc
MOUNTING HARDWARE INCLUDED:	Yes
ASSEMBLED DIMENSIONS:	2.17" H x 2.2" L x .5" W
ASSEMBLED WEIGHT:	.68 lbs.

WARRANTY:	1-Year limited warranty
LEGAL FOR SALE IN CALIFORNIA:	Yes



TYPE: JOB: ORDER CODE: APPROVALS:
--