

INSTRUCTION MANUAL

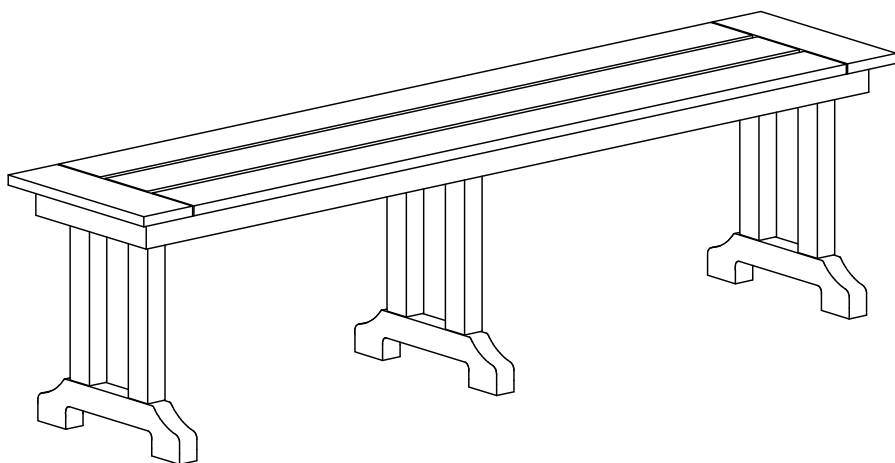

Laguna Trestle 65" Bench
SKU:OP2007

V1.0

! NOTICE

Do not overtighten screws. (Insert all screws before tighten screws.)

- Please do not exceed the weight limitations of this item.
- Do not stand on or use any part of this item as a step ladder.
- Firmly secure all bolts, screws and nuts before use.
- Reconfirm that all bolts, screws, and nuts are secure every 90 days.
- Do not use or store this item in the proximity of open flame or flammable/combustible chemicals.
- Be aware that some parts are heavy and have sharp edges.
- Please adjust the speed slowly when you use electric drill for assembling to avoid screw slippage.

TOOLS REQUIRED



ALLEN WRENCH
(PROVIDED)



WRENCH
(PROVIDED)



BENCH
660 LBS
CAPACITY



1 PERSON
ASSEMBLY



UP TO 20 MIN.
ASSEMBLY

HARDWARE

1 M6 x100mm
BOLT



6 PCS

2 M6 x95mm
BOLT



6 PCS

3 M6.3 x80mm
BOLT

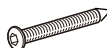

6 PCS

4 M6 NUT



12 PCS

5 M6 WASHER



12 PCS

6 ALLEN
WRENCH



1 PC

7 WRENCH

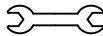

1 PC

8 SCREWDRIVER
BLADES



1 PC

PARTS

A BENCH TOP

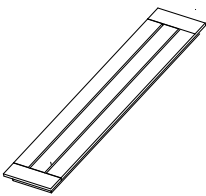

1 PC

B BENCH LEG

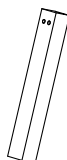

6 PCS

C BENCH
BOTTOM FEET

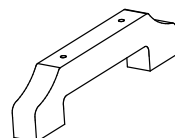

3 PCS

PRODUCT ASSEMBLY-OVERALL VIEW

1

Look at following overall view of this bench and exact position of each parts to be assembled

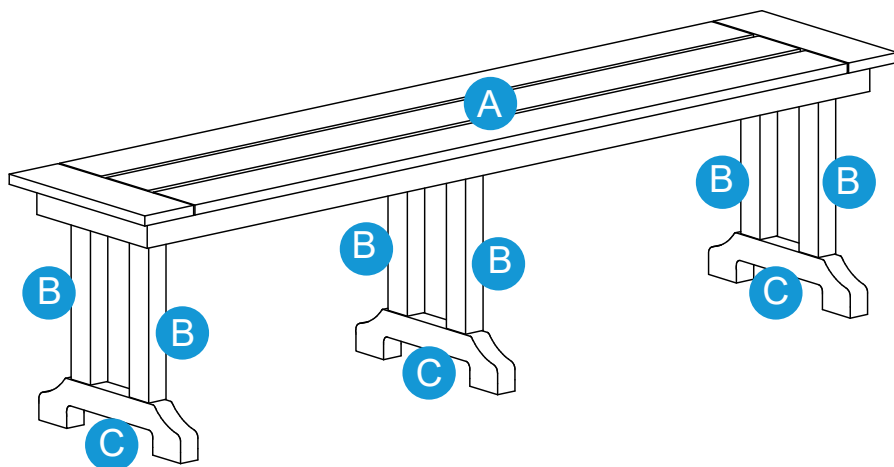

PRODUCT ASSEMBLY

1

Attach part C Bench Bottom Feet to part B Bench Leg with 6 pcs of Hardware 3 Bolt.

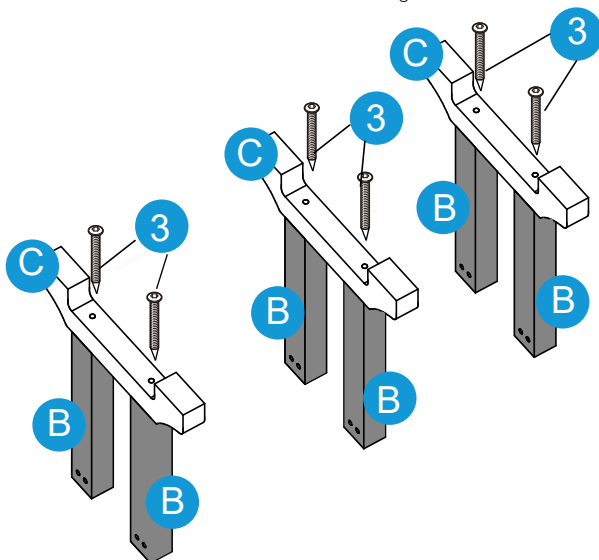

PRODUCT ASSEMBLY

2

Attach part B Bench Leg to part A Bench Top with 6 pcs of hardware 2 bolt, 4 nut and 5 washer.

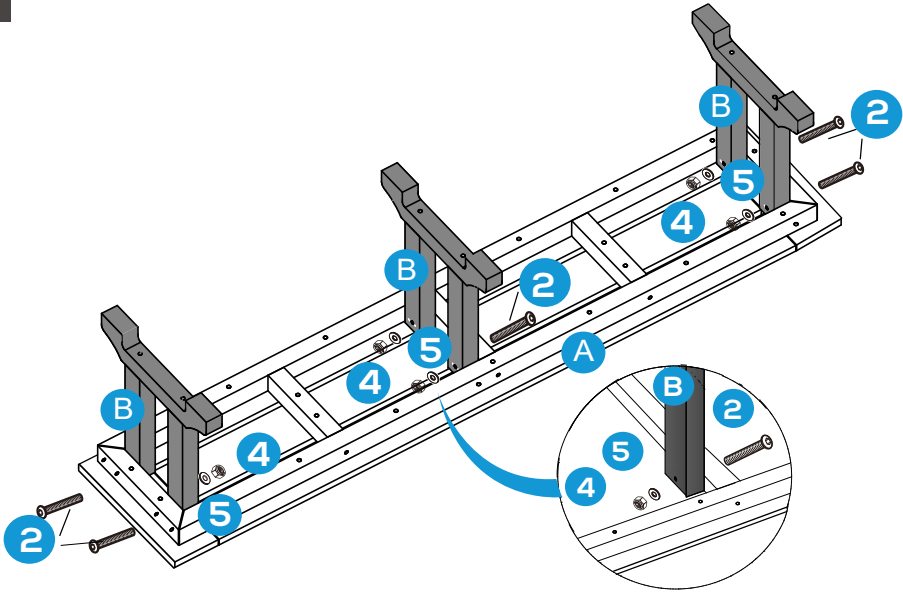

3

Strengthening part B Bench Leg and part A Bench Top with 6 pcs of Hardware 1 bolt, 4 nut and 5 washer.

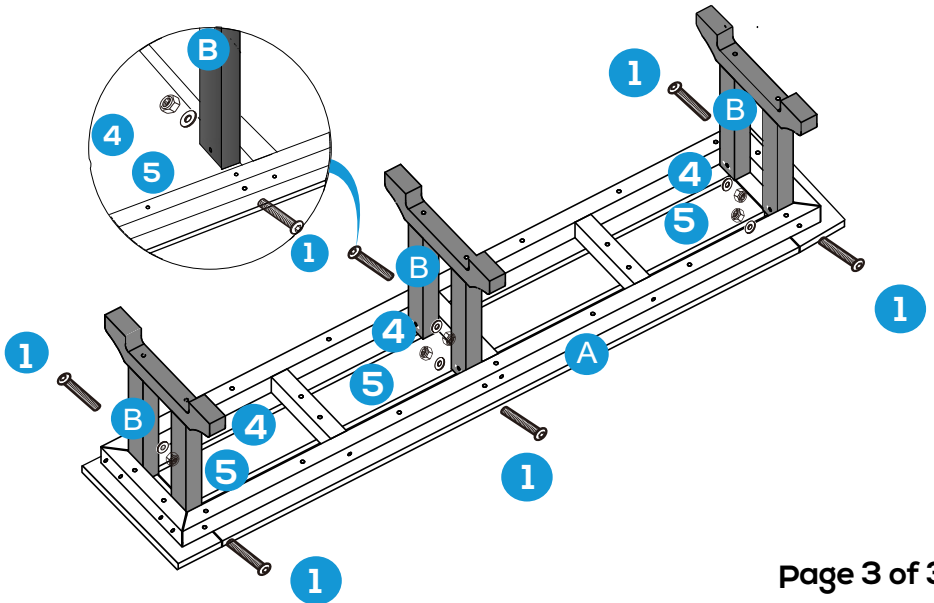

Check and tighten all the bolts and screws again and finish the assembly.

