



Street Vendor Popcorn Machines and Cart

Models: 11040, 11060, and 11080

Take a walk down memory lane with "Street Vendor". Styled after old-time boardwalks of Coney Island and Palisades Park, they remind of an era when vendors sold popcorn on street corners all across America.

Standard Features

- ◆ Easy to use, simple two-switch operation
- ◆ Built-in heated warming deck
- ◆ 50 Watt warmer light (bulb included)
- ◆ Old-maid drawer catches unpopped kernels
- ◆ Stainless steel food-zone for easy cleaning
- ◆ Thick 20 mil non-stick coated popping kettle
- ◆ Tempered glass panels on front and side
- ◆ Front or rear mount decorative cornice
- ◆ Clear removable plexiglass doors at rear
- ◆ Non-slip rubber feet
- ◆ One year parts and labor warranty



Accessories and Options

30010	Cart/Trolley for Street Vendor Popcorn Machines
42030	Aluminum Speed Scoop
42020	Plastic Popcorn Scoop -16 oz
40004	4 oz Popcorn Portion Packs - 24 packs/case
40006	6 oz Popcorn Portion Packs - 24 packs/case
40008	8 oz Popcorn Portion Packs - 24 packs/case

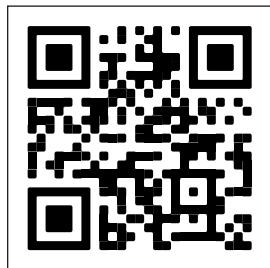

Visit www.wincous.com for Popcorn Supplies

Project _____
 Item # _____
 Quantity _____



Front

Rear

11040 - 4oz
 11060 - 6oz
 11080 - 8oz



30010 Street Vendor Cart with 11060 Popcorn Machine

For California Customers
 ⚠️ **WARNING:** Cancer and Reproductive Harm - www.P65Warnings.ca.gov

Winco® | Division of The Foodware Group™

www.wincous.com

New Jersey Headquarters & Distribution Center
 65 Industrial Road, Lodi, NJ 07644
 Phone: 1-888-946-2682 | Fax: 1-973-916-9959

Florida Showroom & Distribution Center
 10800 NW 103rd St. Bldg 22, Ste 11, Miami, FL 33178
 Phone: 1-888-946-2682 | Fax: 1-973-916-9959

Nevada Distribution Center
 3777 Marion Drive, Las Vegas, NV 89115
 Phone: 1-888-946-2682 | Fax: 1-973-916-9959



Street Vendor Popcorn Machines and Cart

Models: 11040, 11060, 11080, and 30010

BACK VIEW

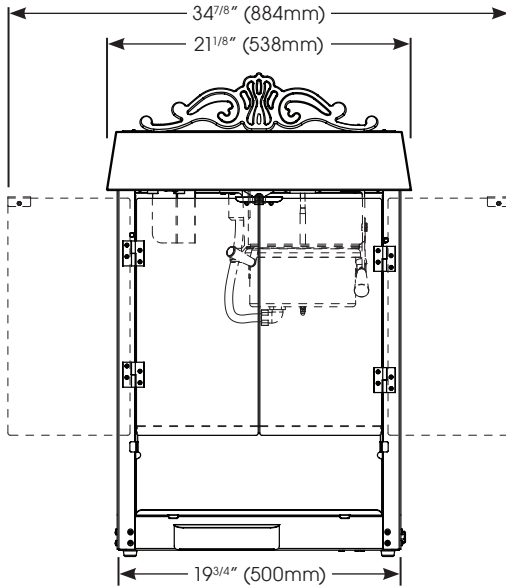

SIDE VIEW

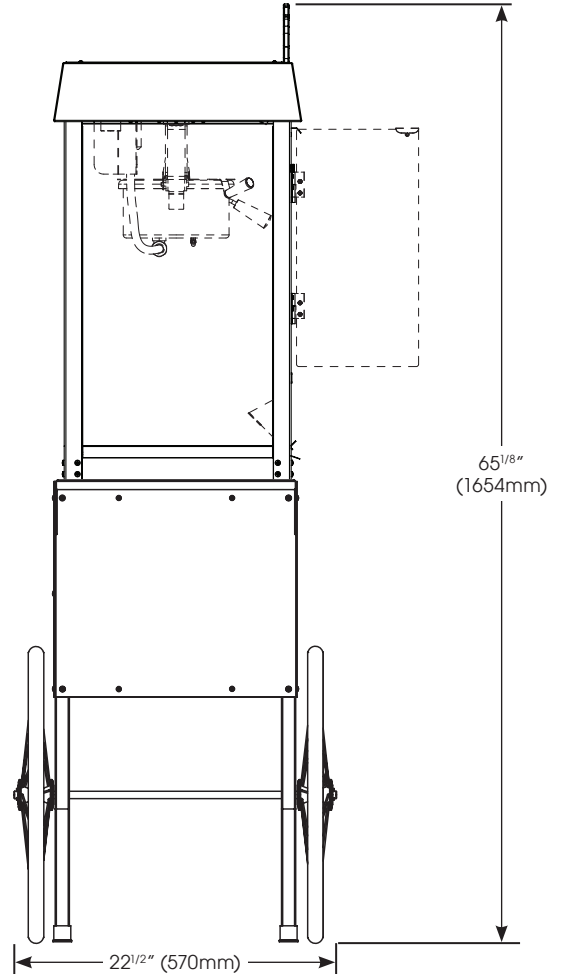
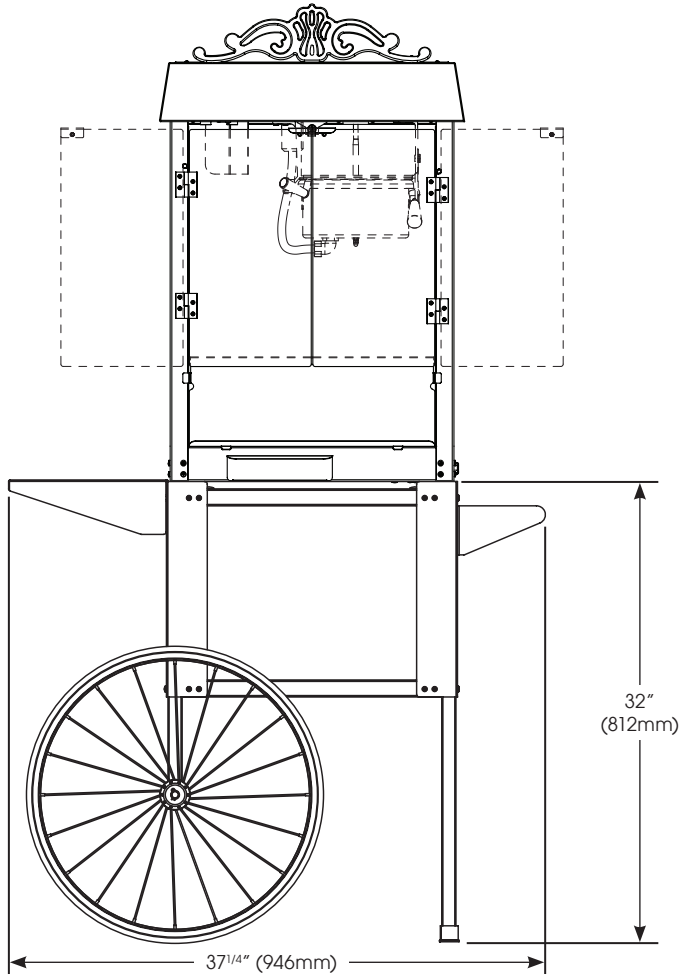
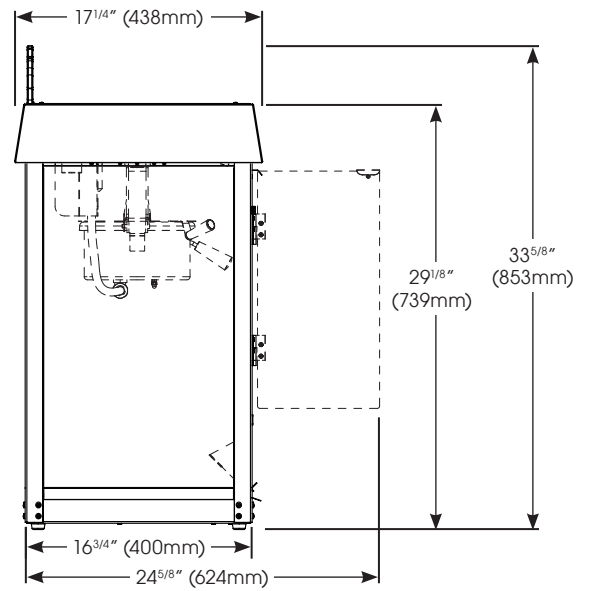

Winco® | Division of The Foodware Group™

www.wincous.com

New Jersey Headquarters & Distribution Center
65 Industrial Road, Lodi, NJ 07644
Phone: 1-888-946-2682 | Fax: 1-973-916-9959

Florida Showroom & Distribution Center
10800 NW 103rd St. Bldg 22, Ste 11, Miami, FL 33178
Phone: 1-888-946-2682 | Fax: 1-973-916-9959

Nevada Distribution Center
3777 Marion Drive, Las Vegas, NV 89115
Phone: 1-888-946-2682 | Fax: 1-973-916-9959



Street Vendor Popcorn Machines and Cart

Models: 11040, 11060, 11080, and 30010

MODEL	DESCRIPTION	OVERALL DIMENSIONS			VOLTS	HZ	WATTS	AMPS	PLUG	SHIP WEIGHT
		LENGTH	DEPTH	HEIGHT						
11040	4 oz Kettle	21-1/8" 538mm	17-1/4" 438mm	33-5/8" 853mm	120 V	60 Hz	1040 W	8.6 A	NEMA 5-15P	62 lbs (28.1 kgs)
11060	6 oz Kettle				120 V	60 Hz	1240 W	10.3 A	NEMA 5-15P	64 lbs (29 kgs)
11080	8 oz Kettle				120 V	60 Hz	1490 W	12.4 A	NEMA 5-15P	66 lbs (30 kgs)
30010	Street Vendor Cart	37-1/4" 946mm	22-1/2" 570mm	32" 812mm					44 lbs (20 kg)	

Plug Configurations

NEMA 5-15P

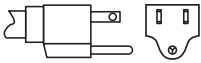

Cord Location

Back left side or operator's side right

Bulb Type

50 Watt R20

Product Specs

Street Vendor Popcorn Machines

The Benchmark USA Street Vendor Popcorn Machines models 11040, 11060, and 11080 as manufactured by Winco®, Lodi, NJ 07644

The Street Vendor Popcorn Machine model 11040 shall have a 4 oz kettle capacity be rated at 1040W, 120V-60Hz, model 11060 shall have a 6 oz kettle capacity be rated at 1240W, 120V-60Hz, and 11080 shall have a 8 oz kettle capacity be rated at 1490W. Kettles are constructed with a thick 20 mil non-stick coating. All units shall be supplied with a NEMA 5-15P plug.

Units cabinet shall be constructed of a stainless steel, aluminum, powder coated painted accent panels with tempered glass panels on front and side and clear plexiglass doors at rear. Units are supplied with easy to use, simple two-switch operation, 50 Watt warmer light (bulb included), old-maid drawer to catch unpopped kernels,

CE certified and ETL listed for safety (Canada & US) and sanitation.

Warranty consists of one year parts and labor.