

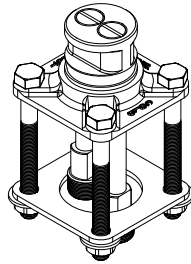

Installation guide / Guide d'installation / Guía de Instalación



Before initiating the installation:

Read all instructions.

Purge the water supply system before connecting it to the faucet.

Note for xx37 models:

Depending of the area, the installation of an "on demand" water heater may not be recommended with this system.

Avant de commencer l'installation:

Lire toutes les instructions.

Purger votre système d'alimentation d'eau avant d'effectuer le branchement au robinet.

Note pour les modèles xx37:

Selon la région, l'installation de ce système est déconseillée avec un chauffe-eau "sur demande".

Antes de iniciar la instalación:

Lea todas las instrucciones.

Es necesario purgar previamente su sistema de alimentación de agua para efectuar la conexión del grifo.

Nota para los modelos xx37:

Según la región, la instalación de este sistema es desaconsejada con un calentador de agua "a petición".

Note for xx37 models :

Depending of the area, the installation of an "on demand" water heater may not be recommended with this system.

Tools and equipment requested / Outils et matériels requis / Herramientas y material requerido de instalación



WHITE
BLANC
BLANCO



riobel.ca

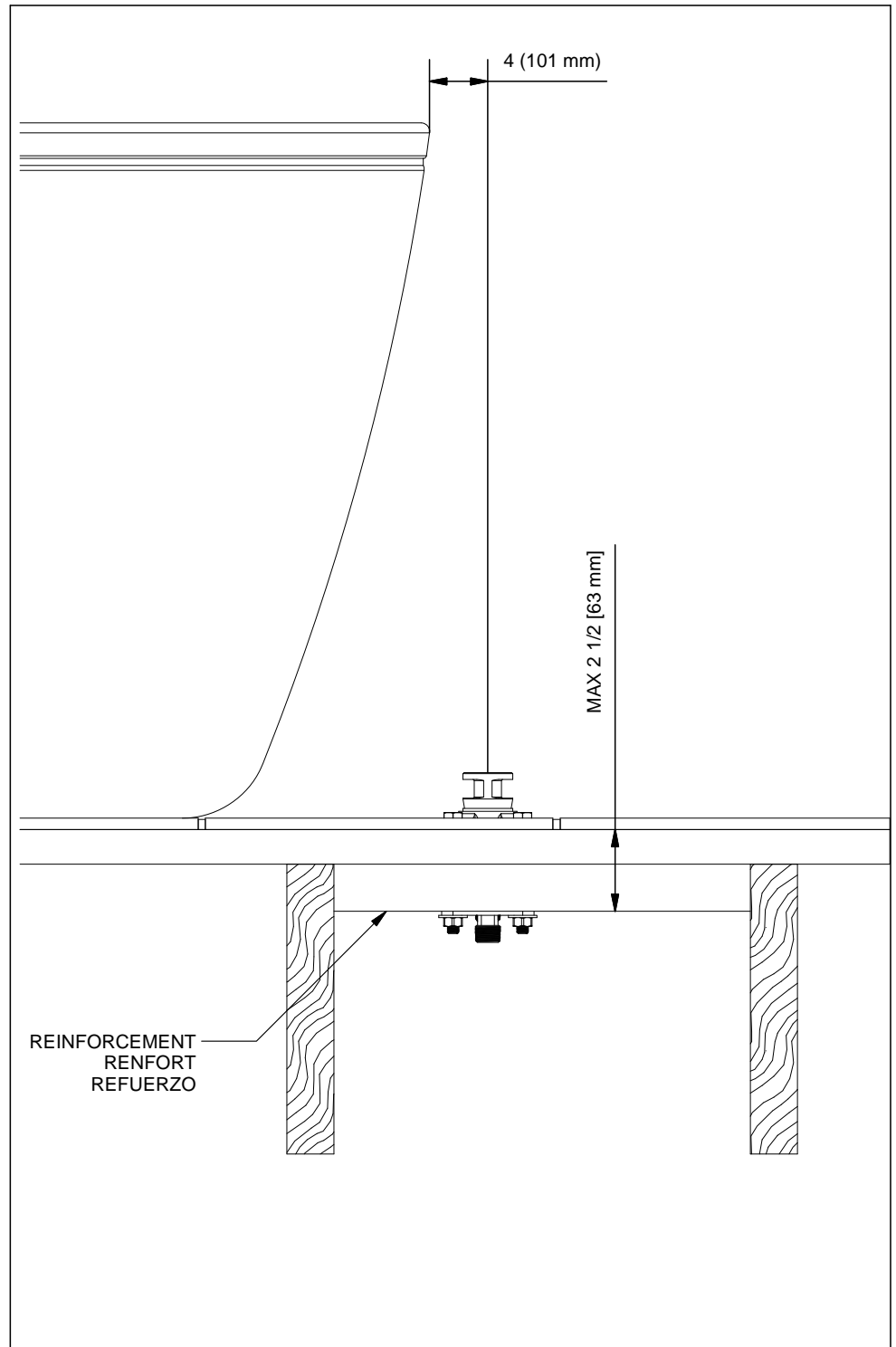

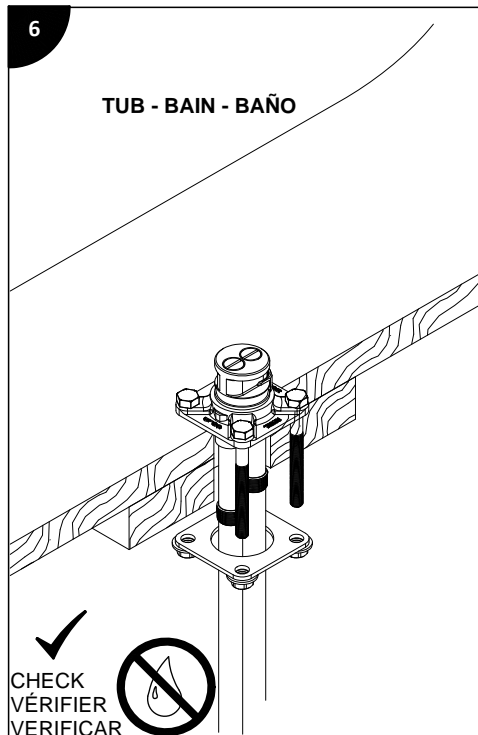
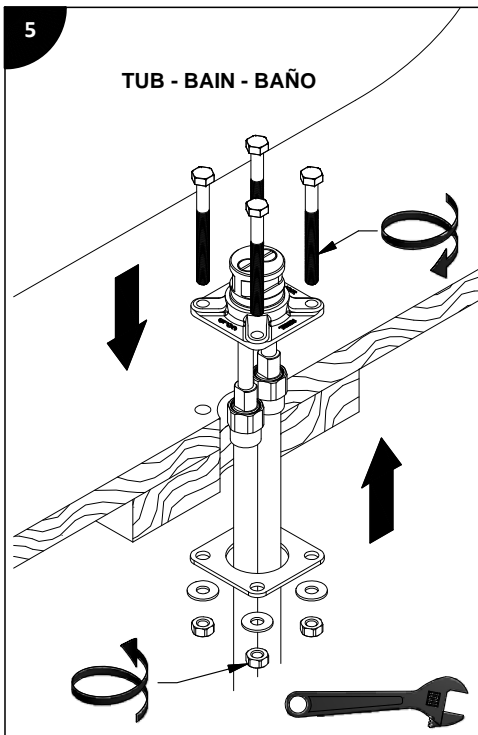
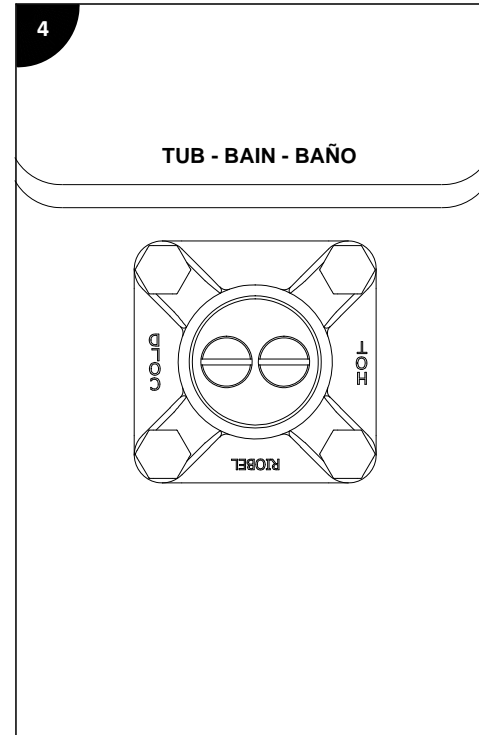
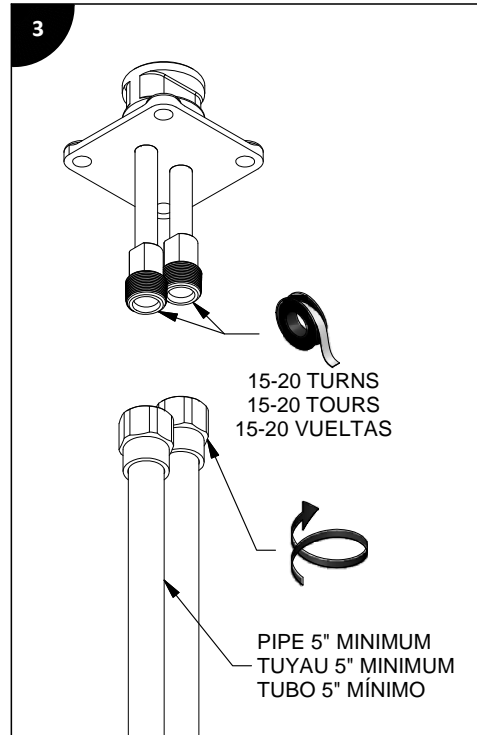
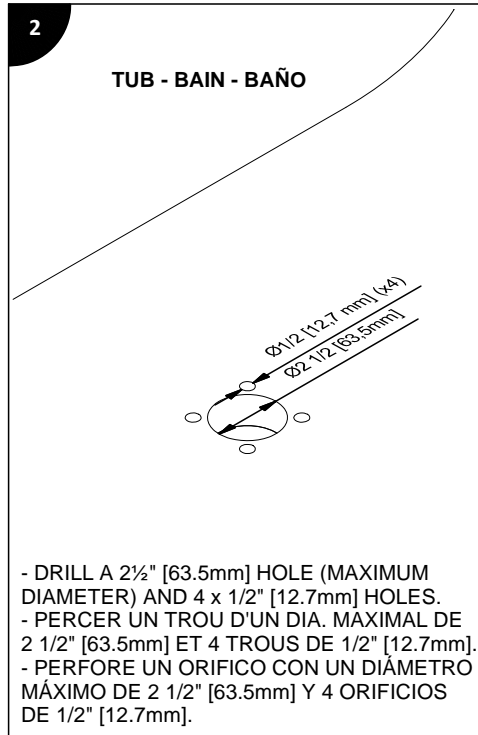
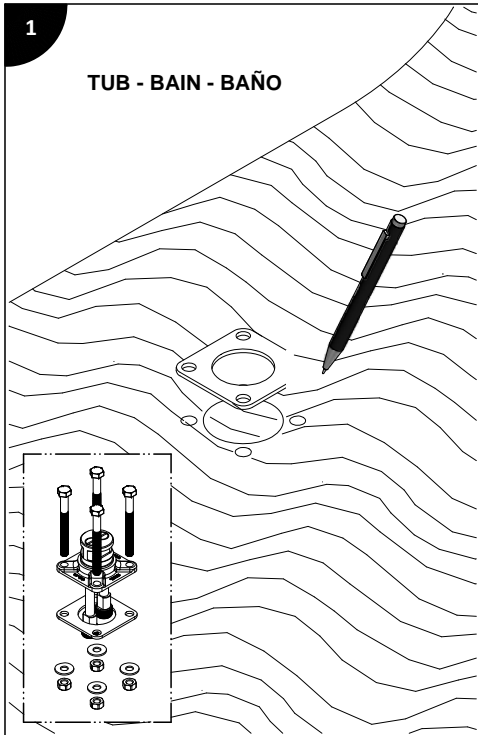



Installation guide / Guide d'installation / Guía de instalación

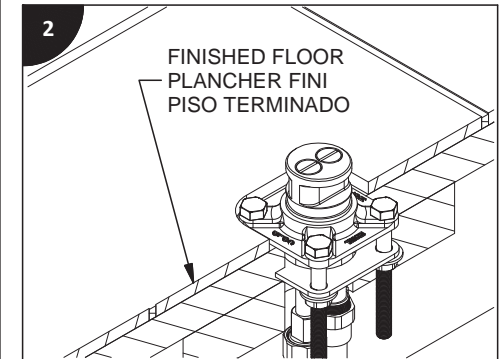
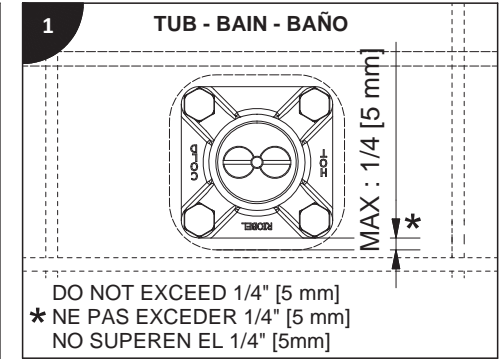
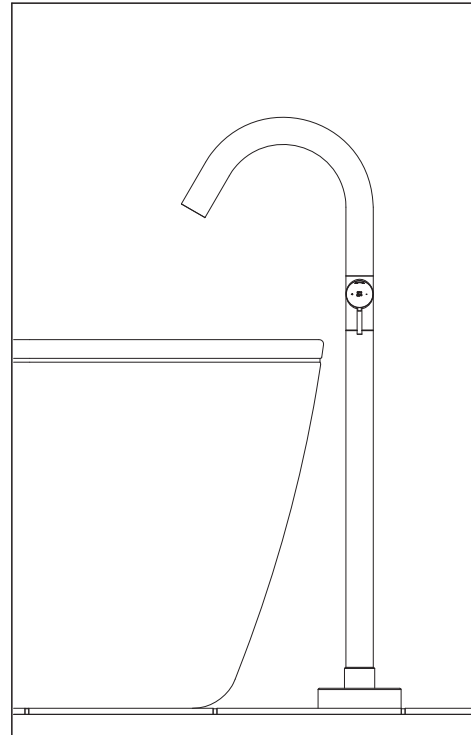
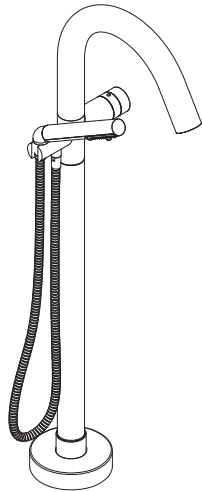

Before beginning the installation:

Read all instructions.

Purge the water supply system before connecting it to the faucet.

Avant de commencer l'installation:

Lire toutes les instructions.

Purger votre système d'alimentation d'eau avant d'effectuer le branchement au robinet.

Antes de iniciar la instalación:

Lea todas las instrucciones.

Es necesario purgar previamente su sistema de alimentación de agua para efectuar la conexión del grifo.

Tools and equipment required / Outils et matériel requis / Herramientas y material requerido para instalación:

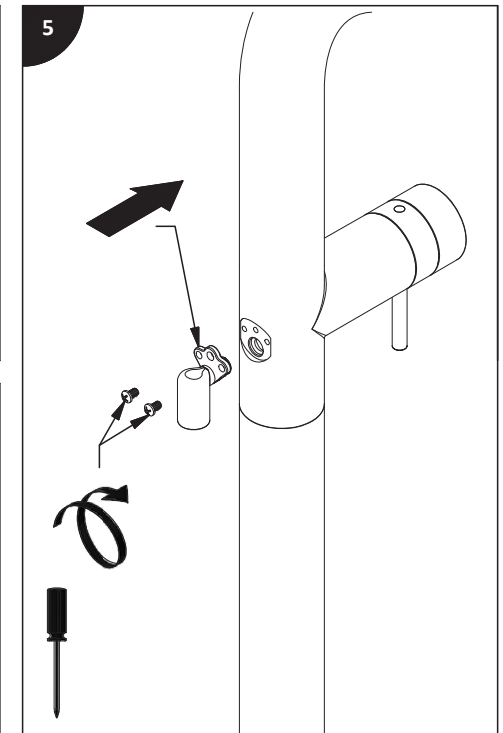
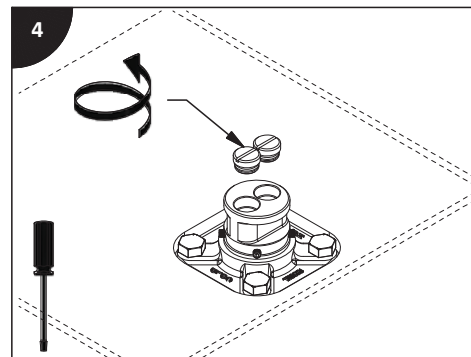
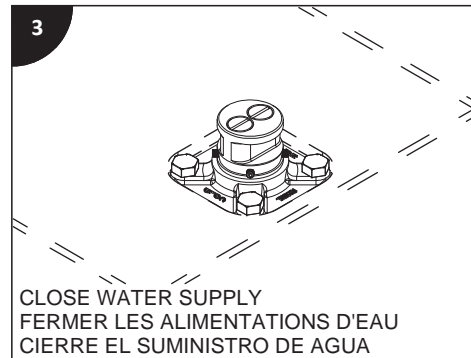

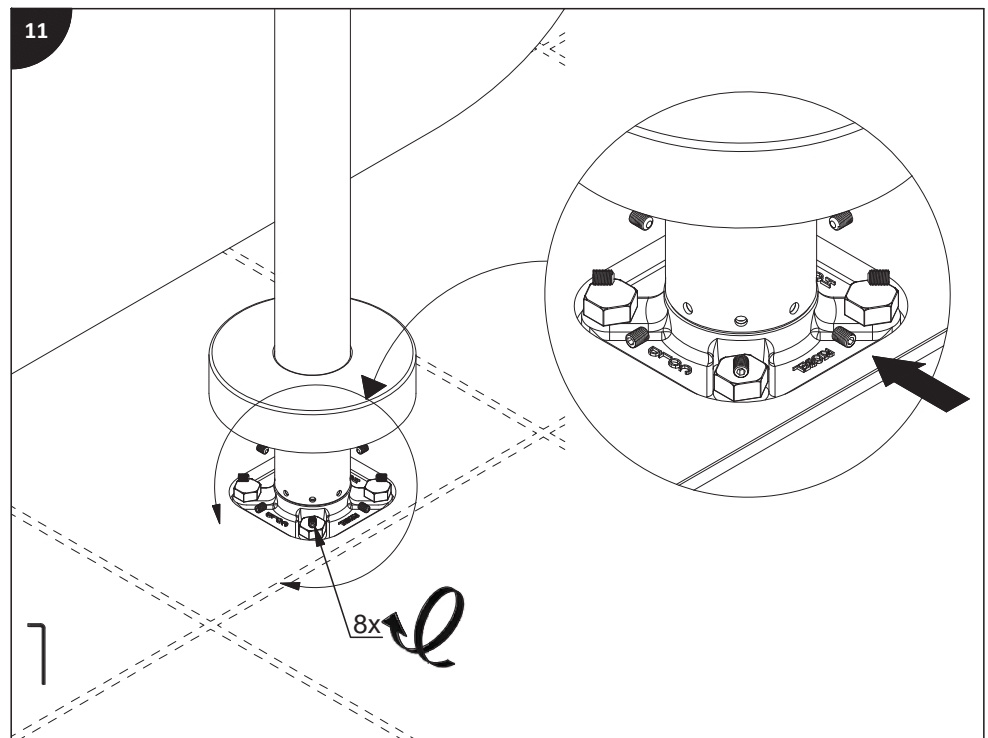
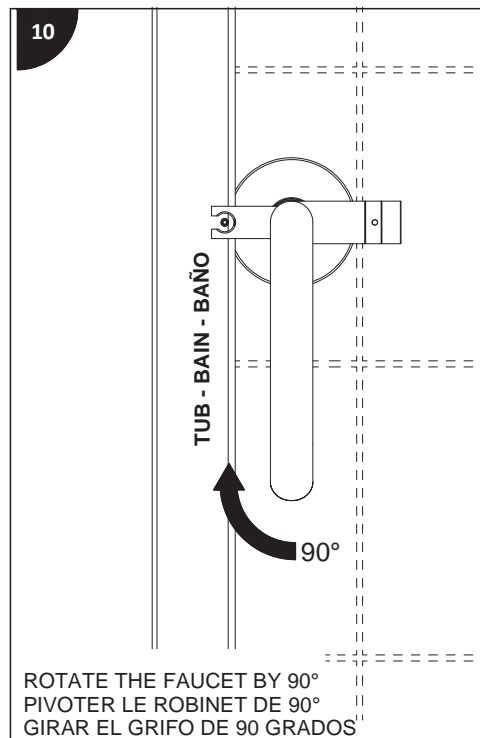
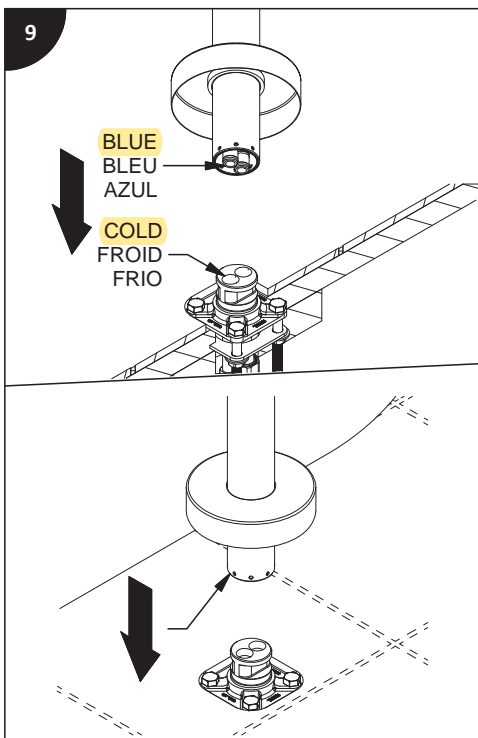
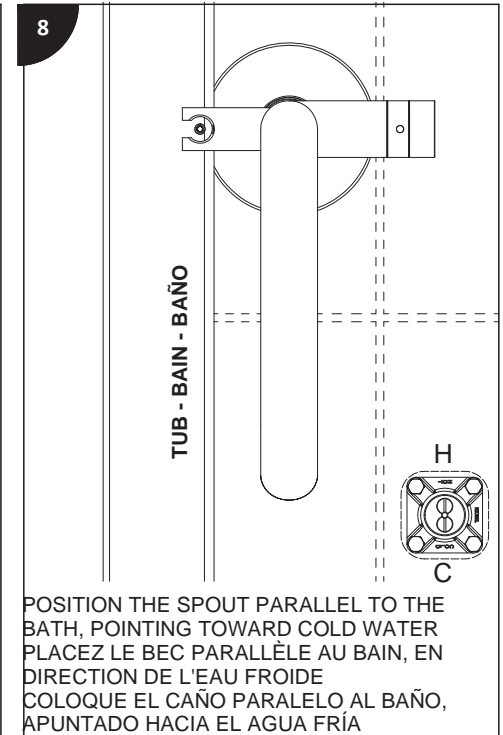
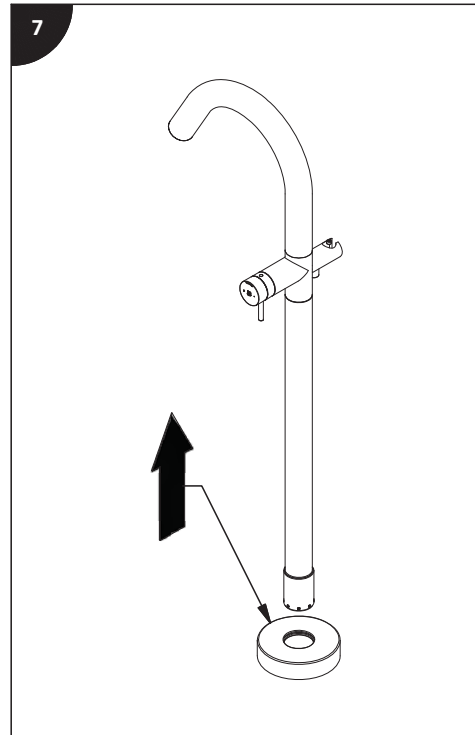
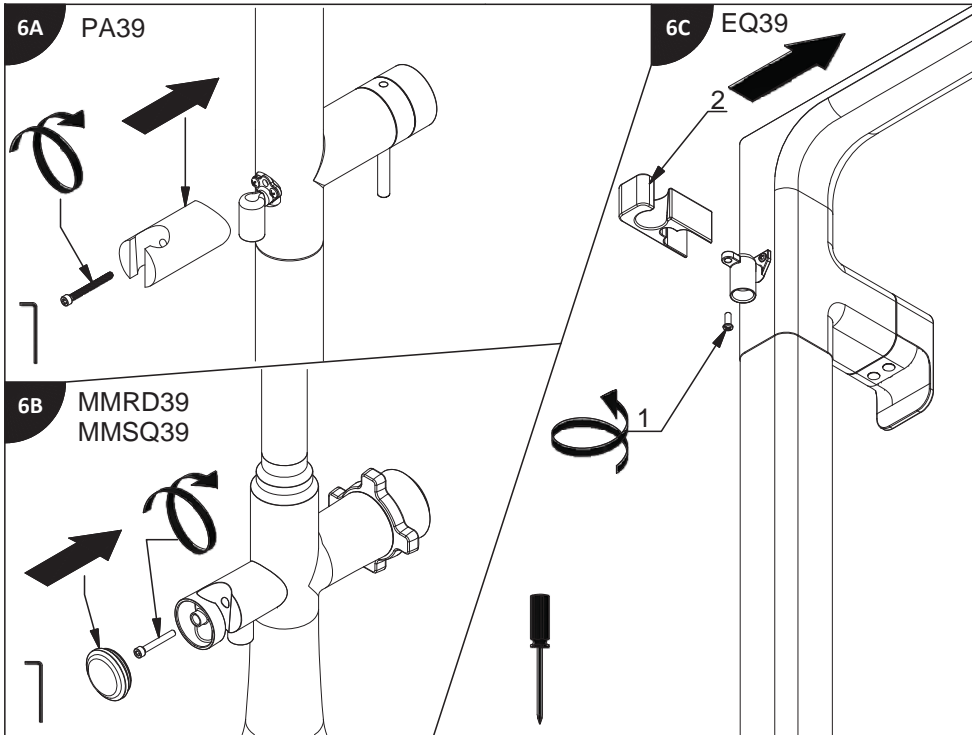

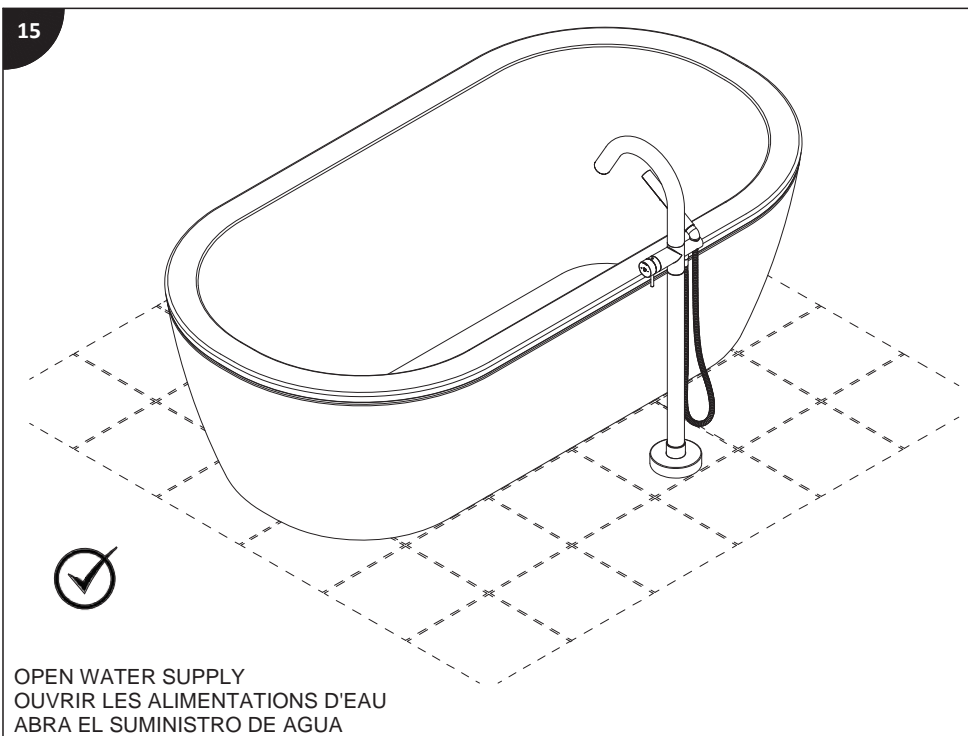
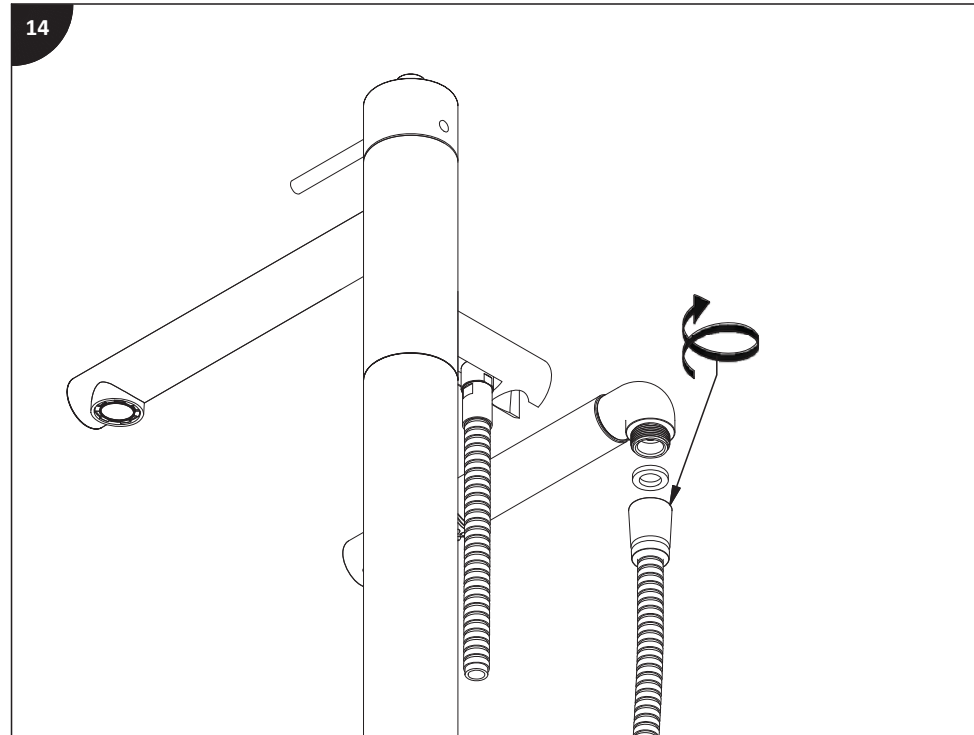
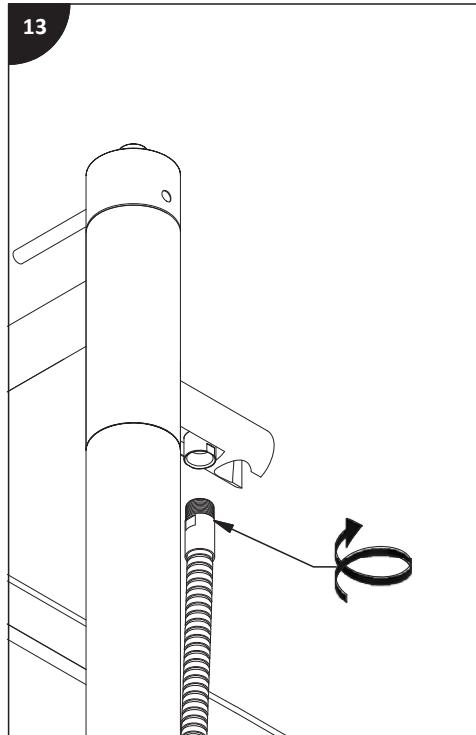
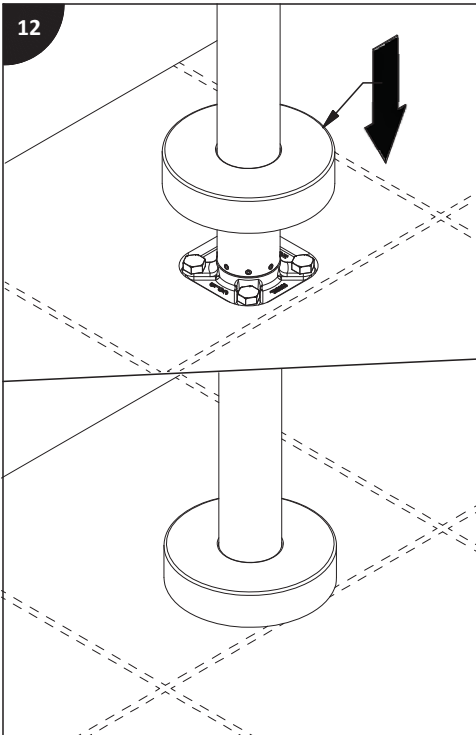



Installation guide / Guide d'installation / Guía de instalación

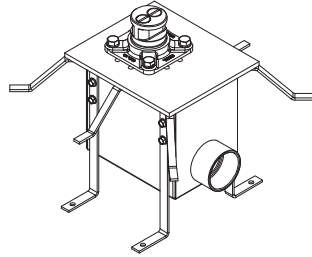
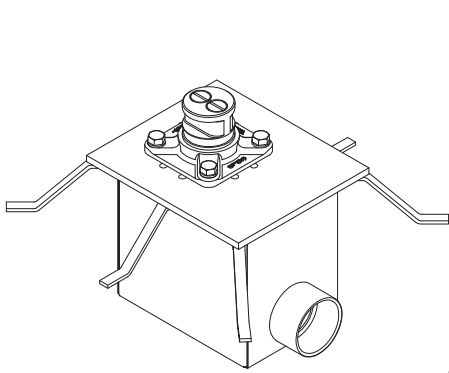

L'ensemble des tiges d'ajustement est
vendu séparément
The adjustment rod kit is sold
separately
Todas las varillas des ajuste se venden
separado

Before beginning the installation:

Read all instructions.
Purge the water supply system before connecting it to the faucet.

Avant de commencer l'installation:

Lire toutes les instructions.
Purger votre système d'alimentation d'eau avant d'effectuer le branchement au robinet.

Antes de iniciar la instalación:

Lea todas las instrucciones.
Es necesario purgar previamente su sistema de alimentación de agua para efectuar la conexión del grifo.

Tools and equipment required / Outils et autre matériel requis / Herramientas y otros equipos para la instalación :

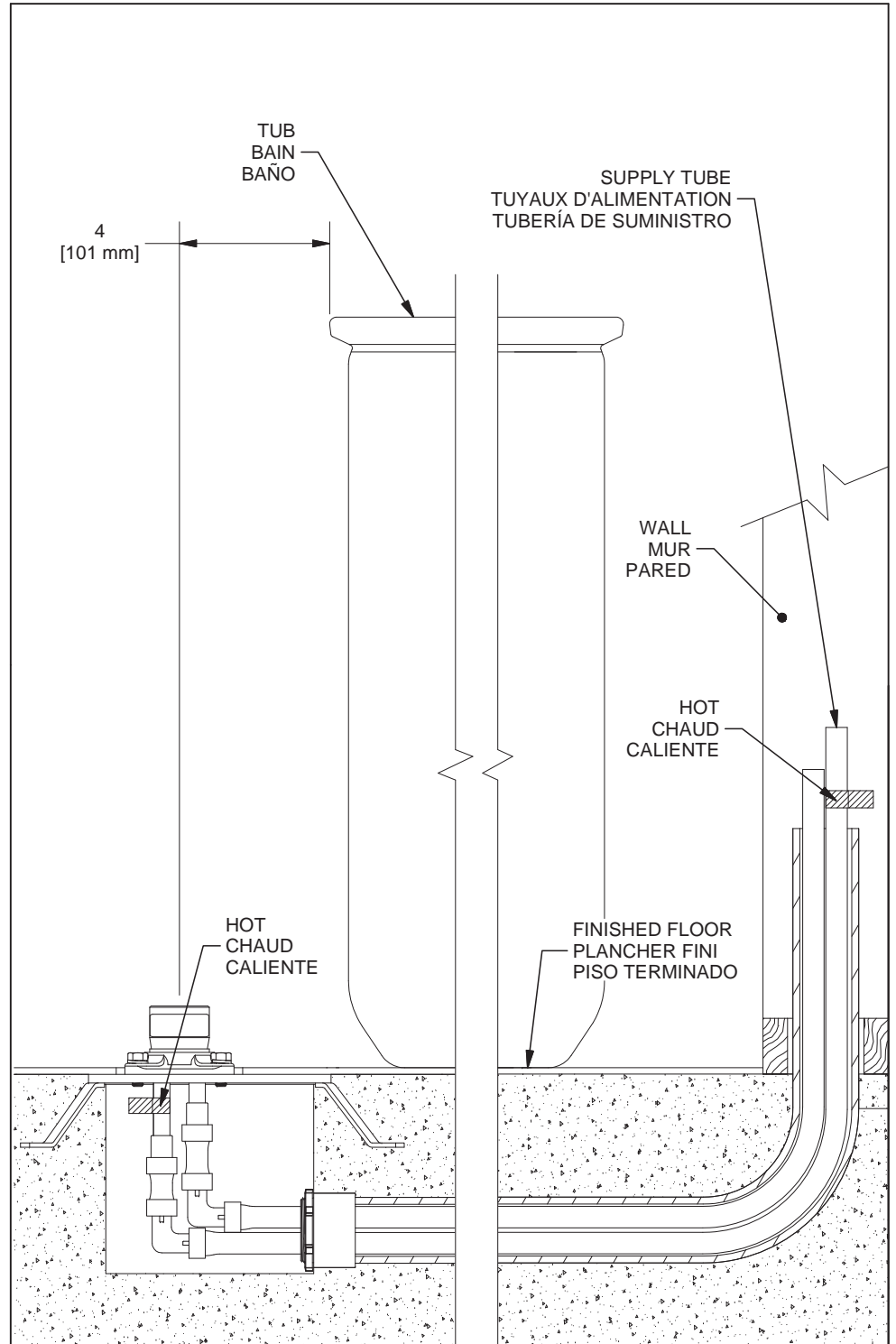

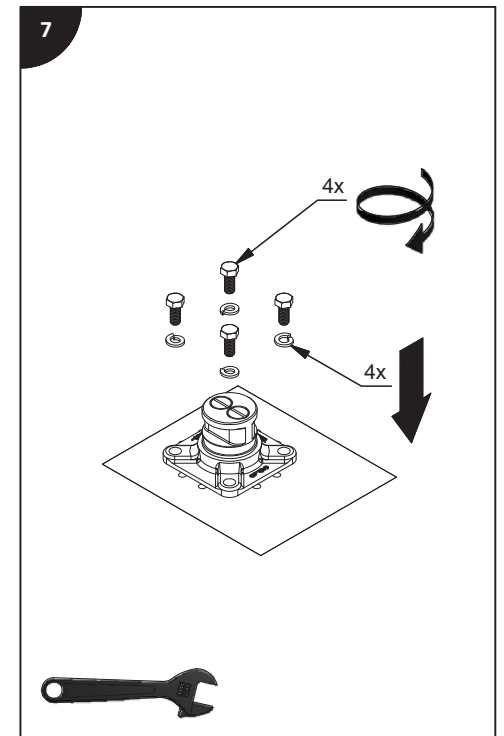
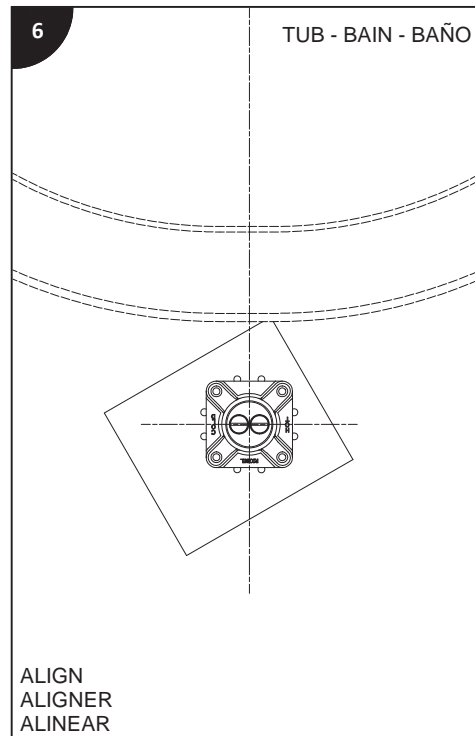
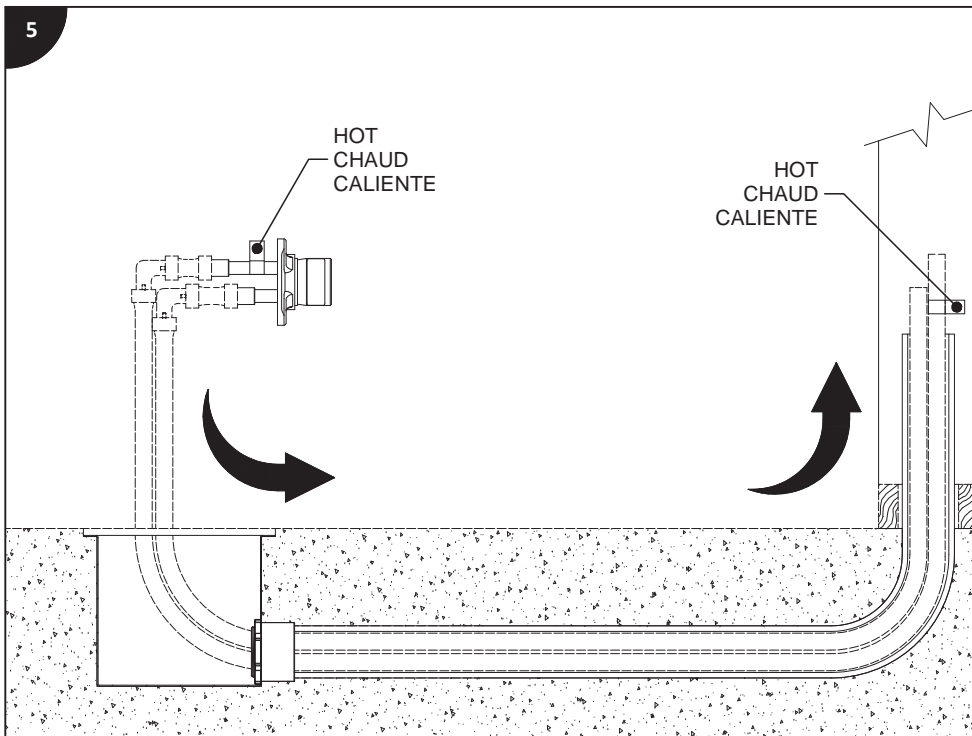
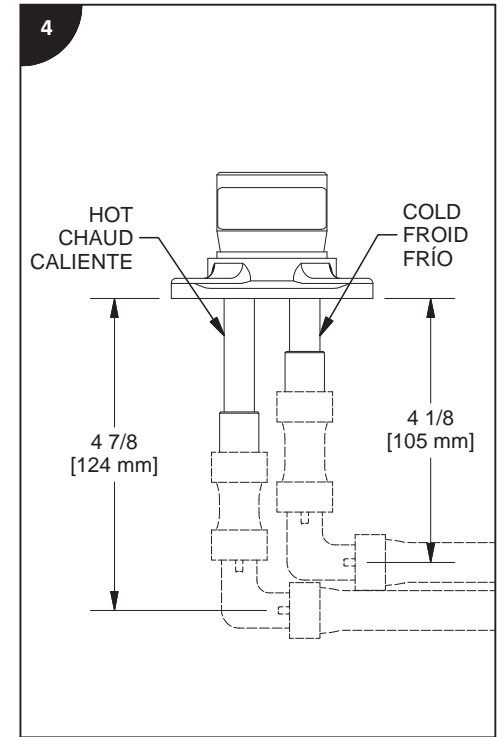
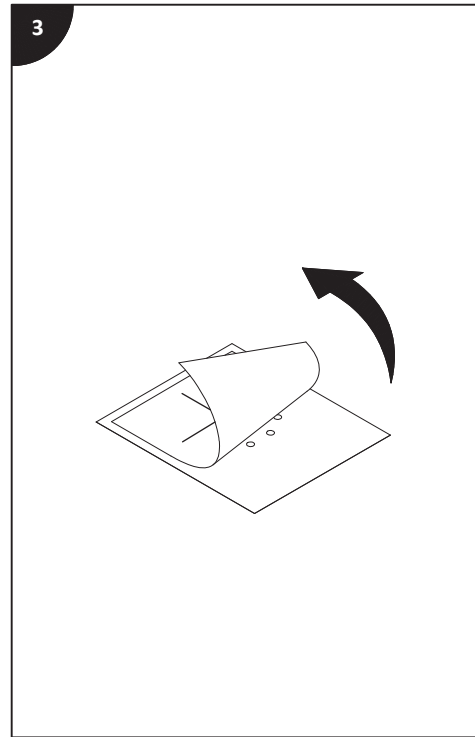
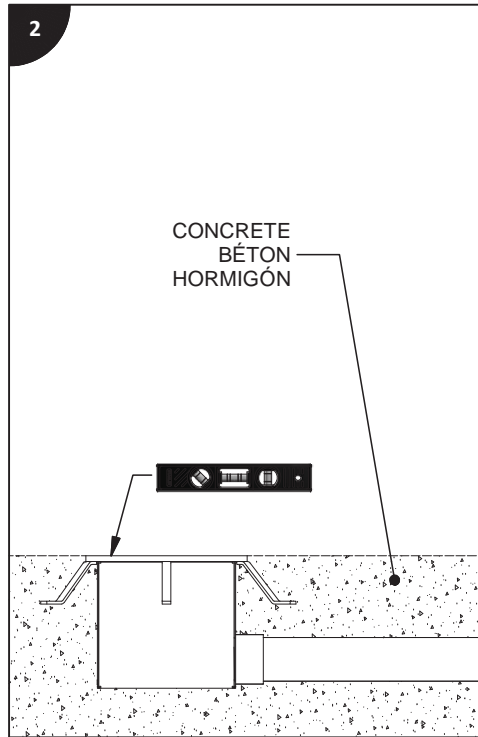
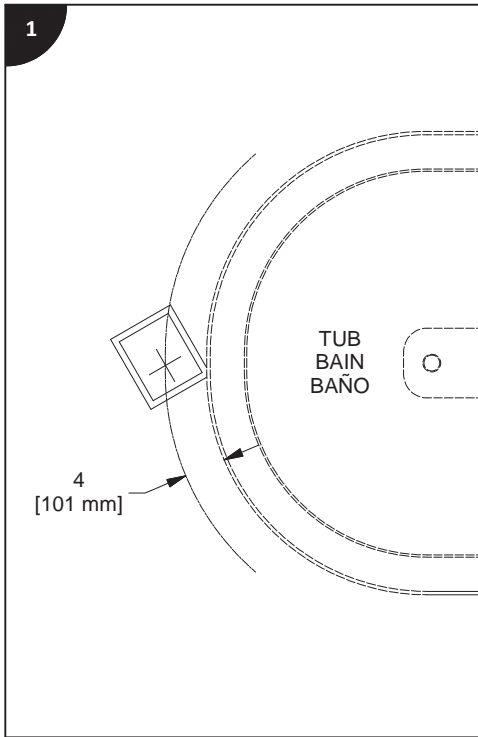

8

TUB - BAIN - BAÑO

* MAX 1/4
[5 mm]

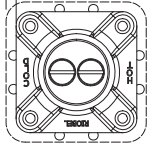

FINISHED FLOOR
PLANCHER FINI
PISO TERMINADO

DOES NOT EXCEED 1/4 [5mm]
* NE PAS EXCEDER 1/4 [5mm]
NO SUPEREN EL 1/4 [5mm]

9

TUB - BAIN - BAÑO

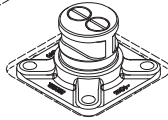

CHECK
VÉRIFIER
VERIFICAR

