

Lifestyle Guide

to Power Wheelchair Selection



Yes, you can.®



Choosing the most suitable power wheelchair for the user

FWD vs MWD vs RWD

- ▶ Occupations/tasks/activities are the very essence of life and being able to fully participate in these is what helps contribute to an individual's quality of life. Having **the right wheelchair** is, therefore, essential to support participation of individuals with reduced mobility in activities that support and help enrich daily life.

Everyone is unique! To select the right wheelchair for an individual, the following should be considered:



Performance

This guide aims to discuss the various performance benefits and areas of consideration of **FWD**, **MWD**, and **RWD** power wheelchairs. Informed decision making can help provide a solution that will enable individuals to live their lifestyle.

While there can be countless criteria to consider, two very important things are:

- ▶ Where the client spends most of their time – indoors or outdoors
- ▶ What they do in their wheelchair while indoors or outdoors



The wheelbase layout

Front wheel drive (FWD)



Mid wheel drive (MWD)



Rear wheel drive (RWD)

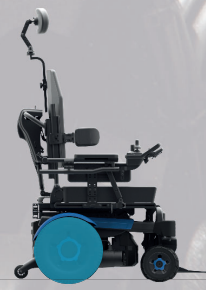

Indoors

Space considerations

Key constraints

The spatial layout of the indoor space where the client will spend most of their time is a key consideration as Power wheelchair bases vary in size.

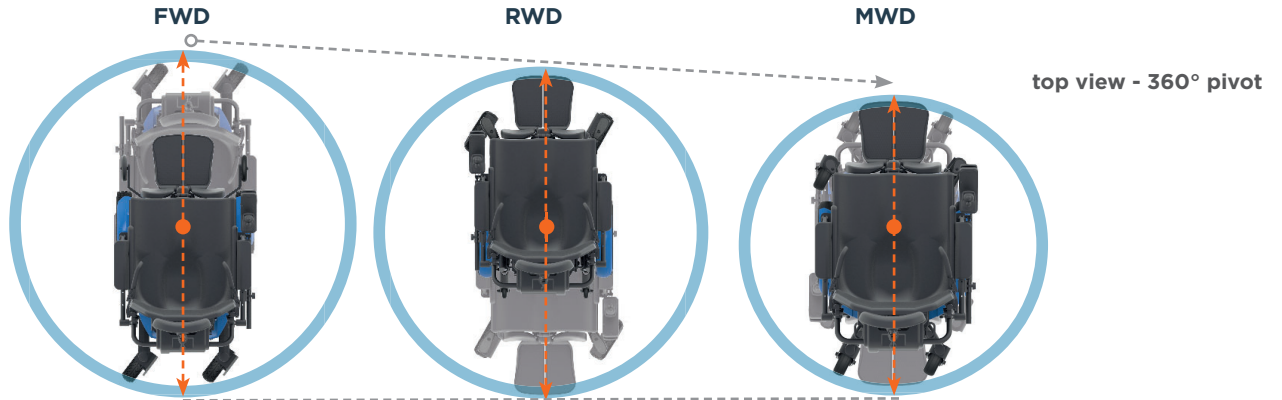

● **base turning diameter**

Things to consider in this assessment include dwelling entrance, hallway widths, room sizes, turning angles, doorways, floor surfaces, and other living spaces the client spends most of their time maneuvering through.

Indoor Environments	FWD	MWD	RWD
Narrow hallways	•	••	•
Small rooms	•	••	•
Elevators	•	••	•

Maneuverability and turning in tight spaces

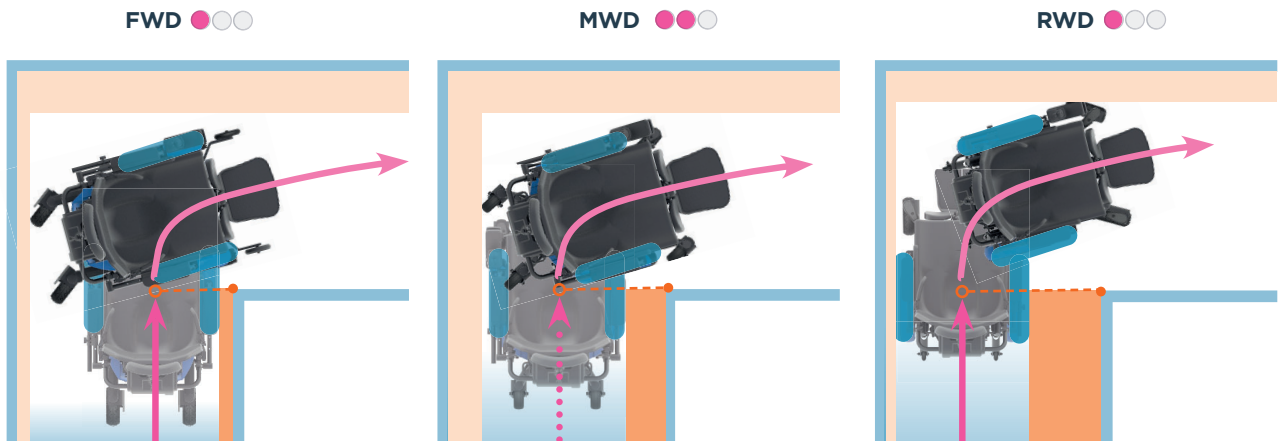

The **FWD** base has a bulkier rear end and requires more room behind it to make a turn.

The **MWD** requires the least amount of room to make a turn.

The **RWD's** bulk is in front of it so while it needs more room than the MWD, the client has more oversight during the turn than on the FWD

■ **proximity to wall**

○-○ **relationship between corner and center of the wheel base**

After considering indoor spatial needs which often tend to be small and tight, and typical indoor flooring, a general conclusion can be drawn that the base that best optimizes indoor driving is the **mid wheel drive**.

System Functions ▼

Function	FWD	MWD	RWD
Tilt/Recline/Elevate	•	••	•
Driving Elevated	•	••	•
Reach Forward	•	••	•
Standing	•	••	N/A

Note: Both Front and mid wheel bases can support ALL functions; however the mid wheel drive is better because all four casters can be locked to help increase stability.



Outdoors

General considerations

Outdoor factors

When a person is active outdoors then other factors need to be taken into consideration such as:

- ▶ Drive Intuition
- ▶ Unpredictable terrain
 - Navigating curbs/large thresholds
 - Maneuvering on slopes
 - Tracking on side slopes
- ▶ Going longer distances at faster speeds
- ▶ Sports

Let's explore some key factors to consider that help navigate a selection for the outdoor lifestyle. One thing to keep in mind is if the user is in a power wheelchair and is comfortable with the drive wheel location it might be better to keep them with the same drive wheel location (FWD, MWD, or RWD).

Driver intuition

The further the driver's head is from the center of the axis of rotation, the quicker the individual will perceive they are moving when turning, making it less intuitive to control. The closer the driver's head is to the axis of rotation of the chair when turning, the slower the individual will perceive they're moving. Turning with a **mid wheel**

drive creates the most intuitive handling and controlled feeling for the user. Making a turn in a **front wheel drive** brings the head away from the axis of rotation, therefore, making it the most difficult to drive and control.

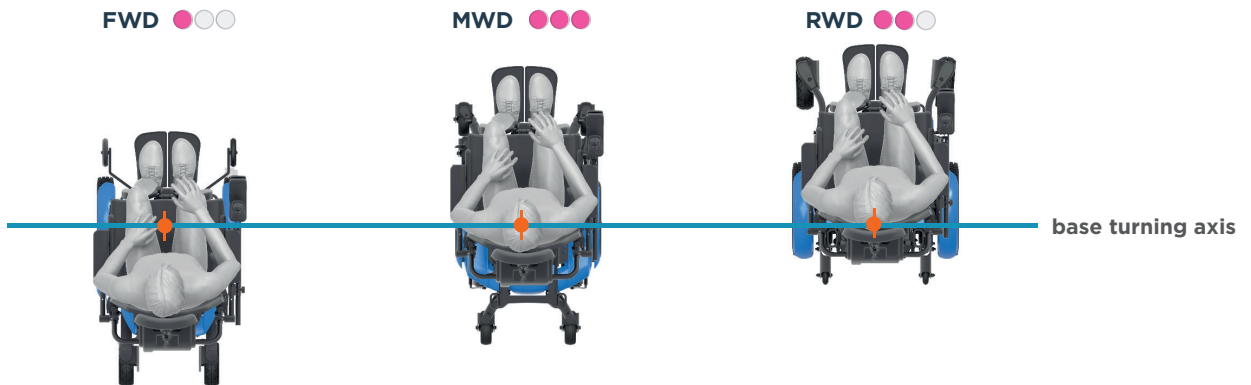

Unpredictable terrain

Navigating curbs/large threshold

Rear wheel drive navigates such terrain well because the large front caster encounters the curb first.



Maneuvering on slopes

FWD ●○○



A **front wheel drive** can make slope transitions with ease, but needs the front anti-tipper to help prevent tipping forward when descending a slope. These anti-tippers need to be raised high enough to prevent the drive wheels being lifted during the transition.

Note: In general, it is important to adjust the footplate height just enough to prevent hitting the surface of the incline during transition. Power tilt users may benefit from using slight tilt when driving down hills or declines, to improve ground clearance of the footplates and enhance postural stability.

MWD ●●○



A **mid wheel drive** has fixed front arms that can cause the drive wheels to lift off the ground and lose traction when transitioning off a slope.

RWD ●●●



The front castors of a **rear wheel drive** transitions on slopes with ease. Anti-tippers prevent the chair tipping backwards on inclines and the weight distribution over the rear wheels and forward placed casters help prevent the chair tipping forward on descending a slope.

Tracking on side slopes

Gravity will have an impact on a powerchair while driving on a slope. Depending on the axis of rotation and where the most weight is distributed, the chair will veer downwards with the castors.

FWD ●○○



On a slope, the weight in a **front wheel drive** chair is at the back causing the rear castors to veer off in the downward direction of the slope. Veering is not so easily corrected, like it is with the rear wheel drive bases, especially at higher speeds.

MWD ●●●



Mid wheel drive provides little to no veering, as the weight is equally distributed between the front and back castors.

RWD ●●○



Weight on the **rear wheel drive** is in the front causing front castors to veer off downwards in the direction of the slope. This veering is easily corrected because the powered rear wheels push the chair forwards, helping to correct deviation of direction of the front castors.

Note: Some chairs offer tracking technology designed to keep the chair on its intended path.

Outdoors

General considerations ▼

Longer distances at faster speeds

When a user spends time outside driving, they want to get there fast and some chairs are easier to drive at higher speeds and require less input when traversing long distances thus reducing fatigue. A **rear wheel drive** base gives the best control when driving at speed and long distances because the steering happens at the back

of the powerchair and not every small deviation is immediately translated in a change of course or direction. The opposite and least controllable wheelchair is the **front wheel drive**. The **mid wheel drive** will provide an average control of the powerchair.

FWD ●○○

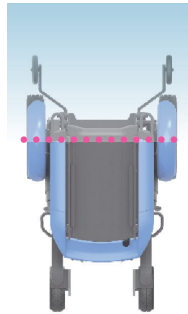

MWD ●●○



RWD ●●●



Sports

Wheelchair users who participate in sports should consider the **rear wheel drive** because the bulk of the chair is in front of them giving

them better visibility, and because the chair does not immediately change course or direction with every small deviation

Outdoor performance overview

Considerations	FWD	MWD	RWD
Driving intuitiveness	●	●●●	●●
Stability and ability to handle unpredictable terrain ▼			
Obstacle handling (ascending)	●●●	●	●●
Slope transitions handling (descending)	●	●●●	●●
Tracking on side slopes	●	●●●	●●
Uneven terrain	●●	●	●●●
Getting to your destination quickly	●	●●	●●●
Going the longer distance (college campuses, airports, long commutes)	●	●●	●●●

After considering outdoor needs which often tend to be wide open, contain obstacles and slopes, a general conclusion can be drawn that the base that best optimizes outdoor driving is the **rear wheel drive** followed by the **mid wheel drive**.



FWD vs MW

Choosing the most suitable primary consideration

RWD



OR

MW

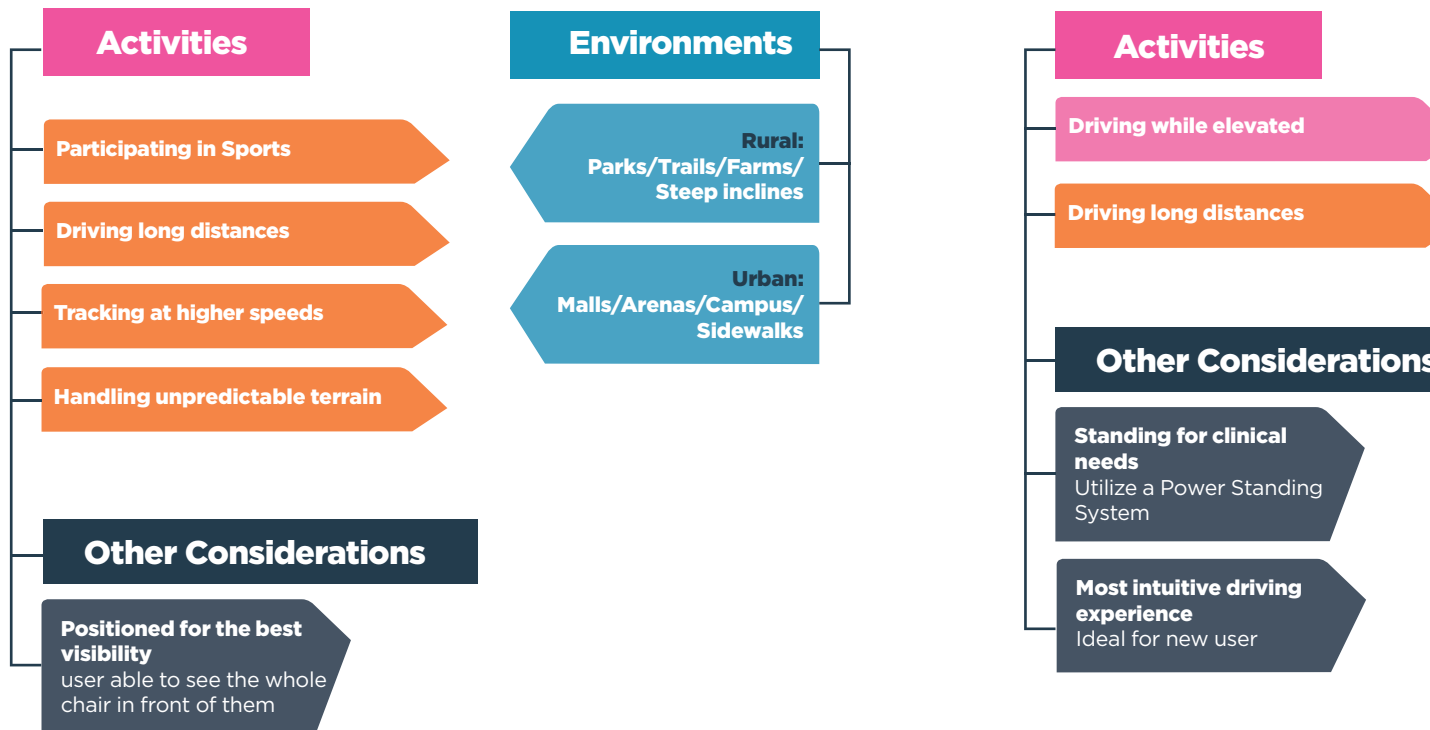

■ Indoor activity
■ outdoor activity

RWD vs RWD

Power wheelchair based on conditions for the user

RWD



FWD

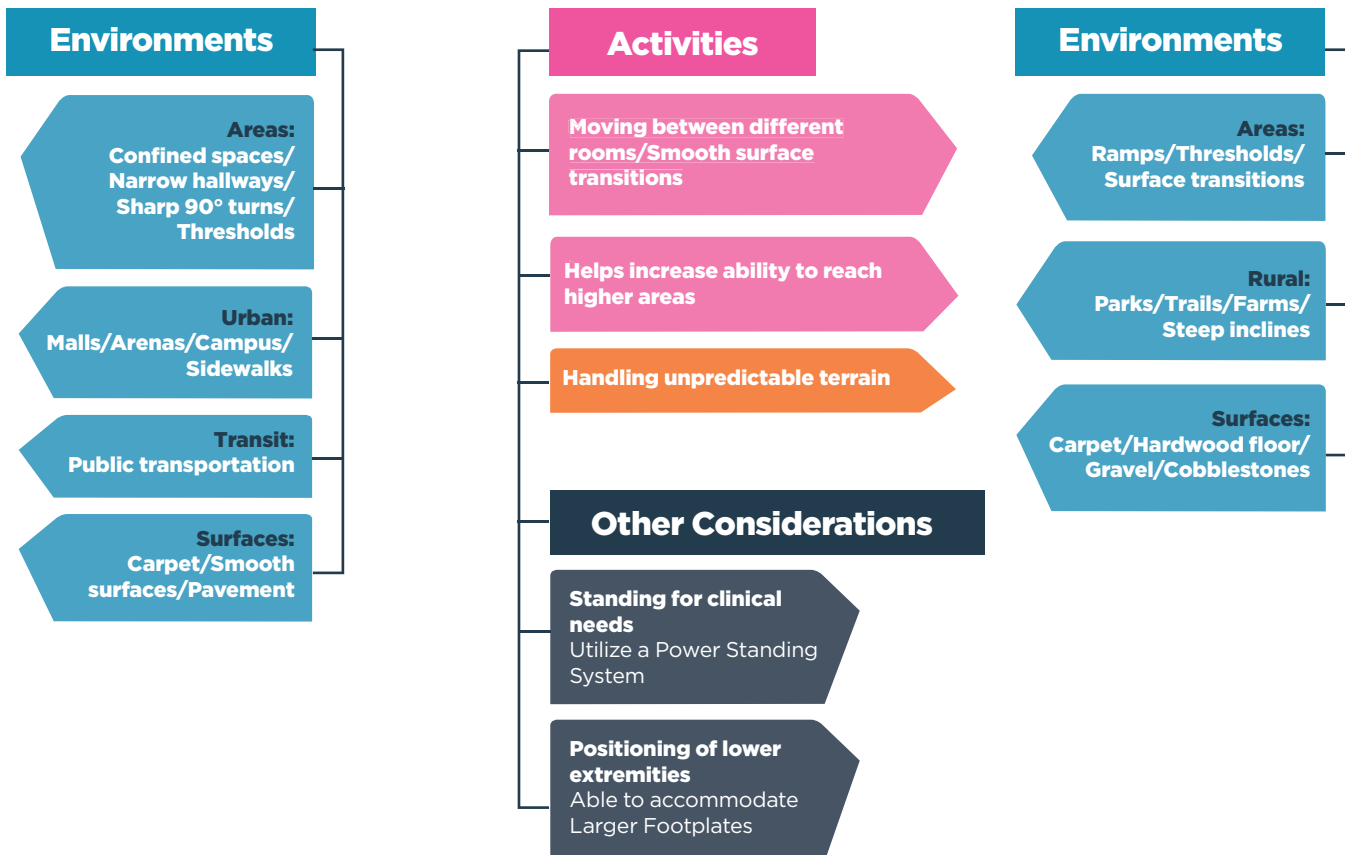

This document is intended exclusively for licensed healthcare professionals. The information provided in this document is intended only to be general in nature, does not represent or constitute medical advice, and is not intended to influence or replace a healthcare provider's independent assessment and care of any patient, based on a patient's individual context and health status. Each patient should be examined and advised individually by a licensed healthcare professional. For product use and operation always consult and follow all applicable user manuals, safety information, product inserts, and instructions for use.



Invacare Corporation
www.invacare.com

USA

One Invacare Way
Elyria, Ohio
44035-4190
(800) 333-6900

Canada

570 Matheson Blvd. E.,
Unit 8
Mississauga, Ontario
L4Z 4G4 Canada
(800) 668-5324

Motion Concepts

www.motionconcepts.com

USA

700 Ensminger Rd. Suite 112
Tonawanda, NY 14150
(888) 433-6818
Fax: (888) 433-6834

Canada

84 Citation Dr., Unit 1-7
Concord, ON L4K 3C1
(866) 748-7943
(905) 695-0134
Fax: (905) 695-0138

©2021

Invacare Corporation.
All rights reserved.
Trademarks are identified
by the symbols ™ and ®. All trademarks are
owned by or licensed
to Invacare Corporation
unless otherwise noted.
Specifications are subject to
change without notification.
Form No. 21-090 210435