

PG300W

Octagonal Sand Box

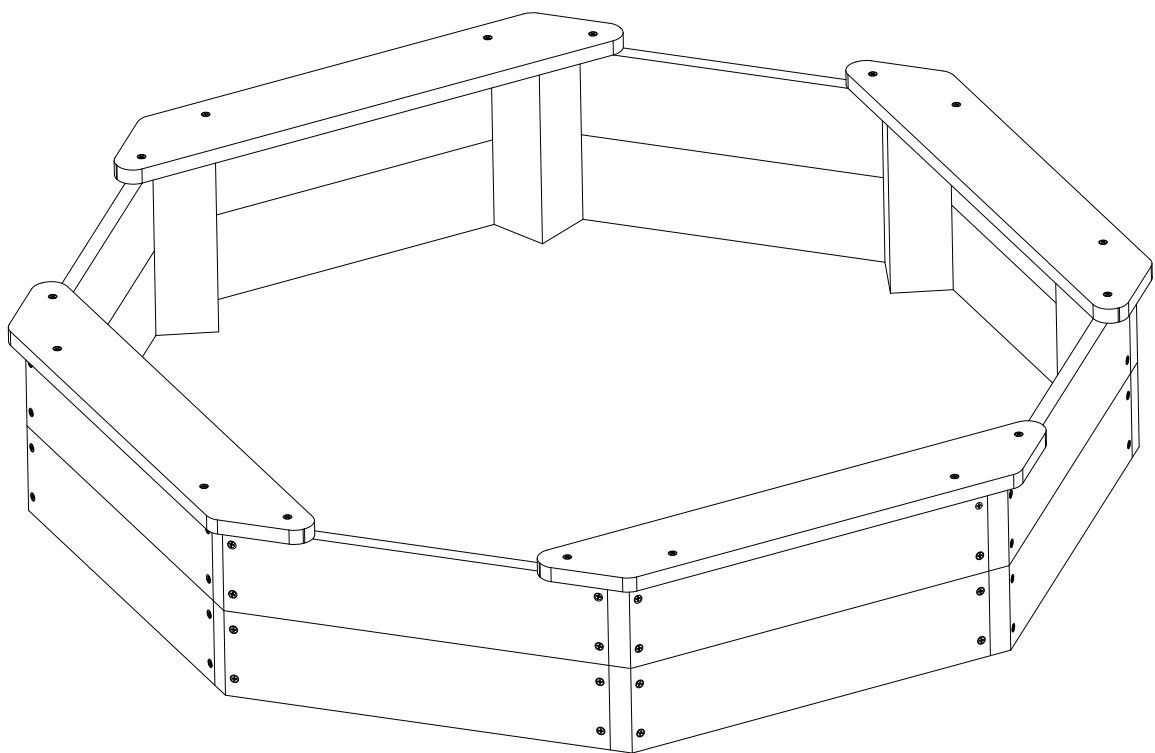

ASSEMBLY INSTRUCTIONS

for children 18+ Months

**Assembly requires 1 adult
(approx. 30 minutes assembly time)**

FOR FAMILY OUTDOOR DOMESTIC USE ONLY

Warning: not suitable for children under
36 months until fully assembled due to small parts

Advisory Section

To ensure the safety of you, the installer and your children, it is important that these instructions are read fully before commencing the positioning and installation of this product.

Keep your sandbox safe for the children

1. Always cover the sandbox when not in use, to prevent unwanted animals from playing in the sand.
2. Before covering your sandbox, place a large object in the center of the sand to prop up the cover. This will allow water to drain off the cover, and prevent any rain water from "pooling" in the center of the sand box. This must be checked regularly.
3. Should any water still accumulate and form a pool, please ensure that this water is removed. Standing water can pose a danger to children.
4. Regularly check sand for impurities and any other sharp objects that may cause harm to children.
5. Use washed playsand suitable for use in children's sand boxes.

Timber Advice

This product has been made from premium timber. Great care has been taken in selecting, treating and machining the timber before it is presented to you. Timber is a natural product and as such may experience changes throughout the course of its life. This means it may:

- Develop openings (gaps, slits, apertures, cracks, splits) along the line of the grain. These openings are due to the difference in moisture content between the internal and outer surfaces of the timber. This is to be expected, is totally acceptable and will not affect the integral strength, life or guarantee of the product.
- Warp and distort its shape. Any distortion will be slight and will not affect the safety or enjoyment of this product.
- Fade as the timber reacts with sunlight. The timber should be treated with a proprietary product to act as a protective barrier, i.e. a water repellent, on an annual basis.
- After first year of service treat product with a good quality treatment safe for children's use.

Routine Maintenance

It is advised that on a regular basis (i.e. at the beginning of the season and monthly thereafter) all main parts/ fixings are checked as secure, well oiled (if metallic), have no sharp points/edges and are intact. Replace, oil and/or tighten when necessary. Failure to do so may result in an injury or hazard.

Remember to keep these instructions in a safe place for future reference.

PARTS LIST

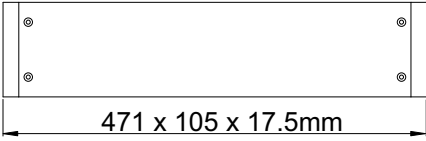
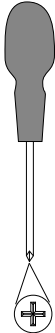
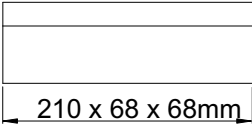
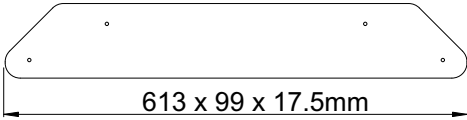
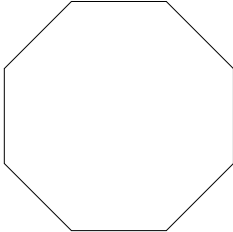
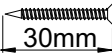
PART ID	DIMENSIONS WITH GRAPHIC	QUANTITY	TOOLS REQUIRED:
D1070	 <p>471 x 105 x 17.5mm</p>	x16	TOOLS REQUIRED: 
D1071	 <p>210 x 68 x 68mm</p>	x8	
D1072	 <p>613 x 99 x 17.5mm</p>	x4	
D1074		x1	
M5 x 30	 <p>30mm</p>	x80	

1

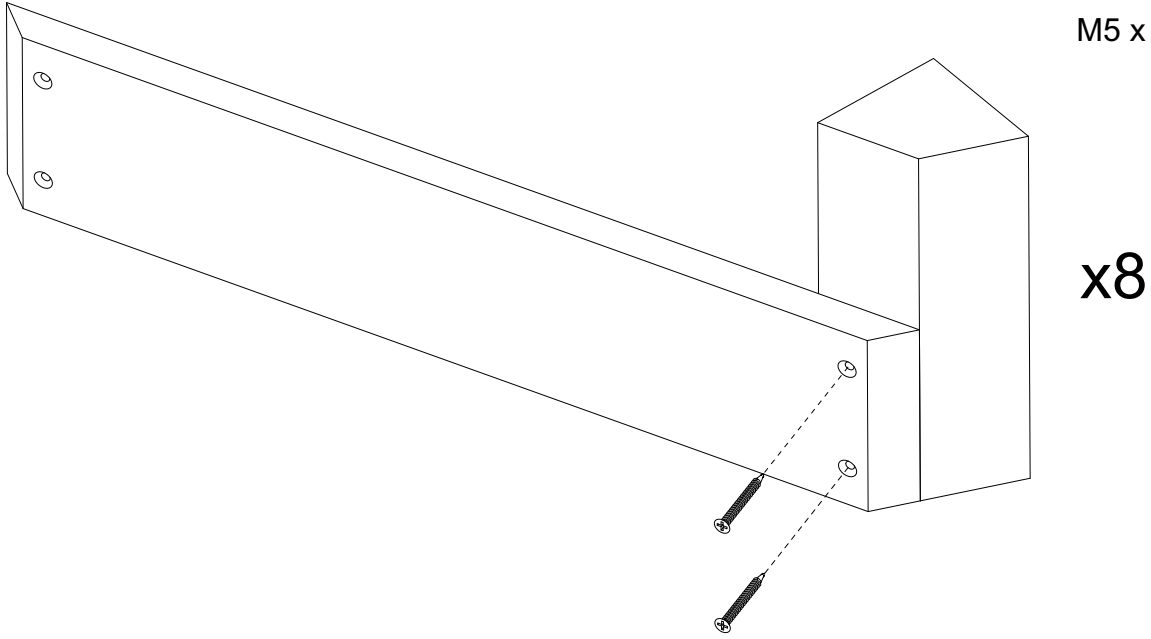
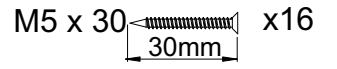
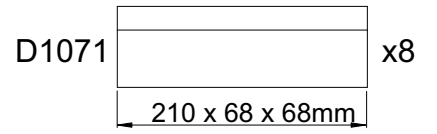
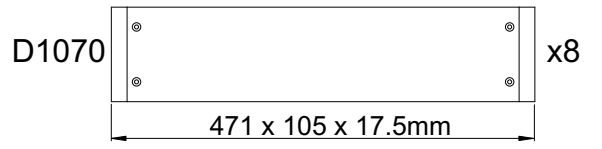

2

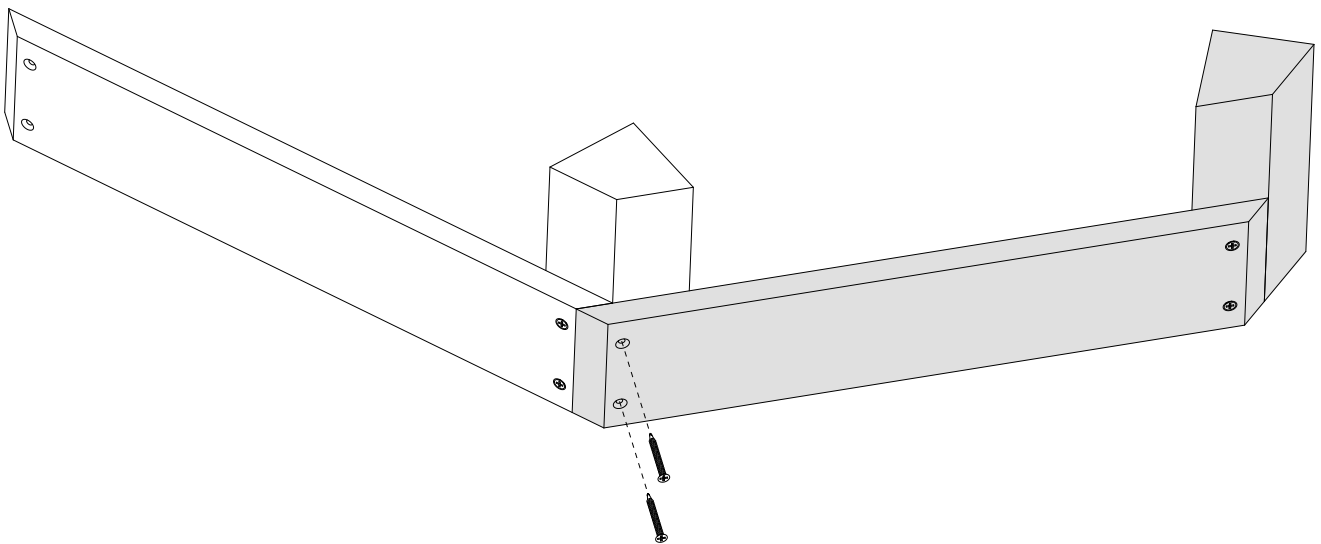
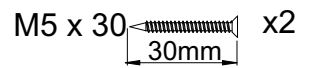
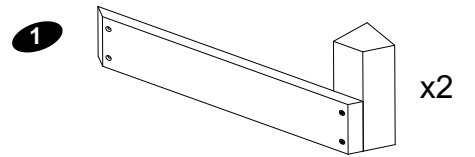

3

1

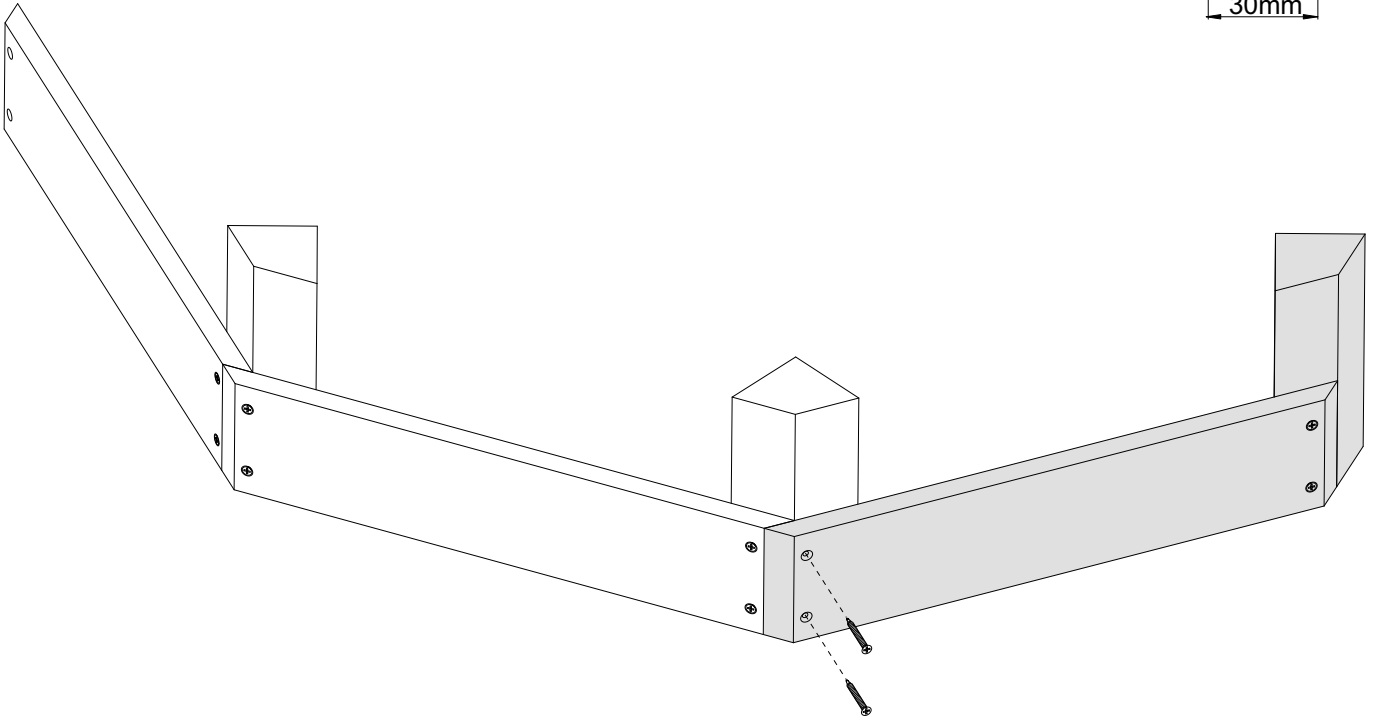
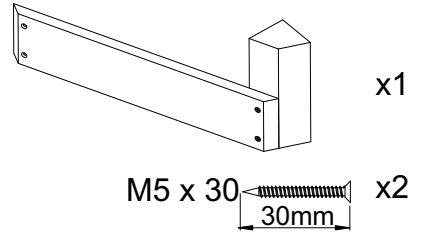

4

1

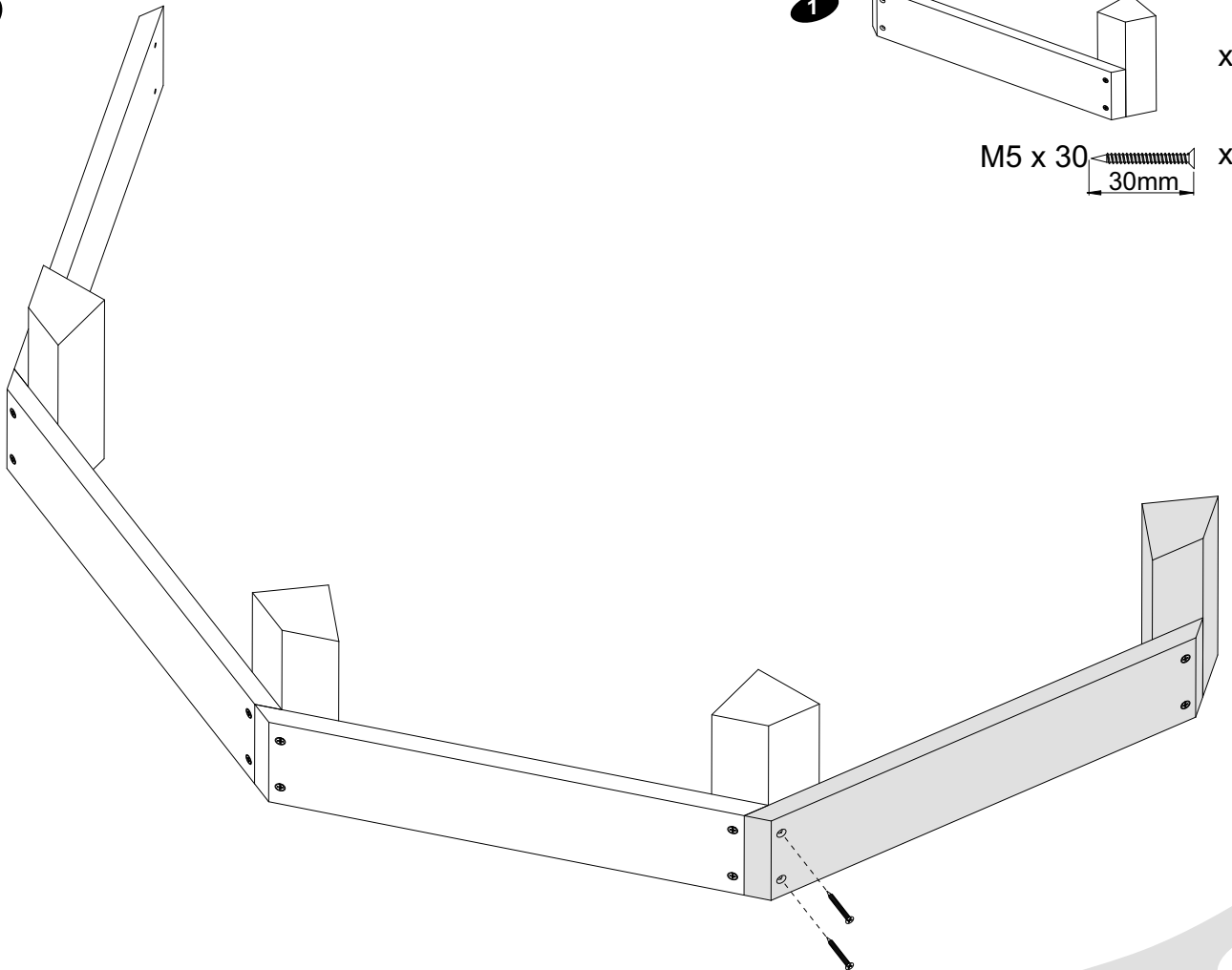
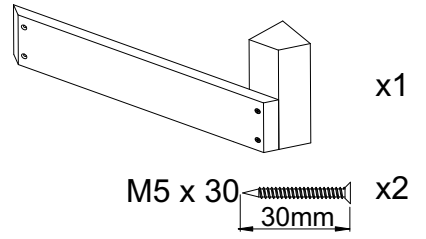

5

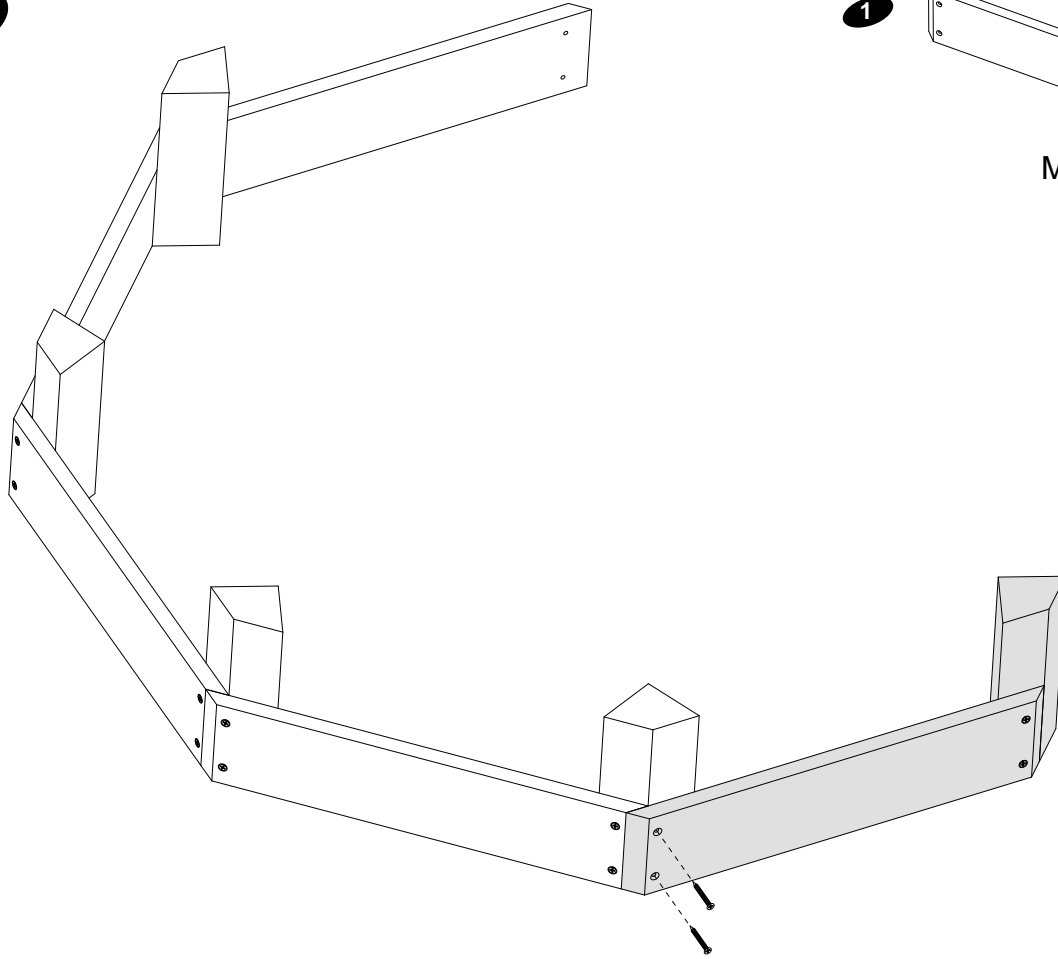

1

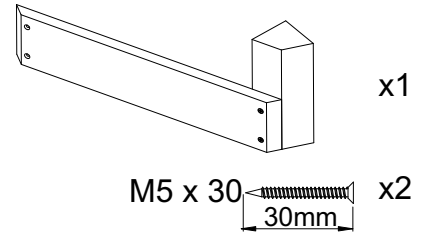

6

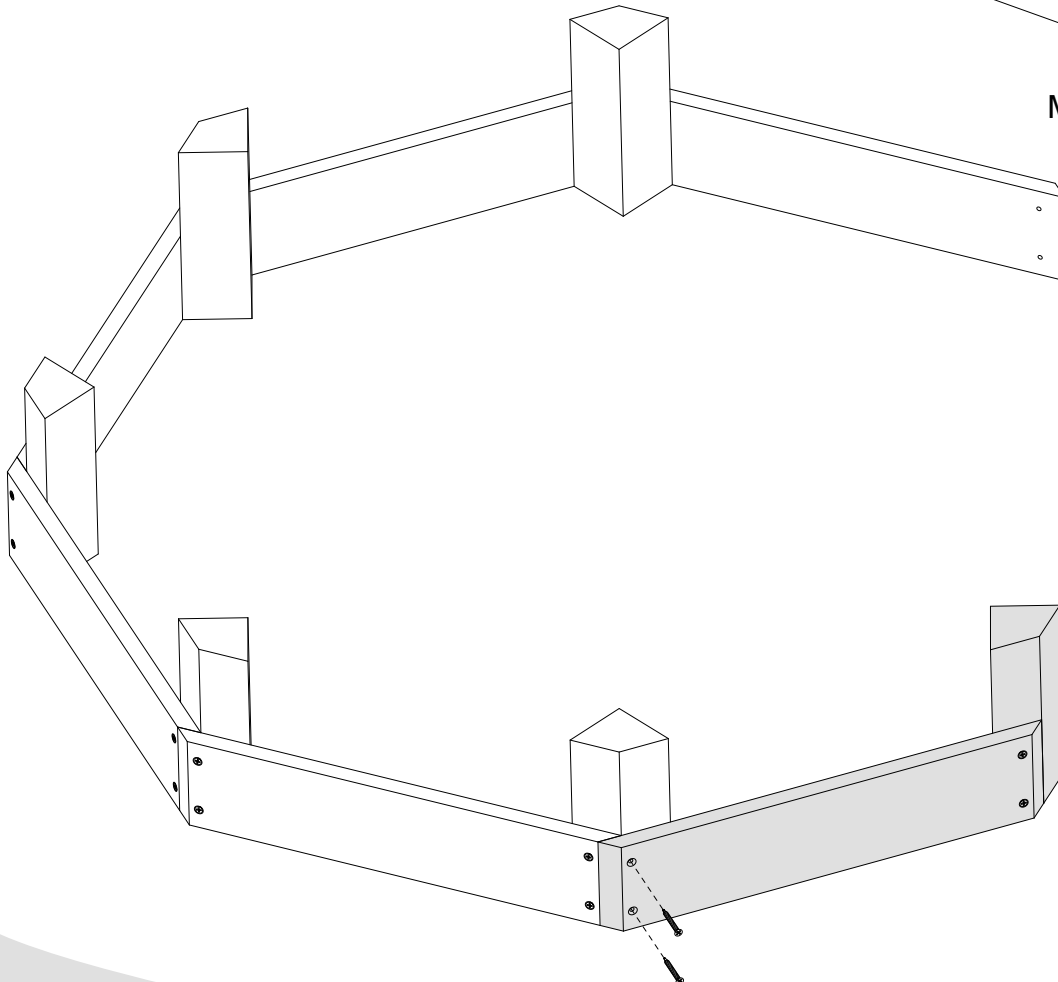

1

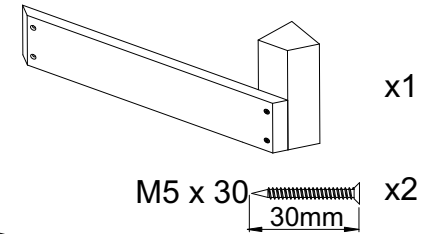

7

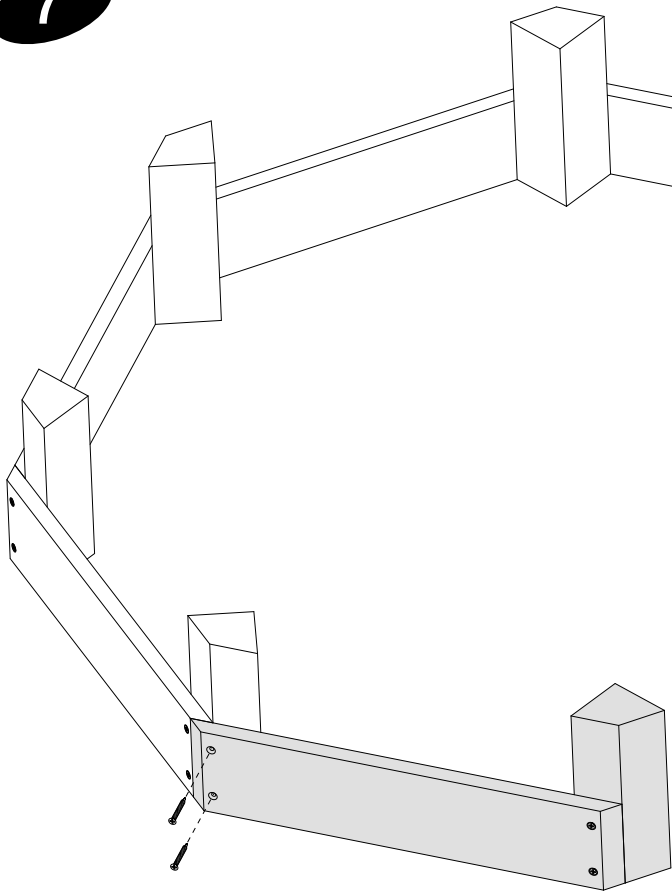

1

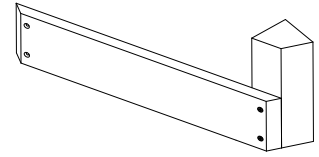

x1

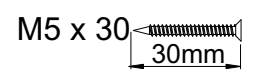

x2

8

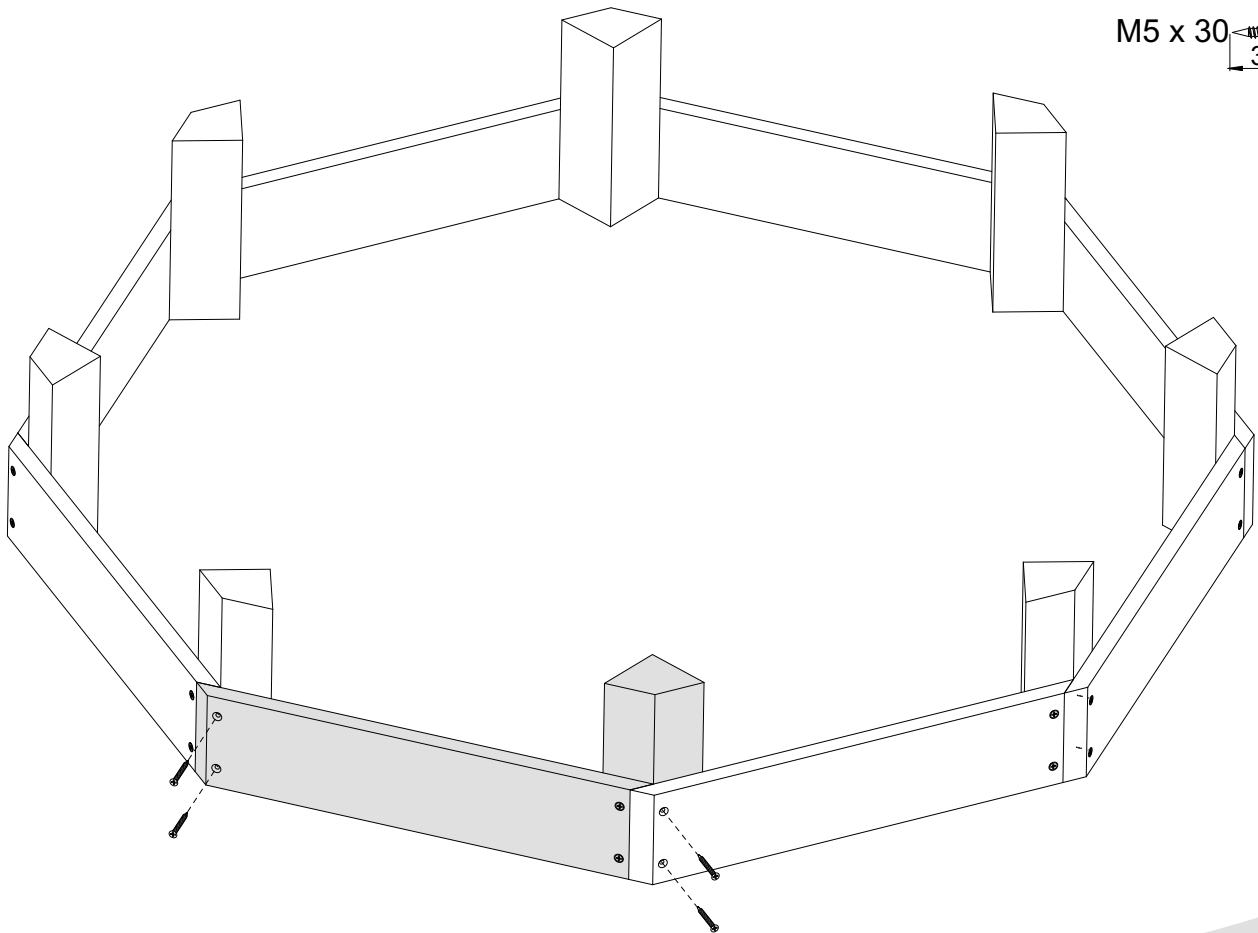

1

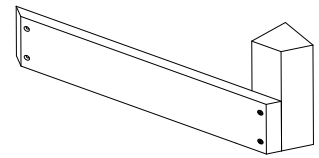

x1

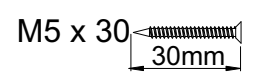

x4

9

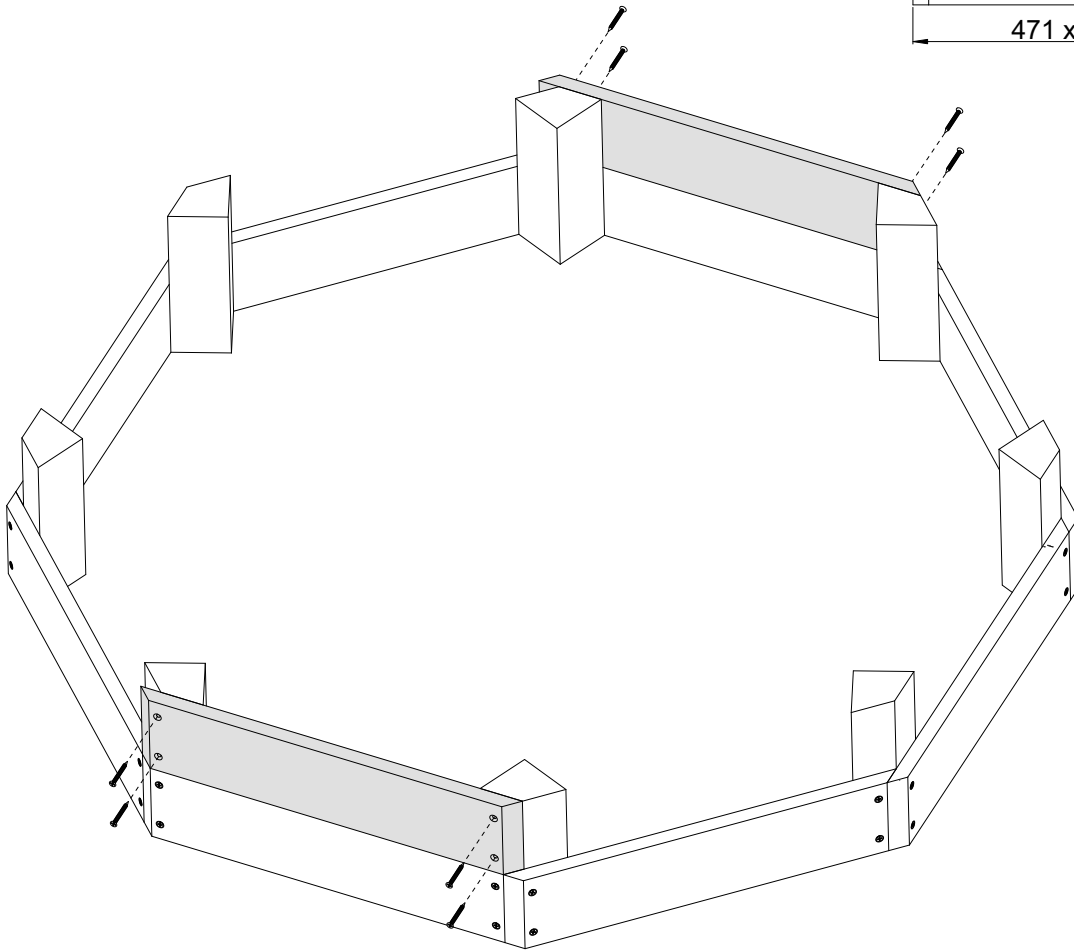
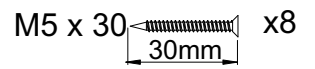
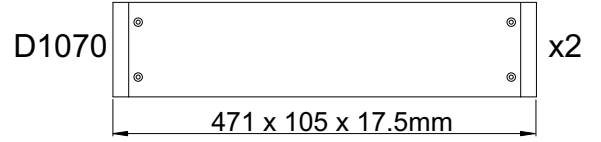

10

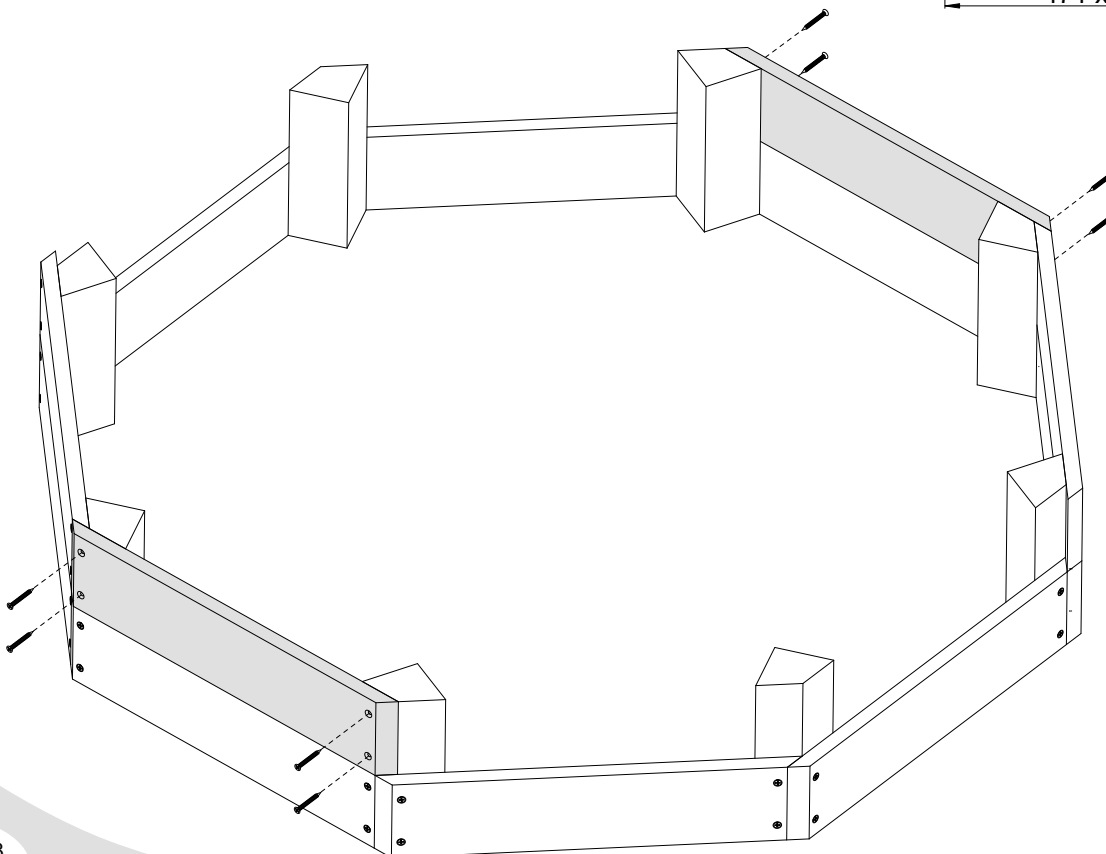
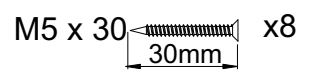
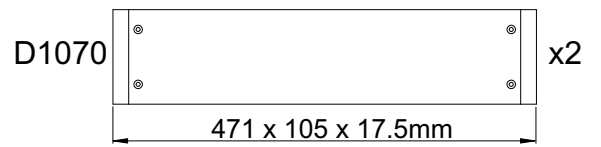

11

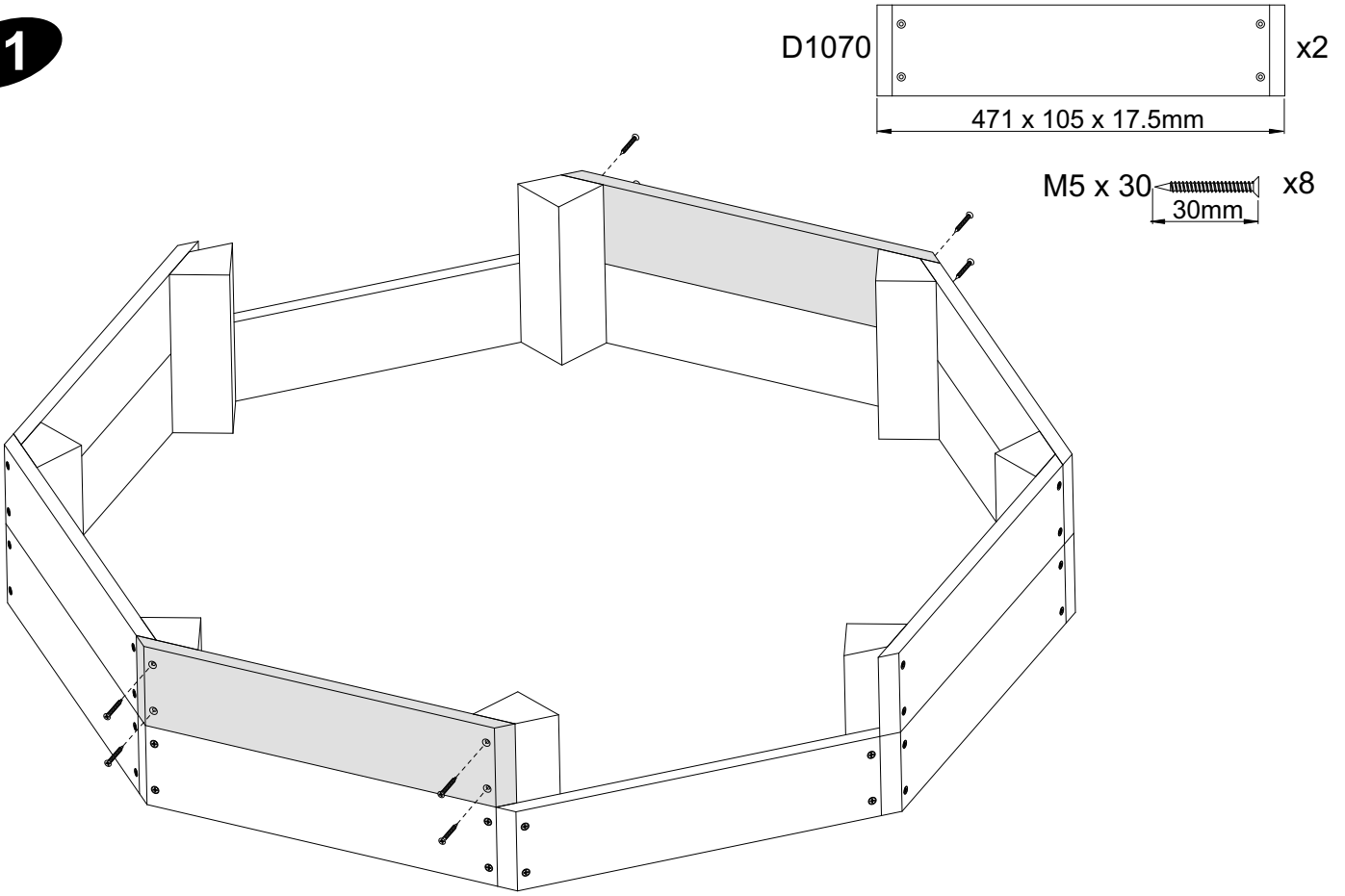

12

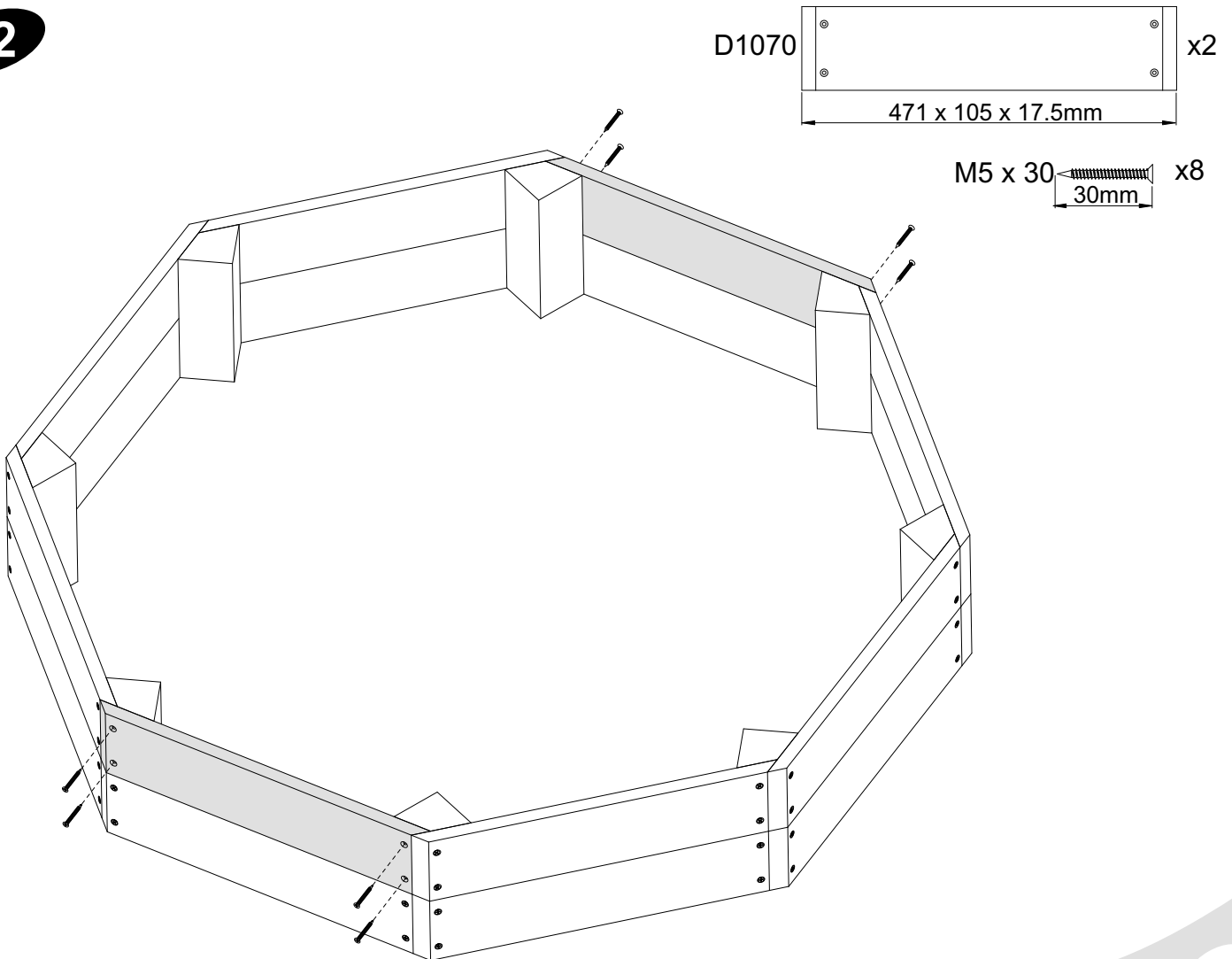

D1072 x4
613 x 99 x 17.5mm
M5 x 30 x16
30mm

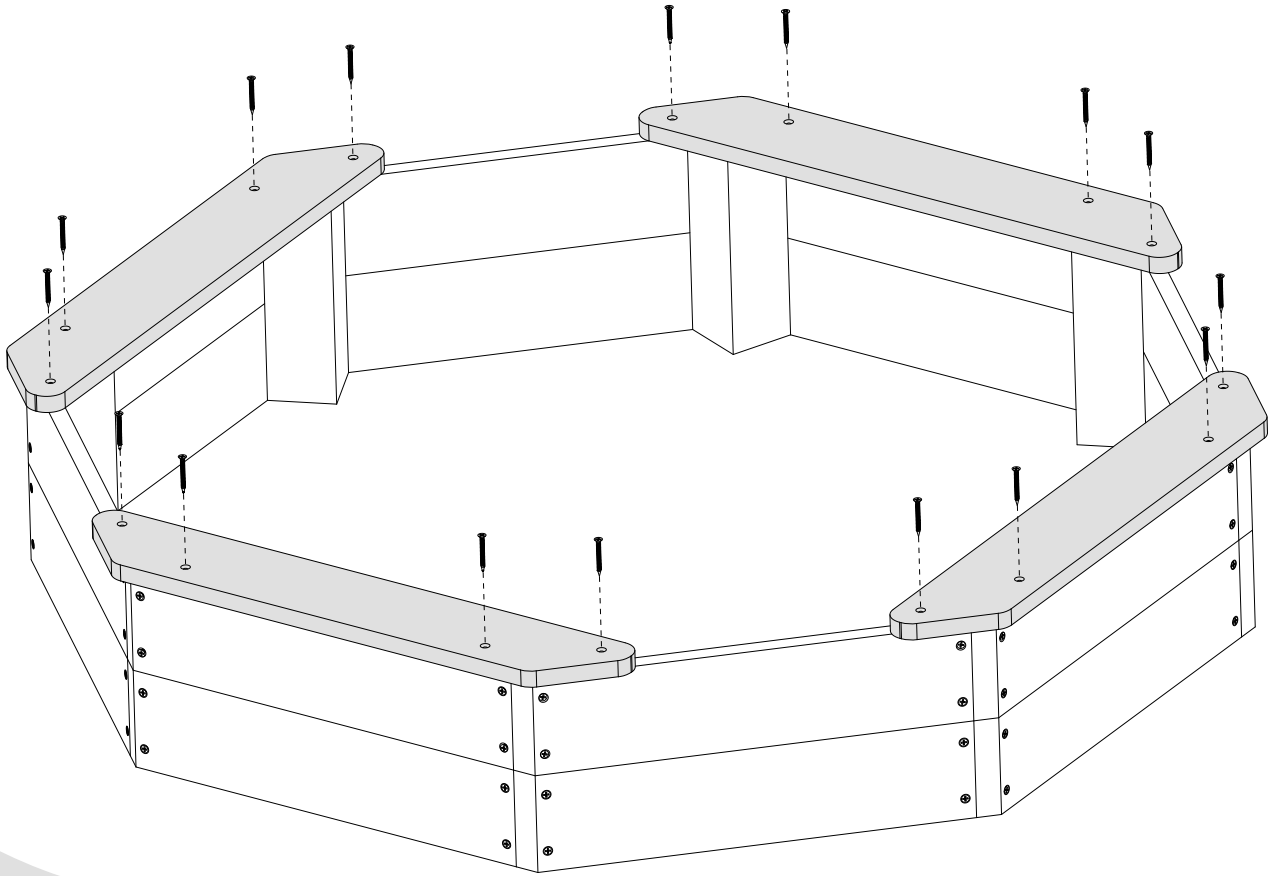
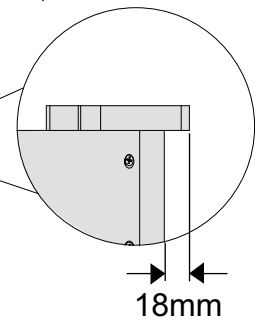
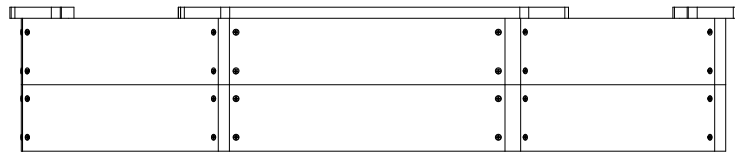
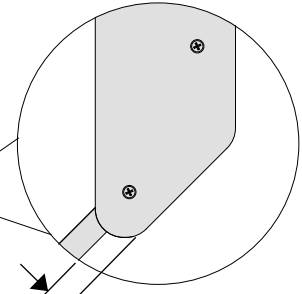
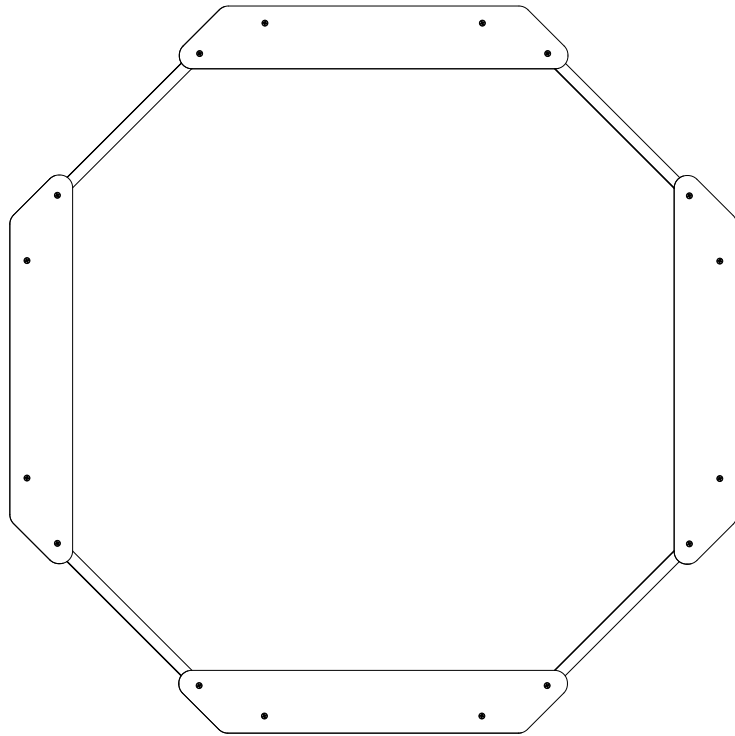

14

