

# WINGITS®

WHERE EXCELLENCE COMES STANDARD

HOSPITALITY CATALOG 2022



THE #1 PROVIDER  
OF BATHROOM  
ACCESSORIES TO  
HOSPITALITY

SUPERIOR QUALITY  
BACKED BY  
A LIFETIME WARRANTY

ENDLESS COMBINATIONS  
OF STRENGTH & BEAUTY



For over 20 years, Winglts® has expertly designed and manufactured bathroom accessories, room solutions, patented fastening systems, and custom products for commercial markets throughout North America.

As the #1 specified brand in hospitality and leader in innovative design, we deliver masterfully engineered, superior value solutions in a myriad of styles. By utilizing proprietary manufacturing processes, our products guarantee revolutionary strength, quick and easy installation, and lifetime durability.

Global vendor partnerships, exceptional customer service, and our commitment to sustainability secures our industry leadership.



# WINGITS®

## 3X

THE SPECIFICATIONS  
IN HOSPITALITY  
THAN ALL  
OUR COMPETITORS  
**COMBINED**

Your properties deserve Winglts® –the most trusted solution for bathroom accessories across all major hospitality brands.

For over two decades, 1.93 billion hotel guests in 2.5 million rooms across North America have enjoyed the strength and beauty of Winglts® solutions.

For every property, from economy to luxury, Winglts® solutions span all lifestyles delivering the best value and return on investment.



NO MATTER WHAT  
YOUR PROJECT NEEDS,  
YOU'LL FIND THE  
PERFECT SOLUTION  
WITH WINGITS®

**1.93**  
BILLION  
Guest Experiences



**2.5**  
MILLION  
Rooms in North America



## INSTALLED IN MINUTES...

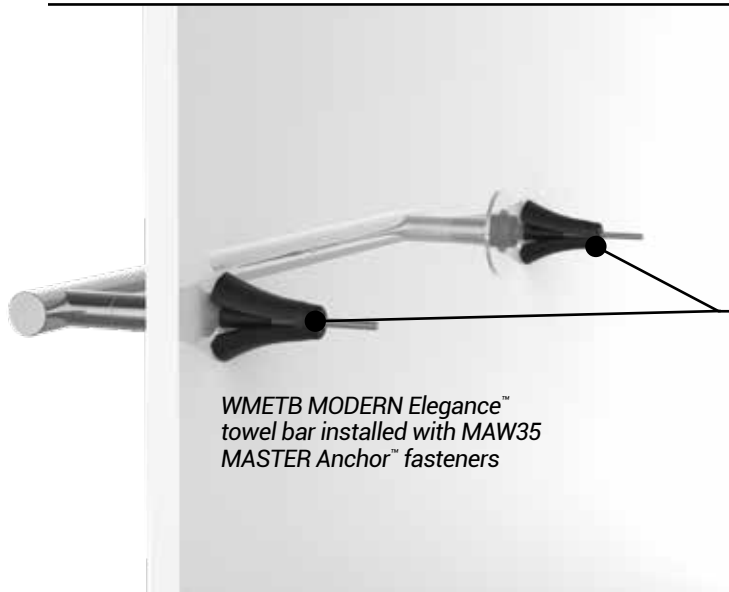

### WORLD'S STRONGEST FASTENER®

Winglts® patented fastening system allows for quick & easy installation, adds revolutionary strength, and is guaranteed to never loosen or sag.

WMETB MODERN Elegance™ towel bar installed with MAW35 MASTER Anchor™ fasteners

### BRIDGEBIND™ TECHNOLOGY

Patented BridgeBind™ technology eliminates joints, creating the ultimate form in structural integrity.

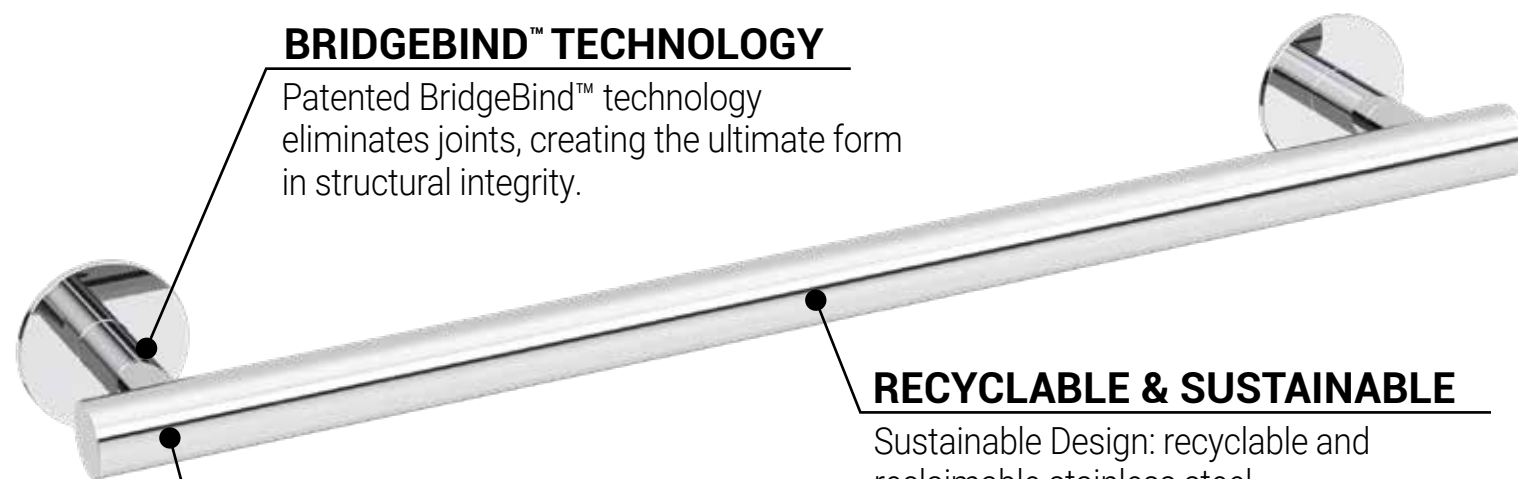

### RECYCLABLE & SUSTAINABLE

Sustainable Design: recyclable and reclaimable stainless steel.

### 18/8 (304) STAINLESS STEEL

Forged with commercial grade 18/8 (304) stainless steel, providing ultimate strength and durability.

...GUARANTEED FOR A LIFETIME

## ENDLESS COMBINATIONS OF STRENGTH & BEAUTY

### ENDLESS OPTIONS

20 designer collections available with 12 standard finishes, 1,625 custom RAL colors using polyester fibrous paint, and unlimited modular designs.

### UNRIVALED QUALITY

Each collection is forged from commercial-grade stainless steel and is sustainably designed.

### TRI-LINEAR BUFF TECHNOLOGY™

Delivers the beauty of polished chrome paired with the strength of stainless steel.

### WORLD'S STRONGEST FASTENER®

Installs quickly and guaranteed to never loosen.



### STANDARD FINISHES



POLISHED STAINLESS STEEL



SATIN STAINLESS STEEL



BLACK (matte, black ORB, or satin)



WHITE



BISCUIT

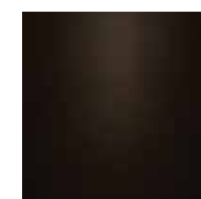

OIL RUBBED BRONZE

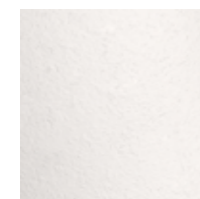

SURE GRIP WHITE



POLISHED BRASS



BRUSHED BRASS



ANTIQUÉ BRONZE

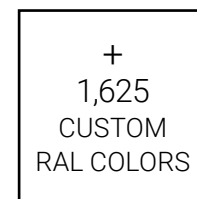

+  
1,625  
CUSTOM  
RAL COLORS

# WINGITS® CAST MARBLE SOLUTIONS

As a leader in room and bath solutions, Winglts® is a top provider of innovations to the commercial market since 1999.

Our newest product line, Winglts Wallz™, is a full suite of Cast Marble products to complete any shower/bath space.

## AUTOMATIC OVERAGES

Panels come with an automatic 2% product overage to help keep projects on track.

## SUPERIOR LEAD TIMES

Thanks to our centrally located Texas warehouse, we can ship anywhere in the US quickly and efficiently.

## NON-POROUS

Cast Marble resists the growth of mold and mildew and is easy to clean with minimal maintenance.

## WHITE GLOVE LOGISTICS

Specialized shipping and packing methods greatly decrease chances of breakage during transit.

## EXPERT CUSTOMER SERVICE

Our customer service team is standing by to assist at every step.

## COMMERCIAL-GRADE

Thanks to our superior DuraShield™ Gelcoat, our Cast Marble products are true commercial-grade.

## HYGIENIC

Cast Marble is easily cleaned with common commercial cleaners, no specialized cleaners required.

## CLASS A FIRE RATED

We offer Class A fire rating as an option, to meet code.

## WARRANTY

Winglts® is proud to offer a 2 year warranty for our Cast Marble products.

## COMPLETE BATH SOLUTION

Only Winglts® offers solutions both in and out of the bathroom, along with custom product capabilities to create a truly one-of-a-kind aesthetic.

GET THE ENTIRE CAST MARBLE CATALOG:  
[SALES@WINGITS.COM](mailto:SALES@WINGITS.COM)

# WHY WINGITS® CAST MARBLE?

WINGITS WALLZ™ CAST MARBLE		COMPETITORS
DURASHIELD™ GELCOAT	✓ Top performing Gelcoat, unmatched on the market	✗ Standard Gelcoat
AUTOMATIC OVERAGES	✓ 2% overage on every order	✗ Not every company offers overages
SUPERIOR LEAD TIMES	✓ USA centrally located warehouse	✗ Shipping times can be much longer
A-FRAME PACKING	✓ Minimal breakage during transit	✗ Breakage during transit is common
EXPERT CUSTOMER SERVICE	✓ Here to assist from start to finish	✓ Typically standard
NON-POROUS	✓ Resists mold and mildew	✓ Typically standard
COMPLETE BATH SOLUTION	✓ Full suite of products for every space	✗ Others may only offer panels and pans
COMMERCIAL-GRADE	✓ True commercial-grade product	✗ Not always commercial-grade
HYGIENIC	✓ Easily cleaned with common commercial cleaners	✗ Specialized cleaners sometimes required
CLASS A FIRE RATED	✓ Fire rated to meet code	✓ Industry standard
WARRANTY	✓ 2 year warranty	✗ Typically 1 year warranty



## REINFORCED A-FRAME PACKING

Materials are less likely to be damaged in transit.

Uniquely angled packing design prevents damage by stacking.

Offload and handle easily by simply tilting the panels out - minimizing potential damage to other panels.

GET THE ENTIRE CAST MARBLE CATALOG:  
[SALES@WINGITS.COM](mailto:SALES@WINGITS.COM)

# CAST MARBLE ACCESSORIES

A full suite of Cast Marble accessories are available to match your pan and panels and complete the shower/tub area.

Simple, sleek designs of our Cast Marble accessories add function and beauty.

All Cast Marble accessories feature a permanently sealed surface, resist the growth of mold and mildew, and require minimal maintenance.



Our Super Duty Fastener with Stainless Steel Insert (MMSOSS-SD) ensures structural integrity and longevity of the product.

*\*Not all Cast Marble accessories install using WingIts® fasteners, see product spec sheet for recommended installation.*



WWSH  
Shampoo/Soap Shelf



WWFL  
Straight Accessory Ledge

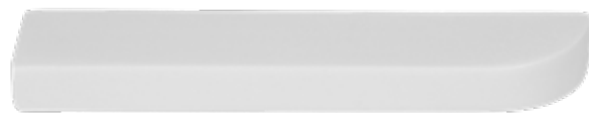

WWAAL  
Angled Accessory Ledge



WWFR  
Tapered Foot Rest

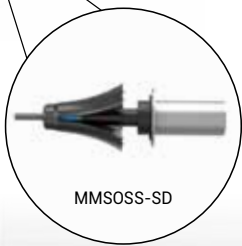

## DURASHIELD™ GELCOAT



All Cast Marble Accessories feature our unrivaled DuraShield™ Gelcoat is the heaviest in the industry.

DuraShield™ creates a structural, waterproof barrier to achieve the perfect finish.

# WINGITS® CAST MARBLE PATTERNS

## Panel Options

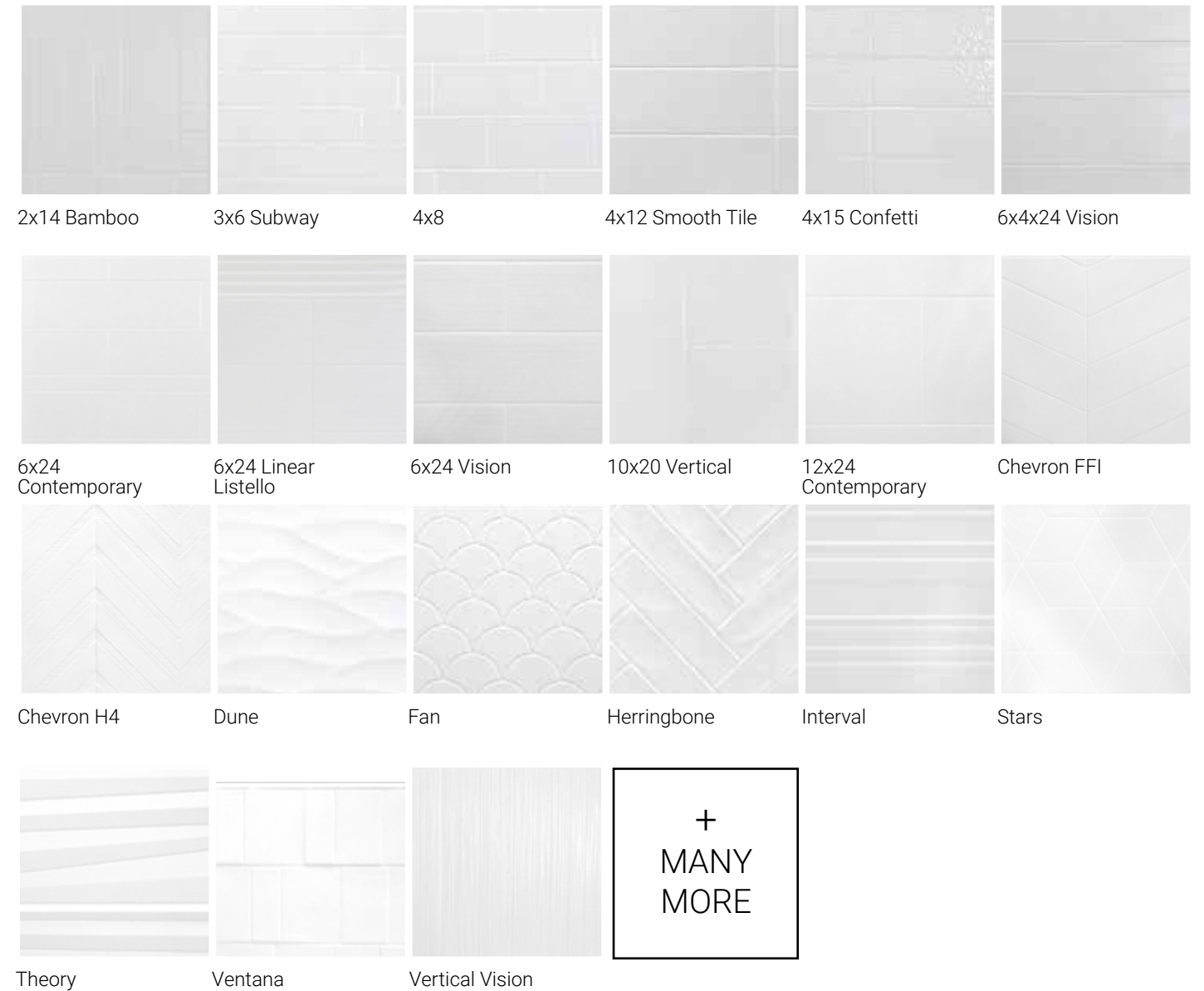

## Color Options (matte or glossy finishes available)

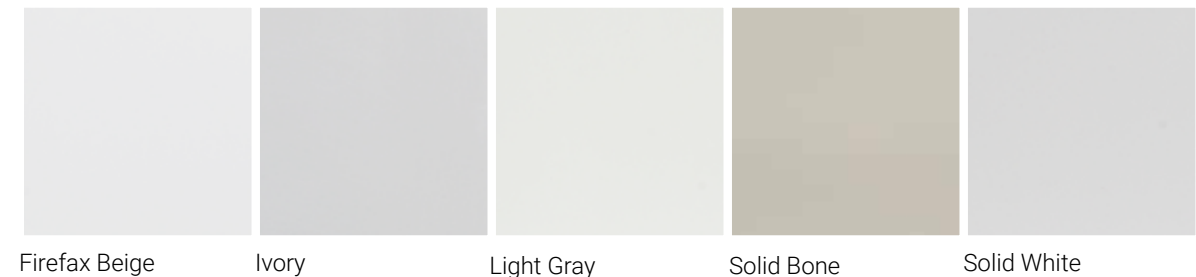

# WINGITS® LIGHTED MIRRORS

## SUPERIOR QUALITY IS THE STANDARD WITH WINGITS®

Our new Lighted Mirrors are UL Certified, Eco-Perfect™, and include seven standard features:

- Precise-View™
- Stainless Steel Safety Lock
- Winglts® Patented Fasteners
- PrintProof™
- SilverShield™
- Safety-Backed Glass
- High Efficacy



### WINGITS® LIGHTED MIRROR STANDARD FEATURES

### COMPETITORS

<b>PRECISE-VIEW™</b>	✔ CRI 85+, diffusers, superior quality LED driver	✘ Most features offered as upgrades
<b>DIFFUSERS INCLUDED</b>	✔ Included glass frosted diffusers and ambient acrylic diffusers	✘ Upgrade \$\$\$
<b>HIGH EFFICACY</b>	✔ 100+ Lumens per watt, super-efficient, uses minimal power	✔ Industry standard
<b>STAINLESS STEEL SAFETY LOCK</b>	✔ Ensures durability and unauthorized mirror removal	✘ Upgrade \$\$\$
<b>SAFETY-BACKED GLASS</b>	✔ Vinyl coating eliminates injuries and liabilities inherent in glass	✘ Sometimes standard
<b>SILVERSHIELD™</b>	✔ High-density silver backing to eliminate any distortion	✘ Upgrade \$\$\$
<b>PRINT-PROOF™</b>	✔ Fingerprint resistant finish	✔ Typically standard
<b>CCT 3000K-6500K</b>	✔ Choose what color temperature suits your need	✘ Upgrade \$\$\$ (temperatures over 3000K)
<b>10-YEAR LIMITED WARRANTY</b>	✔ 10-year limited warranty	✘ Typically 7-10 year limited warranty
<b>WATER-TITE™</b>	✔ Silica gasketing for a secure installation	✘ Sometimes standard
<b>UL LISTED &amp; IP44 RATED</b>	✔ All components UL listed, rated and suitable for damp locations	✔ Industry standard
<b>ECO-PERFECT™</b>	✔ Lead and copper free	✘ Upgrade \$\$\$
<b>RoHS COMPLIANT</b>	✔ Free of 10 hazardous elements	✔ Industry standard
<b>WINGITS® PATENTED FASTENERS</b>	✔ Included with each mirror to guarantee installation and eliminate the need for blocking	✘ Not offered

# LIGHTING & ENERGY

## COLOR RENDERING INDEX (CRI)



**LOW CRI**  
below 80

**HIGH CRI**  
85+

## COLOR TEMPERATURE (KELVIN)



Typical Hospitality Kelvin: 2,700K - 3,000K

### PRECISE-VIEW™

The perfect combination of task and ambient lighting, SilverShield™ backing, diffusers, top quality LED driver, and CRI 85+ creates a beautiful lighting experience with proper light and shade for optimal clarity and comfort.

### HIGH EFFICACY

100+ Lumens per watt LEDs. Our crystal clear light is highly efficient and uses minimal power, saving on energy costs every day.

### COLOR TEMPERATURE

A wide range of color temperature options available from 3000k-6500k.

### LIMITED WARRANTY

Highly efficient LED driver uses less energy and is warranted for 10 years.



**THE WORLD'S STRONGEST FASTENER®**  
Included with all Winglts® Lighted Mirrors for quick and easy installation



### SAFETY-BACKED GLASS

Vinyl backing protects guests in the event the mirror shatters, eliminating injuries and liabilities.

### PATENTED FASTENERS

Our patented fasteners allow easy installation in hollow walls without the need for structural blocking.

### 2-PIECE MOUNTING SYSTEM

Easy 2-piece mounting system consists of mirror and chassis.

### STAINLESS STEEL SAFETY LOCK

Ensures durability and prevents unauthorized mirror removal.

### WATER-TITE™

Silica gasketing around the perimeter of the mirror creates a Water-Tite™ seal suitable for damp locations.

### PRINT-PROOF™

Fingerprint resistant finish keeps the mirrors looking brand new and reduces cleaning time.

GET THE ENTIRE MIRROR CATALOG:  
[SALES@WINGITS.COM](mailto:SALES@WINGITS.COM)

# SUSTAINABILITY

## ENERGY SAVING

Energy-efficient LEDs save on energy costs versus alternative lighting types.

## ECO-PERFECT™

Sustainable mirrors are environmentally friendly, copper & lead free.

## SILVERSHIELD™

Lead-free, high-density SilverShield™ backing eliminates any distortion for a crystal clear mirror.

## RoHS COMPLIANT

Does not contain the 10 hazardous elements specified by the Restriction of Hazardous Substances Directive.



## WINGITS® CARES

Wingits® is committed to managing environmental impact as an integral part of our operations. It is our policy to ensure the environmental integrity of our processes and facilities at all times. We strive to improve our environmental performance over time and to initiate additional projects and activities that will further reduce our impact on the environment in a responsible way. Our commitment to the environment extends to our customers, our staff, and the communities in which we operate.

# WINGITS® LIGHTED MIRRORS

Choose from five different styles or work with us to develop a custom mirror to fit any design.

## ALTAREN™



WATxxyyLED

24" x 36"	42" x 42"
28" x 36"	44" x 36"
36" x 36"	48" x 36"
36" x 42"	60" x 36"
42" x 36"	Custom*

## ALVISTA™



WALxxyyLED

24" x 36"	42" x 42"
28" x 36"	44" x 36"
36" x 36"	48" x 36"
36" x 42"	60" x 36"
42" x 36"	Custom*

## EVORA™



WEVxxyyLED

24" x 36"	42" x 42"
28" x 36"	44" x 36"
36" x 36"	48" x 36"
36" x 42"	60" x 36"
42" x 36"	Custom*

## MATIRI™



WMRxxyyLED

24" x 36"	42" x 42"
28" x 36"	44" x 36"
36" x 36"	48" x 36"
36" x 42"	60" x 36"
42" x 36"	Custom*

## MOLVANO™



WMOxxyyLED

24" x 36"	42" x 42"
28" x 36"	44" x 36"
36" x 36"	48" x 36"
36" x 42"	60" x 36"
42" x 36"	Custom*



MATIRI™ and MOLVANO™ styles are ADA Compliant



GET THE ENTIRE MIRROR CATALOG:  
SALES@WINGITS.COM

# NEW REVOLUTIONARY MODULAR CLOSET SYSTEM



## WORLD'S STRONGEST FREE-STANDING CLOSET SYSTEM with TrueFit™ Technology

Custom cubby sizes and configurations available to suit any space.

Fits 3' - 6' closets.

Field modifiable to create a custom closet layout.

Structural clip system paired with WingIts® patented fastening technology does not require blocking or floor support.

18/8 (304) stainless steel hanging rod will support even the heaviest garments and will not bend or sag.

Available in a variety of custom laminate finishes to match any existing case goods.



## CREATE A CUSTOM CLOSET, INSTALL IT IN UNDER 1 HOUR



1. Unpack the closet system including the preassembled structural cubby



2. Install the cubby in your selected location



3. Install shelf and hanging rod. Easily modify pieces to fit cubby location

# WINGITS® COMPLETE CLOSET SYSTEM

## THE SAFE, REVOLUTIONIZED WINGITS®: CREATORS OF THE CLOSET SAFE

StorSafe™ replaces a traditional safe with an integrated, wireless, locking safe that is part of your closet system.

### PEACE OF MIND

Securely store items at any time

### ECO-SUSTAINABLE

Does not require batteries or wiring

### TAMPER-PROOF LOCK

Anti-pick and no plastic components

### USER-FRIENDLY DESIGN

Simply lock and go

Beautiful, integrated design matches the rest of the closet system for a designer aesthetic.



### Designer Finish Options



## SAFELY STORE ITEMS FOR ANY OCCASION!

Going to the gym?  
Store your purse!

Leaving your room?  
Store your passport!

GET THE ENTIRE CLOSET CATALOG:  
[SALES@WINGITS.COM](mailto:SALES@WINGITS.COM)



The Extended Stay

CHOOSE FROM OUR MOST POPULAR CLOSET DESIGNS OR CUSTOMIZE YOUR DESIGN TO FIT ANY SPACE



The Vacationer



The Weekender



The All Inclusive



The Hideaway



The Studio



The Boutique

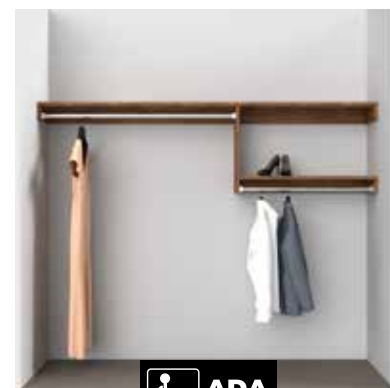

The Resort

**STANDARD UNIT**

72" W, 60" H,  
(4) 12" W x 15" H  
CUBBIES

**ADD A SHELF**

[less than 35" wide]

OPTION A  
SHELF WITHOUT ROD

---

OPTION B  
SHELF WITH ROD

**ADD A SHELF**

[more than 36" wide]

OPTION A  
SHELF WITHOUT ROD

---

OPTION B  
SHELF WITH ROD

**ADD A CUBBY**

ADD 1 CUBBY

**WIDEN CUBBIES**

WIDEN 12" CUBBIES  
TO 18" WIDE CUBBIES

**ADD A DOOR**

OPTION A  
ADD 1 CUBBY DOOR

---

OPTION B  
ADD 1 CUBBY DOOR  
WITH StorSafe™

GET THE ENTIRE CLOSET CATALOG:  
[SALES@WINGITS.COM](mailto:SALES@WINGITS.COM)

# INVIDIA™ SOLID SURFACE BATH ACCESSORIES

WingIts® INVIDIA™ Collection is a combination of the unmatched structure and durability of our world-renowned stainless steel and over 1000+ colors of solid surface material.

INVIDIA™ can be carved to any design, elevating the bathroom aesthetic with a multitude of finish & design options to deliver a luxury look without exceeding your budget.



ABOVE: POLISHED STAINLESS STEEL PAIRED WITH MEGANITE® MT. GRIGIO



ABOVE: POLISHED STAINLESS STEEL PAIRED WITH MEGANITE® MT. CARRARA

# NEW INNOVATION, INFINITE DESIGN POSSIBILITIES

SINK SHROUD



NICHE



DISPENSER HOLDER



VERSA SHELF



VERSA SHELF



HOT BEVERAGE CENTER



HAIR DRYER HOLDER



GET THE ENTIRE SOLID SURFACE CATALOG:  
SALES@WINGITS.COM

# MODERN ELEGANCE™

*Sleek, understated lines and soft rounded edges are sure to complement any design scheme.*



WMEDRH Double Robe Hook

WMESBRH Single Button Robe Hook

WMESBRH Single Button Robe Hook

WMESRH Single Robe Hook



WMETRING Towel Ring



WMETB Towel Bar



WGB5ME Grab Bar

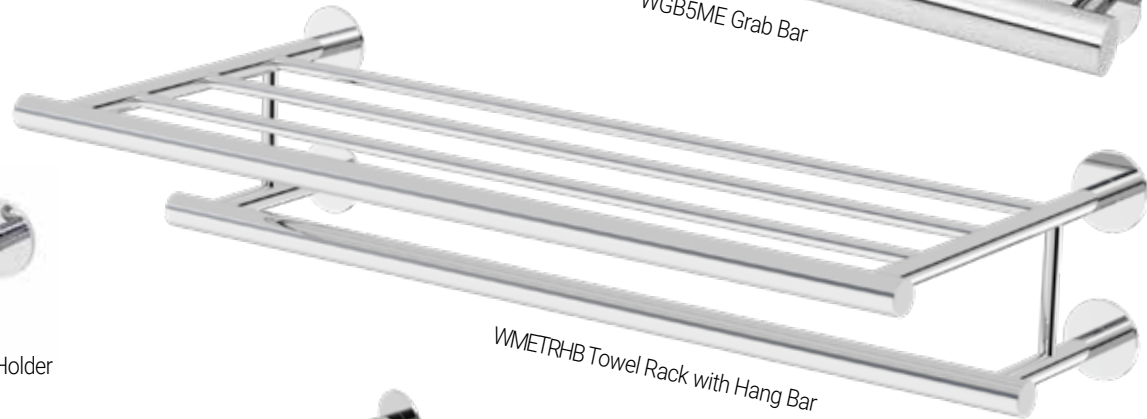

WMETRHB Towel Rack with Hang Bar



WMEHDH Hair Dryer Holder



WMEEUTPH Euro Toilet Paper Holder



WMEGLSF Glass Shelf



WMEDHTPH Double Horizontal Toilet Paper Holder

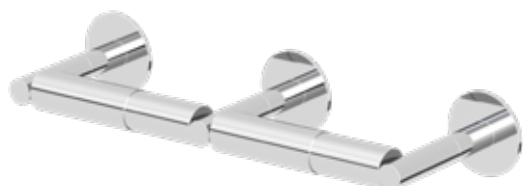

WMEDTPH Double Toilet Paper Holder



WMETPH Single Toilet Paper Holder

# MODERN ELEGANCE™ BOLD

*A dual-step design adds a bold touch to the sleek, modern lines of our top-selling collection.*



WXEBSCH Single Coat Hook

WXEBSBRH Single Button Robe Hook

WIEBDCH Double Coat Hook



WMEBTB Towel Bar



WGB5MEB Grab Bar

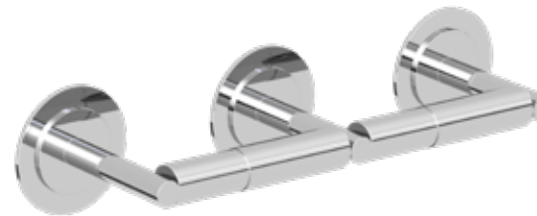

WMEBDTPH Double Toilet Paper Holder

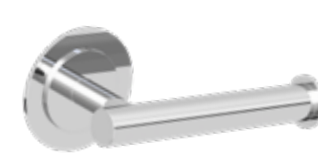

WMEBHVTPH Horizontal/Vertical Toilet Paper Holder



WMEBTPH Single Toilet Paper Holder



WMEBTRING Towel Ring



MAW35 MASTER Anchor™ Fastener

**THE WORLD'S STRONGEST FASTENER®**  
Available for all WINGITS® products for quick and easy installation

Seamless edges and round tubing create a timeless look that will never go out of style.

The perfect pairing of squared accents on rounded tubing creates a modern yet transitional style.

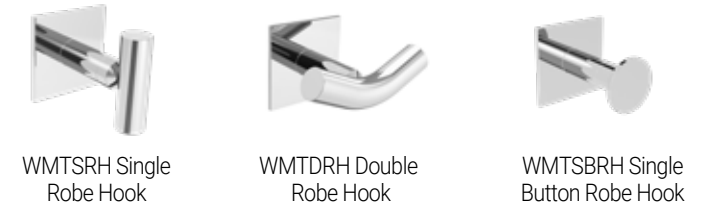

WIETRINGSR Towel Ring (with square ring and wire)



WIETRINGSRR Towel Ring (with square ring and round wire)



WIEHVTPH Horizontal/Vertical Toilet Paper Holder



WIEEUTPH Euro Toilet Paper Holder



WIETB Towel Bar



WGB5IE Grab Bar



WIETRHB Towel Rack with Hang Bar



WIEFS Floating Shelf



WIEFSPR Floating Shelf with Perimeter Rail

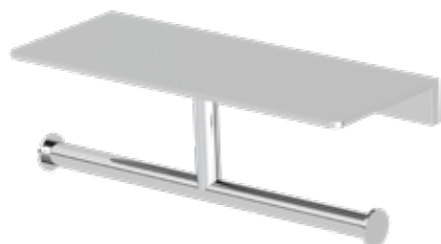

WIEDHPH Double Horizontal Toilet Paper Holder



WIEDHVTPH Double Horizontal/Vertical Toilet Paper Holder



WMTTB Towel Bar



WGB5MT Grab Bar



WMTTRHB Towel Rack with Hang Bar



WMTGLSF Glass Shelf

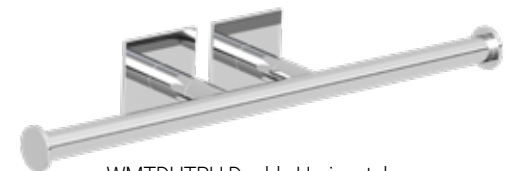

WMTDHTPH Double Horizontal Toilet Paper Holder

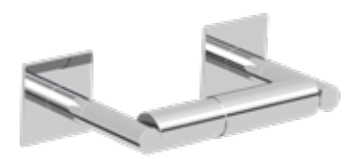

WMTTPH Single Toilet Paper Holder



WMTDTPH Double Toilet Paper Holder



WMTHVTPH Horizontal/Vertical Toilet Paper Holder



WMTTRING Towel Ring



WMTHDH Hair Dryer Holder



WMTEUTPH Euro Toilet Paper Holder

# INFINITE TRANSITIONAL™

Seamless edges and round tubing with squared accents creates a balanced look.

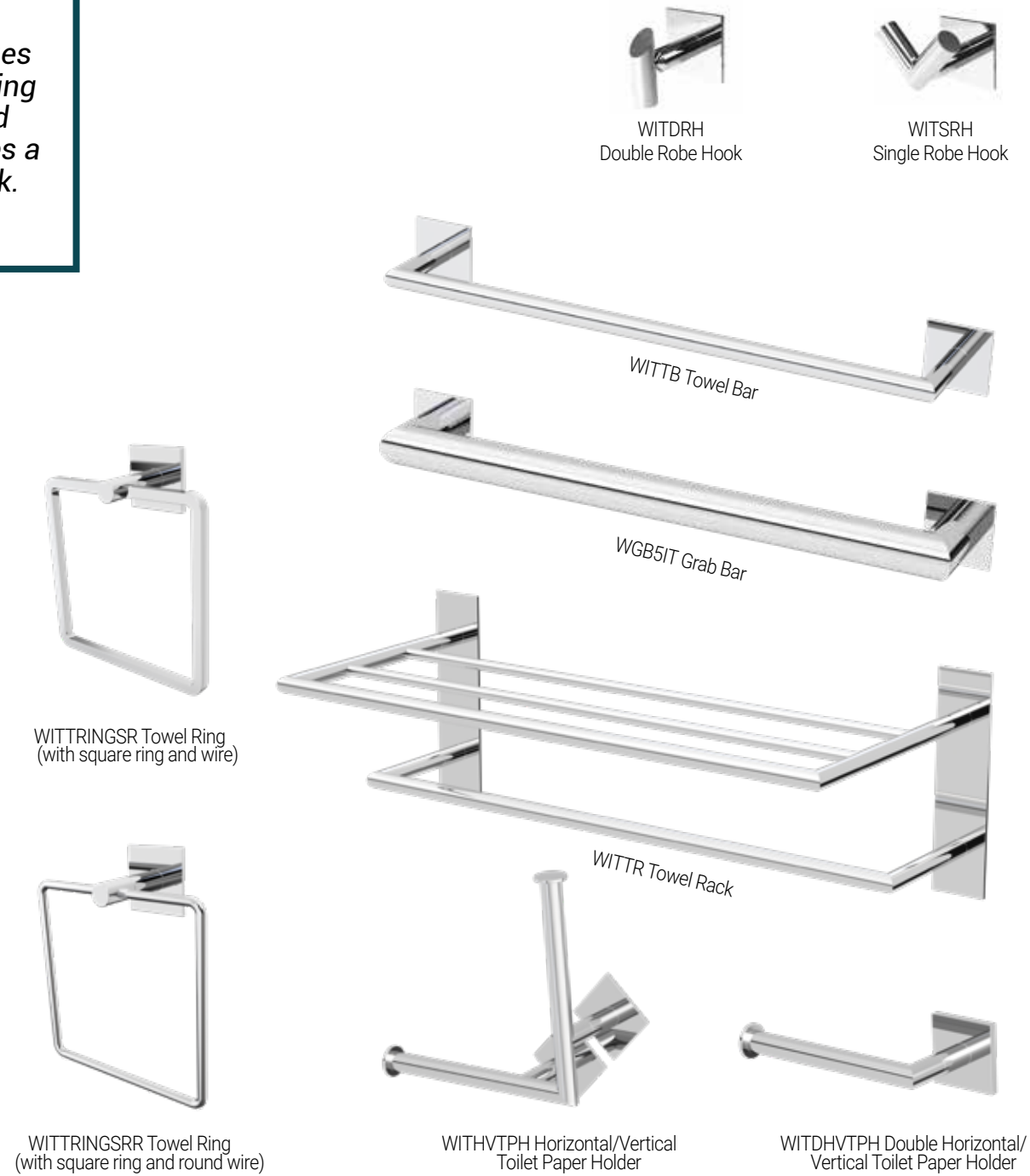

# INFINITE SQUARED™

Seamless design with squared tubing creates an angular look with a contemporary flair.

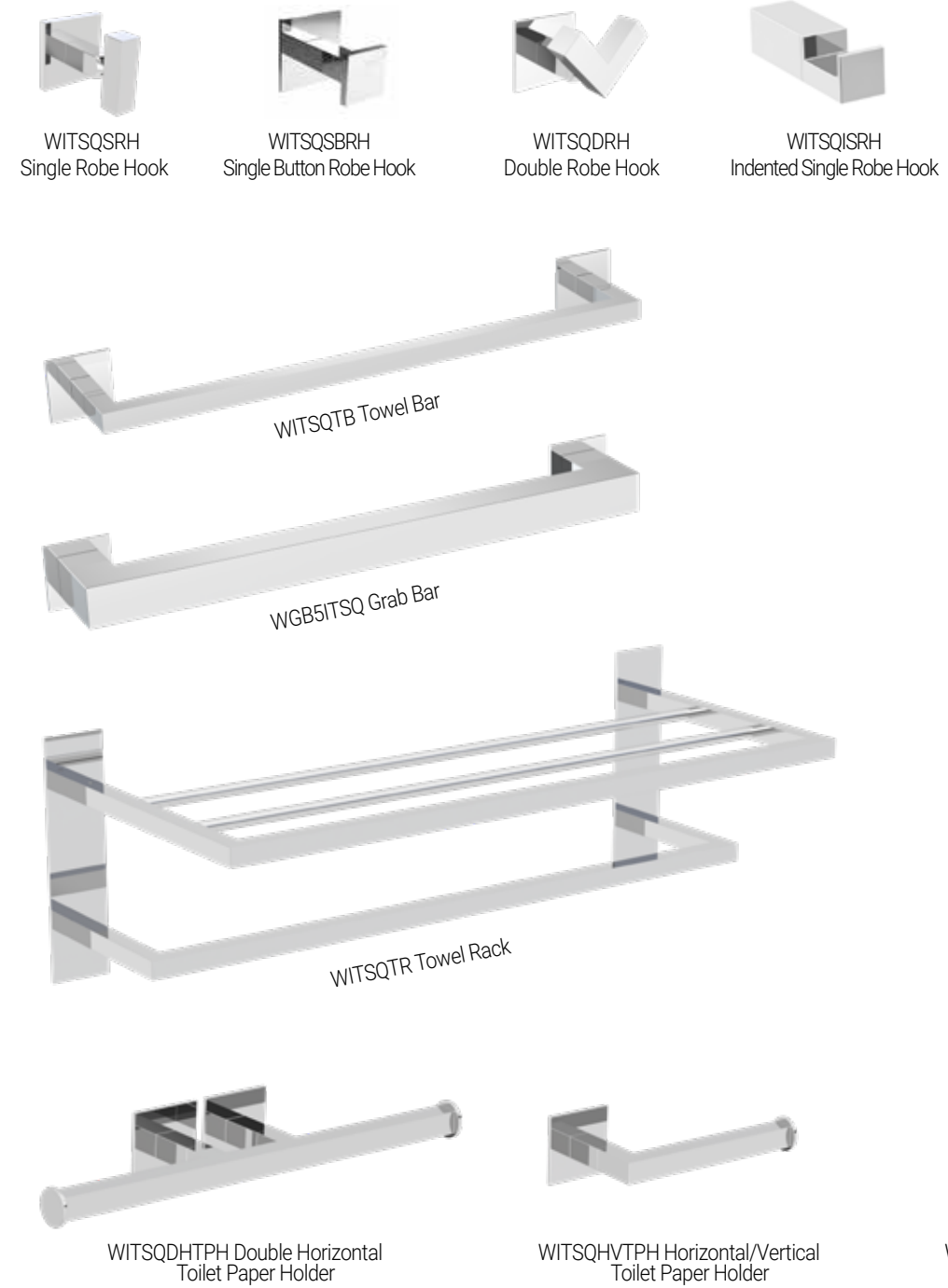

MAW35 MASTER Anchor™ Fastener

**THE WORLD'S STRONGEST FASTENER®**  
Available for all WINGITS® products for quick and easy installation

# MAX ELEGANCE™

*Sleek, understated lines and substantial features complement any design scheme.*



# BOLD TRANSITIONAL™

*Crisp lines coupled with smooth curves make each piece a statement in this collection.*

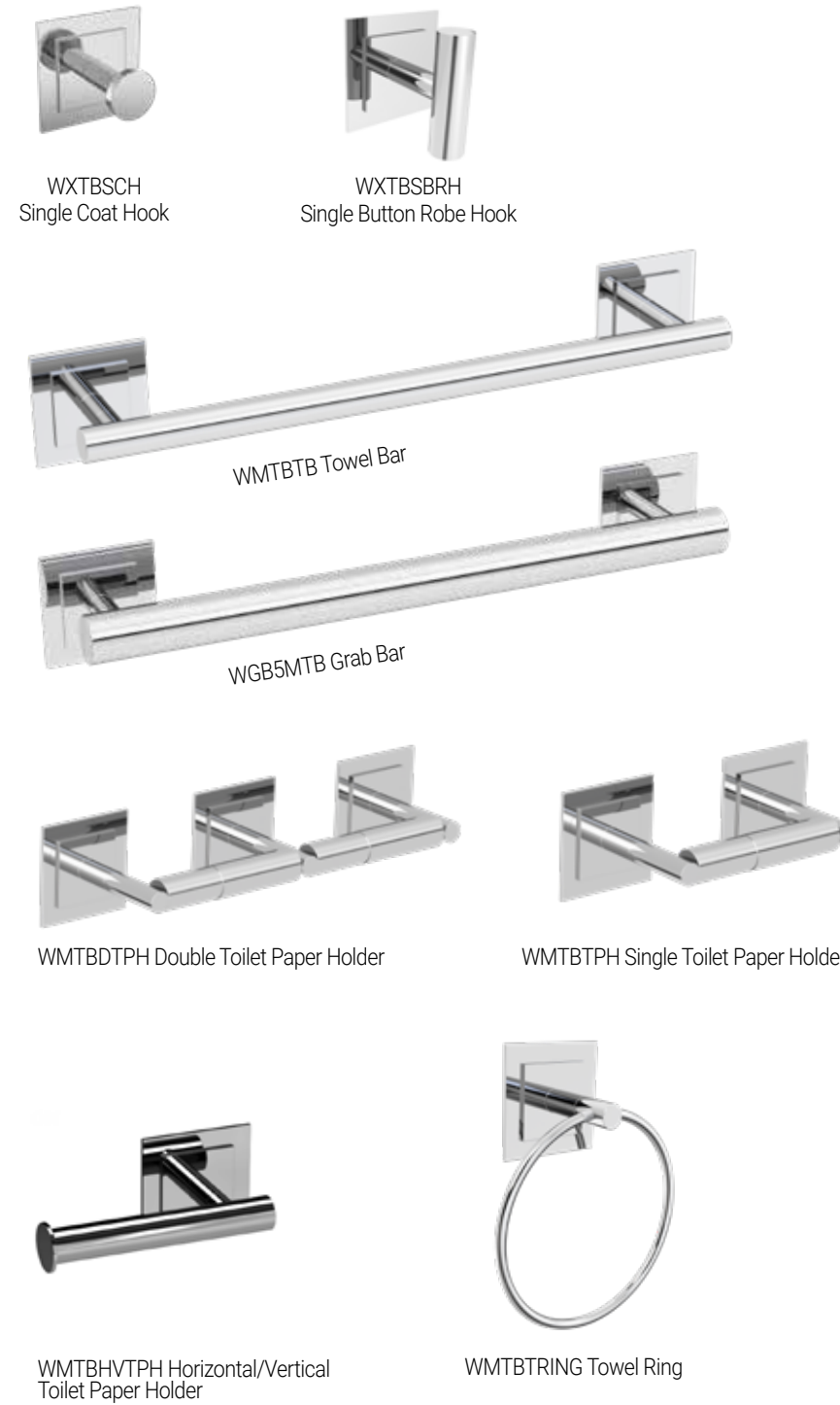

MAW35 MASTER Anchor™ Fastener

**THE WORLD'S STRONGEST FASTENER®**  
Available for all WINGITS® products for quick and easy installation

## SHEER ELEGANCE™

*Simple, round edges with flat faces offers a fresh take on modern, elegant design.*



WSEGSBRH Single Button Robe Hook



WSEGDBRH Double Button Robe Hook



WSEGTB Towel Bar

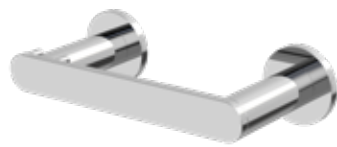

WSEGTPH Pivoting Toilet Paper Holder



WSESSPS8 Shower Shelf



WSEGDTB Double Towel Bar

## RADIAL ELEGANCE™

*New, dual-step design brings boldness and adds class to any setting.*



WREBG2DRH Double Robe Hook



WREBG2SBRH Single Button Robe Hook



WREBG2TB Towel Bar



WGB5REBG2 Grab Bar



WREBG2TPH Single Toilet Paper Holder



WREBG2HVTPH Horizontal/Vertical Toilet Paper Holder

## SHEER SQUARED™

*A refined approach to bath design with squared flanges and bars.*



WSSQGBRH Double Button Robe Hook



WSSQGBRH Single Button Robe Hook

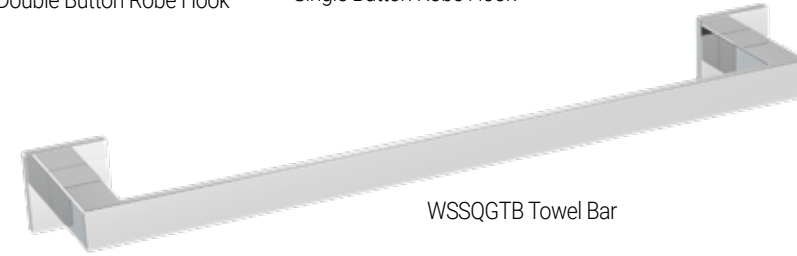

WSSQGTB Towel Bar



WSSQGTB Double Towel Bar

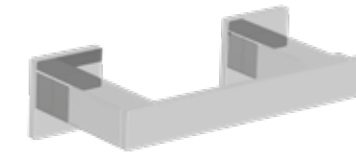

WSSQGTPH Pivoting Toilet Paper Holder

## SIMPLE SQUARED™

*A refined approach to bath design with squared flanges and bars.*

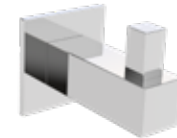

WSMPSQRH Single Robe Hook

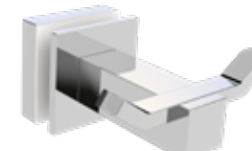

WSMPSQDRH Double Robe Hook

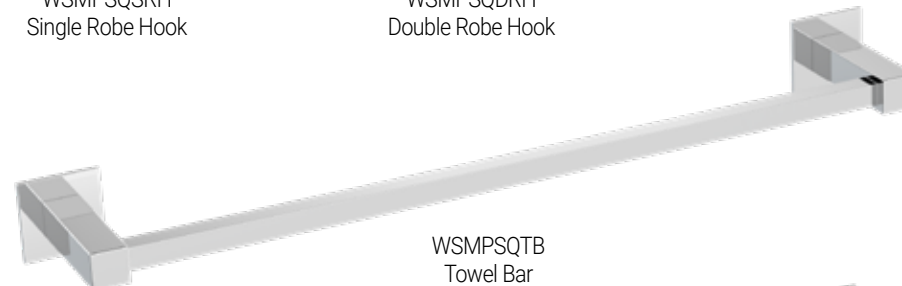

WSMPSQTB Towel Bar

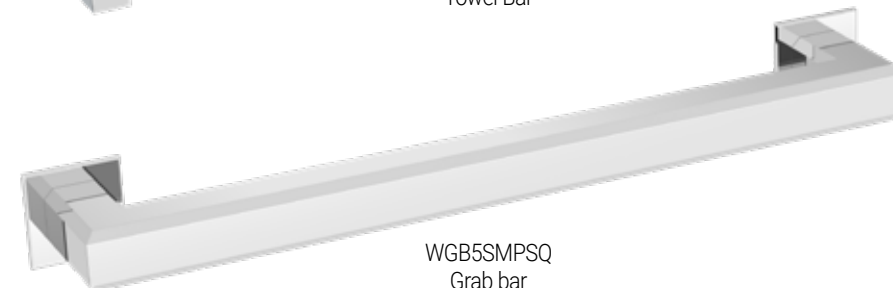

WGB5SMPSQ Grab bar



MAW35 MASTER Anchor™ Fastener

**THE WORLD'S STRONGEST FASTENER®**  
Available for all WINGITS® products for quick and easy installation

# LINEAR TRANSITIONAL™

*Straight edges and clean lines, this geometric collection adds a minimalist touch to any design.*



WLTDRH  
Double Robe Hook



WLTSRH  
Single Robe Hook



WLTTB Towel Bar

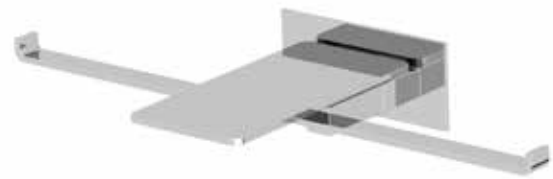

WLTDHPT  
Double Horizontal Toilet Paper Holder with Phone Tray



WLTDHTPH  
Double Horizontal Toilet Paper Holder



WLTHTPH  
Horizontal Toilet Paper Holder

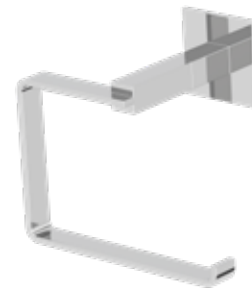

WLTEUTPH Euro Toilet Paper Holder



WLTSTPH  
Toilet Paper Holder with Spindle

# CANTED ELEGANCE™

*Canted faces accent the rounded edges for a bespoke, modern look.*



WCNDESBRH  
Single Button Robe Hook



WCNDEDRH  
Double Robe Hook



WCNDETB  
Towel Bar



WGB5CNDE  
Grab Bar



WCNDETPH  
Double Toilet Paper Holder



WCNDEDTPH  
Double Horizontal Toilet Paper Holder



WCNDETPH  
Single Toilet Paper Holder



MAW35 MASTER Anchor™ Fastener

**THE WORLD'S STRONGEST FASTENER®**  
Available for all WINGITS® products  
for quick and easy installation

# BOLD & GRAND BASES

Winglts® offers several different base design options:

GRAND Base option which is double the thickness of our standard base.

BOLD Base option incorporates two standard bases, one larger in diameter, stacked on top of each other.

BOLD Double GRAND Base is a combination of the BOLD and GRAND base options.



WINGITS®  
Standard Base



WINGITS®  
GRAND Base

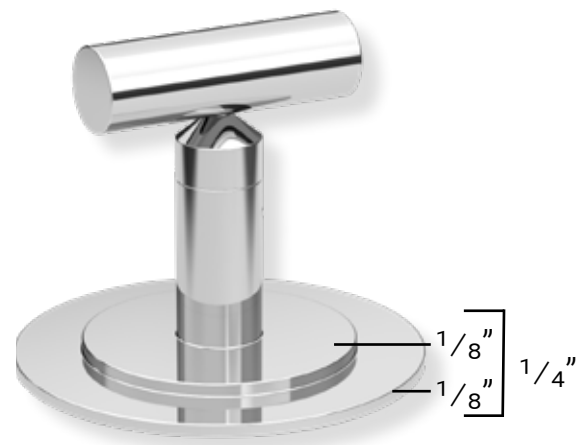

WINGITS®  
BOLD Base

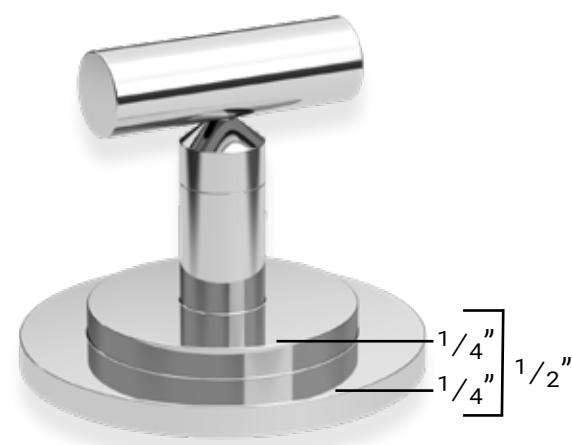

WINGITS®  
BOLD Double GRAND Base

Only Winglts® crafts polished stainless steel grab bars, providing unmatched style and security in every design.

Clean flowing lines accent the durability and distinction.

Engineered to all meet building codes, and exceed ADA, 2010 ADAAG and 2017 ANSI standards.

Patented BridgeBind™ technology creates the ultimate structure.

Minimal crevices for dirt to collect keeps these grab bars maintenance free.



GBWME40 Designer Grab Bar Fastener

RATED UP TO 600 LBS.  
When installed with Winglts® patented GBWME40 Designer Grab Bar fasteners in drywall with tile.

# DESIGNER GRAB BARS



## STANDARD™ GRAB BARS

Anti-slip grab bars repel dirt and bacteria.

Winglts® exclusive Diamond Knurling pattern offers an excellent grip, yet is gentle on sensitive skin.

Diamond Knurling and Peening are both available, which feature a better gripping surface than a typical smooth metal surface.

Pure 18/8 (304) stainless steel tubing.



## PLATINUM™ GRAB BARS

All parts are 18/8 (304) stainless steel, tubing is 18-gauge (1.2mm).

Heavy cast stainless steel threaded flanges tighten to form a waterproof seal.

Meets or exceeds all building codes, ADA Criteria, 2010 ADAAG and 2017 ANSI standards.



GBW40 Grab Bar Fastener

RATED UP TO 800 LBS.  
When installed into adequate structural blocking, or with WINGITS® GBW40 THE BEAST™ Grab Bar fasteners in drywall with tile

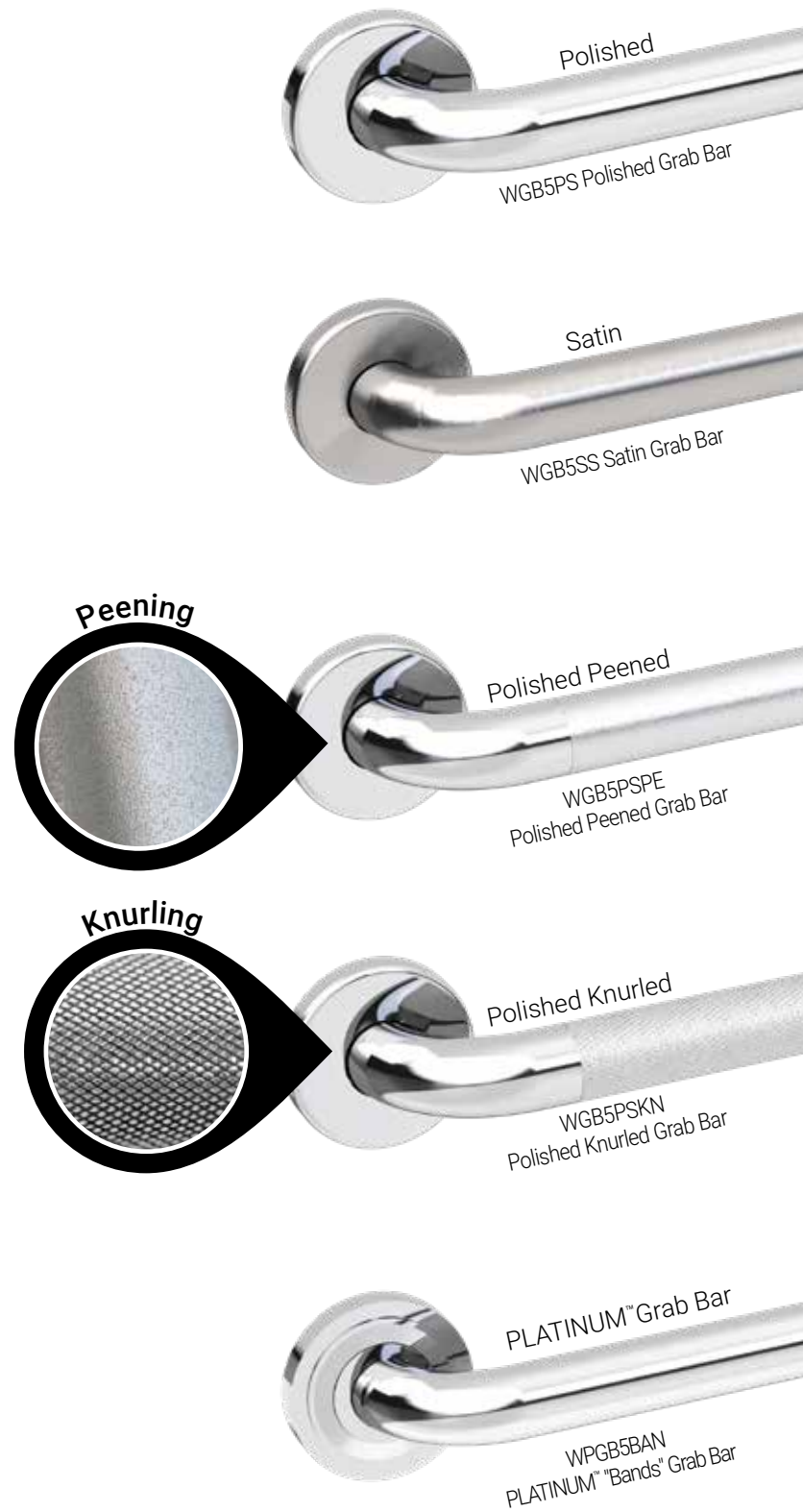

## POLY PAINTED GRAB BARS



WINGITS® EXCLUSIVE SureGrip™ features anti-slip silica added into the paint for a superior gripping surface.



Exceeds all building codes, ADA, 2010 ADAAG and 2017 ANSI standards.

Pure 18/8 (304) stainless steel tubing.

Polyester Fibrous Paint, a three-component paint, utilizes a resin + catalyst + accelerant for the ultimate finish.

Paint will never fade or show signs of wear.

Available in any RAL color to match your design scheme.

Winglts® will work with you to create a custom product or finish if desired.

Suitable for indoor and outdoor use.

# PURE ELEGANCE™

Pure 18/8 (304) stainless steel tubing covered with a nylon sheath.

Soft and warm to the touch.

Exceeds all building codes, ADA, 2010 ADAAG and 2017 ANSI standards.

Excellent non-slip and antimicrobial gripping surface for hands.

Exceeds safety rails in hazardous locations criteria as well as barrier free accessibility guidelines, including ADAAG, for structural strength.



PUTB30 Tub Bench



PUEX28RH L-Shaped Right Handed Shower Seat



PUEX32LH L-Shaped Left Handed Shower Seat

PURE Elegance™ shower seats and tub benches exceed minimum 250 lbs. load requirement per the 2010 ADAAG and 2017 ANSI Standards.

Stainless steel mount plate and hinge rated up to 450 lbs.

Beautifully designed and warm to the touch.

Installs directly into adequate structural blocking to prevent liability.

Heavy nylon antimicrobial sheath exterior with directional slats.

Folds up neatly after use.

**PURE Elegance™ Shower Seats and Tub Benches are NOT compatible with WingIts® fasteners and MUST be installed into adequate structural blocking**

# SHOWER SEATS



800 lbs. load capacity rating for legs-to-floor designs when installed into adequate structural blocking, or with WINGITS® GBW40 Grab Bar Fasteners in drywall with tile.

WingIts® shower seats are the easiest to lift on the market.

The only shower seats that comply with the 2010 ADAAG and 2017 ANSI Standards Five Pound Maximum Lift Force requirement (Code 309.4).

Feature phenolic tops and structural stainless steel carriage construction.

Built to accommodate any bath configuration.



## GBW40 Grab Bar Fastener

- NEVER loosens—The World's Strongest Fastener®
- Rated up to 800 lbs. in drywall with tile
- Over 3 MILLION installations without a single failure.

The GBW40 has been specified by every major hotel chain in North America in the last 20 years.



# SHOWER SEATS WITH LIFT-ASSIST™

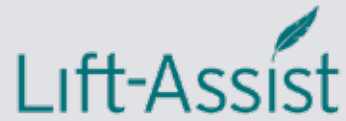

The only shower seats that comply with the 2010 ADAAG and 2017 ANSI Standards Five Pound Maximum Lift Force Requirement. (Code 309.4)

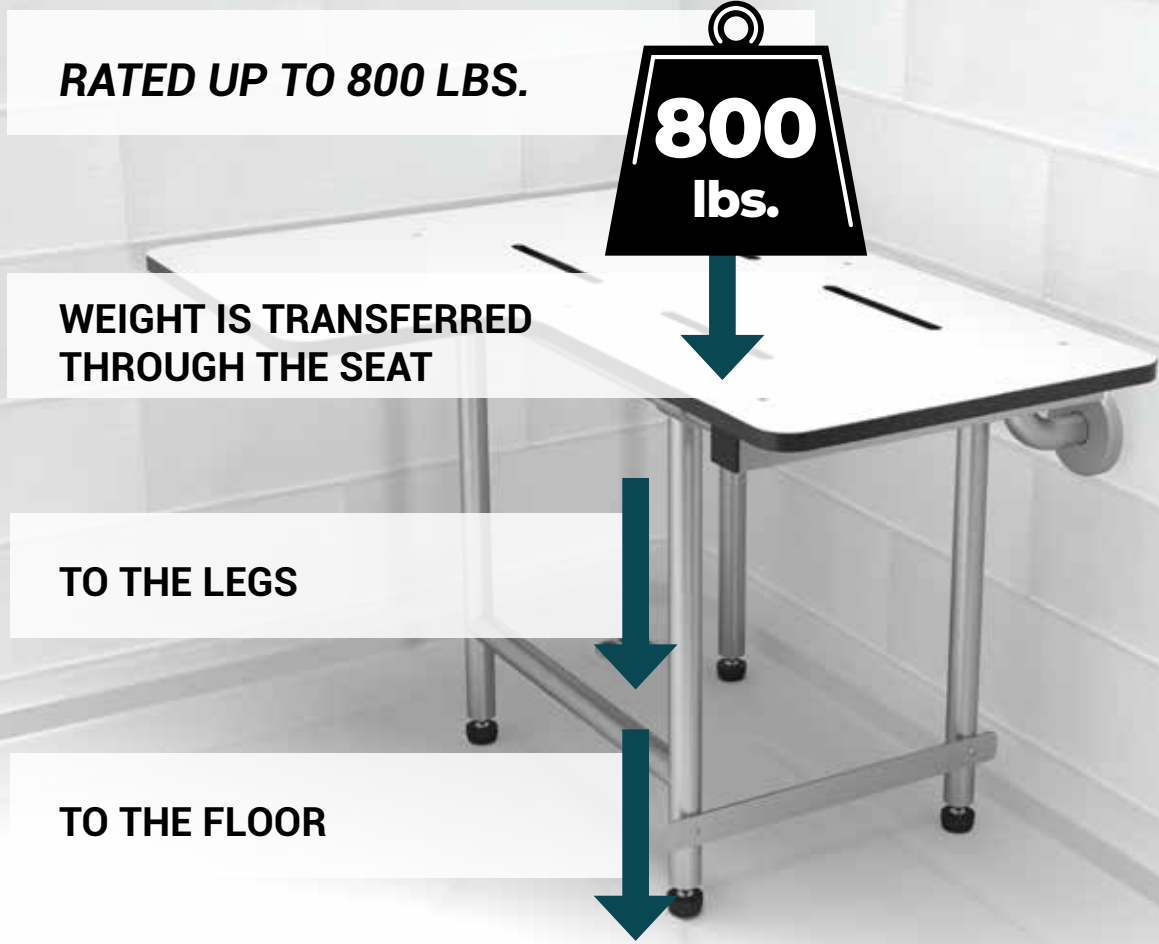

Winglts® products are developed to meet ADA and building codes while exceeding all load requirements to ensure durability and minimize liability. We engineer our products to handle vector, vibratory, & moment forces while distributing the loading to ensure durability.

*Winglts® will NOT make or sell items that expose our partners to liability— for example, our phenolic/ stainless steel shower seats transfer the weight through structural legs into the floor because angle wall brackets are a liability! Additionally, our shower seats can be installed with our “BEAST” fastener when blocking is not available.*

*Winglts® – the Solution Company!*



# PORTABLE TUB BENCH

Meets ADA Criteria 2010 ADAAG & 2017 ANSI Standards



WHPTB  
Portable Tub Bench

The 2010 ADAAG guidelines state that the top of bathtub seats shall be 17" (430 mm) minimum and 19" (485 mm) maximum above the finished bathroom floor.

Adjustable Tub Clamp: The height of the clamp assembly with the phenolic top is 3.5" (3" for the lift and 1/2" for the phenolic top). If the tub height is 13.5" – 15.5" AFF, this portable tub bench can be used and meets code of the 17" minimum – 19" maximum AFF.

The width of a removable in-tub seat shall be 15" (380 mm) minimum and 16" (405 mm) maximum.

The seat shall be capable of secure placement. Feet must rest on flat surface of tub for proper fit, not on radius of tub.

Rubber feet are adjustable for various surfaces.

Available in White Phenolic or Teak Phenolic, Padded Naugahyde is NOT an option with this bench.

# TUB BENCHES

Meets all building codes, and exceeds ADA criteria and 2010 ADAAG and 2017 ANSI standards.

Available in a 1-Piece Phenolic material, Phenolic Slats or Padded Naugahyde.

Extremely durable, non-porous, and anti-microbial.

Exceeds 250 lbs. load rating when installed into adequate structural blocking, or with WINGITS® GBW40 Fastener for hollow wall installation in drywall with tile.



Permanent Rear Mount Tub Bench installed with GBW40 Grab Bar Fastener

## GBW40 Grab Bar Fastener

- NEVER loosens—The World's Strongest Fastener®
- Water & fire resistant
- Over 3 MILLION installations without a single failure

The GBW40 has been specified by every major hotel chain in North America in the last 20 years.

## PERMANENT REAR MOUNT TUB BENCHES

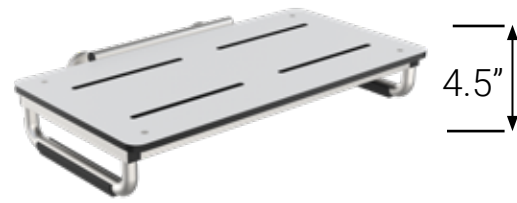

With Skis  
WBTRS Rectangular Rear Mount Tub Bench with Skis

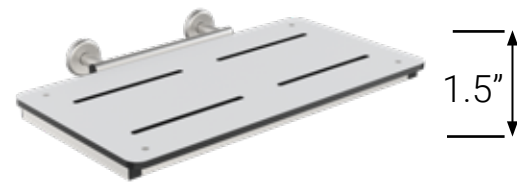

Without Skis  
WBTR Rectangular Rear Mount Tub Bench

**Permanent Bench less Skis** will be needed for ADA height tubs where the AFF (above finished floor) height ranges between **15.5" - 17.5"** to meet ADAAG Height Requirement

**Permanent Bench with Skis** will be needed for Standard height tubs where the AFF (above finished floor) height ranges between **12.5" - 14.5"** to meet ADAAG Height Requirement

## PERMANENT END MOUNT TUB BENCHES

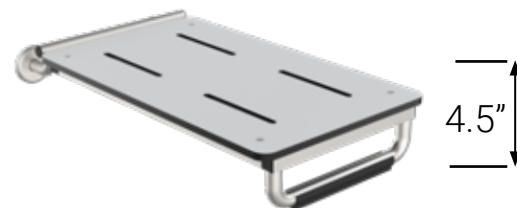

With Ski  
WBTES Rectangular End Mount Tub Bench with Skis

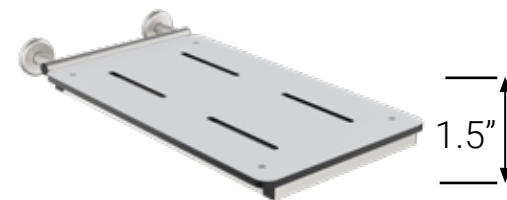

Without Ski  
WBTE Rectangular End Mount Tub Bench

# VERTICAL TOWEL RACKS & CENTERS

MODERN Elegance™  
Vertical Towel Rack Installation



Installed with  
WINGITS® MASTER  
Anchor™ fasteners

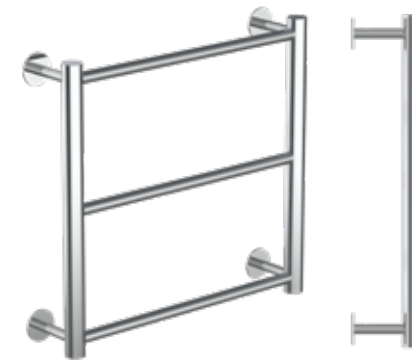

MODERN Elegance™  
WMETRV Vertical Towel Rack



MODERN Elegance™  
WMEVTC Vertical Towel Center

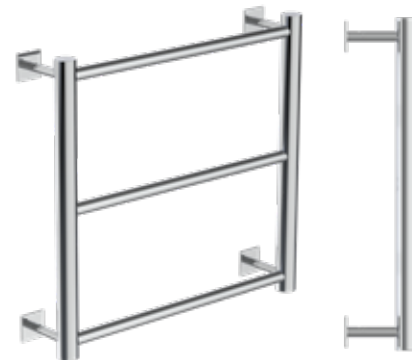

MODERN Transitional™  
WMTTRV Vertical Towel Rack

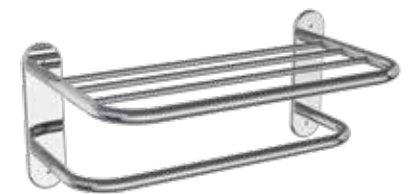

WMR MASTER™ Towel Rack



MAW35 MASTER Anchor™ Fastener

**THE WORLD'S STRONGEST FASTENER®**

Available for all WingIts® products for quick and easy installation

## CONTOUR™ SHOWER RODS

Patented hidden multi-vector interlock system guarantees the rod won't loosen or sag.

22-gauge stainless steel.

Oval and rectangular tubing is durable, strong and prevents rotational forces.

Increases shower room by 25%.

No unsightly joints or exposed hinges to re-tighten.

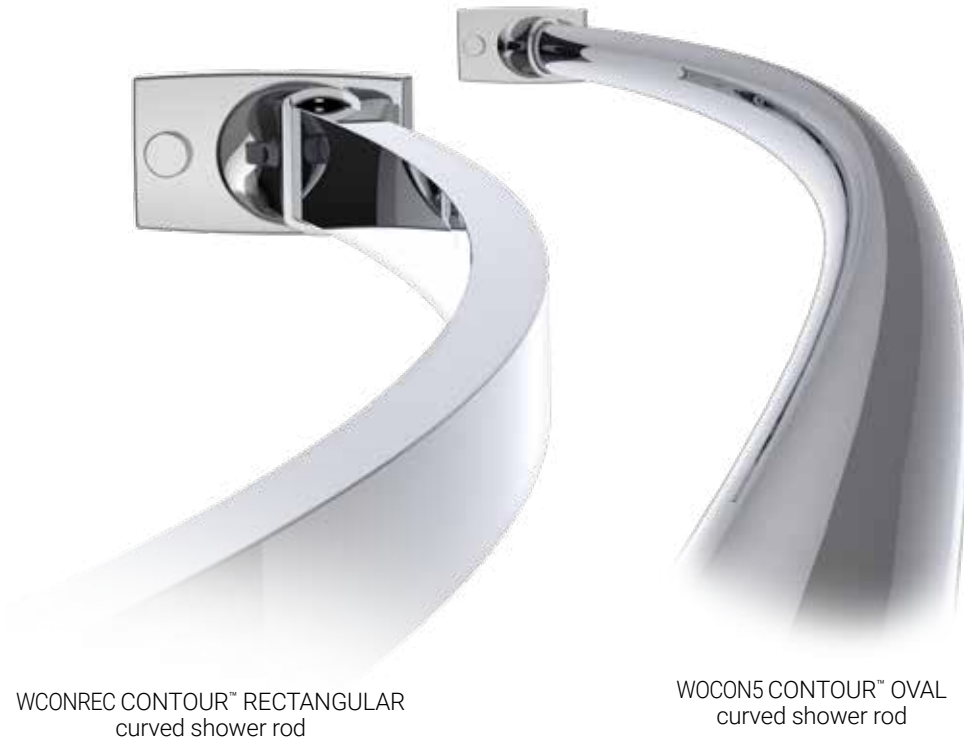

WCONREC CONTOUR™ RECTANGULAR curved shower rod

WCON5 CONTOUR™ OVAL curved shower rod

## CONTOUR™ TRIROD™

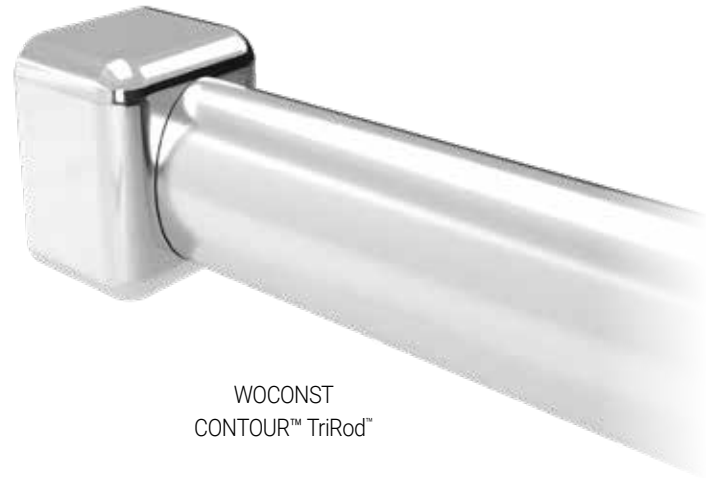

WCONST CONTOUR™ TriRod™

### CONTOUR™ TriRod™

3-in-1 rod can be used as towel bar, shower rod, or closet rod.

Can be modified to accommodate any closet or bathroom up to 8'.

Spring feature bracket-cover interlock secures rod and creates a seamless aesthetic.



MAW35 MASTER Anchor™ Fastener

**THE WORLD'S STRONGEST FASTENER®**

Available for all Winglts® products for quick and easy installation

## CONTOUR™ ACCESSORIES & FOOTRESTS

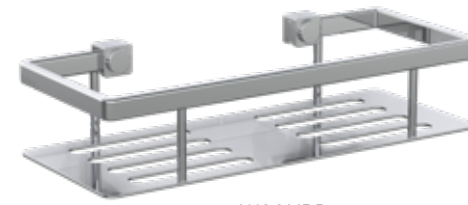

WCONRB Rectangular Basket

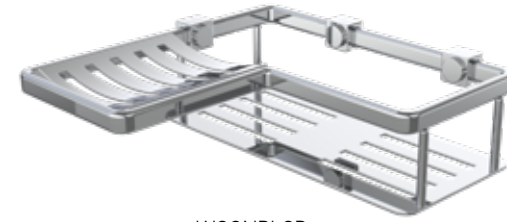

WCONBLCB Bi-Level Corner Basket



WCONRBSD Rectangular Basket with Soap Dish

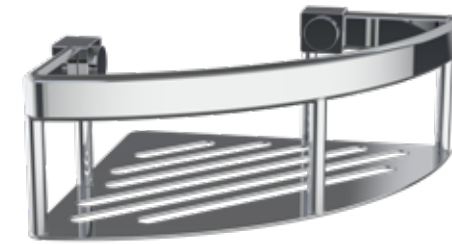

WCONCB Corner Basket



WRIGS14 Glass Shelf



Patented hidden bracket system



WFRTC Tubular Corner Foot Rest

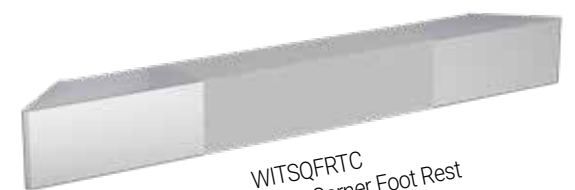

WITSQFRTC Squared Tubular Corner Foot Rest

When installed, shelves and baskets do not touch the wall.

Wall and corner design options available in polished stainless steel, satin stainless steel, or a range of metallic and color finishes.

Crevices and joints are eliminated, making these shower baskets easy to clean.

Shower baskets include WINGITS® MASTER Anchors™ for guaranteed, dependable installation.

## ELITE STUDIO™ SHELVES WITH LED

Structural hardwood shelves rated up to 50 lbs. per shelf.

Installs in minutes with Winglts® fasteners (included).

Light mortised into shelf —all necessary components are included.

Exclusive industry leading LED and components have up to 50,000 hours life expectancy.



Smoked Oak



Loft Oak

## ELITE STUDIO™ FLOATING SHELVES WITH LED

*Industrial grade “plug and play” technology, featuring fully solid-state electronics rated beyond 50,000 hours*

Pre-installed recessed LED fixture, fully UL compliant.

Exclusive industry leading LED and components have up to 50,000 hours life expectancy.

Patented dimmer switch incorporates precision solid state driver.



WFBPS  
Buffet/Pantry Shelves with LED Strip

MAW35  
MASTER Anchor™ Fastener



ML-003  
Floating Shelf with Recessed LED System



MAW35 MASTER Anchor™ Fastener

**THE WORLD'S STRONGEST FASTENER®**  
Available for all Winglts® products for quick and easy installation

# FLOATING SHELVES

Weight-rated to hold up to 50 lbs. per shelf while using WingIts® fasteners or when properly installed into adequate structural blocking.

Floating shelves include WingIts® fasteners for easy and durable installation into hollow walls.

Installs in minutes, scratch resistant surface lasts a lifetime and is maintenance-free.



WESBFS Floating Shelf



WTBSCKLPS Towel Bar and Floating Shelf Combo



WCFSEF Floating "C" Shelf with Extended Fascia



MAW35 MASTER Anchor™ Fastener

**THE WORLD'S STRONGEST FASTENER®**  
Available for all WingIts® products for quick and easy installation



C-Shelf installed with our included WINGITS® MASTER Anchor™ fasteners



# SPECIALTY PRODUCTS

The WingIts® specialization in customization sets the industry standard.

Our ability to deliver customized products, with the same strength and durability for which WingIts® is known, is what sets us apart and keeps designers coming back to us again and again.



WPAC18PSFG  
2-Tier Portable Amenities Cart



MAX Elegance™  
WXEHBWCS  
Wall Valet Hook Bar  
"Casual"



MAX Elegance™  
WXEHBWKK  
Wall Valet Hook Bar  
"Confident"



WACARH  
Angled Robe Hook



WRITB2RH  
MODERN Elegance™  
Accessory Panel

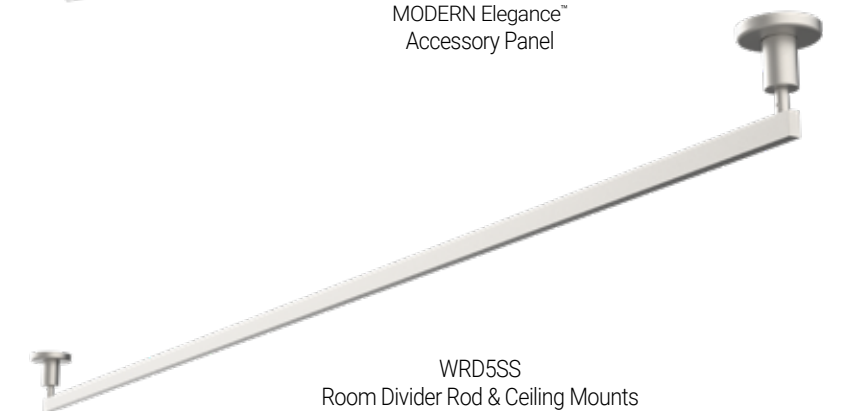

WRD5SS  
Room Divider Rod & Ceiling Mounts

# GBW40 THE WORLD'S STRONGEST

The GBW40 is rated up to 800 lbs. in drywall with tile, exceeds ADA criteria, and meets all building codes.

WingIts® fasteners install in minutes and last a lifetime.

Water-resistant and fire-resistant.

The GBW40 or The BEAST™, has been specified by every major hotel chain in North America over the last 20 years.



GBW40  
The BEAST™

**OVER 3 MILLION  
INSTALLATIONS  
WITHOUT A  
SINGLE FAILURE**



Drills holes through ceramic wall tile in seconds.

Industrial grade carbide cutting tool designed for ceramic, marble, plaster, steel, glass and lath.



Available separately  
or in 3 or 5 drill bit sets

# THE WORLD'S STRONGEST FASTENER®



**GBWME40**  
Designer Grab Bar Fastener

Rated up to 600 lbs. when used to install WingIts® grab bars in drywall with tile.  
Handles vector and vibratory forces.  
Guaranteed to NEVER loosen.  
Water-resistant and fire-retardant.  
Used to install WingIts® Grab Bars for MODERN Elegance™, MODERN Transitional™, INFINITE Elegance™, INFINITE Transitional™, INFINITE Squared™, and more...



**MAW35**  
MASTER Anchor™

WINGITS® MASTER Anchors™ are included with all WINGITS® towel racks, shelves, shower baskets, foot rests, and lighted mirrors.  
Rated up to 300 lbs. (in shear).  
Handles vector and vibratory forces.  
Guaranteed to NEVER loosen.  
Water-resistant and fire-retardant.  
Thousands of uses: bath accessories, window dressing, typical shelving, dispensers, most wall mount accessories.

**+ MANY MORE fasteners from WINGITS®...**



**RESGBW35**  
Structurally Engineered  
Grab Bar Fastener



**MAWSD35**  
MASTER Anchor™  
Super Duty Fastener



**MAWHP35**  
MASTER Anchor™ Fastener  
with Hook Plate



# WINGITS®

## Installation flexibility

Install anywhere in the wall with WingIts® World's Strongest Fastener® systems

## Solid 18/8 (304) stainless steel

Engineered to last a lifetime

## Maintenance-free

No parts that loosen over time  
No lines or joints to clean

## Easy waterproof installation

No caulking required

## Faster installation

Lower labor costs

## WINGITS®

### BRIDGEBIND™ TECHNOLOGY

WingIts® standoffs are solid stainless steel HeliArc® welded using BridgeBind™ Technology to create the ultimate structural bond.

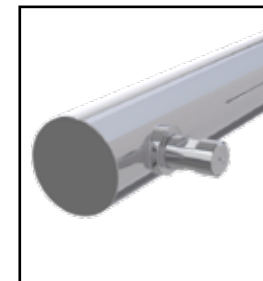

### WORLD'S STRONGEST FASTENERS®

Install anywhere with WingIts® World's Strongest Fastener® systems.



### TRI-LINEAR BUFF TECHNOLOGY™

Tri-Linear Buff Technology™ polishes 18/8 (304) stainless steel to a brilliant mirror finish.



## EVERYONE ELSE

### HOLLOW TUBING

Chrome plated hollow tubes are structurally and aesthetically inferior.



### ZINC MOUNTING BRACKETS

Zinc mounting brackets, made from inferior materials with no structural bond to the product, must be installed into structural blocking.



### CHROME PLATING

Chrome plating is toxic to the environment and plated stainless steel is subject to rust, chip, and pit over time.



...GUARANTEED FOR A LIFETIME

# WINGITS®

**CONTACT**  
866.990.0235  
sales@wingits.com

**SAL SISTO**  
INNOVATOR  
sal@wingits.com  
O: 877.894.6448 | M: 908.875.4297

**DAVID BURCON**  
VP, SALES & PRINCIPAL  
dburcon@wingits.com  
O: 866.990.0235 | M: 734.330.4662

**BILLY MAC**  
NATIONAL HOSPITALITY  
BRAND MANAGER  
billymac@wingits.com  
O: 540.692.1102 | M: 540.335.5264

**BEN RAPP**  
DIRECTOR OF NATIONAL SALES  
ben@wingits.com  
O: 866.990.0235 | M: 248.914.2490



Printed on  
Recycled Paper 