

JACK & JUNE

Rectangle Picnic Table
JJ-PIC-REC-RW

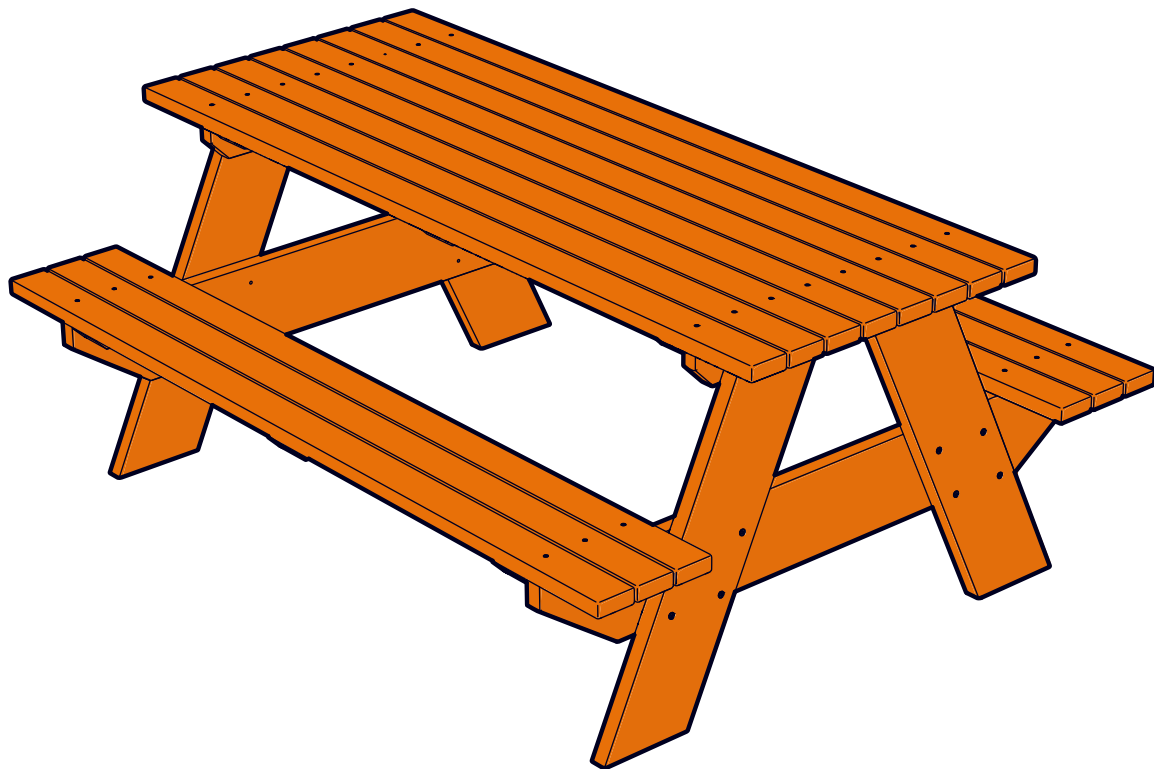

2L-7991-00

PRE-ASSEMBLY TIPS

1. **Read this manual carefully before starting assembly.** Read each step completely before beginning each step.
2. **Some smaller parts may be shipped inside larger parts. Check inside all parts and cartons before assembling or ordering parts.**
3. **To make assembly easier, use the Hardware Identifier on page 4 to identify and sort all parts. Check all cartons for kits. All hardware may not be located in one kit.**
4. **Do not tighten until instructed to do so. If parts are tightened too soon, parts may not easily fit together. Leave nuts slightly loose until you are instructed to tighten them.**
6. **Save these instructions and your proof of purchase (receipt) in the event that the manufacturer has to be contacted for replacement parts.**

ESCALADE®
S P O R T S

Please Do Not Return This Product To The Store!

Contact Escalade® Sports customer service department at:

Phone: 1-800-GO-SWING Toll – Free !

Escalade Sports

Physical Location:

817 Maxwell Ave.
 Evansville, IN 47711

Mailing Address: (Correspondence Only)

PO Box 889
 Evansville, IN 47706

Please visit our Website at:
www.escaladesports.com

ON-LINE TROUBLE SHOOTING TECHNICAL ASSISTANCE
 ON-LINE PARTS REQUESTS FREQUENTLY ASKED QUESTIONS
 ADDITIONAL ESCALADE®SPORTS PRODUCT INFORMATION



PARTS LIST (NOT ACTUAL SIZE)

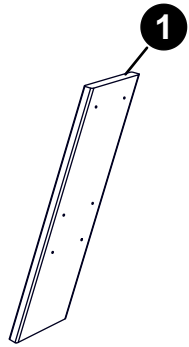

2x8 Leg
PG-28-0006
QTY. 4

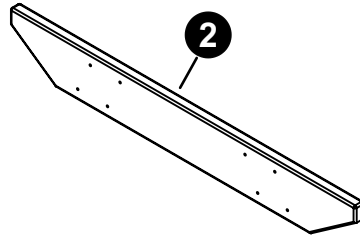

2x8 Bottom Support
PG-28-0007
QTY. 2

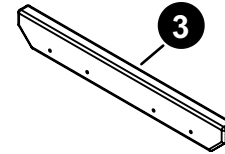

2x4 Rec Table Cross Support
PG-24-0098
QTY. 2

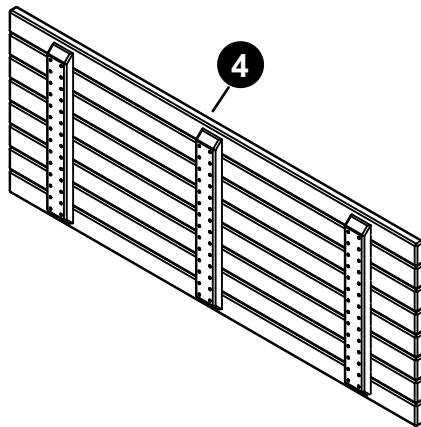

Rec Picnic Table Top
JJ-PIC-REC-TOP-RW
QTY. 1

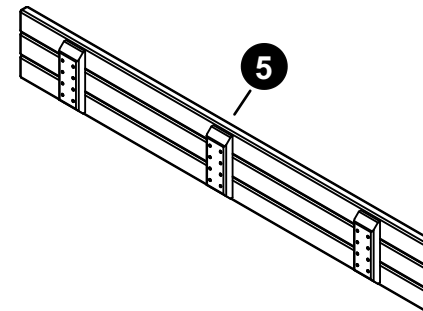

Seat Assembly
JJ-PIC-REC-SEAT-RW
QTY. 2

HARDWARE IDENTIFIER (ACTUAL SIZE)

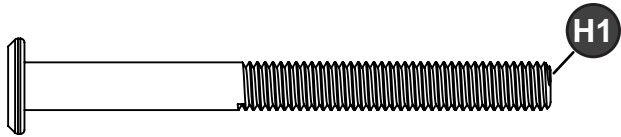

Allen Bolt M6X70mm
QTY. **24**

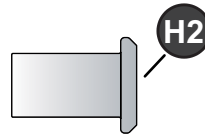

M6X15mm NUT
QTY. **24**

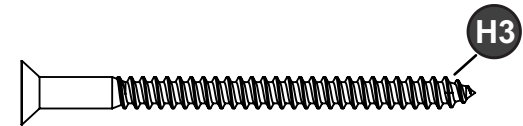

M4 X 60MM Phillips Flat Head Screw
QTY. **28**

TOOLS NEEDED



ALLEN KEY (Included)
QTY. **2**



PHILLIPS SCREW DRIVER
(NOT INCLUDED)

NOTE:

An electric screwdriver is helpful in assembly. However, please set at low torque and use extreme caution with an electric screwdriver because you could over-tighten the hardware & strip out the screws.

STEP 1

Attach Bottom Support (#2) to Legs (#1) with Allen Bolts (H1) and Allen Nuts (H2). Tighten until the frame is stable but **do not** tighten completely yet.

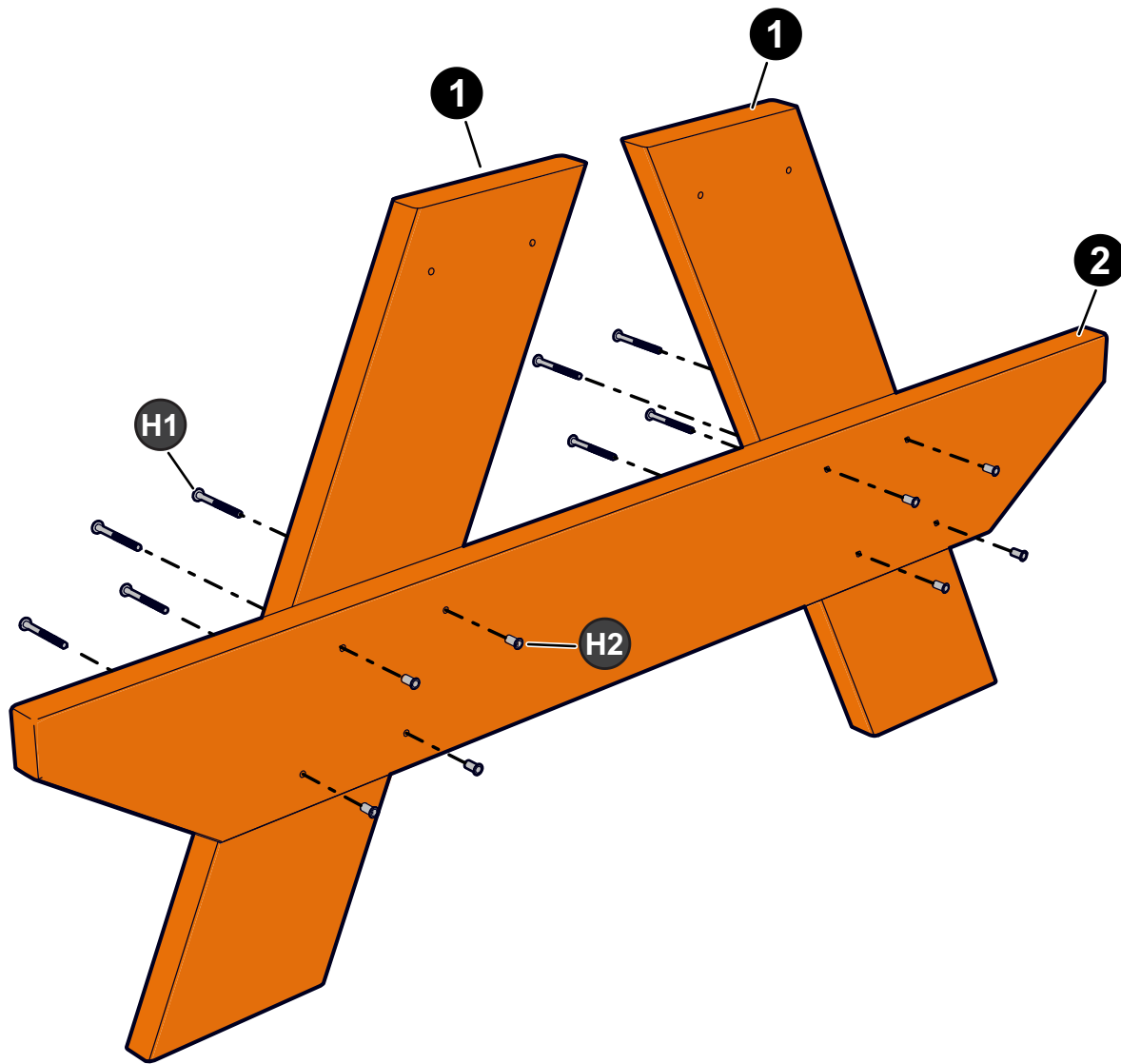

STEP 2

Attach Cross Support (#3) to Legs (#1) with Allen Bolts (H1) and Allen Nuts (H2).

NOTE: Tighten until the Leg Assembly frame is stable but **do not** tighten completely yet.

STEP 3

Repeat **Step 1&2** to make a second Leg Assembly.

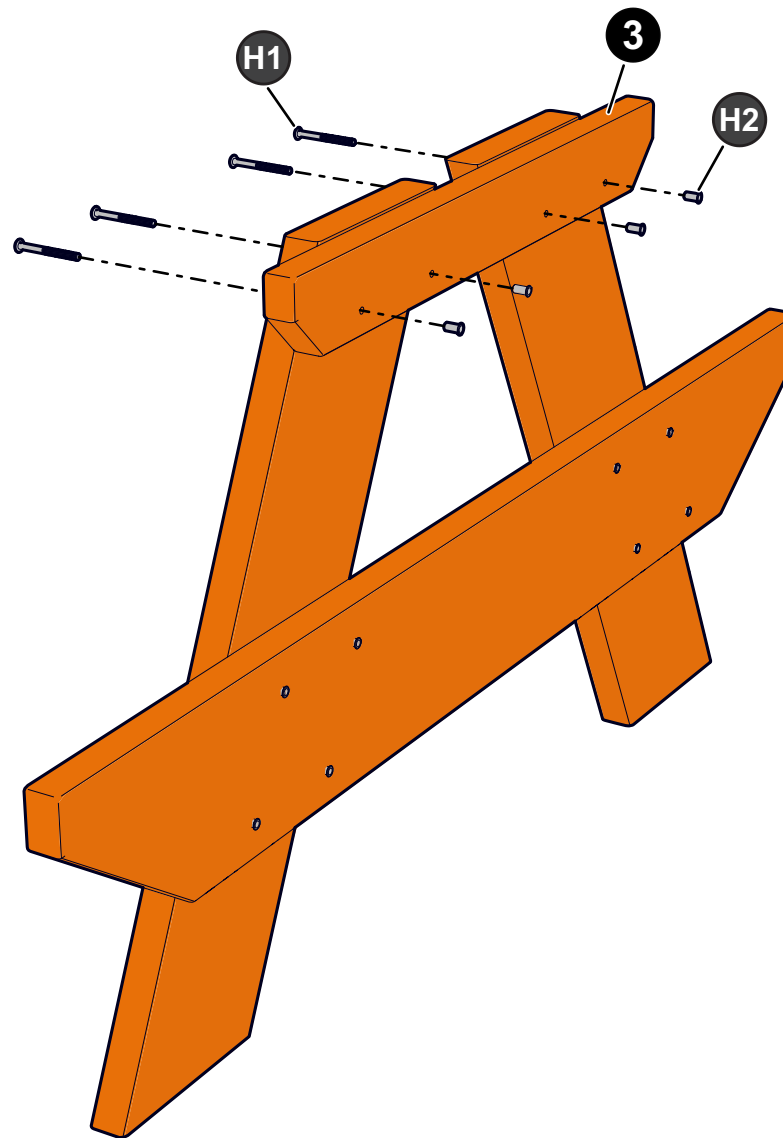

STEP 4

With the help of at least another adult stand up the leg assemblies and place the Table Top (#4) and Seats (#5) as shown.

NOTE: Before attaching H3 screws make sure to **butt up** the Seat supports and Table top supports against the inside of the **Cross/Bottom Supports** on the Leg assembly frame. See **Detail A**.

STEP 5

On both ends of the table line up Table Top (#4) and Seats (#5) and drive one screw into the center hole of the **seats** and on the end holes of the **Table Top** so the frame stable. See **Detail A**.

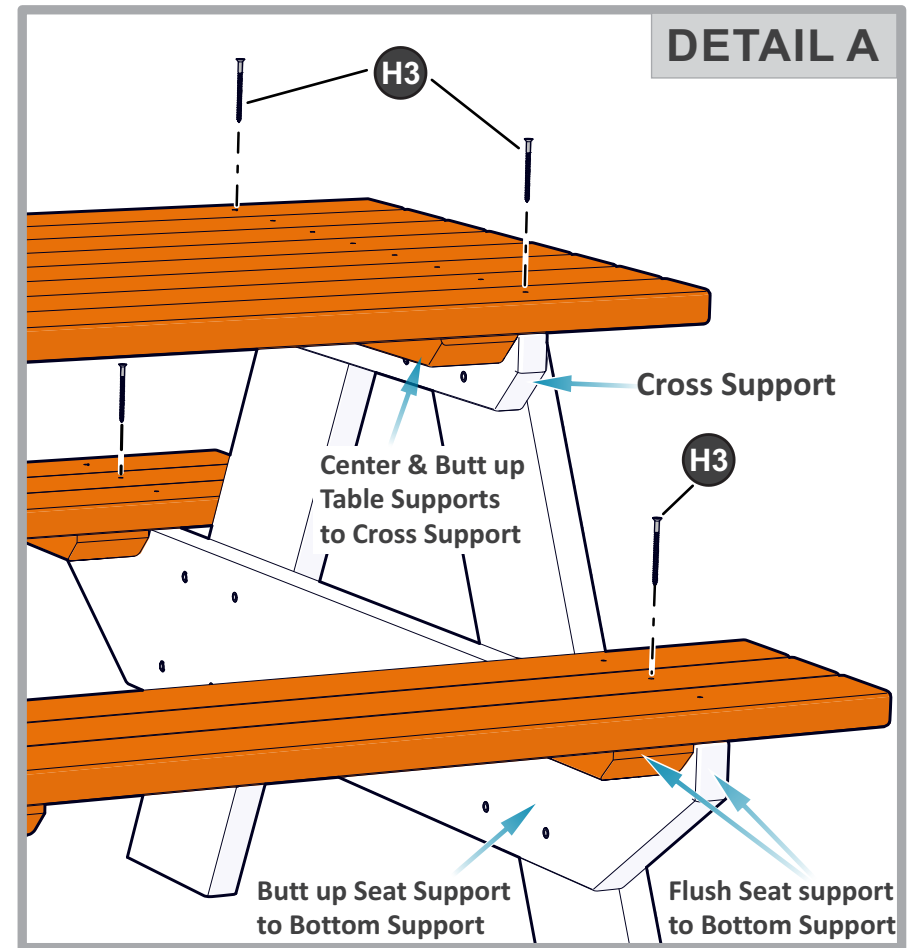
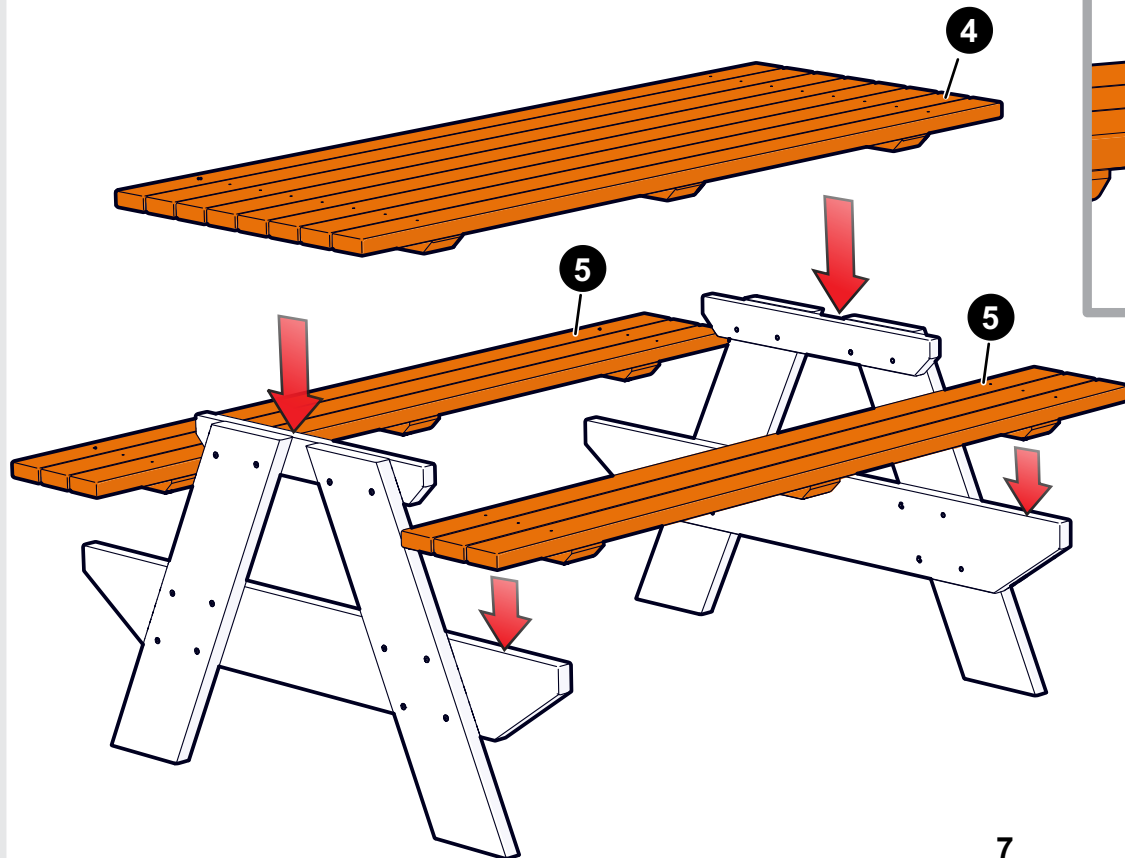

STEP 6

Continue to drive Screws (H3) until the Table Top (#4) Seats (#5) are secure.

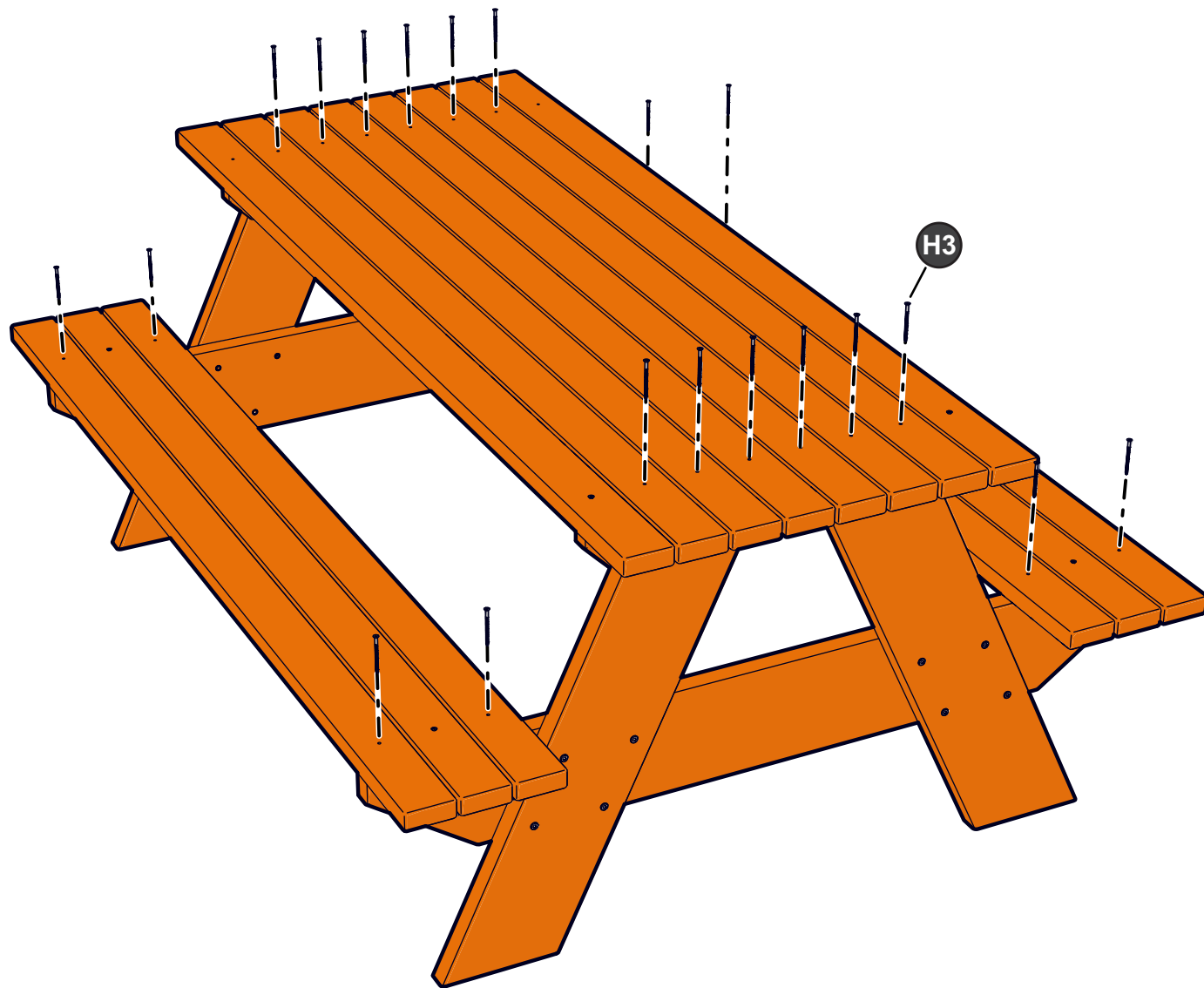

STEP 7

Tighten all Allen hardware with the Allen Wrenches provided until parts are secure.

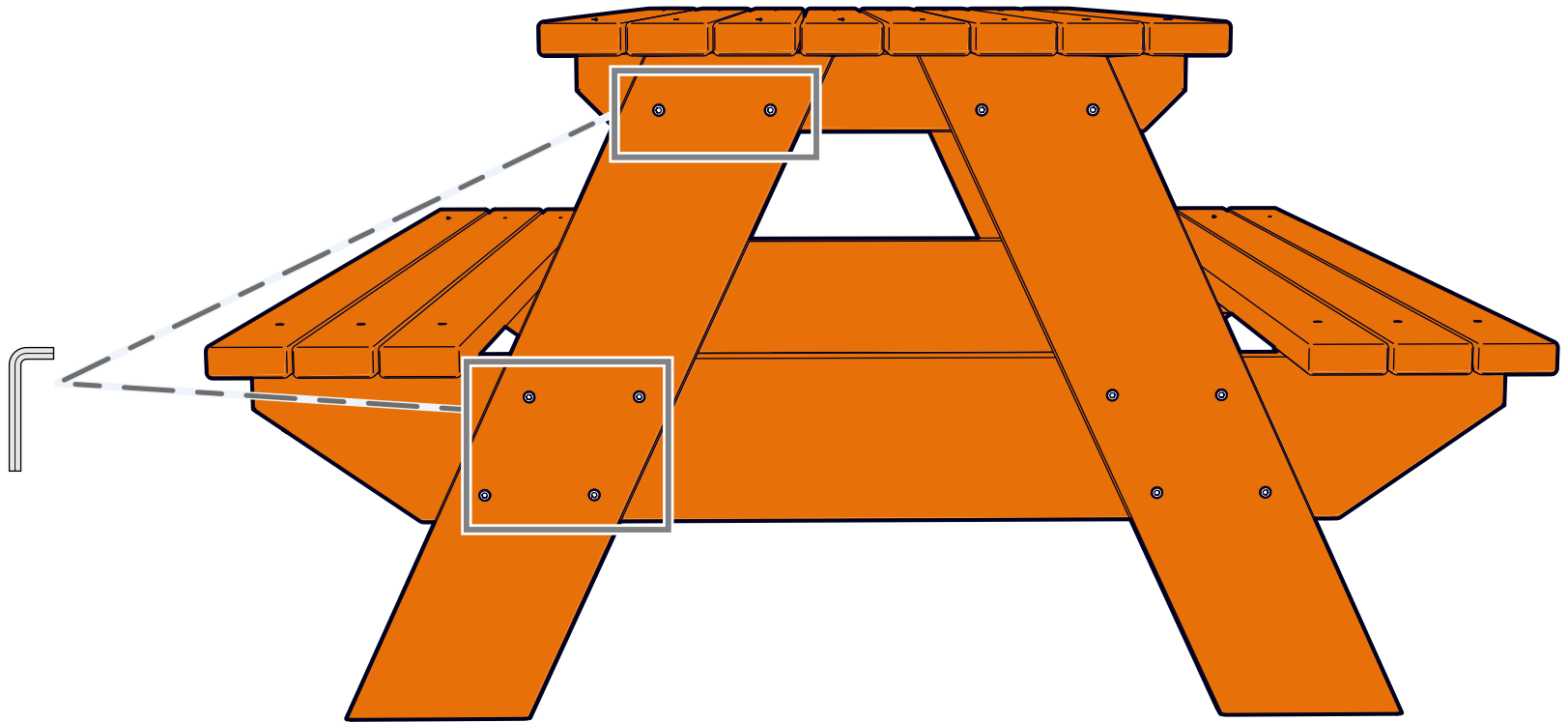

JACK & JUNE WARRANTY

1 Year Warranty

Subject to proper installation and normal residential use, Jack & June warrants, subject to the limitations stated below, to the original retail purchaser, parts to be free from defects in material and workmanship for a period of **one year** from date of purchase. Merchandise covered under this limited **one-year** warranty will, at our option, be repaired or replaced, excluding any freight or labor fees.

For **one Year** after the original purchase date of our **products**, Jack & June warrants, to the original retail purchaser, all wooden components against structural failure due to corrosion, wood rot, or insect infestation. Seasonal checks, surface cracks, knotholes and knots, not resulting in structural failure, are natural characteristics of all wooden play equipment, are not covered under this warranty and will not affect the integrity of your playset.

Jack & June warrants to the original retail customer that we will replace any hardware that fail due to rust or breakage (excludes surface rust).

Timber is a natural material which can absorb and release moisture. Although this product is designed to minimize this effect, in certain circumstances some movement or distortion is unavoidable. During dry hot weather timber may shrink and check - this is a normal process of weathering. After the first year of service it is advisable to clean and apply a non-toxic stain or sealant to the wood, safe for children's use.

Components covered under this **1 year** warranty will be replaced free of charge excluding freight and labor fees.

Non-residential use of the playset is prohibited and voids the warranty as the playsets are designed for residential use only.

Escalade Sports reserves the right to examine photographs and/or physical evidence of merchandise claimed to be defective, and to recover said merchandise, prior to disposition of warranty claims. Merchandise returned to our factory for examination or recovery must be shipped freight prepaid, unless a Return Authorization Number is issued.

This warranty program does not cover normal wear and tear, color fading, or damages resulting from misuse, abuse, vandalism, alteration, acts of God, or assembly and maintenance contrary to our instructions. Escalade Sports assumes no responsibility for incidental or consequential damages which may arise from the purchase or use of our equipment. Please supervise your children's play activity and maintain your play equipment periodically.

This warranty is expressly in lieu of all other warranties, expressed or implied, including warranties of merchantability or fitness for use. Jack & June does not assume or authorize any person to assume for us, any other liability in connection with the sale of our products.

Special Note: Jack & June reserves the right to make changes in materials, design, and pricing without notice. See your instruction manual for maintenance requirements. Your child's safety is your responsibility; therefore, you should inspect this equipment regularly for wear and safety.

For warranty service, contact:

Escalade Sports

P.O. Box 889

Evansville, IN 47706

1-800-GO-SWING

Or E-Mail us at: playgroundcs@escaladesports.com