

Z100 15" [381 mm] DIAMETER MAIN ROOF DRAIN Low Silhouette Dome

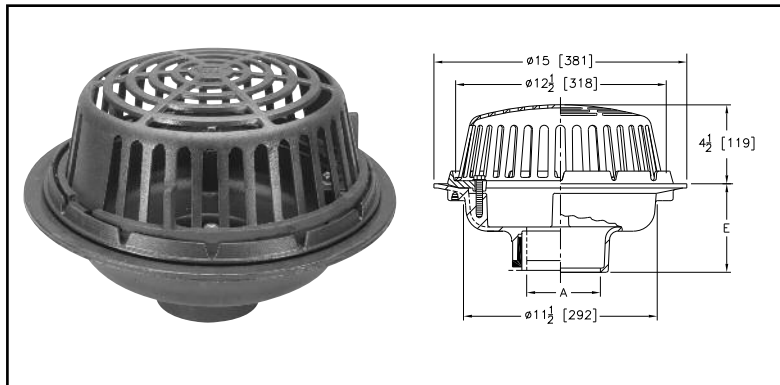

A Pipe Size Inches [mm]	Approx. Wt. Lbs. [Kg]	Dome Open Area Sq. In. [cm ²]
2 - 3 - 4 [51-76-102]	26 [12]	103 [664]
5 - 6 [127-152]	27 [12]	
8 [203]	28 [13]	

ENGINEERING SPECIFICATION: ZURN Z100 15" [381 mm] diameter roof drain, Dura-Coated cast iron body with combination membrane flashing clamp/gravel guard and low silhouette Poly-Dome.

OPTIONS

OUTLETS (Specify pipe size in inches and type of outlet.)

OUTLET TYPE	OUTLET DESIGNATION Pipe Size/Outlet Type	'E' BODY HT. DIM. In./[mm]
Inside Caulk	2IC, 3IC, 4IC, 5IC, 6IC, 8IC	5-1/4" [133 mm]
Threaded	2IP, 3IP, 4IP, 5IP, 6IP, 8IP	3-3/4" [95 mm]
No-Hub	2NH, 3NH, 4NH, 5NH, 6NH, 8NH	5-1/4" [133 mm]
Neo-Loc	2NL, 3NL, 4NL	4-5/8" [118 mm]

PREFIXES

Z	D.C.C.I. Body with Poly-Dome*
ZA	D.C.C.I. Body with 6-3/4" [171 mm] High Aluminum Dome
ZC	D.C.C.I. Body with Cast Iron Dome
ZRB	D.C.C.I. Body with Plain Bronze Dome

SUFFIXES

- AC Angular Underdeck Clamp
- AR Acid Resistant Epoxy Coated Finish
- AW 3/4" [19 mm] to 4" [102 mm] Adjustable Water Level Regulator (Specify Height) (ZC Only)
- BS Bronze Mesh Screen Over Dome
- C Underdeck Clamp
- DP Top-Set® Roof Deck Plate (Replaces both the -C and -R)
- DR Adjustable Drain Riser Extension Assembly
Adjustment from 3-5/8" [92 mm] to 7-1/4" [184 mm]
- DX Dex-O-Tex Flange
- E Static Extension 1" [25 mm] thru 4" [102 mm] (Specify Height)
- EA Adjustable Extension Assembly 1-3/4" [45 mm] thru 3-1/2" [89 mm]
For E and EA Extensions Greater Than 4" [102 mm] (Specify Height)
- ES Static Extension with Secondary Clamp Collar at Body
(For clamping at roof drain body.)
- FG Flush Grate (Replaces Dome Strainer)
- G Galvanized Cast Iron
- GD Galvanized Cast Iron Dome (ZC Only)
- HD 6-3/4" [171 mm] High Aluminum Dome Strainer
(148 sq. in. [955 cm²] open area)
- R Roof Sump Receiver
- SC Secondary Clamp Collar
- SS Stainless Mesh Screen Over Dome
- TC Neo-Loc Test Cap Gasket (2" [51 mm] to 4" [102 mm] NL Bottom Outlet Only)
- VP Vandal-Proof Secured Top
- W2 2" [51 mm] Internal Water Dam
- W3 3" [76 mm] Internal Water Dam
- W4 4" [102 mm] Internal Water Dam
- XJ Vertical Expansion Joint (See Z190)
- 84 Stainless Steel Perforated Gravel Guard (Specify Height)
- 85 Stainless Steel Perforated Extension (Specify Height)
- 89 2" [51 mm] High External Water Dam
- 90 90° Threaded Side Outlet Body (2" [51 mm] thru 6" [152 mm])

*Regularly furnished unless otherwise specified.