



Project Name: \_\_\_\_\_

Location: \_\_\_\_\_

Item #: \_\_\_\_\_

Qty: \_\_\_\_\_

## Adcraft Electric Deep Fryer, 10 lb Capacity, in Stainless Steel

### DF6LS



Engineered for precision and reliability, the Adcraft Deep Fryer is an asset to any commercial kitchen. Crafted from durable SUS430 and SUS304 stainless steel, it ensures longevity and robust performance, making it ideal for bustling foodservice environments. The high-grade materials provide a sleek, professional appearance and facilitate easy cleaning and maintenance. The fryer features advanced thermostatic control, allowing for precise temperature management between 160° and 370°F, ensuring consistent cooking results. It has a capacity of 10 pounds for oil.

### Features and Construction

- Constructed from SUS430 and SUS304 stainless steel for durability
- Operates on 120V with a NEMA 5-15P plug type
- Designed without burners for a streamlined operation
- Offers a 10 lb capacity of oil for efficient frying
- Equipped with sturdy legs for stable placement
- Designed for electric use, enhancing energy efficiency
- Manual ignition with thermostatic control for precision
- Temperature range from 160° to 370°F
- Dimensions are 16.09" x 12.13" x 11.16"
- Covered by the Adcraft One-Year Limited Warranty

### Electric

120V / 1750W / 14.5A  
Cord Length (Inches): 59"  
Plug Type: NEMA 5-15P  
Cord set included

NEMA 5-15P



### 3rd Party Approvals



### Warranty (USA / Canada)

Protected by Admiral Craft Equipment Corporation's one-year limited warranty.

Contact Admiral Craft Equipment for details at 1-877-672-7740



### Included Components

Cover, Fryer Basket, Tank

### Capacity

Pounds: 10 lbs. of oil

### Temperature

Temperature Range (Fahrenheit): 160° - 370°



# Adcraft Electric Deep Fryer, 10 lb Capacity, in Stainless Steel

DF6LS

FRONT

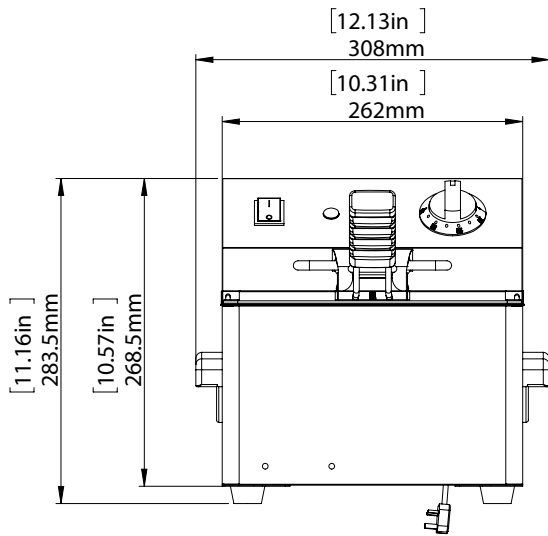

SIDE

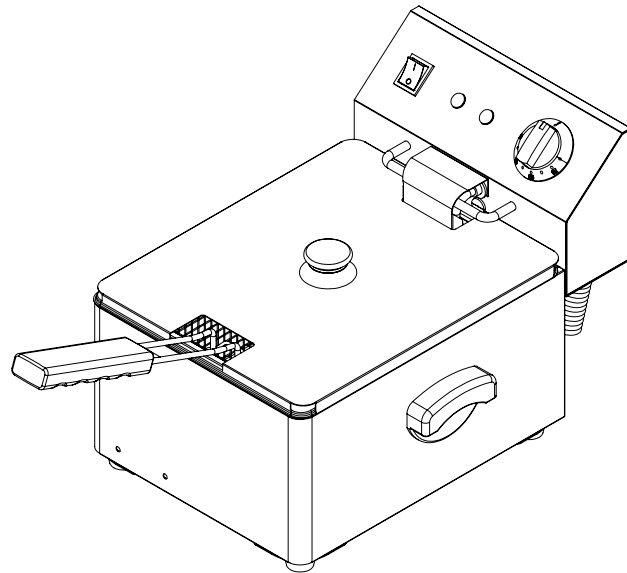
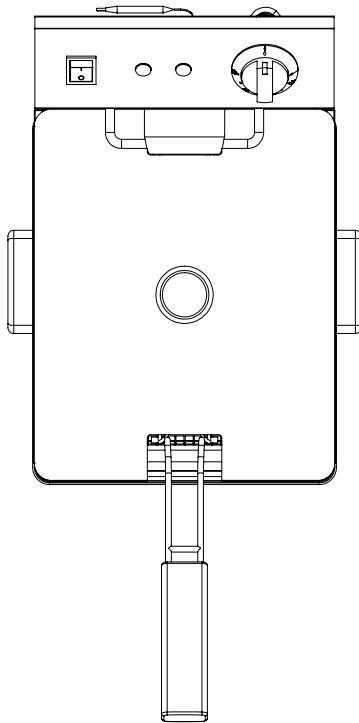
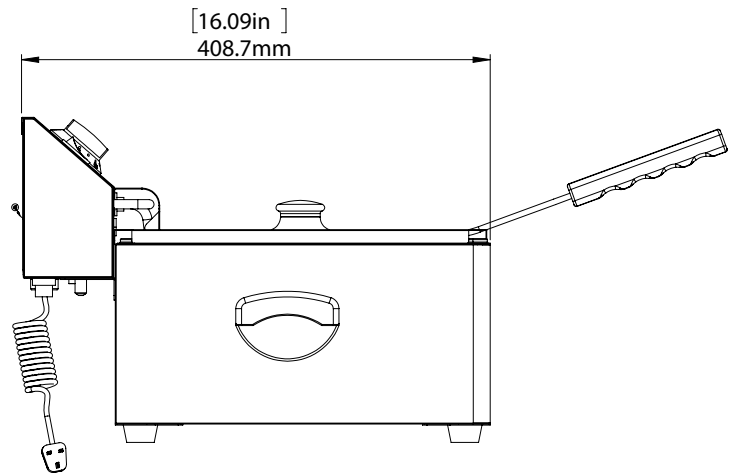

TOP

## Electric

Control Type	Oil Capacity (lbs)	Volume Capacity	Assembled Dimensions L x W x H (in)	Package Dimensions L x W x H (in)	Item Weight (lb)	Shipping Weight (lb)
Thermostatic	10 lbs. of oil	6L of oil	16.09" x 12.13" x 11.16"	18.00" x 12.40" x 13.00"	5.0	6.0

Due to periodic changes in designs, methods, procedures, policies and regulations, the specifications contained in this document are subject to change without notice. While we exercise good faith efforts to provide information that is accurate, we are not responsible for errors or omissions in information provided or conclusions reached as a result of using the specifications. By using the information provided, the user assumes all risks in connection with such use.