

FLEXSTEEL®

W1077-835

Friendship Table

IMPORTANT NOTE

Carefully remove all the parts from the carton and put them individually on a soft cloth to prevent damage to the parts.

We have taken great care in the design of this product and request that you carefully and strictly follow our assembly instructions to ensure a completed product as it was designed.

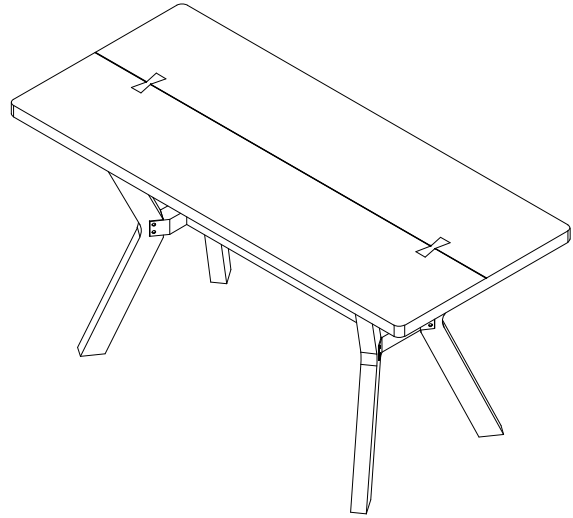

Part List

Assembly Instructions 1/3

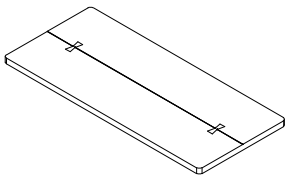

A. Table Top
1 piece



B. Table Leg
4 pieces



C. Connecting Panel
2 pieces

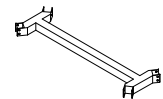

D. Metal Bar
1 piece

Hardware List



1.Flat Washer
 $\Phi 5/16 \times 19 \times 1.5\text{mm}$
44 pieces



2.Spring Washer
 $\Phi 5/16 \text{''}$
44 pieces



3.Long Bolt
 $\Phi 5/16 \text{''} - 18 \text{ UNC} \times 32\text{mm}$
28 pieces



4.Short Bolt
 $\Phi 5/16 \text{''} - 18 \text{ UNC} \times 20\text{mm}$
16 pieces

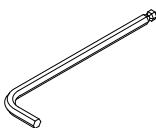

5.Hex Key
 $110 \times 25 \times 4\text{mm}$
1 piece

Tool(s) recommended for assembly: Level

IMPORTANT NOTES

- Do not tighten up all the bolts until each part is properly assembled.
- Keep the Hex Key in a safe place as you may need to tighten up the bolts in the future.
- Use a soft cloth between these parts and the floor.
- We recommend this product be assembled by at least two adults.

STEP 1

Attach Table Leg (B) to Metal Bar (D) by 4 Short Bolt (4), 4 Spring Washer (2) and 4 Flat Washer (1) loosely, repeat this step on each leg, level all legs then fully tighten with Hex Key (5). (See Figure 1.)

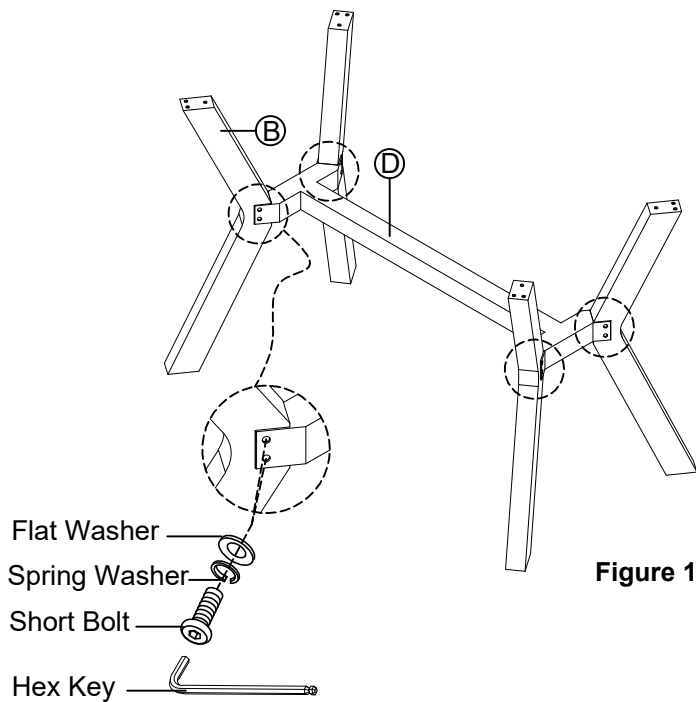

Figure 1

STEP 2

Assemble Connecting Panel (C) to Table Leg (B) with 6 Long Bolts (3), 6 Spring Washer (2) and 6 Flat Washer (1), fully tighten with Hex Key (5). Repeat this step on the other side. (See Figure 2.)

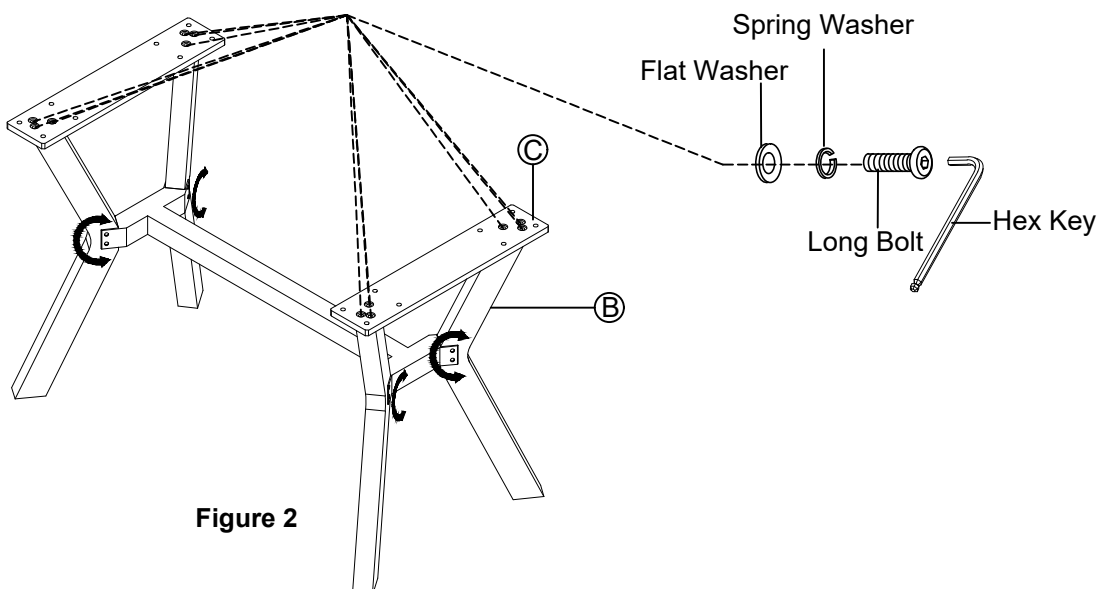

Figure 2

STEP 3

Attach Connecting Panel (C) to Table Top (A) by 16 Long Bolt (3), 16 Spring Washer (2) and 16 Flat Washer (1), fully tighten with Hex Key (5). (See Figure 3.)

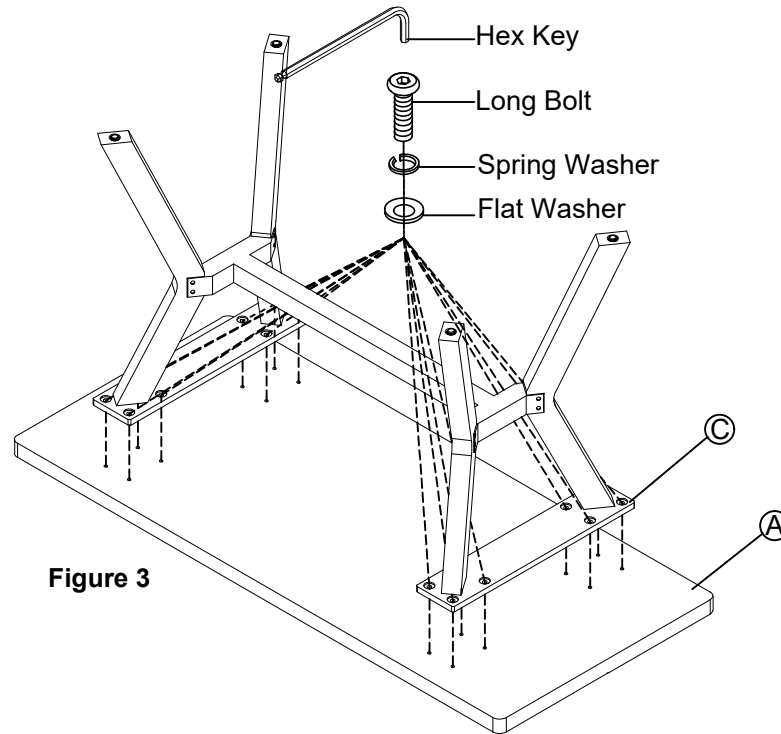

Figure 3

STEP 4

Flip Table over and adjust the levelers on the legs until the furniture is leveled. (See Figure 4.)

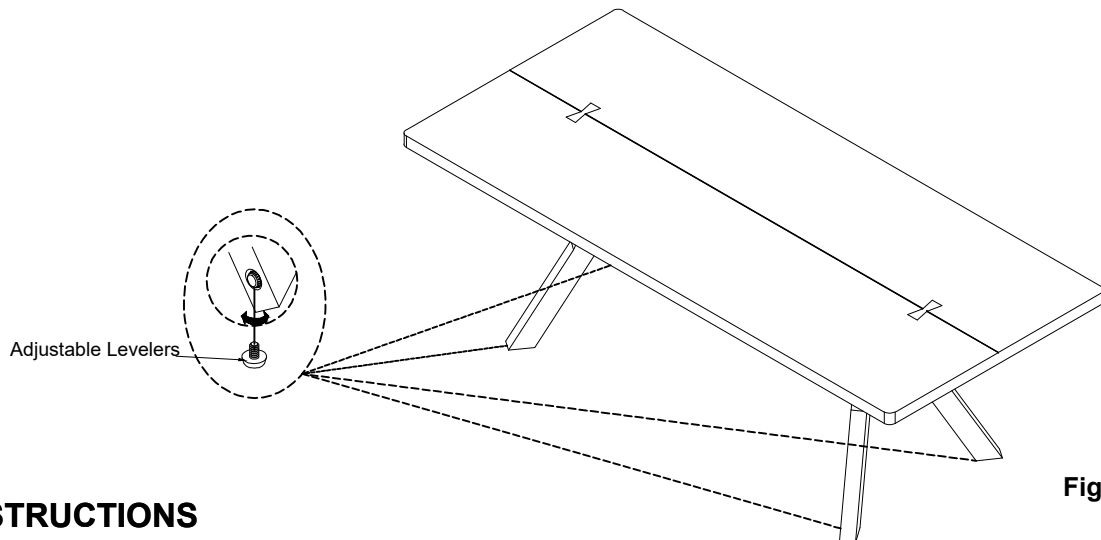

Figure 4

CARE INSTRUCTIONS

- To avoid scratches, do not place sharp or jagged objects directly on the table top.
- Do not place hot items directly on the tabletop.
- Use placemats or trivets under hot items and coasters under beverages to prevent marks and stains.
- Avoid the use of harsh chemicals or abrasive cleaning materials.
- Wipe the table clean with a soft, dry cloth after each use.
- Wipe up spills quickly with a soft, dry cloth.

Flexsteel Industries, Inc.

For Parts or Customer Service call toll-free: 1-888-415-3979

Monday-Friday, 8:00-5:00pm Central Time

Email: customersolutions@flexsteel.com

www.flexsteel.com