

SIDES	BOTTOM
4 1/2" KNOCKOUTS	2 1/2" KNOCKOUTS
6 1/2"-3/4" MOON KNOCKOUTS	2 3/4" KNOCKOUTS
	1 Groud Hump
2 PCS #6-20×1-7/8 Tapping Screws Installed	
Material:Steel-0.0625"-G60 Galvanized	

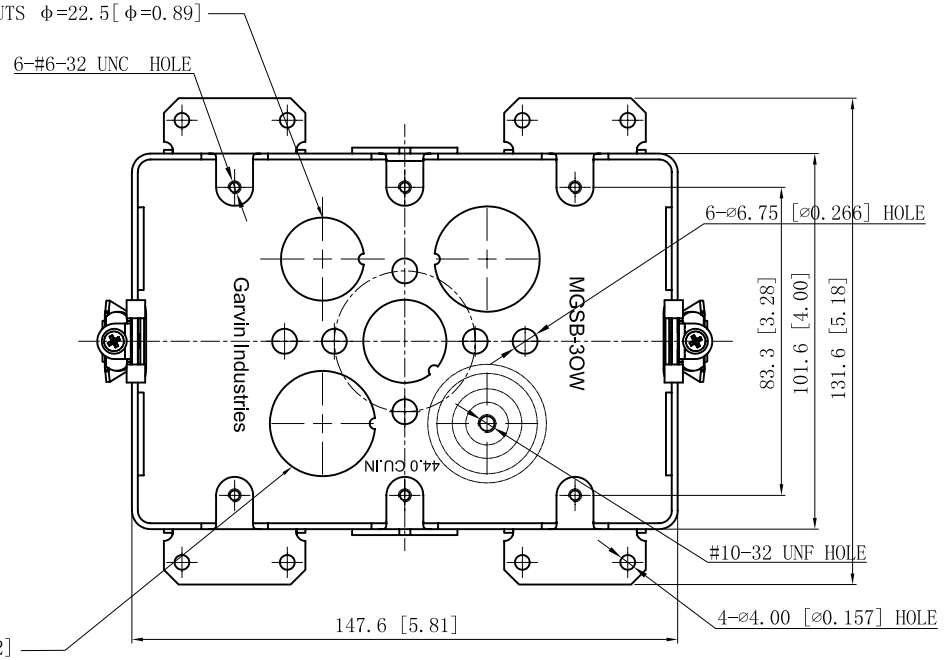
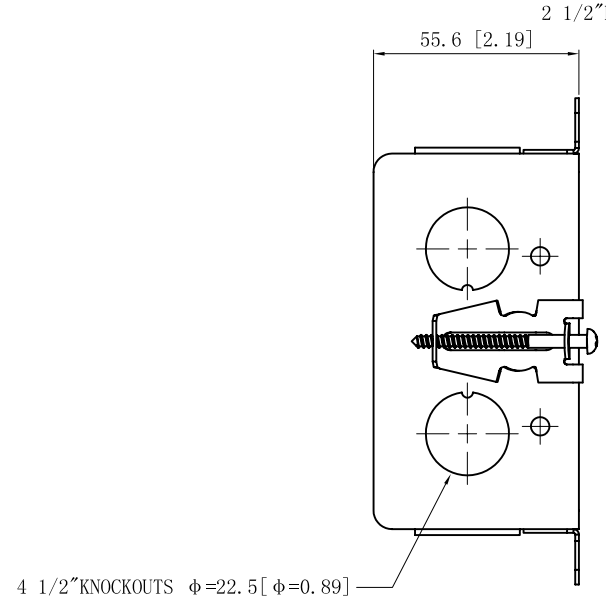
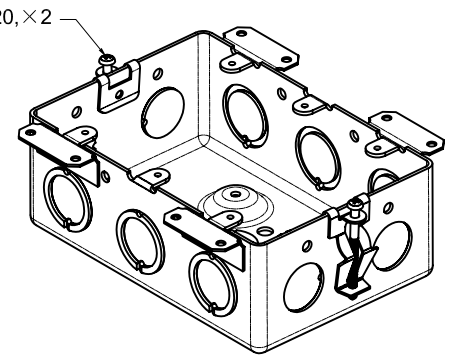
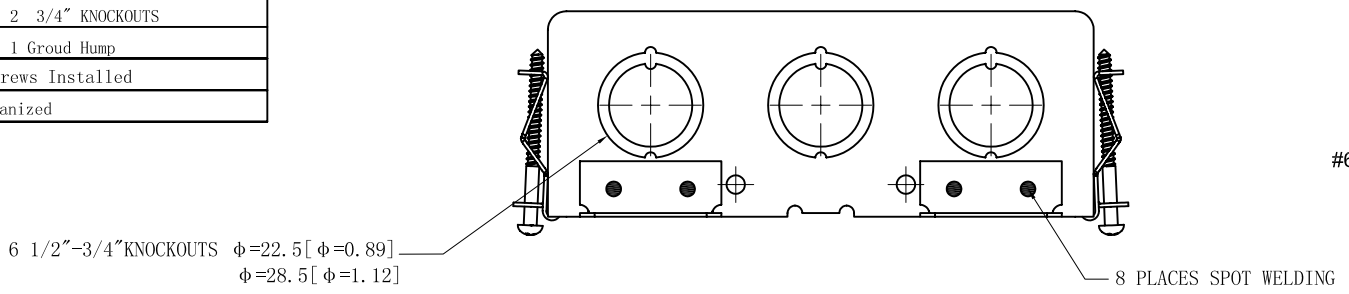

DESCRIPTION
TRADE REFERENCE TERMS

This data sheet is for reference only .GARVIN INDUSTRIES reserves the right to make changes to the design without prior notice.

STANDARD PACKING	TITLE		
	3-GANG SWITCH BOX 2-1/8" DEEP		
25 PCS	SIZE	DWG NO.	REV
	A4	MGSB-30W	A
DATA SHEET			